

Chapter 86

ACTUATOR, ENGLISH ELECTRIC, TYPE AE4009, Mk. 5

LIST OF CONTENTS

	<i>Para.</i>		<i>Para.</i>
<i>Introduction</i>	1	Installation	24
Description		Servicing	25
<i>Drive motor</i>	2	<i>General</i>	26
<i>Gearbox</i>	7	<i>Brushgear</i>	27
<i>Clutch magnet assembly</i>	10	<i>Commutator</i>	31
<i>Limit switch box</i>	15	<i>Bearings</i>	33
<i>Housings</i>	17	Testing	
Operation	18	<i>Functional test</i>	35
		<i>Insulation resistance test</i>	36

LIST OF ILLUSTRATIONS

	<i>Fig.</i>		<i>Fig.</i>
<i>General view of actuator</i>	1	<i>Section of actuator</i>	3
<i>Section of motor</i>	2	<i>Wiring diagram</i>	4

LEADING PARTICULARS

<i>Actuator, Type AE4009, Mk. 5</i>	<i>Ref. No.</i>
<i>Nominal voltage</i>	28V d.c.
<i>Rating</i>	1 minute
<i>Stroke</i>	1.8 in.
<i>Maximum load</i>	250 lb
<i>Reversing load</i>	100 lb
<i>Clutch slip load</i>	Not less than 250 lb
<i>Time of extend stroke</i>	2.5 sec.
<i>Time of retract stroke (max.)</i>	4 sec.
<i>Rotation of motor, looking on drive end</i>	Clockwise
<i>Brush grade</i>	HAM. EGO.
<i>Minimum brush length</i>	0.175 in
<i>Brush spring pressure</i>	4 to 5 oz
<i>Minimum commutator diameter</i>	0.595 in
<i>Weight</i>	4 lb

RESTRICTED

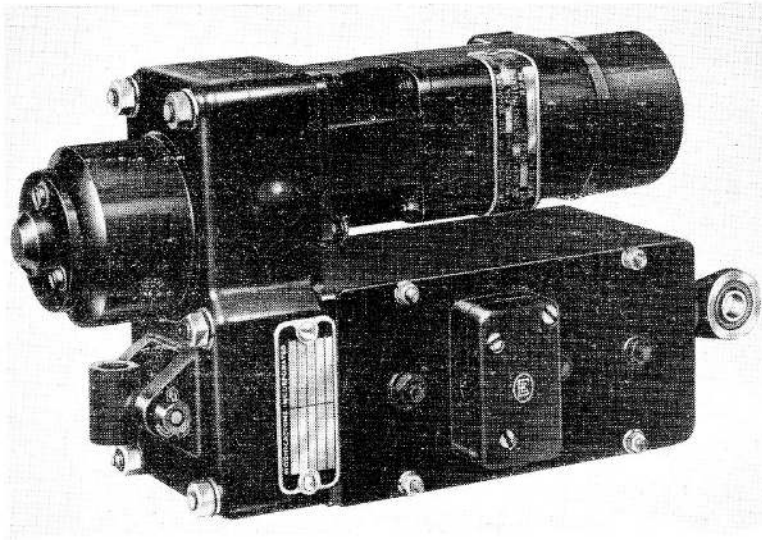

Fig. 1. General view of actuator

Introduction

1. The Type AE4009, Mk. 5 linear actuator consists of a unidirectional d.c. drive motor, a reduction gear box, a magnetic clutch and a reciprocating ram. Its chief application is to provide rudder lock control on aircraft under all flight conditions.

DESCRIPTION

Drive Motor

2. The motor is a 2-pole, series wound machine running at 11000 rev/min in a clockwise direction looking on the drive end. It consists of three main assemblies: armature and shaft, field and frame, and magnetic brake.

3. The armature is mush wound and its shaft is supported at either end in ball bearings. A brake drum is fitted to the shaft towards the drive end.

4. The field coils are housed in a laminated magnet yoke and pole assembly secured inside the motor frame. The yoke and poles are manufactured from the same stampings and are therefore of integral construction.

5. The brake consists of a toroidal yoke and coil assembly fitted with four lined brake shoes equally spaced around the yoke periphery. This assembly fits over the armature shaft inside the brake drum so that the brake shoes press against the inside of the brake drum when no current flows through the brake coil. Pressure on the shoes is maintained by small springs fitted between the brake yoke and the shoes.

6. The motor brushgear is secured to the tail end of the frame and consists of two brush boxes mounted on a moulded bakelite rocker ring. The brush boxes are each fitted with a coil spring to maintain brush pressure on the commutator surface.

Gearbox

7. The gearbox is fixed to the drive end of the motor and houses a reduction gear train and clutch mechanism which provides the drive from the motor to the ram.

8. The gear train consists of a splined clutch gear which meshes with the motor pinion, and a gear and half dog clutch assembly which engages with the splines of the clutch gear and meshes with the wheel

RESTRICTED

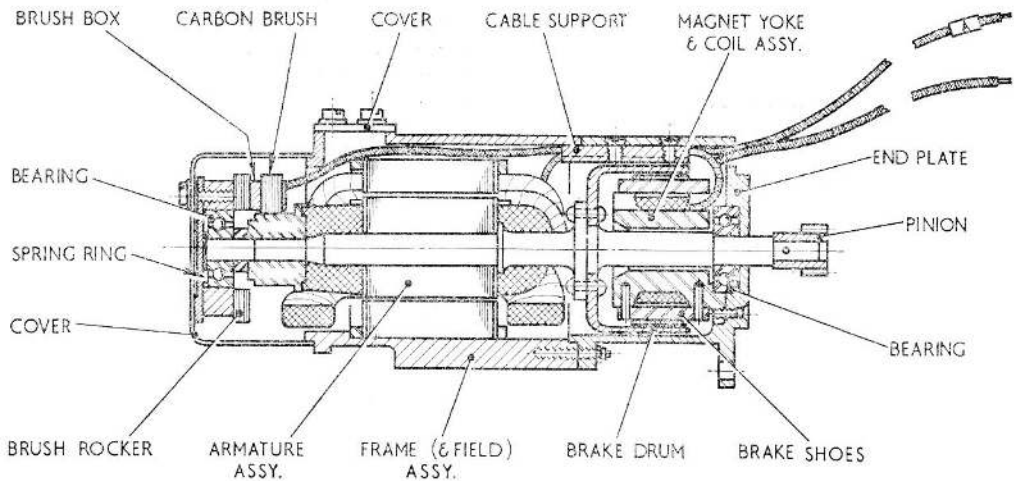

Fig. 2. Section of motor

of a compound gear. The pinion of the compound gear meshes with a third (and final) reduction spur wheel. This spur wheel is secured to an actuating screw which has a four start acme thread. The actuating screw engages with an actuating nut (ram) similarly threaded which provides the linear motion of the actuator.

9. The actuating screw and compound gear are supported in ball bearings whilst the clutch gear and coupling is supported in a bearing bush at one end and a ball bearing at the other.

Clutch magnet assembly

10. The magnet assembly is fixed to the gearbox end-cover and consists of a wire wound toroidal coil enclosed by a magnetic iron housing and base.

11. Through the centre of the magnet assembly there is a magnetic iron plunger secured to a push rod and these are free to move inside the magnet assembly. A sleeve bearing is fitted next to the push rod which is also free to move with the push rod.

12. The sleeve bearing supports one end of a gear pin which carries the half dog clutch and clutch gear; the other end of the gear pin is supported in a ball bearing.

13. When the magnet coil is energized the plunger is attracted towards the magnet base. This causes the push rod to slide towards the gear box pushing the sleeve bearing and half dog clutch along the gear pin and to engage the half dog clutch with the clutch gear.

14. When the magnet coil is de-energized the plunger, push rod, sleeve bearing and half dog clutch return to their original positions under the action of a spring fitted between the half dog clutch and clutch gear.

Limit switch box

15. The switch box is fitted to the gearbox and is divided into two compartments, one containing two limit micro switches located side by side, and the other a junction block for the leads from the motor, clutch and limit switches.

16. The switch box encloses the actuating screw and nut (ram) which runs through the centre of the box. A switch block is secured to the ram which, as the ram reciprocates, operates the limit switch operating arms.

Housings

17. With the exception of the clutch housing all housings and covers are of aluminium

RESTRICTED

alloy. The gear train, switches and motor are completely enclosed, and the housings consist of a gearbox, gearbox end-cover, switch box and covers, motor frame, end-plate and end cover.

OPERATION

18. Suppose that the ram is in the fully retracted position and the electrical supply is switched off: the clutch is disengaged, the motor brake shoes are pressed against the brake drum preventing rotation, the retract limit switch is depressed i.e. open, and the extend limit switch is free i.e. closed.

19. If now a 28 volts d.c. supply is applied to terminals 1 and 2 on the terminal block, immediately, the clutch coil is energized causing the plunger and push rod in the magnet assembly to move towards the gearbox and engage the clutch; the motor brake coil is energized attracting the brake shoes away from the brake drum, leaving the armature free; the motor field coils are energized and hence the armature rotates driving the gear train and extending the ram.

20. After 0.15 in. movement of the ram the retract limit switch lever is released by the switch block and the switch closes. As the ram reaches the end of the extend travel the extend limit switch lever is operated and opens the switch. This cuts the electrical supply to the motor and brake only. The brake shoes are released and the armature stops almost instantaneously. The clutch remains in the engaged position owing to the clutch coil still being energized.

21. If now the electrical supply is switched off at the terminals the clutch coil de-energises and therefore the clutch disengages. The ram is now free to retract and this would normally be carried out automatically by the external load of the aircraft rudder lock on the end of the ram. Retraction of the ram in this way is made possible by the four start thread on the ram and actuating screw, which drives the gearing in the reverse direction.

22. On the retract stroke the extend limit switch closes as soon as the ram moves from its fully extended position. When the ram is within 0.15 in. of being fully retracted the retract limit switch opens.

23. When the actuator is installed in the aircraft, a warning lamp is permanently wired through terminal 3 on the actuator terminal block to the retract limit switch; the lamp lights only when the ram is further than 0.15 in. from the fully retracted position.

INSTALLATION

24. If it is necessary to adjust the actuator centres, slacken the plug end locking nut, and screw the plug end in or out of the ram as required. Note, however, that the plug end should have at least $\frac{1}{8}$ in. thread engagement with the ram. To ensure this a $\frac{1}{8}$ in. diameter safety hole is provided towards the end of the ram; a piece of 17 SWG wire inserted into this hole must not enter more than $\frac{1}{8}$ in.

SERVICING

25. The actuator should be examined and serviced according to the instructions given in the appropriate Servicing Schedule.

General

26. Ensure that the actuator and its fixings are clean. Examine for external damage such as cracked housings, and for corrosion. Check the security of all external nuts, bolts and of the electrical connections. Ensure that there are no frayed or perished leads.

Brushgear

27. Remove the motor end cover and thoroughly clean the brush gear and the inside of the cover; make sure that all traces of carbon dust are removed.

28. Lift out the carbon brushes and examine them for damage, and measure their overall length. Damaged brushes or those worn down to 0.175 in. or beyond must be renewed.

29. Check that the brush spring pressure is between 4 and 5 oz. per brush. Using a spring balance and measure the pressure when the end of the spring arm is raised level with the top of the brush box. When fitting new brushes ensure that they are free in their respective holders.

RESTRICTED

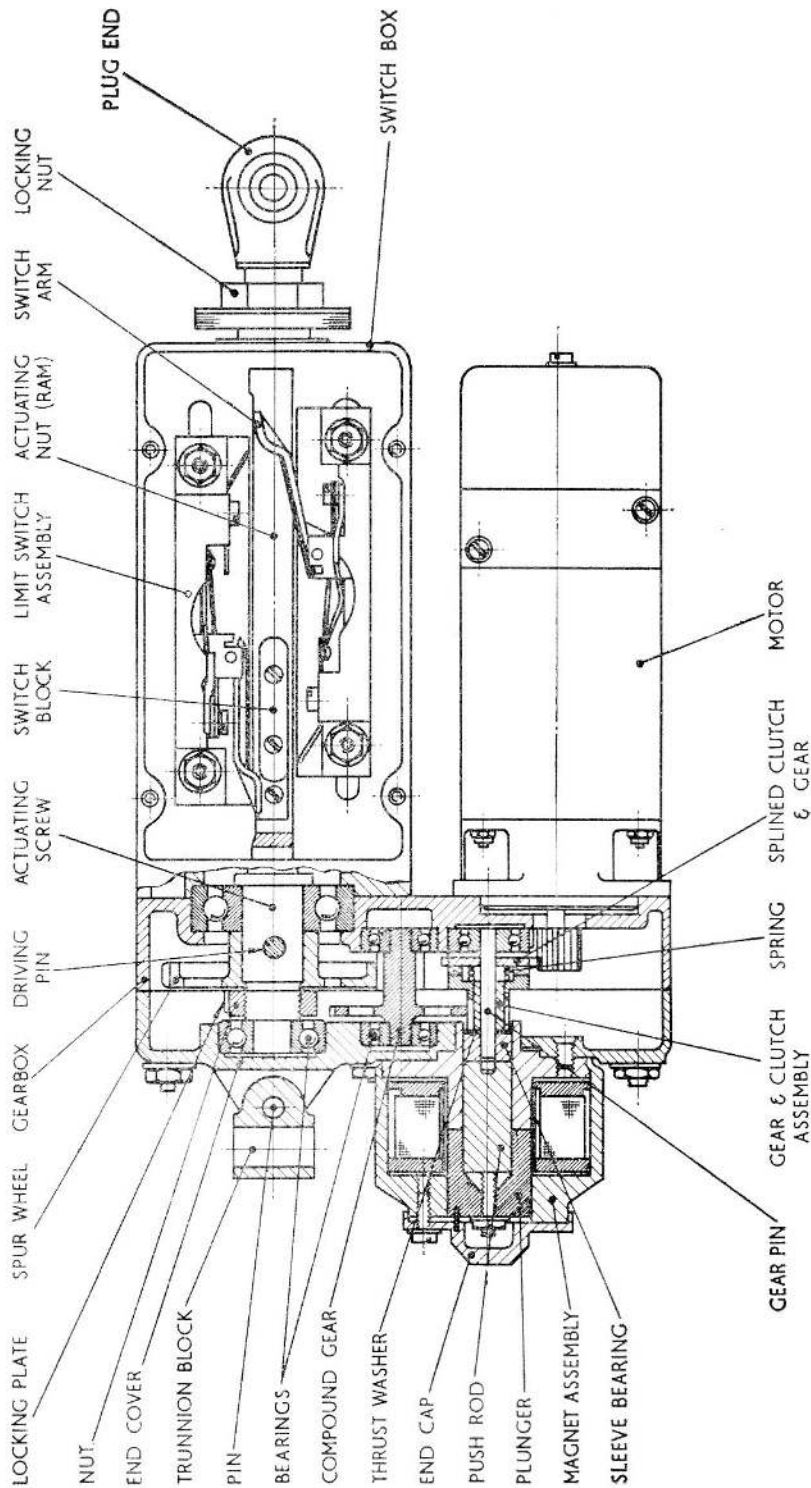

Fig. 3. Section of actuator

RESTRICTED

30. New brushes should be bedded to the contour of the commutator for at least 80% of their contact area.

Commutator

31. The commutator should have a smooth polished surface with a low resistance oxide film. If the surface is found to be badly scored, grooved, burnt or discoloured the armature should be removed so that the commutator may be skimmed between lathe centres.

32. Skimming should be carried out by using a diamond tipped tool, and running the armature at 4500 rev/min. Ensure that the finished diameter is not below 0.595 in. Ensure also that the surface finish of the commutator does not exceed 8 micro inches and that its diameter is concentric with the bearing seats to within 0.0005 in. T.I.R.

Bearings

33. All bearings are correctly lubricated during initial assembly and do not require further attention until the actuator is removed for overhaul.

34. During overhaul the motor bearings should be thoroughly cleaned and refilled with grease to XG-275. The grease should be evenly distributed and the amount used should be 0.03 to 0.05 c.c.

TESTING

Functional test

35. Carry out a functional test by inching the actuator to the extend position applying a reduced voltage 18 volts d.c. Check that the current consumption does not exceed 3.8A. Note that to retract the actuator the supply must be switched off and an external load of 100 lb exerted on the ram.

Insulation resistance test

36. After the functional test, whilst the motor is still warm, carry out an insulation resistance test. Use a 250 volt d.c. tester and take readings between the motor terminals and actuator frame; the values obtained should not be less than 0.05 megohms.

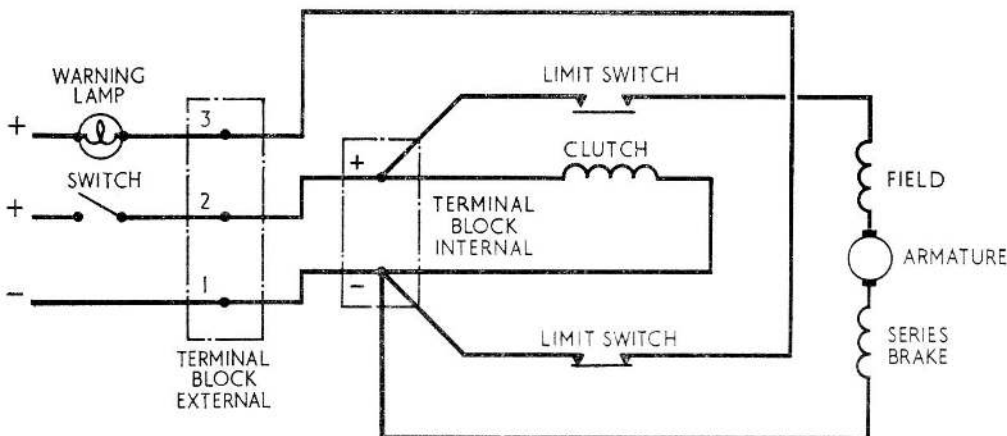

Fig. 4. Wiring diagram

RESTRICTED

This file was downloaded
from the RTFM Library.
Link: www.scottbouch.com/rtfm

Please see site for usage terms,
and more aircraft documents.

