

Chapter 89

ACTUATOR, ENGLISH ELECTRIC, TYPE AE4022, Mk. 1

LIST OF CONTENTS

	<i>Para.</i>		<i>Para.</i>
<i>Introduction</i>	1	Operation	
Description	2	<i>High Speed</i>	22
<i>Housing and covers</i>	6	<i>Low Speed</i>	23
<i>Gearbox</i>	11	Servicing	
<i>Acme screw and nut assembly</i>	14	<i>General</i>	24
<i>Potentiometer</i>	15	<i>Brushes</i>	26
<i>Motor and brake assembly</i>	16	<i>Lubrication</i>	27
Installation	20	<i>Functional test</i>	28
		<i>Clutch slip current check</i>	31
		<i>Clutch adjustment</i>	32

LIST OF ILLUSTRATIONS

	<i>Fig.</i>		<i>Fig.</i>
<i>General view of actuator, Type AE4022,</i>		<i>Wiring diagram (low speed motor)</i>	3
<i>Mk. 1</i>	1	<i>Installation drawing</i>	4
<i>Wiring diagram (high speed motor)</i>	2	<i>Test circuit diagram</i>	5
		<i>Dimensions of C spanners</i>	6

LEADING PARTICULARS

Actuator, Type AE4022, Mk. 1	Ref. No. 5W/2080
<i>Rated voltage</i>	28V d.c.
<i>Speed of motors</i>	11000 rev./min
<i>Output of each motor</i>	356 watts
<i>Maximum working load</i>	
<i>High Speed</i>	8000 lb
<i>Low Speed</i>	16000 lb
<i>Normal working load</i>	3000 lb
<i>Static load (as an aircraft strut)</i>	27000 lb
<i>Clutch slip load</i>	
<i>At overhaul</i>	10500 to 12500 lb
<i>During service</i>	10500 to 18500 lb
<i>Normal working stroke</i>	1.613 in
<i>Stroke between stops</i>	1.83 in
<i>Time of stroke</i>	
<i>Normal load (high speed)</i>	6 seconds
<i>Normal load (low speed)</i>	17 seconds
<i>Distance between centres (closed on stops)</i>	14.615 in
<i>Brushes</i>	
<i>Grade</i>	E.G.O. (H.A.M.)
<i>Spring pressure</i>	11 to 15 oz
<i>Minimum length</i>	7/16 in
<i>Weight</i>	31 lb

RESTRICTED

Introduction

1. The linear actuator, Type AE4022, Mk. 1 (fig. 1), is similar to the Type 271 actuator and has been designed to provide variation in the angle of incidence of the tailplane under all conditions of flight. It is a two speed actuator; at high speed a working load of up to 8000 lb can be handled, and at low speed this load increases to a maximum of 16000 lb. Acting as a strut in the air frame, it can withstand loads of up to 27000 lb both in tension and compression.

DESCRIPTION

2. The actuator includes two identical 28V d.c. compound wound motors mounted side by side, and parallel to the ram. Each motor is fitted with an electro-magnetic brake to ensure accurate positioning at any point during the stroke. By means of a differential arrangement of spur and epicyclic gears the two motors drive independently, thus providing two speeds of operation. The final spur is splined to an acme screw, which, through its mating thread on the ram, provides a linear movement.

3. Although mechanical stops are provided, the unit must always be used with external limit switches, so preventing running against the mechanical stops unnecessarily.

4. The gearbox incorporates an overload friction clutch. Thus, in the event of limit switch failure, or any other cause of severe

overloading, the air frame or actuator is not damaged.

5. A position indicator potentiometer is mounted in the unit and is intended for use with a Desynn type instrument.

Housing and covers

6. Each motor housing consists of two alloy castings, and a brushgear and commutator inspection cover. One casting forms the motor field system frame and brushgear mounting, whilst the other forms the brake housing and driving end plate. Both castings are held together by four steel bolts. Positioned on the motor frame casting is a cable gland, and mounted on this is a Breeze plug.

7. The two motors are located on an adaptor plate, through which studs pass into the gear case.

8. The gear case comprises two alloy castings which form the front and rear halves. They are held together by ten steel studs.

9. The ram housing is an alloy casting enclosing the acme screw and nut assembly and the potentiometer indicator transmitter. It is held on the gear case by four studs. The ram shackle is a fork end on the end of the acme nut and positioned in line with it, but at the opposite side of the gearbox, is another steel fork end and universal lug. The fork end is held on the gear case by eight bolts.

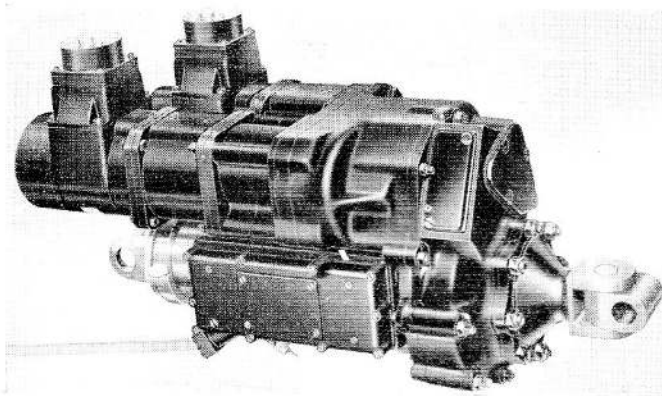

Fig. 1. General view of actuator, Type AE4022, Mk. 1

RESTRICTED

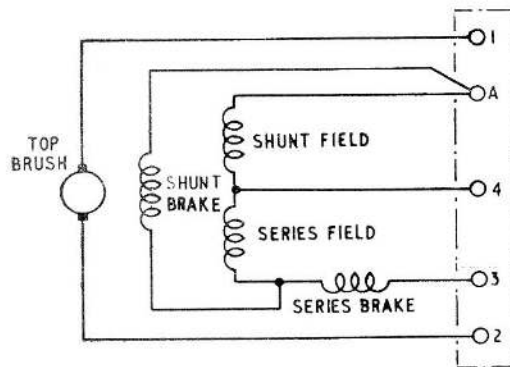

Fig. 2. Wiring diagram (high speed motor)

10. An alloy side cover on the ram housing serves to mount the potentiometer, and also seals it into the housing. On the ram housing opposite to the potentiometer is a steel lipped cover over the slot containing the torque reaction arrangement.

Note . . .

The actuator should never be operated without this cover in position.

Gearbox

11. Using a pinion mounted on the armature shaft, the high speed motor drives direct into an epicyclic gear system and then by spur gears to the acme thread.

12. The low speed motor also has a pinion mounted on the armature shaft. This drives

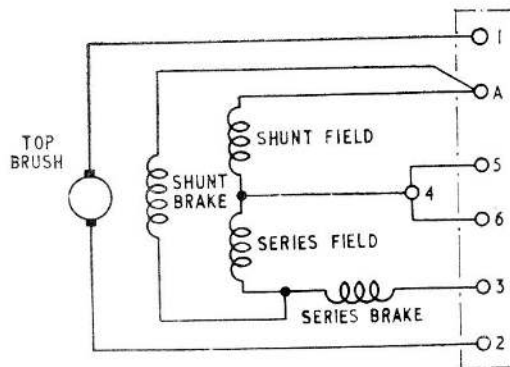

Fig. 3. Wiring diagram (low speed motor)

a spur gear system and then engages with the epicyclic gear system as in the high speed motor. When one motor is running the other is locked by its brake.

13. The clutch is of the multi-plate type. Its main shaft carries an input spur gear, and if the clutch is not slipping (due to overload) the drive is transmitted to an output spur gear. Both of these spur gears form part of the spur gear system mentioned in para. 11.

Acme screw and nut assembly

14. This assembly consists of an aluminium bronze acme nut, a hollow steel screw and a hollow sleeve which travels inside the screw. The hollow sleeve is screwed and pinned to the ram shackle, the shackle being screwed into and keyed to the end of the acme nut, the inner face of this shackle forming the retracted mechanical stop face. The minimum length of the thread engagement between the acme nut and ram shackle is indicated by the safety hole. When the shackle is in safety it is not possible to insert a piece of wire of 0.60 in dia. to a depth greater than 0.130 in. The acme nut is prevented from turning by a torque reaction lug.

Potentiometer

15. The potentiometer is of the usual type associated with Desynn type instruments. There is an adjusting screw tapped into the mounting board, and captive in the cover. By turning this screw the position of the coils relative to the acme thread can be adjusted. The leads are brought out to a terminal block, situated under a removable plate in the centre of the cover. The cable enters by way of a gland and clamping plate.

Motor and brake assembly

16. Essentially, both motors are exactly the same, but the plug connections are purposely made non-interchangeable (fig. 2 and 3).

17. The designed output is 356 watts at 11000 rev/m²n 28V d.c. supply. The windings are compound, and reversal of rotation is effected by external switch gear.

18. The two alloy brush boxes are mounted on a moulded rocker. This is adjustable for setting the neutral position. The brushes are E.G.O. (H.A.M.) type, and are held in contact by coiled wire springs. Brush spring pressure must be 11—15 oz.

19. A brake drum is fixed to a flange on the armature shaft, and the brake yoke is fixed in the end plate. With the current off, four shoes are held against the brake drum thus preventing any rotation of the motor.

INSTALLATION

20. The distance between centres at the ram shackle and the universal lug (*para.* 9), with the actuator fully closed up on the stops, should be 14.615 ± 0.015 in. The stroke between the stops should be 1.83 ± 0.015 in.

21. Before the actuator is brought to the mounting, the alignment of the mounting lug, should be checked. The neutral position on the Desynn indicator should be obtained when the actuator is in its neutral position by suitably setting the potentiometer adjusting screw.

OPERATION

High Speed

22. For high speed operation, the low speed motor armature is locked. Therefore the high speed drive is straight from the motor, through the epicyclic gear and spur gear train, on to the acme screw.

Low Speed

23. For low speed operation, the high speed motor is locked. The drive is now through the first train of spur gears, on to the epicyclic gear, through the second train of spur gears, and thus to the acme screw.

Note . . .

The actuator must only be operated in a test rig or on an aircraft where external limit switches are incorporated in the circuit

SERVICING

General

24. The actuators should be serviced in accordance with the relevant Servicing Schedule; no servicing other than that detailed should be attempted.

25. Examine the actuators for any signs of external damage. Ensure that all nuts, screws, and locking devices are secure. Examine the electrical connections for tightness and freedom from corrosion. Ensure that that wiring is not frayed or loose. Care should be taken to ensure adequate application of sealing compound to joint faces when covers are refitted.

Note . . .

It should be noted that this actuator contains mated assemblies, before replacing any component.

Brushes

26. The brushgear should be examined at the periods stated in the relevant Servicing Schedule. On removal of the two commutator-end covers the brushes are readily accessible. Each brush should be a free fit in its box, and any accumulation of carbon should be carefully blown away with dry compressed air. The minimum brush length (measured from the top of the brush to the toe of the contact surface arc) is 7/16 in. If the brush length is below this or if the rate of wear indicates that the minimum length will be reached before the next servicing period or examination the actuator should be returned to a Repair Depot in accordance with current authorized instructions. The brush spring tension measured on a spring balance (Ref. No. 1H/97) should be between 11 and 15 oz.

Lubrication

27. The cover plate on the opposite side to the potentiometer should be removed and the acme screw lubricated with grease XG-278. No lubrication is necessary to either gearbox or motor between overhaul periods.

RESTRICTED

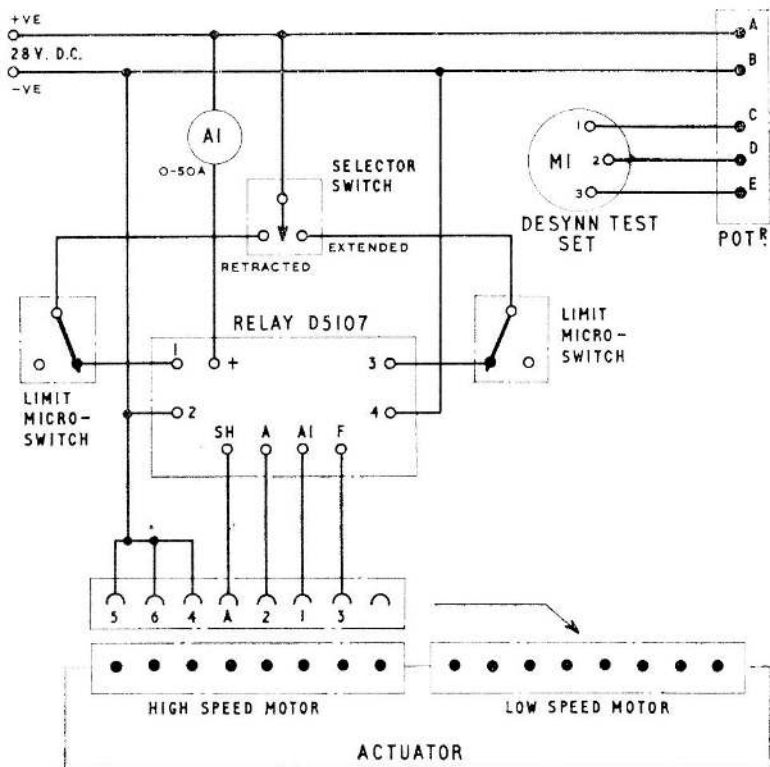

Fig. 5. Test circuit diagram

Functional test

28. Mount the actuator on a suitable travel setting rig with the limit switches arranged so that they operate $\frac{1}{4}$ in. from the fully extended and retracted positions, and connect to the test circuit as shown in fig. 5.

29. With the low-speed motor connected, run the actuator to the extended limit and then to the retracted limit. The current consumption should not exceed 9 amperes and the potentiometer operation, as indicated by MI, should show a smooth reading over the full range of travel.

30. With the high-speed motor connected repeat the test given in para. 29 and check that the current consumption is not in excess of 10 amperes.

Clutch slip current check

31. At overhaul periods a check should be made on the current at clutch slip as follows.

(1) Remove the brushgear and commutator cover, and remove the small rectangular cover from the gear case to reveal the clutch.

(2) Using a 14V d.c. supply, inch the actuator ram on to its extended mechanical stop.

(3) Connect the actuator to a 28V d.c. supply and ensure that the clutch slips. The current taken by the motor under this condition should not be less than 25A or more than 35A.

If the current consumption is outside the limits quoted in sub. para. (3) the clutch should be adjusted by following the instruction given in para. 32.

Note . . .

When the clutch is slipping the clutch housing will be stationary and the commutator will still be turning. The clutch slipping condition should not be maintained for more than 15 seconds.

RESTRICTED

Clutch adjustment

32. The clutch should be adjusted so that the current consumption is within the limits of 25A and 35A. Reference should be made to fig. 6 for dimensions of the C spanners which are required to fit the clutch body and the clutch adjusting locknut. The procedure for clutch adjustment is as follows.

- (1) Using the two C spanners unlock the locknut by holding the clutch body with one spanner and turning the nut with the other.

Note . . .

To increase or decrease the clutch slip, turn the adjusting nut clockwise or counter-clockwise respectively.

One slot of the adjusting nut gives a change of approximately 3A.

- (2) After adjustment tighten and lock the locknut and check the current at clutch slip as detailed in para. 31, sub para. (2) and (3).

Note . . .

During normal service life changes in clutch slip may occur, therefore for any periodic check between overhauls and for acceptance tests the current values of 25 to 45 amperes are acceptable.

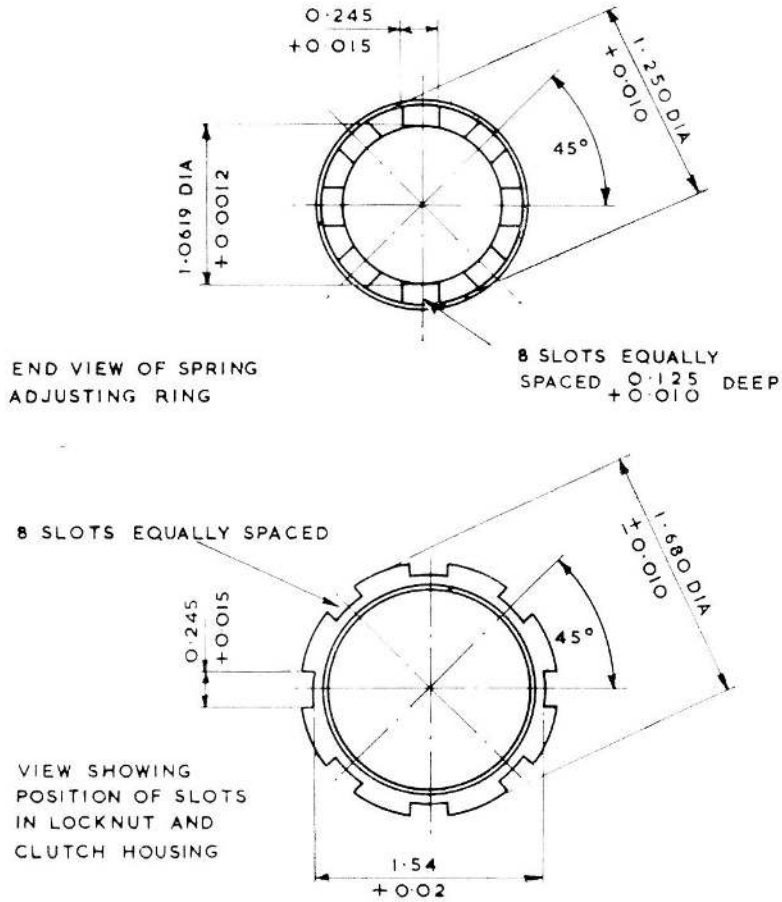

ALL DIMENSIONS IN INCHES

RESTRICTED

This file was downloaded
from the RTFM Library.

Link: www.scottbouch.com/rtfm

Please see site for usage terms,
and more aircraft documents.

