

## Chapter 92

## ACTUATOR, ENGLISH ELECTRIC, TYPE AE4027, Mk. 1

## LIST OF CONTENTS

|                                       | <i>Para.</i> |                             | <i>Para.</i> |
|---------------------------------------|--------------|-----------------------------|--------------|
| <i>Introduction</i> .....             | 1            | <i>Limit switches</i> ..... | 28           |
| <b>Description</b> .....              | 2            | <i>Potentiometer</i> .....  | 30           |
| <i>Housing and covers</i> .....       | 4            | <b>Installation</b> .....   | 32           |
| <i>Motor and brake assembly</i> ..... | 14           | <b>Operation</b> .....      | 36           |
| <i>Gearbox and clutch</i> .....       | 20           | <b>Servicing</b> .....      | 43           |
| <i>Actuating nut and screw</i> .....  | 25           |                             |              |

## LIST OF ILLUSTRATIONS

|   | <i>Fig.</i> |  | <i>Fig.</i> |
|---|-------------|--|-------------|
| <i>General view of actuator, Type AE4027,<br/>Mk. 1</i> ..... | 1           | <i>Sectional view of actuating nut and<br/>screw mechanism</i> ..... | 4           |
| <i>Sectional view of actuator</i> .....                       | 2           | <i>Internal wiring diagram</i> .....                                 | 5           |
| <i>Sectional view of potentiometer housing</i> .....          | 3           | <i>Installation drawing</i> .....                                    | 6           |

## LEADING PARTICULARS

|   |                         |
|---|-------------------------|
| <b>Actuator, Type AE4027, Mk. 1</b> .....                             | <b>Ref. No. 5W/2711</b> |
| <i>Rated voltage</i> .....  | 28V d.c.                |
| <i>Speed of motor</i> .....   | 11000 rev/min           |
| <i>Maximum working load</i> .....                                     | 200 lb                  |
| <i>Normal working load</i> .....                                      | 100 lb                  |
| <i>Static load (as an aircraft strut)</i> .....                       | 800 lb                  |
| <i>Clutch slip load</i> .....   | 250—350 lb              |
| <i>Normal working stroke</i> .....                                    | 2.75 in                 |
| <i>Stroke between mechanical stops</i> .....                          | 3 in                    |
| <i>Time of normal working stroke</i> .....                            | 8 sec max               |
| <i>Distance between centres (on "retract" limit<br/>switch)</i> ..... | 7.63 in                 |
| <i>Minimum brush length</i> .....                                     | 0.25 in                 |
| <i>Brush spring pressure</i> .....                                    | 4—5 oz                  |
| <i>Brush grade</i> .....  | E.G.O. (H.A.M.)         |
| <i>Weight</i> .....   | 3 lb 8 oz               |

## Introduction

1. The linear actuator, Type AE4027, Mk. 1, has been designed for use as a control trimmer on aircraft. It will operate in both directions up to an emergency load on the actuator of 200 lb.

## DESCRIPTION

2. The actuator consists of a two-pole, split series wound field, 28V d.c. motor. It is fitted with an electro-magnetic brake to prevent excessive overrun after the limit switches have cut off the supply to the motor (*para.* 40). The drive from the motor to the ram is provided by an arrangement of spur gearing, which incorporates a slipping clutch (*para.* 23). The final gear is secured to the actuating screw, which, through its mating acme thread on the actuating nut, provides linear motion.

3. A linear potentiometer is fitted, which, in conjunction with a ratiometer type instrument, indicates the position of the actuating nut (ram) at any time during its stroke.

### Housing and covers

4. The actuator housing is in four main sections: the motor, gearbox, gearbox end cover, and potentiometer box.

5. The motor is a detachable self contained unit and is housed in four light alloy parts. The armature, field coils, brush gear, and the commutator end bearing, are housed in the motor frame. The brake assembly, the driving end bearing, and the armature extension shaft are however fitted in the brake housing. The bearing for the extension shaft is housed in the drive end endplate, and locked in position by the brake yoke.

6. The drive end endplate serves as a location for the motor to the gearbox housing. The end cover, concealing the brush gear and commutator end bearing, is fixed to the motor frame by two small screws and lock-washers; the cover may be withdrawn completely clear of the brush gear for inspection purposes.

7. The motor frame, brake housing and drive end endplate, are fitted with wiring ducts, and, when fitted together, a continuous duct is formed through which pass the supply leads to the motor.

8. The motor frame and brake housing are held together by four studs and nuts.

9. The gearbox housing and the gearbox endcover are both light alloy castings. These contain the three stage reduction spur gear train, and the end of the actuating screw and its bearings. The studs for securing the gearbox endcover are screwed into the side of the housing, the studs for securing the motor unit being screwed into the opposite side of the housing. A bearing cap housing the bearing for the first stage reduction gear, and the spring for the slipping clutch, is secured to the gearbox end cover by three screws and locked with wire.

10. Integral with the front end of the end cover, and in line with the actuating screw (ram), is the trunnion block assembly, which is used as one of the two mounting points on the actuator. The other mounting point is the plug end assembly (incorporating a self-aligning bearing) attached to the end of the actuating nut (ram).

11. Cast in the gearbox housing is a wiring trough to enable the leads from the motor to be passed through to the limit switches.

12. The last component of the actuator housings is the potentiometer box which is a magnesium alloy casting and contains the actuating screw, the actuating nut, the limit switch assemblies, the mechanical stops, and the potentiometer assembly. A cork seal is fitted between the box and cover to prevent ingress of foreign matter and the egress of oil.

13. The potentiometer box is divided into two compartments, one for the limit switches and one for the potentiometer, each compartment being sealed with a cover. The cover is secured in position with four studs and nuts, after final adjustments have been made to the switches and potentiometer. An inspection plate for the potentiometer is held in position on the side of the box by two small screws.

### Motor and brake assembly

14. The motor is a two-pole split series wound 28V d.c. machine. There are four field windings, two on each pole piece: one pair is used in retracting the ram, the other pair to extend it. Connected in series with

RESTRICTED

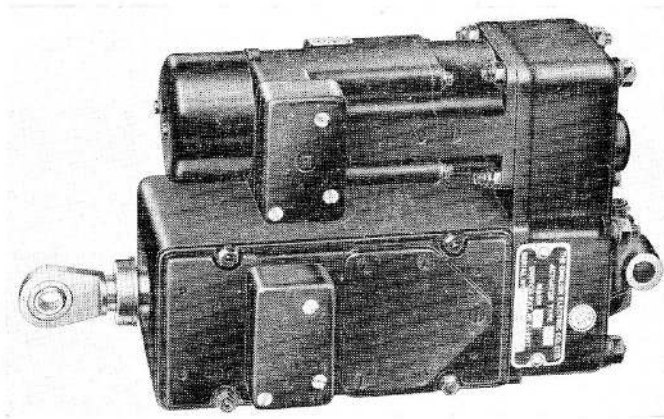

**Fig. 1. General view of actuator, Type AE4027, Mk. 1**

each pair of field coils is a limit switch (*para.* 28) to cut off the supply to the motor at the end of the stroke.

**15.** The yoke and pole pieces, being made up from one set of laminations, are integral with one another. Two brushes are mounted in brass brush boxes which are in turn mounted on a moulded brush rocker. The brushes are held against the commutator under pressure exerted by a flat coiled spring reacting against a brush finger which in turn bears on top of the brush.

**16.** The brush rocker is adjustable for setting the neutral position. The brush spring pressure should be between 4—5 oz (*para.* 47).

**17.** A brake drum is fitted to a flange on the armature shaft and the brake yoke is attached to the drive end endplate by four screws.

**18.** With the current off, four brake shoes, prevented from rotating by pins located in the brake yoke, are held against the steel brake drum, under the action of helical springs, thus preventing any rotation of the armature.

**19.** A three-way terminal block is screwed onto a machined face at the commutator end of the motor frame. The motor leads are run along a wiring duct in the motor frame and brake housing, emerging through the

drive endplate. The leads are prevented from sagging onto the rotating brake drum by a support which is secured to the inside of the motor housing by two screws.

#### **Gearbox and clutch**

**20.** The gearbox contains a three-stage reduction spur gear train. The first pinion is pinned to the armature shaft and drives the input gear to the slipping clutch. If no slip occurs (due to overload), the clutch output pinion drives the gear wheel on a compound gear. The pinion of this compound gear meshes with the final spur gear of the train, which is secured to the actuating screw. Through the mating acme threads of the actuating screw and actuating nut (ram), linear motion is obtained.

**21.** The gear shafts are all mounted on ball bearings housed in the gearbox housing and gearbox endcover.

**22.** The final spur gear, attached to the actuating screw, is tightened up against the inner bearing face by a locknut and locked in position by a lock-washer. By doing this, any tendency to end float by the actuating screw is eliminated. This can best be seen pictorially in fig. 4.

**23.** Integral with the first reduction wheel is the female half of the dog clutch, the wheel being a press fit on the shaft. The male part of the clutch is integral with the

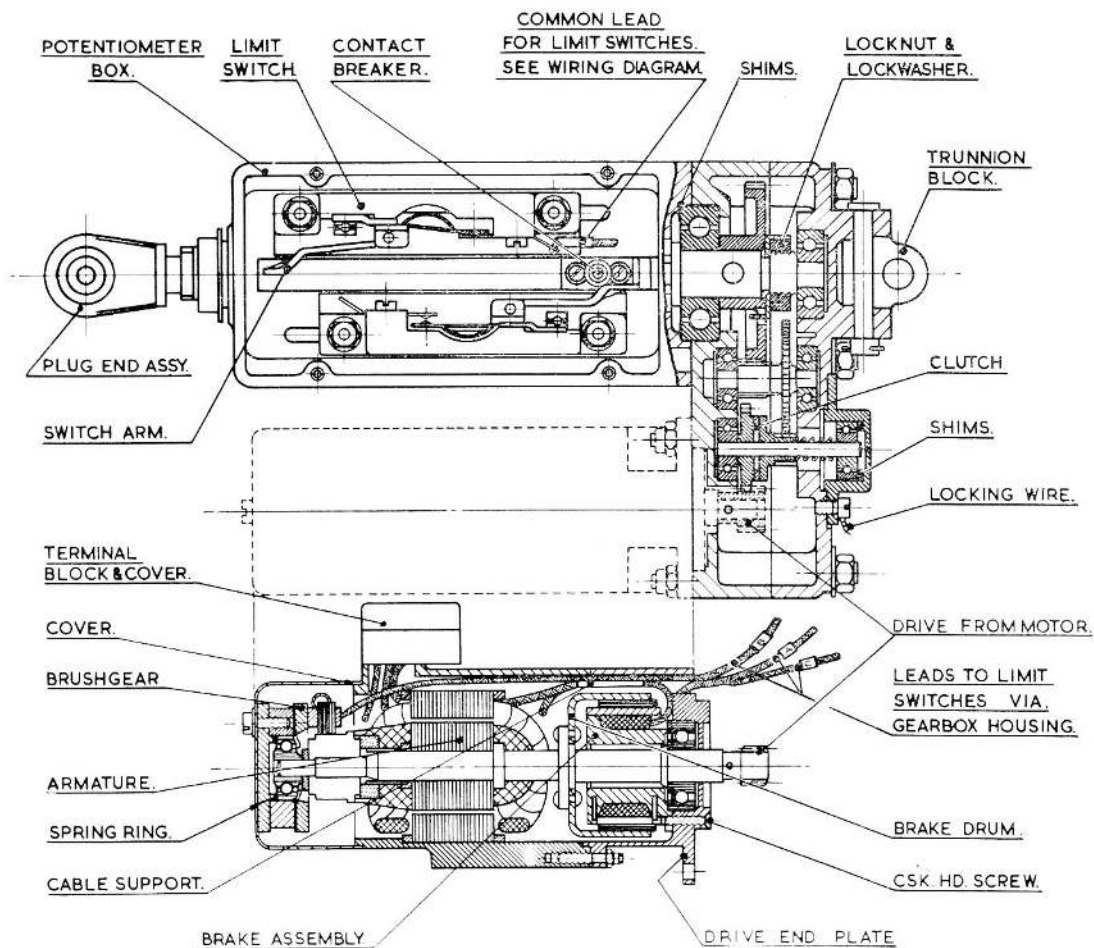

Fig. 2. Sectional view of actuator

second reduction pinion and is a sliding fit on the shaft. The pressure required to hold the two halves of the clutch in engagement is provided by a helical spring, situated between the bearing in the bearing cap and the end face of the pinion.

24. The clutch is set to slip under a load between 250 and 350 lb, and is incorporated to ensure that no damage is done to the actuator, or equipment to which it is mounted, in the event of an overload being accidentally applied to the actuator.

#### Actuating nut and screw

25. The actuating nut is driven by the actuating screw through the medium of the acme thread, the nut being threaded inter-

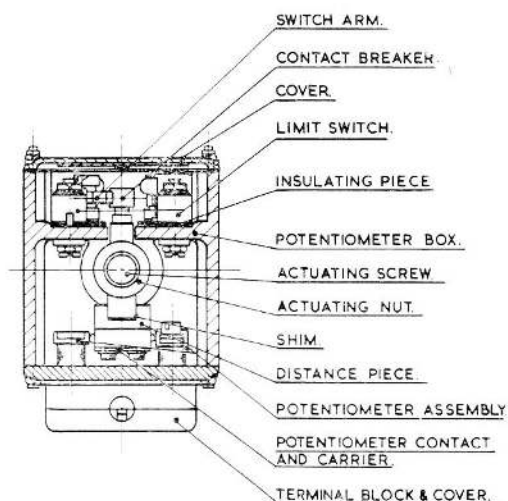

Fig. 3. Sectional view of potentiometer housing

nally for approximately one third of its length. At the opposite end to the acme screw the nut is screwed internally to accommodate the plug end assembly, used as one of the mounting points (*para. 32*).

26. At the gearbox end of the actuating nut (ram), an abutment is machined integral with the nut. This abutment slides in a slot machined in the potentiometer box, between the limit switch and potentiometer compartments, and prevents the actuating nut from rotating during its extension or retraction. The end of the slot is carefully machined to act as a mechanical stop in the event of limit switch failure when the actuator is extending. The "retract" mechanical stop is provided by the locknut on the plug end assembly.

27. Screwed to the abutment is the contact breaker which operates the limit switches (*para. 41*). Diametrically opposite the abutment in the potentiometer compartment, another abutment is machined on the actuating nut to carry the potentiometer slider contact.

### Limit switches

28. Each limit switch assembly is located in the limit switch compartment of the potentiometer box by two bolts fastened to a clamping plate situated on the underside of this compartment.

29. The limit switches are of the snap-action type. Each consists of two terminals,

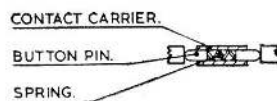
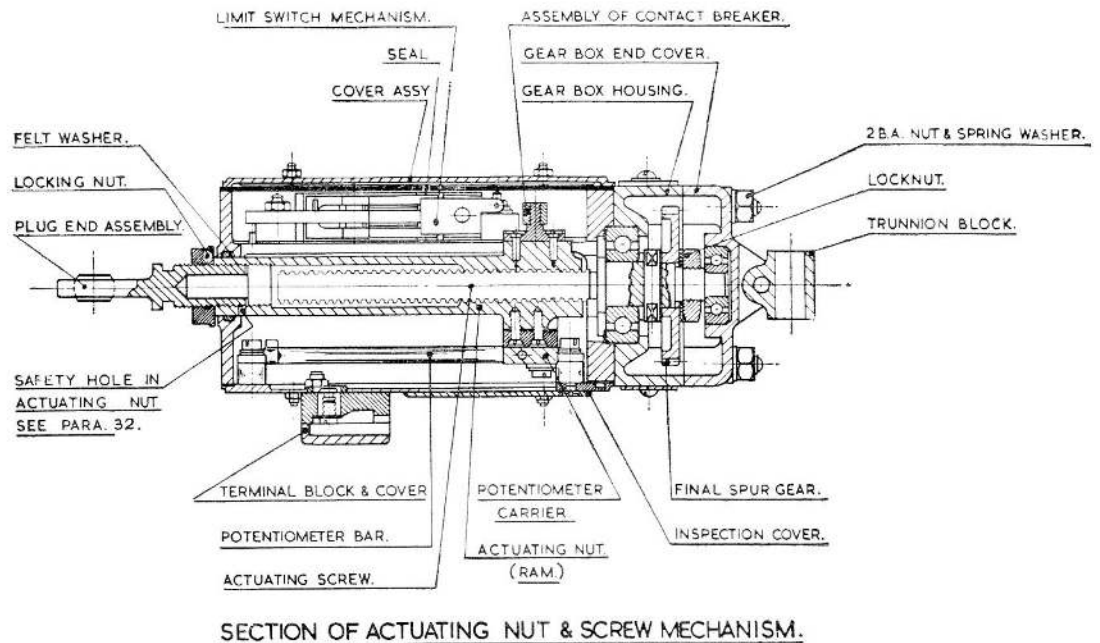

**Fig. 4. Sectional view of actuating nut and screw mechanism**

a trident spring moving contact manufactured from beryllium copper, and an operating switch arm which operates the switch on the simple lever principle. All these parts are secured to, or integral with, a moulded switch base.

### Potentiometer

30. The potentiometer assembly is shown in fig. 3. It is a position transmitter fitted for use with a remote ratiometer type indicator.

31. Between the potentiometer bars move sliding contacts. A small spring holds the contacts against the coils, thus providing constant pressure and good electrical contact. The sliding contacts are moved along by a carrier attached to the abutment on the actuating nut.

### INSTALLATION

32. The actuator is secured to the aircraft structure at two mounting points (the plug end and the trunnion block as mentioned in para. 10). The plug end assembly is adjustable. It is fitted with a locknut, and screws into the internal thread cut in the ram. By slackening the locknut, adjustment may be made to the retracted centre distance (between the mounting points) by screwing the plug end in or out as required.

#### Note . . .

*It is possible to screw out the plug end assembly to a point at which there is insufficient effective thread length on the plug end to carry the loads imposed upon it during normal operation. Therefore, should any adjustment be required, the following procedure must be adopted. On the ram is a safety hole (fig. 4). Always ensure that the screwed portion of the plug end assembly is screwed sufficiently in the ram to cover this hole. To check this a piece of  $\frac{1}{8}$  in. diameter wire should be pushed through the safety hole. If it penetrates to a depth greater than  $\frac{3}{8}$  in., the plug end assembly should be assumed to be "out of safety" and the centre distance re-adjusted.*

33. The distance between centres (on retract limit switch) is  $7.63 \pm 0.01$  in., and the stroke is  $2.75 \pm \frac{1}{8}$  in. This small adjustment is obtained by screwing the plug end in or out.

34. A practical wiring diagram of the motor and brake connections is provided in fig. 5. The motor terminals, numbered 1, 2 and 3, correspond to "common", "extend", and "retract", respectively, on this illustration.

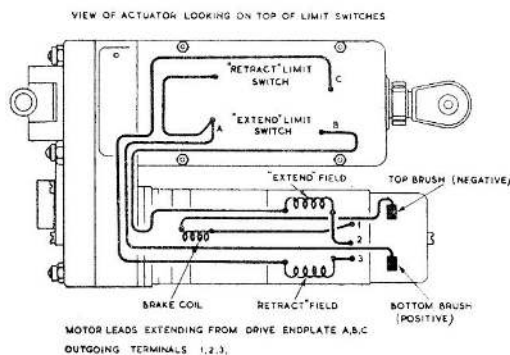

Fig. 5. Internal wiring diagram

35. The external connections to the potentiometer are made through the potentiometer box terminal block to terminals 1, 2, and 3.

### OPERATION

36. In the following text it is assumed that the actuator is fully retracted. In consequence, the "retract" limit switch is open and the "extend" limit switch is closed.

37. When the supply is switched on, the relevant pair of motor fields, and the brake coil, will be energized. The brake shoes will be pulled away from the brake drum allowing the armature to rotate.

38. With the armature rotating the pinion integral with the armature shaft meshes with the input gear of the half dog clutch. If no slip occurs, the drive is transmitted to the output pinion of the clutch which drives onto a compound gear. The compound gear mates with the final spur wheel of the train which is pinned to the actuating screw. Through the mating thread on the actuating nut (ram), the rotary motion of the final spur gear is converted to the linear movement of the ram, and the ram extends.

39. As soon as the actuating nut (ram) moves away from the fully retracted position, the "retract" limit switch will close. Now both limit switches are closed, and the actuator may be reversed at any time simply by altering the position of the remote circuit selector switch.

40. When the fully extended position is reached the contact breaker opens the "extend" limit switch, and thus the supply to the motor is cut off. The brake coil will be de-energized, and the brake shoes forced against the brake drum under the action of the brake springs, thus bringing the motor to an almost instantaneous stop.

41. The operation of the limit switches is effected by the contact breaker pushing against the switch arms which operate on the simple lever principle. Pressure from the switch arms is applied to the central part of the trident spring, causing snap action separation of the contacts.

42. Should an overload occur, or a limit switch fail (and the ram move up against a mechanical stop), the clutch will slip. The sustained high current will blow the fuse in the actuator supply line, thus breaking the supply to the motor.

### SERVICING

43. The actuator should be inspected, and serviced, in accordance with and at the periods specified in the appropriate Servicing Schedule.

44. For routine inspections, the external nuts, bolts, screws, etc., should be checked for security. The wiring should be checked for fraying leads, corrosion at the terminals, and security of the terminal screws and lead ends.

45. Access to the brushes is gained by removing the two screws securing the motor end cover, and removing the cover.

46. The brushes should be a free fit in the boxes. Worn brushes should be renewed before the minimum brush length limit is reached. Any accumulation of carbon dust should be carefully blown away with dry compressed air. If brush renewal is necessary, only brushes of the E.G.O. (H.A.M.) type should be used. These should be bedded down to the contour of the commutator for at least 80 per cent of their contact area.

47. Brush spring pressure should be checked using a spring balance (Ref. No. 1H/59). The value obtained should be between 4 and 5 oz.

48. Should adjustment of the brush spring pressure be necessary, the following method should be employed. Remove the brush box,

and push the splined spindle, to which the brush spring is anchored, through the brush box just far enough to clear the end of the splines. By turning the splined shaft in the appropriate direction, the adjustment to the brush spring pressure may be made. Afterwards replace splined shaft.

49. The limit switches may be adjusted for correct positioning and correct stroke. To gain access to the switches, remove the limit switch cover plate. The potentiometer cover, upon which the terminal block is mounted, must not be removed. Slacken the two nuts securing each switch assembly. The switches may now be adjusted.

50. After adjustment the switches should be secured in their new position by tightening the fixing nuts. A thin layer of sealing compound should be applied to the outer edges of the cover, which should be assembled with the compound still wet.

51. Access to the potentiometer is gained through the inspection cover which is secured by five 6 B.A. countersunk-head screws.

52. The potentiometer windings and contacts should be checked for freedom from grease, dirt, etc. Should any foreign matter exist on the potentiometer windings or contacts, they should be cleaned using wood backed crocus paper. Any dust remaining should be carefully blown away with dry compressed air.

53. The potentiometer windings should be electrically tested. Insulation test between windings and frame should be not less than 2 megohms using a 250V insulation resistance tester. Due to the humidity prevalent in aircraft at dispersal points the minimum permissible insulation resistance must not be below 50000 ohms.

54. The resistance of the winding between terminals 1 and 2 should be 500 ohms  $\pm$  7½ per cent. Check that on retract mechanical stop the resistance between terminals 2 and 3 is zero.

55. A functional check should be carried out after all servicing is completed.

### Note . . .

*It should be noted that this actuator contains mated assemblies, before replacing any component.*

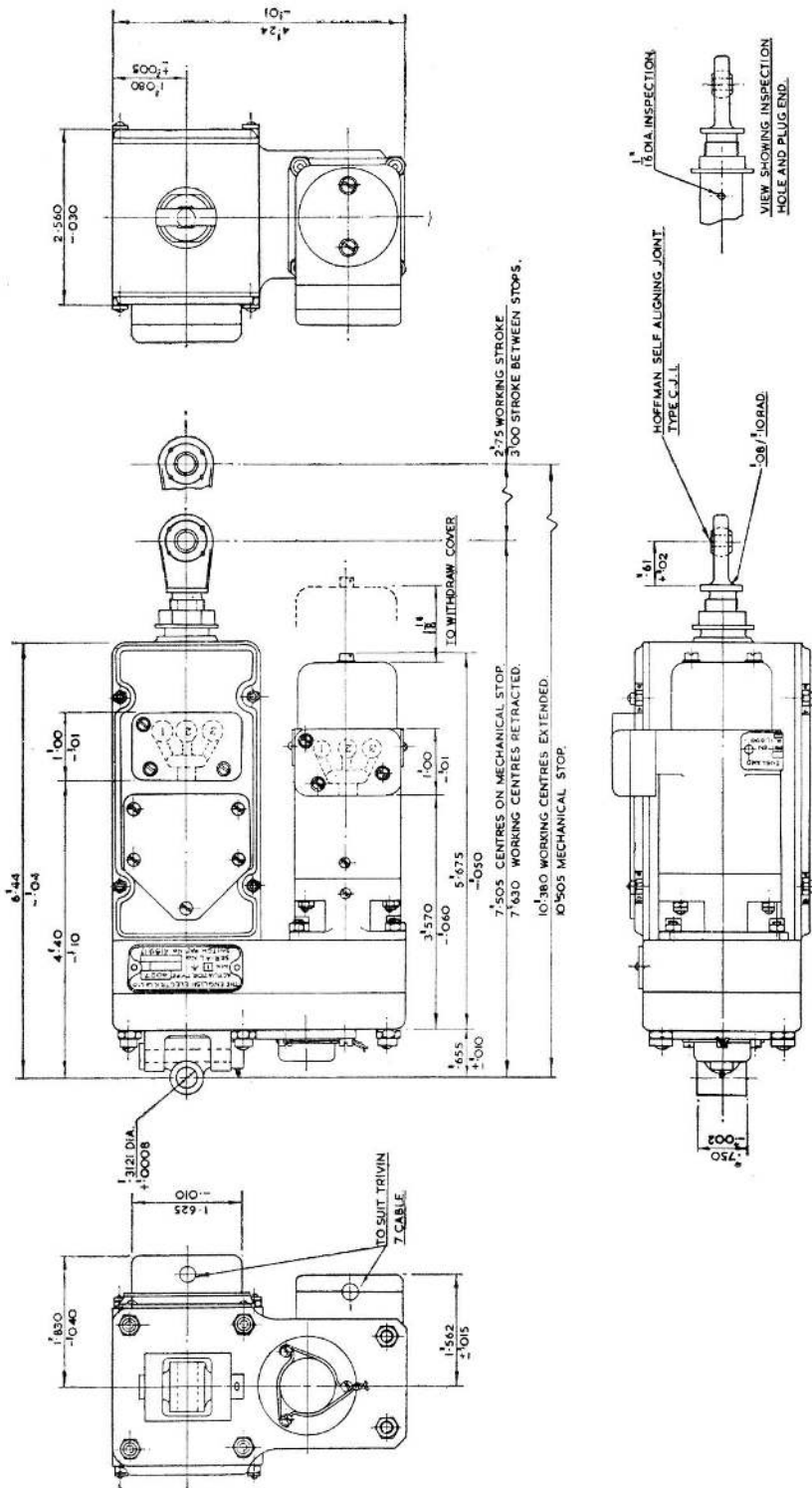

Fig. 6. Installation drawing

RESTRICTED

This file was downloaded  
from the RTFM Library.

Link: [www.scottbouch.com/rtfm](http://www.scottbouch.com/rtfm)

Please see site for usage terms,  
and more aircraft documents.

