

Chapter 93

PLESSEY, TWIN-MOTOR JAGUAR SERIES

LIST OF CONTENTS

	<i>Para.</i>		<i>Para.</i>
<i>Introduction</i>	1	<i>Limit switch assemblies</i>	12
Description		<i>Electrical connections</i>	17
<i>General</i>	2	Operation	19
<i>Motors</i>	5	Installation	21
<i>Reduction gear trains</i>	6	Servicing	25
<i>Leadscrew and plunger</i>	9	<i>Lubrication</i>	26
		<i>Testing</i>	27

LIST OF ILLUSTRATIONS

	<i>Fig.</i>		<i>Fig.</i>
<i>General view of twin-motor actuator</i>	1	<i>Limit switch assembly</i>	4
<i>Sectional view of twin-motor actuator</i>	2	<i>Circuit diagram</i>	5
<i>Reduction gear trains</i>	3		

LIST OF APPENDICES

	<i>App.</i>
<i>Standard serviceability test for actuator,</i> <i>Plessey, Type 1CZ 80383/1</i>	A
<i>Actuator, Plessey, Type 1CZ 80383/1</i>	1

RESTRICTED

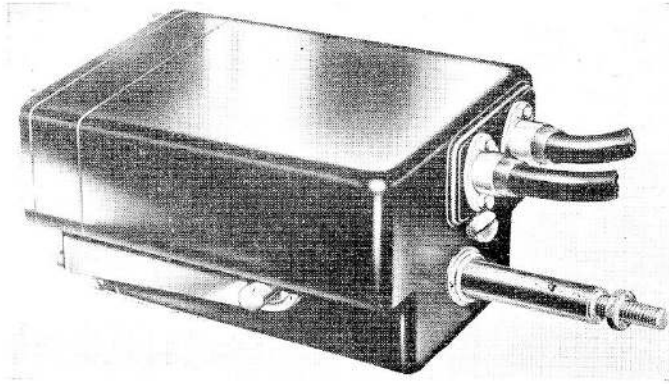

Fig. 1. General view of twin motor actuator

Introduction

1. Plessey linear actuators of the Twin-motor Jaguar series follow the general design described in this chapter. The actuator described here is the Plessey Type 1CZ 80383/1 and is typical of the series. Specific details of individual actuators will be found in appendices to this chapter.

DESCRIPTION

General

2. The actuators of the Twin-motor Jaguar series have an auxiliary motor mounted alongside the main motor, both motors being offset from the plunger.

3. The two motors are identical and are electrically independent of each other. The auxiliary motor is brought into use from the external control point, only in the event of a failure of the main motor, or, its limit switches.

4. Apart from the mounting gear arrangements and limit switches necessary for the two motors, the actuators are basically similar to the earlier Jaguar series, described in another chapter.

Motors

5. The motors are of the usual split-field, series-wound type incorporating an electromagnetic brake to prevent overrun of the plunger.

Reduction gear trains

6. The gear trains (*fig. 3*) consist of two initial spur gear reduction trains (main and auxiliary), and intermediate epicyclic type differential stage, and a final spur gear train, arranged to give a total ratio of 32:2: 1.

7. Normally, the main motor is energized and the drive from the main motor pinion to the planet gear assembly is through a gear secured to the forward end of the sun gear shaft. The auxiliary motor, being braked, serves to lock the annulus, and the drive is transmitted through the three planet gears and carrier to a small gear pinned on the rear end of the planet gear assembly shaft. The drive to the final drive gear on the lead-screw is then made through a gear and pinion on an intermediate shaft.

8. With the auxiliary motor selected, the drive from the auxiliary motor pinion to the planet gear assembly is through a gear secured to the forward end of the auxiliary drive shaft. A pinion on the rear end of the shaft meshes with teeth, cut on the periphery of the annulus. The main motor, being braked, serves to lock the sun gear, and the drive is transmitted through the planet gears and carrier to the final drive gear, as previously described for the main motor.

Leadscrew and plunger

9. The final drive gear is mounted on the

RESTRICTED

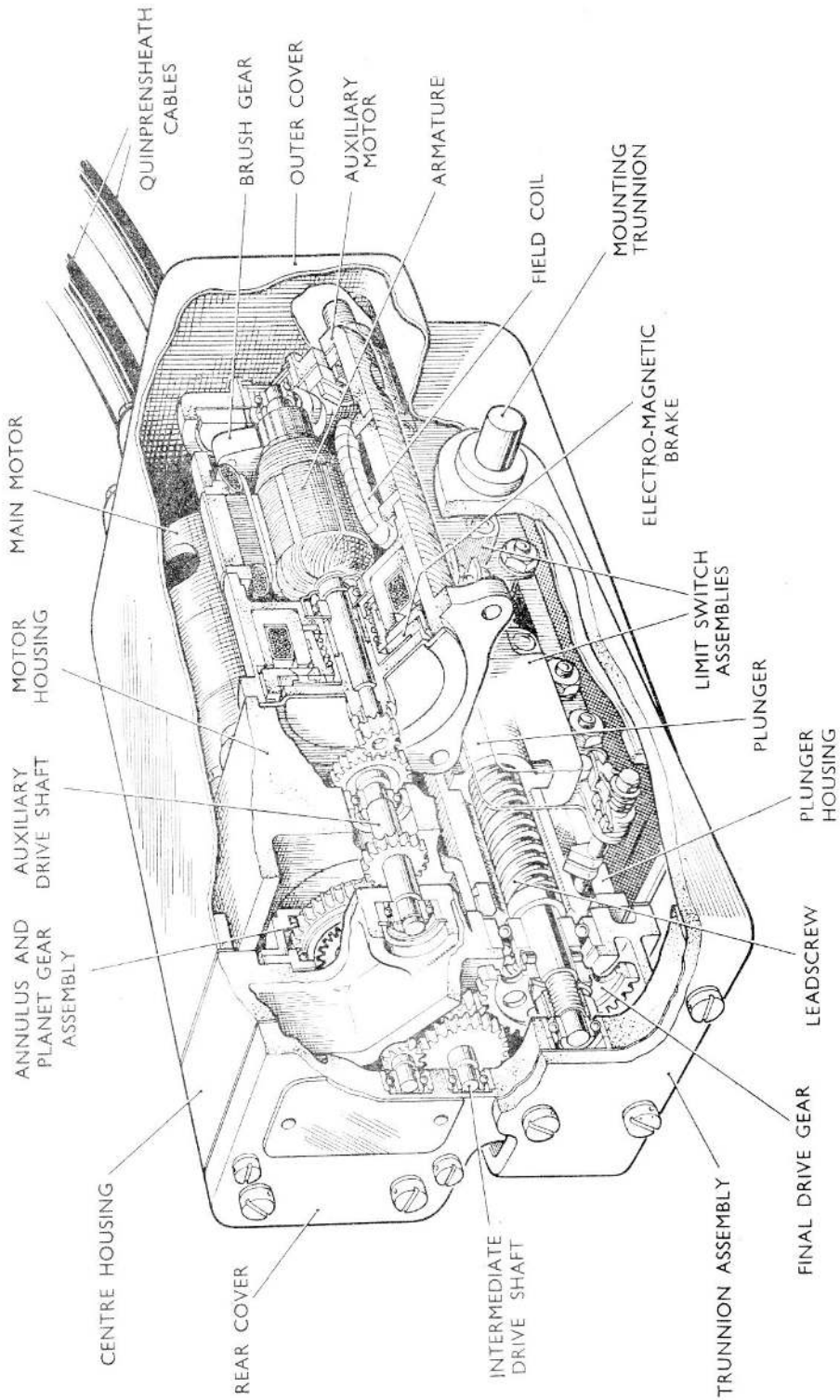

Fig. 2. Sectional view of twin motor actuator

RESTRICTED

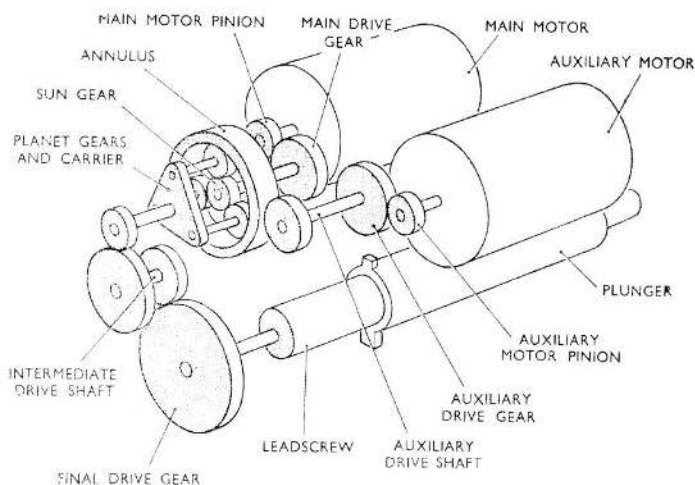

Fig. 3. Reduction gear trains

rear end of the leadscrew and the drive is transmitted through a drive pin which is inserted through the leadscrew. A 12 t.p.i. Acme-form thread is cut along the main length of the leadscrew and is a close mating fit with the similar thread on the inside of the plunger.

10. The plunger is prevented from rotating by two torque reaction ears, which travel in slots in the plunger housing. The travel of the plunger is established by two snap-action limit switches which are operated by the torque-reaction ears, thus interrupting the electrical supply at the extended or retracted position of the plunger.

11. The attachment for the front eye end is pinned in the forward end of the plunger.

Limit switch assemblies

12. Two limit switch assemblies are mounted on each side of the plunger housing to control the extended and retracted limits of plunger travel. The two on the left-hand side are in the main motor circuit and the two on the right-hand side are for the auxiliary motor.

13. Each switch assembly (*fig. 4*) consists of a limit switch, riveted to a mounting plate, and the switch operating mechanism. The trip arm, which is pinned to the inner end of the rocker spindle, is contacted by the lower

torque reaction ear on the plunger. Movement of the rocker spindle causes the rocker, which is integral with the spindle, to load the spring.

14. One end of the spring is located under a flange on the rocker and the other end under the tongue of the switch arm. When the rocker end of the spring is loaded, the load is transferred to the other end which then moves the tongue on the switch arm upwards to operate the limit switch button. Any further movement of the rocker is absorbed by the spring.

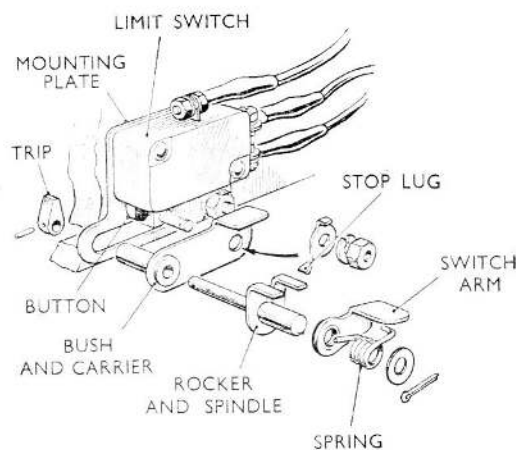

Fig. 4. Limit switch assembly

15. When the plunger moves away from the extreme position, the load on the spring is released and the switch arm moves downwards away from the limit switch button. Further downward movement of the switch arm is prevented by a lug on a tab washer under one of the securing nuts.

16. The switch assemblies are secured to the plunger housing by two nuts and special screws. Adjustment to the plunger stroke is made by slackening the securing nuts and sliding the switch assemblies in the appropriate direction along the slots in the plunger housing.

Electrical connections

17. The connections to each motor and its associated limit switch assemblies are made by a length of quinpresheath cable. The two cables protrude from the front of the outer cover.

18. The internal connections are shown in the circuit diagram in fig. 5.

OPERATION

19. Either of the reversible motors drives the leadscrew through a reduction train of

spur and epicyclic gears. Moving over this leadscrew is the plunger, which incorporates two torque reaction ears (or lugs), which move in locating slots in the enclosing plunger housing to prevent the plunger from rotating.

20. Dependent on the direction of rotation of the motor, therefore, the plunger extends or retracts in a linear motion within fixed limits. The extent of plunger travel is controlled by adjustable limit switches which are connected in the motor field circuits and are operated by one of the torque reaction ears. An electro-magnetic brake in each motor prevents overrun of the output shaft.

INSTALLATION

21. For details of the actuator installation in a particular aircraft, reference should be made to the appropriate aircraft Air Publication.

22. When installing a new or reconditioned actuator, first check that it has not been damaged in transit or storage. Check that all external screws, nuts and bolts are fully tightened and that the correct front eye-end is fitted to the plunger. Check that the

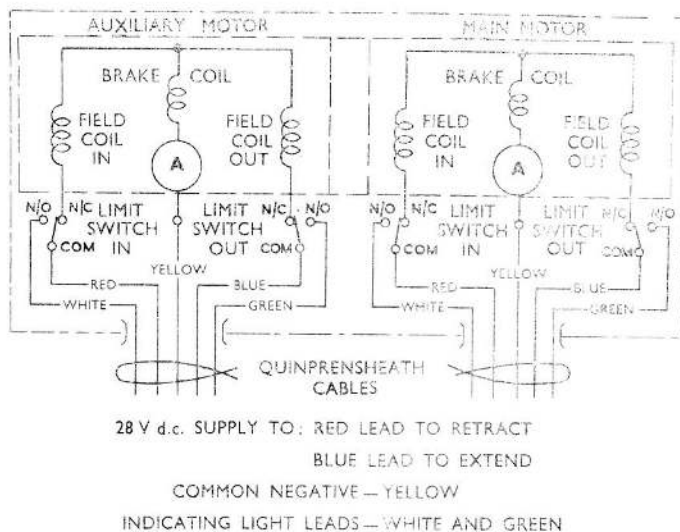

Fig. 5. Circuit diagram

RESTRICTED

extended and retracted dimensions of the plunger are correct for the installation.

23. Ensure that the actuator and its associated component are at the correct end of their travel before coupling them together.

24. After installation, operate the actuator in each direction with the main motor and the auxiliary motor in turn to prove correct functioning. Ensure that the limits of plunger travel are controlled by the actuator limit switches and not by any mechanical stops in the associated component.

SERVICING

25. These actuators should be serviced in accordance with the general chapter in A.P. 4343, Vol. 1, Sect. 17, Chap. 2 and the instructions contained in the relevant Servicing Schedule.

Lubrication

26. As these actuators are lubricated during manufacture or overhaul, they should not require internal re-lubrication between overhauls. External fittings should be kept well lubricated with a low-temperature grease.

Testing

27. If the serviceability of an actuator is suspect apply the standard serviceability test detailed in the appropriate appendix to this chapter. If the actuator fails to meet the requirements of its standard serviceability test it should be disposed of in accordance with the current service instruction.

Appendix A

STANDARD SERVICEABILITY TEST FOR ACTUATOR, PLESSEY, TYPE ICZ80383/1

Introduction

1. When considered necessary the tests detailed in this appendix are to be applied to the above-mentioned actuator immediately prior to installation in an aircraft, or when its serviceability is suspect.

Test equipment

2. The following test equipment is required:—

Linear actuator test rig (Ref. No. 4 G/5420)

250V insulation resistance tester, Type C (Ref. No. 5G/152)

A 29V d.c. supply

Tension gauge (Ref. No. 1 H/59)

TEST PROCEDURE

Insulation resistance test

3. Using the insulation resistance tester, check the resistance between each lead and the actuator body in turn. The reading in each instance must not be less than 500,000 ohms.

Brush gear

4. To gain access to the brushes:—

(1) Slacken the locknut and remove the front eye end and locknut from the end of the plunger.

(2) Remove the four nuts, covers and bushes from the cable entry glands in the front of the outer cover.

(3) Remove the six small screws and plain washers (four in the upper section of the rear cover and two in the lower flange of the centre housing) which secure the outer cover flange to the forward face of the centre housing. Unscrew the captive screw at the front of the outer cover and withdraw the outer cover from the actuator.

5. The length of the brushes should not be less than 0.25 in. and the brush spring pressure should be between 3.5 and 4.5 oz. (100 and 127 gm) when the brush projects $\frac{1}{2}$ in. from the holder.

Function test

6. The linear actuator test rig is described and illustrated in A.P.4343S, Vol. 1, Book 2, Sect. 8. Set the actuator to be tested on the rig and ensure that it operates within the limits given in Table 1.

7. Connect indicating lamps or magnetic indicators to the white and green leads of the main motor. Check that the lamp connected to the white lead lights when the actuator is fully retracted and the lamp connected to the green lead lights when the actuator is fully extended. Repeat this test using the auxiliary motor.

8. Perform several inching strokes in each direction to check for satisfactory brake operation.

RESTRICTED

TABLE 1

Applied voltage	Load	Time for 3 in. stroke (sec.)		Max. current (amp.)	Length of stroke (in.)
		Min.	Max.		
Main motor					
29	80 lb. T.L.A.	2.75	3.45	2.0	3.0 + 0.06
29	80 lb. T.L.O.	3.80	4.80	2.8	3.0 + 0.05
29	80 lb. C.L.O.	3.80	4.80	2.8	3.0 — 0.05
29	80 lb. C.L.A.	2.75	3.45	2.0	3.0 — 0.06
Auxiliary motor					
29	80 lb. T.L.A.	2.80	3.70	2.1	3.0 + 0.06
29	80 lb. T.L.O.	3.80	4.80	2.9	3.0 + 0.05
29	80 lb. C.L.O.	3.80	4.80	2.9	3.0 — 0.05
29	80 lb. C.L.A.	2.80	3.70	2.1	3.0 — 0.06

T.L.A. Tensile load assisting
T.L.O. Tensile load opposing
C.L.O. Compressive load opposing
C.L.A. Compressive load assisting

RESTRICTED

Appendix 1

ACTUATOR, PLESSEY, TYPE 1CZ80383/1

LEADING PARTICULARS

Actuator, Plessey, Type 1CZ 80383/1	Ref. No. 5W/2828
<i>Voltage (normal)</i>	28V d.c.
<i>(range)</i>	22—29V d.c.
<i>Working load (normal)</i>	80 lb
<i>(maximum)</i>	120 lb
<i>Maximum static load</i>	800 lb
<i>Ambient temperature range</i>	—50 to +100 deg. C.
<i>Maximum operating frequency</i>	10 cycles per hour
<i>Weight</i>	5.25 lb
<i>Stroke (normal load and voltage)</i>	3 in. + 0.02 in.
<i>Retracted centres</i>	3.89 in. — 0.03 in.
<i>Extended centres</i>	6.89 in. + 0.03 in.
<i>Motors:</i>					
<i>Type (main and auxiliary)</i>	C1606H/41
<i>Nominal output</i>	0.03 h.p. at 15000 rev/min
<i>Rating (full load)</i>	1.5 minutes

This actuator is the typical model described and illustrated in the main chapter. It is mounted in the aircraft by two trunnions which form an integral part of the U-shaped trunnion assembly secured to the rear cover.

RESTRICTED

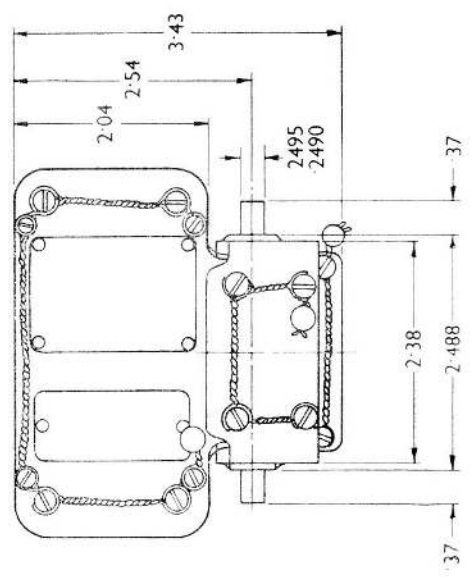
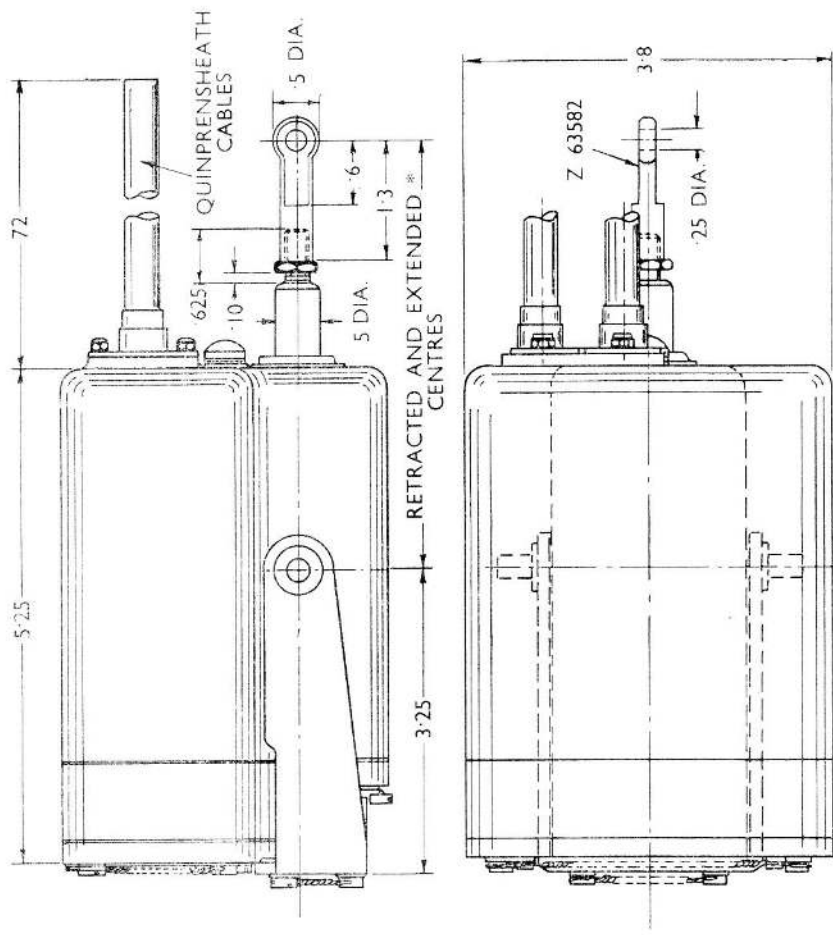

ALL DIMENSIONS IN INCHES

* SEE LEADING PARTICULARS

Fig. 1. Installation drawing

RESTRICTED

This file was downloaded
from the RTFM Library.

Link: www.scottbouch.com/rtfm

Please see site for usage terms,
and more aircraft documents.

