

## Chapter 1

## ACTUATORS, ROTAX, C5000 SERIES

## LIST OF CONTENTS

	Para.		Para.
<i>Introduction</i> ... ..	1	<b>Installation</b> ... ..	12
<b>Description</b> ... ..	2	<b>Servicing</b> ... ..	14
<i>Motor</i> ... ..	3	<i>Brushgear</i> ... ..	15
<i>Gear train</i> ... ..	5	<i>Lubrication</i> ... ..	16
<i>Switch housing</i> ... ..	6	<i>Commutator</i> ... ..	17
<i>Adapter housing</i> ... ..	9	<i>General</i> ... ..	18
<b>Operation</b> ... ..	10	<b>Testing</b> ... ..	20

## LIST OF ILLUSTRATIONS

	Fig.
<i>Actuator, Type C5001/2, shown in section</i> ... ..	1
<i>Arrangement of switch block</i> ... ..	2
<i>Angular movement positions</i> ... ..	3

## LIST OF APPENDICES

	App.		App.
<i>Standard serviceability test for actuators, Rotax, C5000 series</i> ... ..	A	<i>Actuator, Rotax, Type C5025</i> ... ..	9
<i>Actuator, Rotax, Type C5001/2</i> ... ..	1	<i>Actuator, Rotax, Type C5027</i> ... ..	10
<i>Actuator, Rotax, Type C5005/2</i> ... ..	2	<i>Actuator, Rotax, Type C5029</i> ... ..	11
<i>Actuator, Rotax, Type C5006/2</i> ... ..	3	<i>Actuator, Rotax, Type C5035</i> ... ..	13
<i>Actuator, Rotax, Type C5007/2</i> ... ..	4	<i>Actuator, Rotax, Type C5041</i> ... ..	13
<i>Actuator, Rotax, Type C5009/2</i> ... ..	5	<i>Actuator, Rotax, Type C5048</i> ... ..	14
<i>Actuator, Rotax, Type C5017/2</i> ... ..	6	<i>Actuator, Rotax, Type C5050</i> ... ..	15
<i>Actuator, Rotax, Type C5021/2</i> ... ..	7	<i>Actuator, Rotax, Type C5052</i> ... ..	16
<i>Actuator, Rotax, Type C5022/2</i> ... ..	8	<i>Actuator, Rotax, Type C5053</i> ... ..	17
		<i>Actuator, Rotax, Type C5058</i> ... ..	18

RESTRICTED

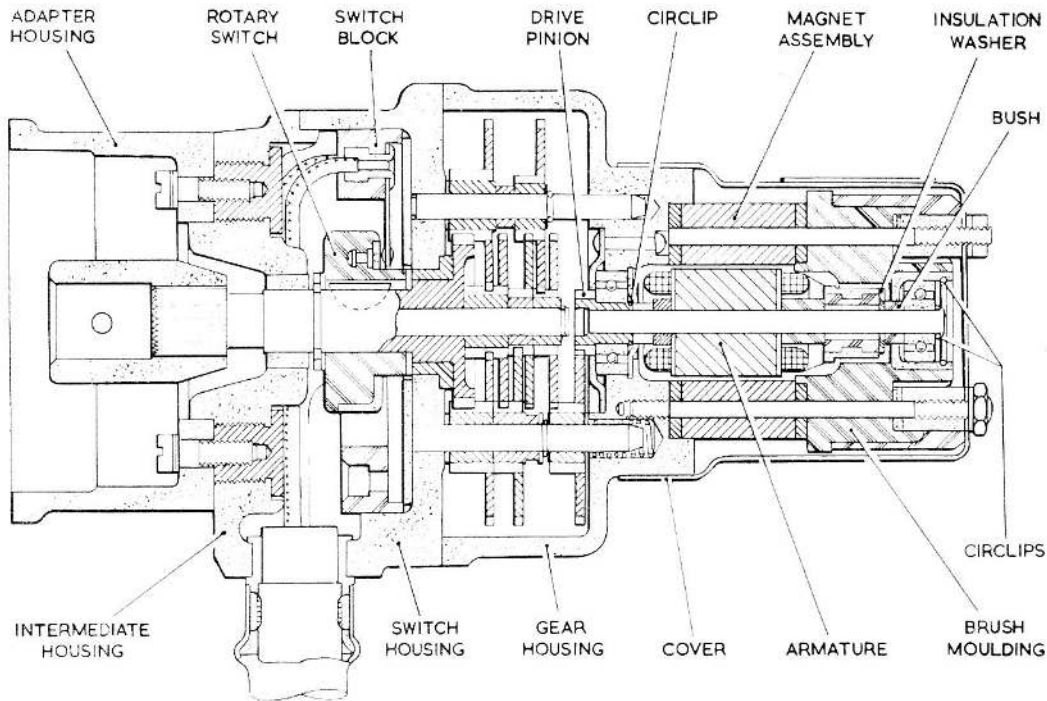

**Fig. 1. Actuator, Type C5001/2, shown in section**

### Introduction

1. The Type C5000 series of rotary actuators has been developed for use on equipment where reversible rotary movement is required. The range covers a number of variations in mounting, type of connection, speed and torque output. Information which applies to specific types will be found in the appendices to this chapter and is additional to the information contained in the following paragraphs.

### DESCRIPTION

2. The construction of the C5000 series of rotary actuators is illustrated in fig. 1. This shows a Type C5001/2 actuator which is typical of the series, except that some do not embody the adapter housing and coupling piece.

### Motor

3. The motor operates on 28 volts and is a 2-pole permanent magnet machine. The

armature shaft is supported in two ball bearings—one at the commutator end is housed in the brush block, and one at the driving end is housed in the gear housing. A pinion on the driving end of the armature shaft transmits the drive to the gear train.

4. Electrical connection to the motor is made by two wires leading from the switch block to clips which fit over the top of each brush box. These clips also compress the brush springs to the necessary length for producing the correct brush pressure.

### Gear train

5. A train of reduction gears reduces the speed of the final drive shaft to very much less than the speed of the motor and the reduction ratio varies for the specific types. The gears are carried on three layshafts, two of which locate in the gear housing and switch housing, and the third between the armature pinion and the final drive shaft.

**RESTRICTED**

**Switch housing**

6. The switch housing provides location for two of the layshafts. Two semi-circular terminal blocks (fig. 2) provide the connecting points for external and internal electrical leads. The external electrical cable passes into the actuator through a cable outlet fitted in the circumference of the intermediate and switch housings.

7. The limit switch, where fitted, consists of contact arms fastened on to the four terminals on the terminal blocks, and a rotor secured to the final drive shaft. Two contact plates are inserted in the rotor, and the ends of the contact arms bear on the plates. The positions of the contact arms and plates, relative to one another, govern the amount and direction of rotation of the final drive shaft.

8. The intermediate housing fits in the end of the switch housing, completely enclosing the switch block.

**Adapter housing**

9. The adapter housing is fitted on some types and not on others. It is secured to

the end face of the intermediate housing and protects the drive coupling. The housings are fitted to accommodate special installation requirements and vary in shape and the position of the securing holes.

**OPERATION**

10. The actuator may be operated in a clockwise or anti-clockwise direction by reversing the flow of current in the armature of the motor. When current is fed through the brushes to the armature, the actuator operates in the direction of rotation selected by the appropriate switch, until it reaches a position where contact between the contact arm on the terminal block and the contact plate on the rotor is broken. At this point the limit switch makes connection with the other circuit which allows the actuator to rotate in the opposite direction upon operation of the switch.

11. The maximum amount of rotary movement is 90 degrees with a variation up to 2 degrees above 90. The various positions of angular movement are illustrated in fig. 3, which indicates the appropriate extent of travel for the different types of actuator. The machine may be stopped at any intermediate position and may be made to rotate in either direction.

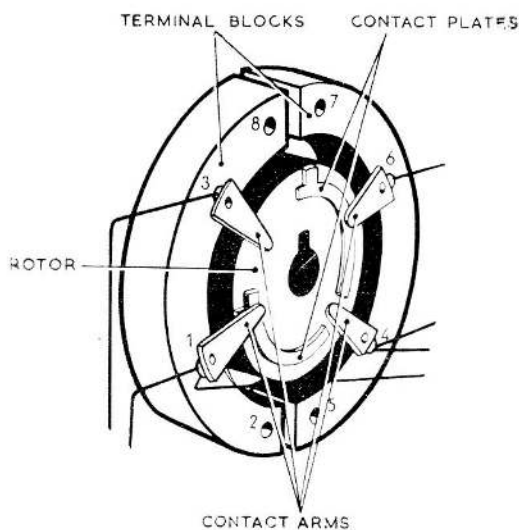

Fig. 2. Arrangement of switch block

**INSTALLATION**

12. Information on the installation of the actuators will be found in the relevant Air Publications for specific aircraft. It is important that care be exercised when making the electrical connections, as a reversal of leads will reverse the direction of rotation indicated in the relevant circuit diagram.

13. The actuators will operate satisfactorily in any position, but to obtain maximum operating efficiency they should be mounted vertically.

**SERVICING**

14. Servicing of an installed actuator is confined to general inspection to ensure the actuator has not sustained damage, and that it is secure on its mounting.

**RESTRICTED**

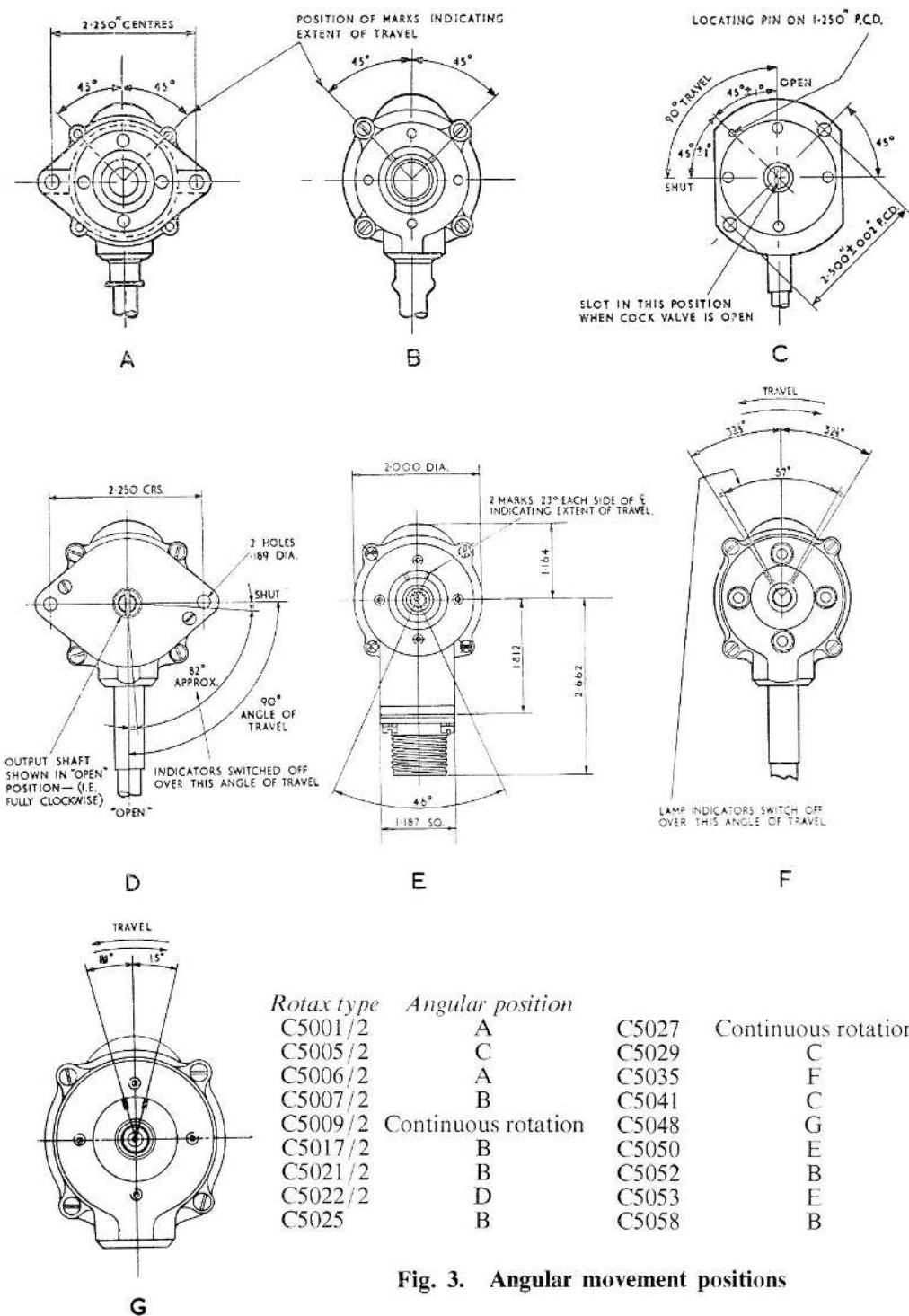

Rotax type	Angular position	
C5001/2	A	C5027 Continuous rotation
C5005/2	C	C5029 C
C5006/2	A	C5035 F
C5007/2	B	C5041 C
C5009/2	Continuous rotation	C5048 G
C5017/2	B	C5050 E
C5021/2	B	C5052 B
C5022/2	D	C5053 E
C5025	B	C5058 B

Fig. 3. Angular movement positions

**Brushgear**

**15.** The actuator should be removed from the aircraft and serviced at periods prescribed in the appropriate servicing schedule. Normal servicing will not necessitate any dismantling other than removing the motor cover and brush retaining ring to obtain access to the brush gear. The brushes should be removed, and checked for damage and wear, ensuring that they are a free, but not slack, fit in their holders. When the brushes are removed during servicing, or for any other reason, the length of each brush should be checked to ascertain that it will not wear down beyond its minimum length before the next servicing period. The minimum length of brushes is given in the leading particulars of the appendices.

**Lubrication**

**16.** The actuators are sufficiently lubricated during manufacture and should not need further attention, except during repair when grease XG-275 should be used.

**Commutator**

**17.** If the commutator is found to require skimming, it should be noted that the minimum permissible diameter is 0.335 in. After skimming, the slots between the commutator bars should be cleaned out.

**General**

**18.** Check the security of all soldered leads. Ensure that all external nuts, screws and locking devices are secure. Examine the electrical connections for security and damage, and the cable for frayed or damaged insulation.

**19.** At the end of the servicing operations, ensure that all components are in their correct positions, and replace and secure the motor cover.

**TESTING**

**20.** All the C5000 series of actuators should be tested for satisfactory operation by connecting them to a suitable 28-volt circuit.

**21.** Since these actuators have permanent magnetic field motors, it is preferable to use a pure d.c. supply when testing. If a d.c. supply is not available, however, it is permissible *for functional tests only*, to use an a.c. supply which has been rectified by a suitable rectifier unit, e.g., R.A.F. Type 37 (Ref. No. 5P/2908) or Admiralty Type "Westruk 609" and "Westruk 829".

**Note . . .**

*When "testing to specification", pure d.c. only must be used.*

**22.** It is important to ensure that the supply polarity is correct, since with a reversal of polarity it is possible for the switch cam to overrun the switch contacts in the opposite direction to that required to operate the unit correctly, thus leaving the electrical system in an open-circuited condition.

**23.** Test the insulation of all live parts to the frame by a 250-volt insulation resistance tester. A reading of not less than 0.05 megohm should be obtained.

## Appendix A

### STANDARD SERVICEABILITY TEST FOR ACTUATORS, ROTAX, C5000 SERIES

#### Introduction

1. The following tests may be applied to the actuator before it is put into service, or at any time when its serviceability is suspect.

#### Test equipment

2. The following test equipment is required:—

(1) Rotary actuator test rig (Ref. No. 4G/6591).

(2) Insulation resistance tester, Type C (Ref. No. 5G/152).

#### Testing

##### *Performance test*

3. Set the actuator on the test rig, and ensure that it operates within the limits given in Tables 1 and 2 respectively. The tests should be made for each direction of rotation, and at 28 volts.

**TABLE 1**

#### Tests on no load

Type	Angular travel (deg.)	Time of travel (sec.) (max.)	Current (amp.) (max.)
C5001/2	90	3.8	0.45
C5005/2	90	3.8	0.45
C5006/2	90	3.8	0.45
C5007/2	90	3.8	0.45
C5009/2	Continuous	4.0 r.p.m.	0.45
C5017/2	90	3.8	0.45
C5021/2	90	19.5	0.40
C5022/2	90	3.8	0.45
C5025	90	3.8	0.45
C5027	Continuous	4.0 r.p.m.	0.45
C5029	90	3.8	0.45
C5035	65	14.1	0.40
C5041	90	3.8	0.45
C5048	30	0.5	2.60
C5050	46	1.1	0.50
C5052	90	3.8	0.45
C5053	46	1.1	0.50
C5058	90	1.7	2.60

**RESTRICTED**

**TABLE 2**  
**Tests on normal load**

Type	Angular travel (deg.)	Normal load (lb. in.)	Time of travel (sec.) (max.)	Current (amp.) (max.)
C5001/2	90	30	4.3	0.65
C5005/2	90	30	4.3	0.65
C5006/2	90	30	4.3	0.65
C5007/2	90	30	4.3	0.65
C5009/2	Continuous	30	3.5 r.p.m.	0.65
C5017/2	90	30	4.3	0.65
C5021/2	90	30	21.4	0.60
C5022/2	90	30	4.3	0.65
C5025	90	30	4.3	0.65
C5027	Continuous	30	3.5 r.p.m.	0.65
C5029	90	30	4.3	0.65
C5035	65	30	15.5	0.60
C5041	90	30	4.3	0.65
C5048	30	30	0.6	3.00
C5050	46	13.5	1.3	0.70
C5052	90	30	4.3	0.65
C5053	46	13.5	1.3	0.70
C5058	90	30	1.9	3.00

4. The actuator must operate on 18 volts against a normal load.

with a 250-volt insulation resistance tester between all live parts and the frame, must not be less than 0.05 megohm.

*Insulation resistance test*

5. The insulation resistance, when measured

## Appendix 1

### ACTUATOR, ROTAX, TYPE C5001/2

#### LEADING PARTICULARS

<b>Actuator, Type C5001/2</b>	...	...	...	...	...	<b>Ref. No. 5W/1</b>
<i>Normal voltage</i>	...	...	...	...	...	28 volts
<i>Current consumption at 28V on normal load</i>	...	...	...	...	...	0.65 amp.
<i>Normal load</i>	...	...	...	...	...	30 lb. in.
<i>Maximum load</i>	...	...	...	...	...	55 lb. in.
<i>Angular travel</i>	...	...	...	...	...	90 deg.
<i>Time of travel on normal load</i>	...	...	...	...	...	4.3 sec. (max.)
<i>Temperature range</i>	...	...	...	...	...	-40 to +90 deg. C.
<i>Overall length</i>	...	...	...	...	...	4.766 in.
<i>Brush spring pressure at 0.172 in.</i>	...	...	...	...	...	1.25 oz.
<i>Brushes</i>	...	...	...	...	...	Grade E.G.14
<i>Minimum length of brush</i>	...	...	...	...	...	0.125 in.
<i>Reduction gearing ratio (8-stage)</i>	...	...	...	...	...	4,450 to 1
<i>Weight</i>	...	...	...	...	...	2 lb.

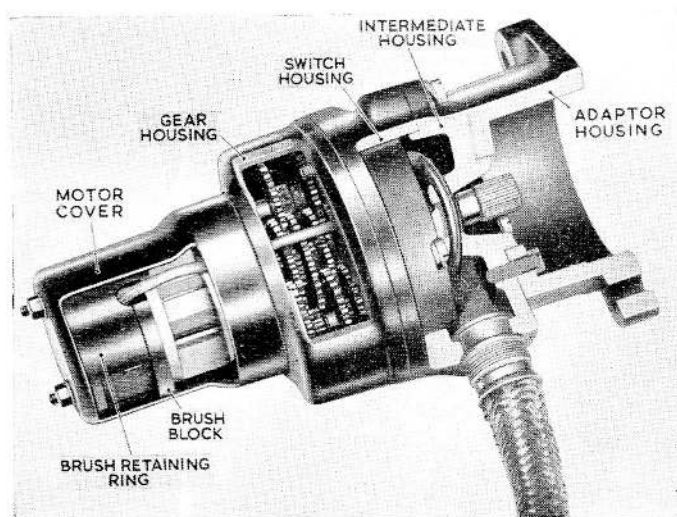

Fig. 1. Actuator, Type C5001/2

**RESTRICTED**

### Description

1. The C5001/2 rotary actuator is similar to that described in the main chapter. It has an adapter housing fitted over the splined drive coupling, the adapter housing being secured to the face of the switch housing (fig. 1). External electrical connection is made through a 10 ft. long lead of Quin-prenmet cable. The theoretical circuit diagram (fig. 2) shows the wiring connection for operation of the actuator, but details of particular installations should be obtained by reference to the relevant Aircraft Handbook.

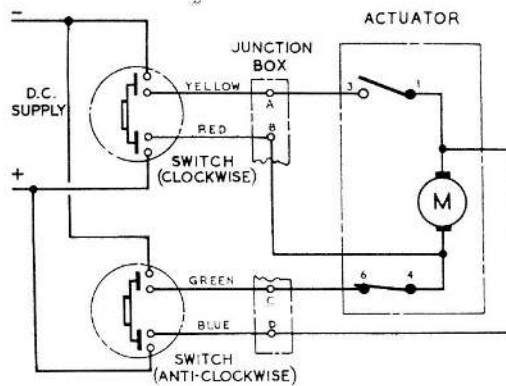

Fig. 2. Circuit diagram

**RESTRICTED**

## Appendix 2

### ACTUATOR, ROTAX, TYPE C5005/2

#### LEADING PARTICULARS

<b>Actuator, Type C5005/2</b>	...	...	...	...	...	<b>Ref. No. 5W/174</b>
<i>Normal voltage</i>	...	...	...	...	...	28 volts
<i>Current consumption at 28V on normal load</i>	...	...	...	...	...	0.65 amp.
<i>Normal load</i>	...	...	...	...	...	30 lb. in.
<i>Maximum load</i>	...	...	...	...	...	55 lb. in.
<i>Angular travel</i>	...	...	...	...	...	90 deg.
<i>Time of travel on normal load</i>	...	...	...	...	...	4.3 sec. (max.)
<i>Temperature range</i>	...	...	...	...	...	-40 to +90 deg. C.
<i>Overall length</i>	...	...	...	...	...	4.843 in.
<i>Brush spring pressure at 0.172 in.</i>	...	...	...	...	...	1.25 oz.
<i>Brushes</i>	...	...	...	...	...	Grade E.G.14
<i>Minimum length of brush</i>	...	...	...	...	...	0.125 in.
<i>Reduction gearing ratio (8-stage)</i>	...	...	...	...	...	4,450 to 1
<i>Weight</i>	...	...	...	...	...	1 lb. 4 oz.

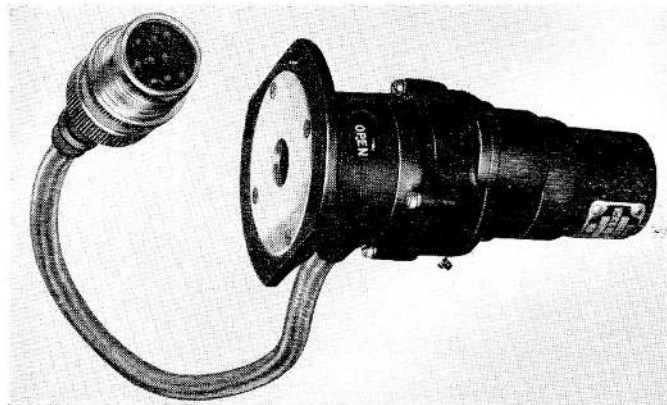

Fig. 1. Actuator, Type C5005/2

RESTRICTED

### Description

1. The C5005/2 rotary actuator is similar to that described in the main chapter. It has an adapter housing fitted over the splined drive coupling, the adapter housing being secured to the face of the switch housing (fig. 1). A flange at the extreme end of the adapter housing is recessed and a circular plate with a small bore in the centre (to allow coupling of the actuator) fits in the recess. A slot in the wall of the housing reveals an indicator which is marked SHUT and OPEN. This indicator is fixed to the driving shaft and rotates with it. Thus at one extreme position the word shut appears at the slot, and at the other extreme the word OPEN appears. These words refer to the positions of the equipment being operated by the actuator.

2. Electrical connection is made to the actuator by a 1 ft. long lead of petrol resisting cable with a socket (Ref. No. 5X/6039) at the end. The theoretical circuit diagram (fig. 2) illustrates the method of connecting the actuator to the electrical supply and other components, but reference should be made to the relevant Aircraft Handbook for information on installation of the actuator.

3. The limit switch is generally the same as for most of this series of actuators. The two terminals 2 and 5 (fig. 2) are used to connect two indicator lamps in the circuit. The lamps indicate the open and shut

positions of the equipment which is being operated by the actuator. Current is supplied to each lamp, and the limit switch is arranged so that one lamp circuit is completed when the actuator has reached its extreme point of travel in a clockwise direction, and the other lamp circuit is completed at the end of the anti-clockwise travel of the actuator.

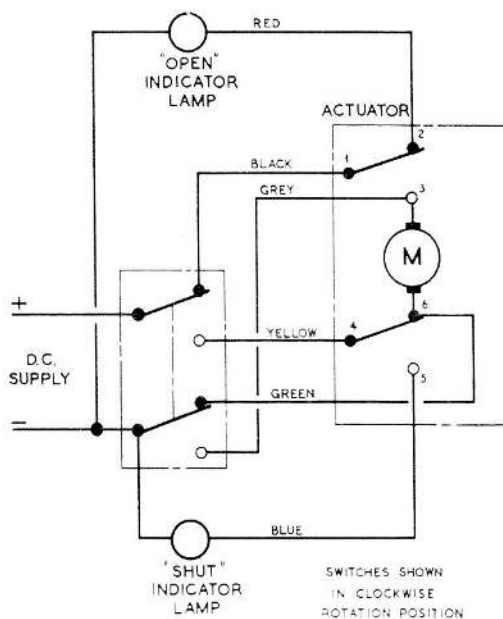

Fig. 2. Circuit diagram

### Appendix 3

## ACTUATOR, ROTAX, TYPE C5006/2

### LEADING PARTICULARS

<b>Actuator, Type C5006/2</b>	...	...	...	...	...	...	<b>Ref. No. 5W/</b>
<i>Normal voltage</i>	...	...	...	...	...	...	28 volts
<i>Current consumption at 28V on normal load</i>	...	...	...	...	...	...	0.65 amp.
<i>Normal load</i>	...	...	...	...	...	...	30 lb. in.
<i>Maximum load</i>	...	...	...	...	...	...	55 lb. in.
<i>Angular travel</i>	...	...	...	...	...	...	90 deg.
<i>Time of travel on normal load</i>	...	...	...	...	...	...	4.3 sec. (max.)
<i>Temperature range</i>	...	...	...	...	...	...	-40 to +90 deg. C.
<i>Overall length</i>	...	...	...	...	...	...	4.776 in.
<i>Brush spring pressure at 0.172 in.</i>	...	...	...	...	...	...	1.25 oz.
<i>Minimum brush length</i>	...	...	...	...	...	...	0.125 in.
<i>Reduction gearing ratio (8-stage)</i>	...	...	...	...	...	...	4,450 to 1
<i>Weight</i>	...	...	...	...	...	...	... 2 lb.

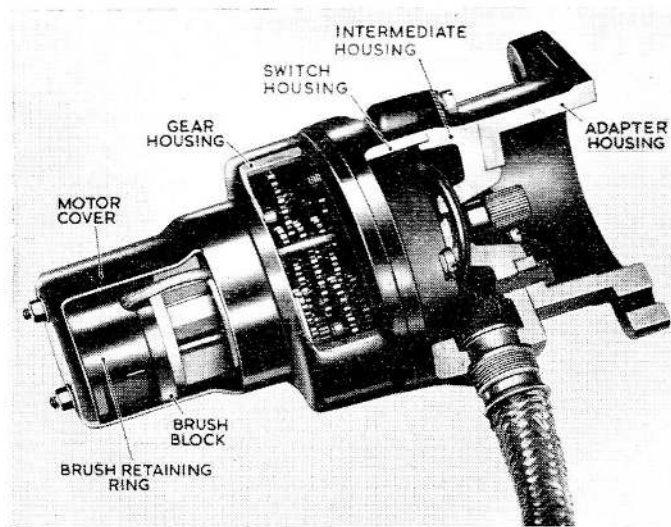
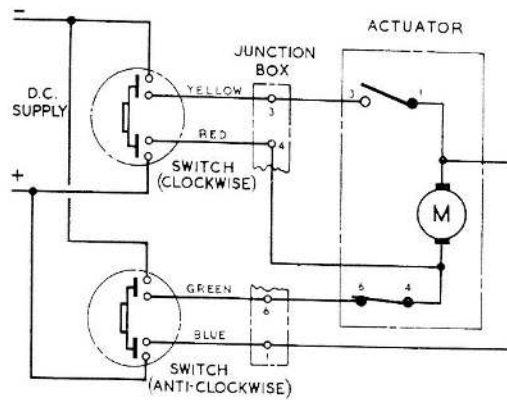

Fig. 1. Actuator, Type C5006/2

RESTRICTED

### Description

1. The C5006/2 actuator is similar to that described in the main chapter. It has an adapter housing fitted over the splined drive coupling, the adapter housing being secured to the face of the switch housing (fig. 1). External electrical connection is made by an 8 ft. length of Quinpremet cable, fitted with a 4-pole socket (Ref. No. 5X/6009). The theoretical circuit diagram (fig. 2) shows the wiring connections for operation of the actuator, but details of particular installations should be obtained by reference to the relevant Aircraft Handbook.



**Fig. 2. Circuit diagram**

## Appendix 4

### ACTUATOR, ROTAX, TYPE C5007/2

#### LEADING PARTICULARS

<b>Actuator, Type C5007/2</b> ... ..	<b>Ref. No. 5W/438</b>
<i>Normal voltage</i> ... ..	28 volts
<i>Current consumption at 28V on normal load</i> ... ..	0.65 amp.
<i>Normal load</i> ... ..	30 lb. in.
<i>Maximum load</i> ... ..	55 lb. in.
<i>Angular travel</i> ... ..	90 deg.
<i>Time of travel on normal load</i> ... ..	4.3 sec. (max.)
<i>Temperature range</i> ... ..	-40 to +90 deg. C.
<i>Overall length</i> ... ..	4.106 in.
<i>Brush spring pressure at 0.172 in.</i> ... ..	1.25 oz.
<i>Brushes</i> ... ..	Grade E.G.14
<i>Minimum brush length</i> ... ..	0.125 in.
<i>Reduction gearing ratio (8-stage)</i> ... ..	4,450 to 1
<i>Weight</i> ... ..	... 1 lb.

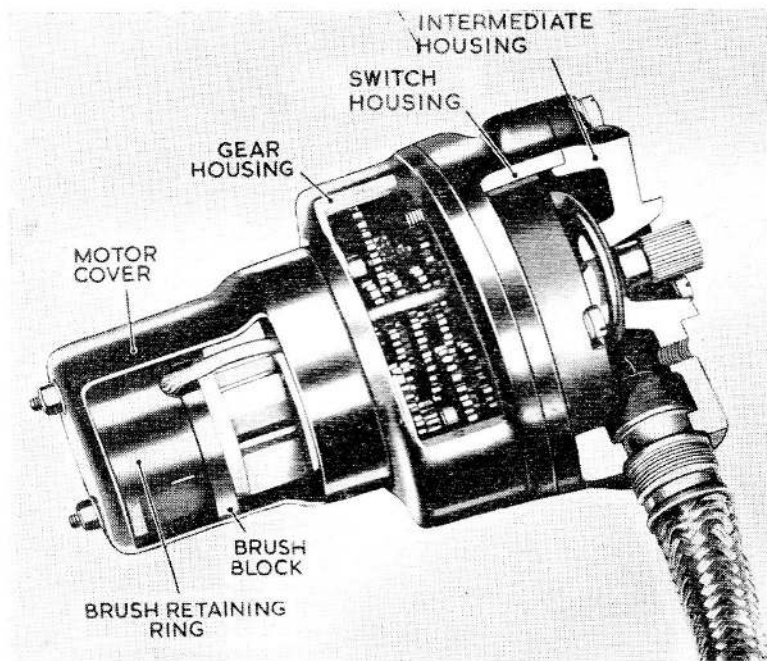
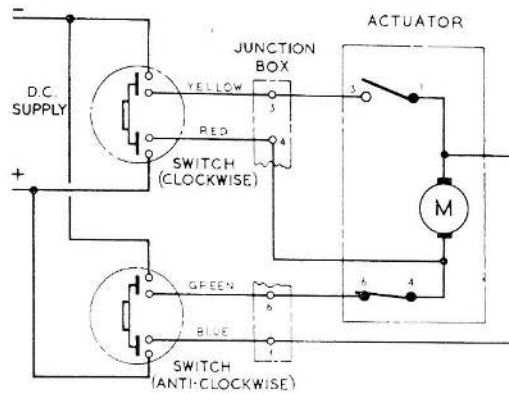

Fig. 1. Actuator, Type C5007/2

**RESTRICTED**

**Description**

1. The C5007/2 actuator is similar to that described in the main chapter. No adapter housing is fitted as the actuator is mounted directly on to the aircraft (fig. 1). A 10 ft. long lead of Quinpremet cable provides the external electrical connection for the actuator. The theoretical circuit diagram (fig. 2) illustrates the method of connecting the actuator to the electrical supply and other components, but reference should be made to the relevant Aircraft Handbook for information on installation of the actuator.



**Fig. 2. Circuit diagram**

## Appendix 5

### ACTUATOR, ROTAX, TYPE C5009/2

#### LEADING PARTICULARS

<b>Actuator, Type C5009/2</b> ... ..	<b>Ref. No. 5W/388</b>
<i>Normal voltage</i> ... ..	28 volts
<i>Current consumption at 28V on normal load</i> ... ..	0.65 amp.
<i>Normal load</i> ... ..	30 lb. in.
<i>Maximum load</i> ... ..	55 lb. in.
<i>Speed of travel on normal load</i> ... ..	3.5 r.p.m.
<i>Temperature range</i> ... ..	- 40 to +90 deg. C.
<i>Overall length</i> ... ..	4.025 in.
<i>Brush spring pressure at 0.172 in.</i> ... ..	1.25 oz.
<i>Brushes</i> ... ..	Grade E.G.14
<i>Minimum brush length</i> ... ..	0.125 in.
<i>Reduction gearing ratio (8-stage)</i> ... ..	4,450 to 1
<i>Weight</i> ... ..	1 lb.

#### Description

1. The C5009/2 actuator is similar to that described in the main chapter, except that no limit switches or adapter housing are fitted. External electrical connection is made by a 1 ft. length of Duprenmet 6 cable which

is attached to the actuator terminals. The rotation is clockwise (looking on the drive end), when the circuit is arranged such that the red lead is switched to positive (*fig. 1*), but reference should be made to the relevant Aircraft Handbook for information on particular installations of the actuator.

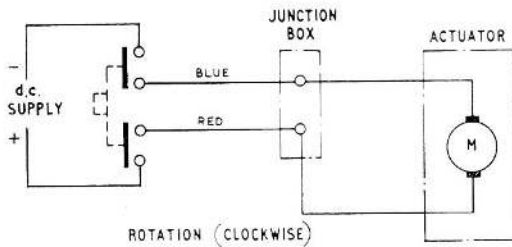

**Fig. 1. Circuit diagram**

**RESTRICTED**



## Appendix 7

### ACTUATOR, ROTAX, TYPE C5021/2

#### LEADING PARTICULARS

<b>Actuator, Type C5021/2</b>	...	...	...	...	...	<b>Ref. No. 5W/310</b>
<i>Normal voltage</i>	...	...	...	...	...	28 volts
<i>Current consumption at 28V on normal load</i>	...	...	...	...	...	0.60 amp.
<i>Normal load</i>	...	...	...	...	...	30 lb. in.
<i>Maximum load</i>	...	...	...	...	...	55 lb. in.
<i>Angular travel</i>	...	...	...	...	...	90 deg.
<i>Time of travel on normal load</i>	...	...	...	...	...	21.4 sec. (max.)
<i>Brush spring pressure at 0.172 in.</i>	...	...	...	...	...	1.25 oz.
<i>Brushes</i>	...	...	...	...	...	Grade E.G.14
<i>Minimum brush length</i>	...	...	...	...	...	0.125 in.
<i>Reduction gearing ratio (10-stage)</i>	...	...	...	...	...	21,006 to 1
<i>Weight</i>	...	...	...	...	...	19 oz.

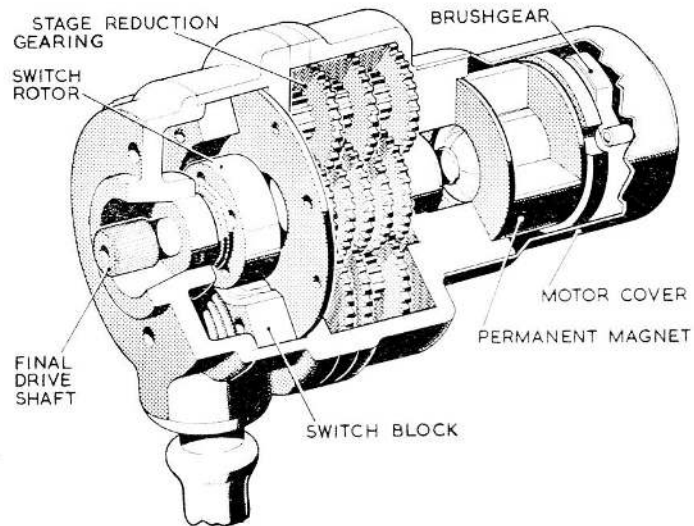
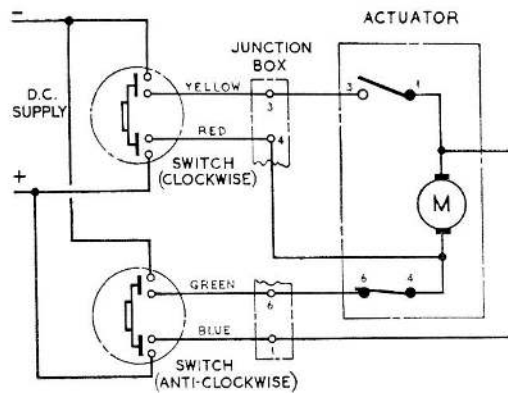

Fig. 1. Actuator, Type C5021/2

**RESTRICTED**

## Description

1. The C5021/2 actuator is similar to that described in the main chapter. No adapter housing is fitted as the actuator is intended for mounting direct on to the driven component (*fig. 1*). The reduction gearing consists of 10 stages, instead of 8, to produce the high reduction ratio. External electrical connection is made by a 5 ft. length of Quinpremet cable which is attached to the actuator terminals. The theoretical circuit diagram (*fig. 2*) illustrates the method of connecting the actuator to the electrical supply. For details of particular installations, reference should be made to the relevant Aircraft Handbook.



**Fig. 2. Circuit diagram**

## Appendix 8

### ACTUATOR, ROTAX, TYPE C5022/2

#### LEADING PARTICULARS

<b>Actuator, Type C5022/2</b> ... ..	<b>Ref. No. 5W/350</b>
<i>Operating voltage range</i> ... ..	18 - 29V d.c.
<i>Normal voltage</i> ... ..	28V d.c.
<i>Current consumption at 28V on normal load</i> ... ..	0.65 amp.
<i>Normal load</i> ... ..	30 lb. in.
<i>Maximum load</i> ... ..	55 lb. in.
<i>Maximum static load</i> ... ..	90 lb. in.
<i>Angular travel</i> ... ..	90 deg.
<i>Angular variation of stop positions</i> ... ..	$\pm 1\frac{1}{2}$ deg.
<i>Time of travel (normal load)</i> ... ..	4.3 sec. (max.)
<i>Ambient temperature range</i> ... ..	-40 deg. C to +90 deg. C
<i>Brush spring pressure at 0.172 in.</i> ... ..	1.25 oz.
<i>New brush length</i> ... ..	0.199 in. to 0.214 in.
<i>Minimum permissible brush length</i> ... ..	0.125 in.
<i>New commutator diameter</i> ... ..	0.350 in. to 0.352 in.
<i>Minimum commutator diameter</i> ... ..	0.335 in.
<i>Overall length</i> ... ..	4.504 in. (max.)
<i>Reduction gearing ratio (8-stage)</i> ... ..	4,450 : 1
<i>Weight</i> ... ..	1 lb. 4 oz.

1. The C5022/2 rotary actuator is similar to the C5005/2 actuator in having a visual indicator fitted and external lamp indication for the OPEN and SHUT positions of the equipment which is being operated by the actuator (fig. 1).

2. A modified adapter housing has been introduced to the C5022/2 unit, and the installation details for this, together with the angular travel for the OPEN and SHUT positions of the visual indicator, will be found in fig. 2 of this appendix.

3. Electrical connection is made to the actuator by a 1 ft. long lead of petrol-resisting cable with a socket 2CZ111698 (Ref. No. 5X/6379B) at the end.

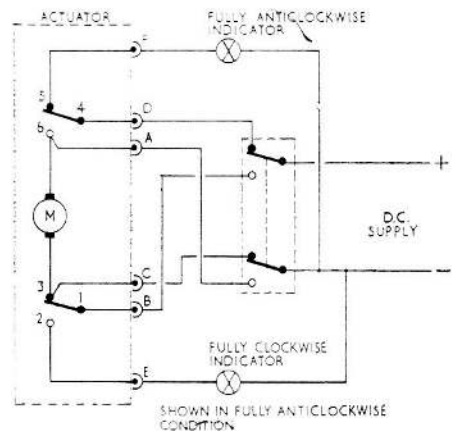
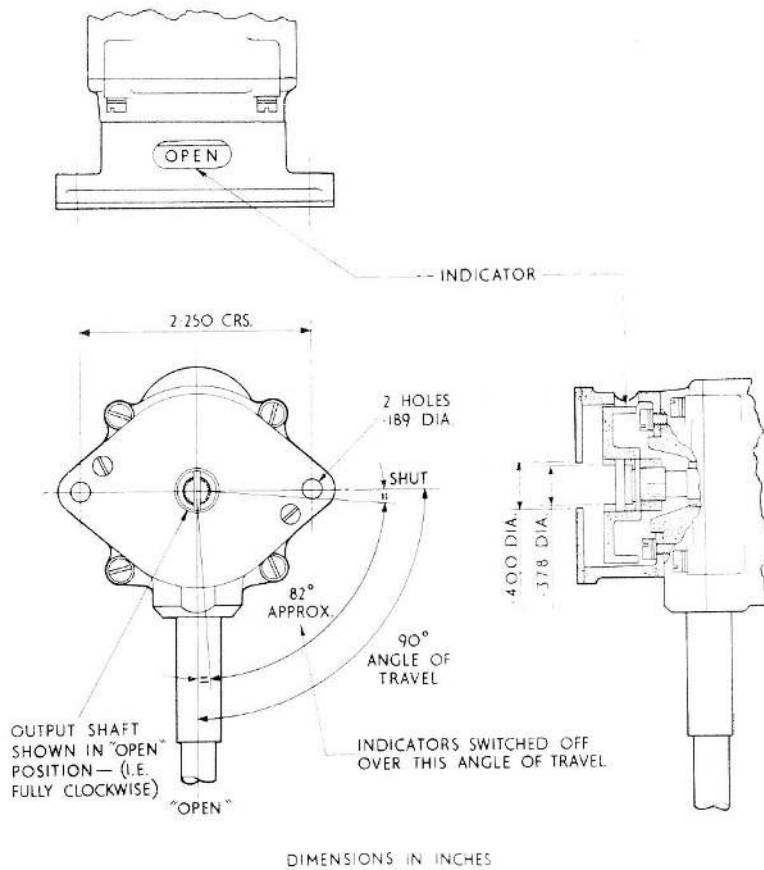

Fig. 1. Circuit diagram

**RESTRICTED**



**Fig. 2. Installation details**

**RESTRICTED**

## Appendix 9

### ACTUATOR, ROTAX, TYPE C5025

#### LEADING PARTICULARS

<b>Actuator, Type C5025</b> ... ..	<b>Ref. No. 5W/2593</b>
<i>Normal voltage</i> ... ..	28 volts d.c.
<i>Operating voltage range</i> ... ..	18 to 29 volts d.c.
<i>Current consumption at 28V on normal load</i> ... ..	0.65 amp.
<i>Normal load</i> ... ..	30 lb. in.
<i>Maximum load</i> ... ..	55 lb. in.
<i>Angular travel</i> ... ..	90 deg.
<i>Angular variation of stop positions</i> ... ..	$\pm 1\frac{1}{2}$ deg.
<i>Time of travel on normal load</i> ... ..	4.3 sec. (max.)
<i>Ambient temperature range</i> ... ..	-60 deg. C. to +90 deg. C.
<i>Overall length</i> ... ..	4.140 in.
<i>Electrical connection</i> ... ..	10 ft. of Quadramet 4 cable
<i>Brush spring pressure (compressed to 0.172 in.)</i> ... ..	1.25 oz. (35 gm.)
<i>Brushes</i> ... ..	Grade E.G.14
<i>Min. length of brush</i> ... ..	0.125 in.
<i>Gear ratio (8-stage)</i> ... ..	4,450 : 1
<i>Weight</i> ... ..	1 lb. 13 oz.

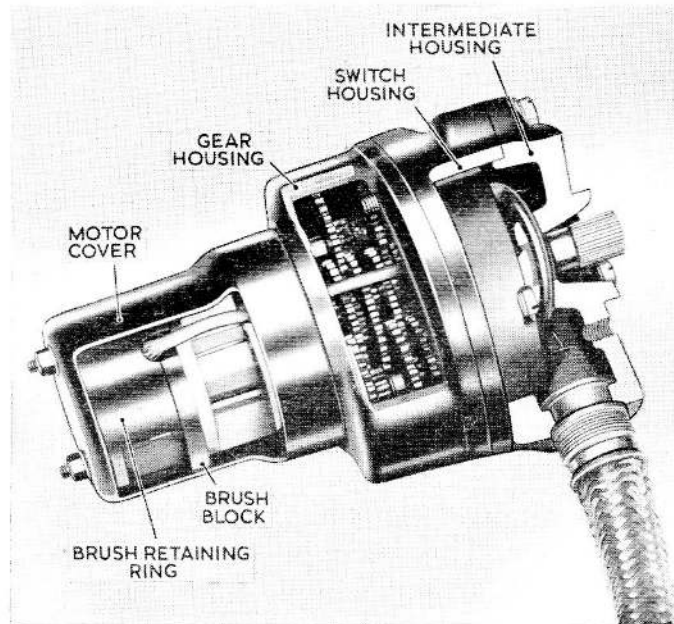

Fig. 1. Actuator, Type C5025

RESTRICTED

1. The C5025 rotary actuator (*fig.1*) is similar to others in the C5000 series, shims being fitted to give a greater end float on the armature shaft, gear shafts and output shaft.

2. The theoretical circuit diagram (*fig.2*) illustrates the method of connecting the actuator to the electrical supply and other components, but reference should be made to the relevant Aircraft Handbook for information of the actuator.

3. Four fixing holes tapped 6 B.A.  $\times$  0.218 in. deep, on a  $1.250 \pm 0.002$  in. P.C.D., are provided in the intermediate housing at the drive end of the unit, for mounting purposes.

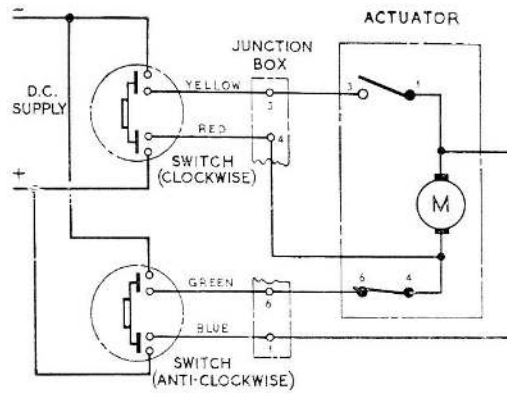

**Fig. 2. Circuit diagram**

## Appendix 10

### ACTUATOR, ROTAX, TYPE C5027

#### LEADING PARTICULARS

<b>Actuator, Type C5027</b> ... ..	<b>Ref. No. 5W/1346</b>
<i>Normal voltage</i> ... ..	28 volts
<i>Current consumption at 28V on normal load</i> ... ..	0.65 amp.
<i>Normal load</i> ... ..	30 lb. in.
<i>Maximum load</i> ... ..	55 lb. in.
<i>Speed of travel on normal load</i> ... ..	3.5 r.p.m.
<i>Temperature range</i> ... ..	- 60 to +90 deg. C.
<i>Brushes</i> ... ..	Grade E.G.14
<i>Brush spring pressure at 0.172 in.</i> ... ..	1.25 oz.
<i>Minimum brush length</i> ... ..	0.125 in.
<i>Reduction gearing ratio (8-stage)</i> ... ..	4,450 to 1
<i>Weight</i> ... ..	1 lb.

#### Description

1. The C5027 actuator is similar to that described in the main chapter except that no limit switches or adapter housing are fitted. External electrical connection is made by 18 in. length of Duprenmet 6 cable. The rota-

tion is clockwise (looking on the driving end), when the circuit is arranged such that the read lead is switched to positive (fig. 1), but for particular installations, reference should be made to the relevant Aircraft Handbook.

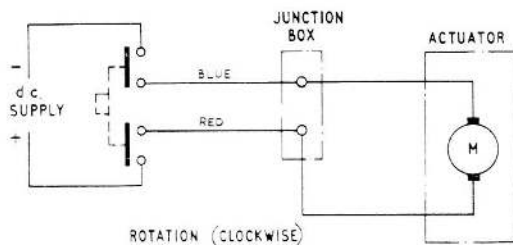

Fig. 1. Circuit diagram

**RESTRICTED**

## Appendix 11

### ACTUATOR, ROTAX, TYPE C5029

#### LEADING PARTICULARS

<b>Actuator, Type C5029</b> ... ..	<b>Ref. No. 5W/2563</b>
Normal voltage ... ..	28V d.c.
Operating voltage range ... ..	18 to 29V d.c.
Current consumption at 28V on normal load ... ..	0.65 amp.
Time of travel on normal load ... ..	4.3 sec. (max.)
Normal load ... ..	30 lb. in.
Maximum load ... ..	55 lb. in.
Angular travel ... ..	90 deg.
Angular variation of stop positions ... ..	$\pm 1\frac{1}{2}$ deg.
Ambient temperature ... ..	- 75 deg. C. to +90 deg. C.
Gear ratio (8-stage) ... ..	4,450 : 1
Brush spring pressure ... ..	1.25 oz. $\pm$ 10 per cent (at 0.172 in. dimension)
Brush length (new) ... ..	0.199 - 0.214 in.
Brush length (minimum permissible) ... ..	0.125 in.
Commutator diameter (new) ... ..	0.350 - 0.352 in.
Commutator diameter (minimum permissible) ... ..	0.335 in.
Weight (with cable) ... ..	1 lb. 8 oz.
Overall length ... ..	4.140 in.
Electrical connection ... ..	21 in. of petrol-resistant cable with socket 5X/6379B(2CZ111698).

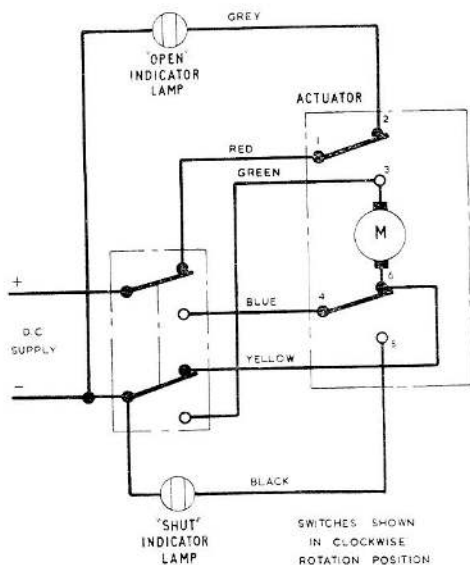

**Fig. 1. Circuit diagram**

1. The C5029 rotary actuator is similar to others in the C5000 series; provision is made for external indicating lamps in the clockwise and anti-clockwise positions (*fig. 1*). No adapter housing is fitted as the unit is mounted direct to the associated driven unit.

2. Four fixing holes tapped 4 B.A.  $\times$  0.218 in. deep on a  $1.250 \pm 0.002$  in. P.C.D. are provided in the intermediate housing at the drive end of the unit for mounting purposes.

3. For information on a particular installation reference should be made to the relevant Aircraft Handbook.

**RESTRICTED**

## Appendix 12

### ACTUATOR, ROTAX, TYPE C5035

#### LEADING PARTICULARS

<b>Actuator, Type C5035</b> ... ..	<b>Ref. No. 5W/2314</b>
<i>Operating voltage range</i> ... ..	18 - 29V d.c.
<i>Current consumption at 28V on normal load</i> ... ..	0.60 amp.
<i>Normal voltage</i> ... ..	28V d.c.
<i>Normal load</i> ... ..	30 lb. in.
<i>Maximum load</i> ... ..	55 lb. in.
<i>Maximum static load</i> ... ..	90 lb. in.
<i>Angular travel</i> ... ..	65 deg.
<i>Angular variation of stop positions</i> ... ..	± 1½ deg.
<i>Time of travel (normal load)</i> ... ..	15.5 sec. (max.)
<i>Ambient temperature range</i> ... ..	- 75 deg. C. to + 90 deg. C.
<i>Brush spring pressure (at 0.172 in.)</i> ... ..	1.25 oz.
<i>New brush length</i> ... ..	0.199 in. to 0.214 in.
<i>Minimum permissible brush length</i> ... ..	0.125 in.
<i>New commutator diameter</i> ... ..	0.350 in. to 0.352 in.
<i>Minimum permissible commutator diameter</i> ... ..	0.335 in.
<i>Overall length (over output shaft)</i> ... ..	4.113 in.
<i>Reduction gear ratio (10-stage)</i> ... ..	21,006 : 1
<i>Weight</i> ... ..	1½ lb. (with leads)

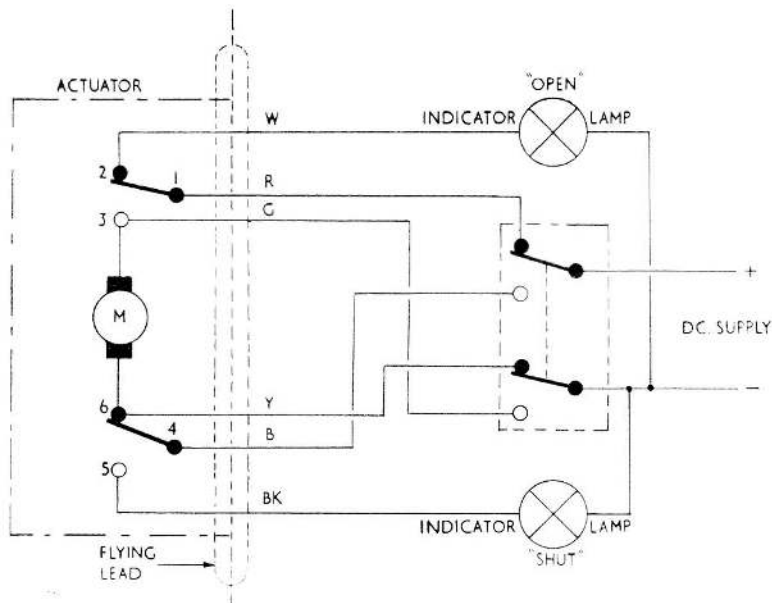

Fig. 1. Circuit diagram

RESTRICTED

1. The C5035 actuator is similar to others in the series; the angular travel of the output shaft is 65 deg., and extremes of clockwise and anti-clockwise travel are indicated by sawcuts in the output shaft and on the end face of the mounting spigot (fig. 2).

2. External indicator lamp contacts for the

OPEN and SHUT positions of the equipment which is being operated by the actuator is given in the circuit diagram (fig. 1).

3. Electrical connection to the actuator is by a 5 ft. flying lead of Septoprensheath 6 cable. For connections to the associated equipment reference should be made to fig. 1.

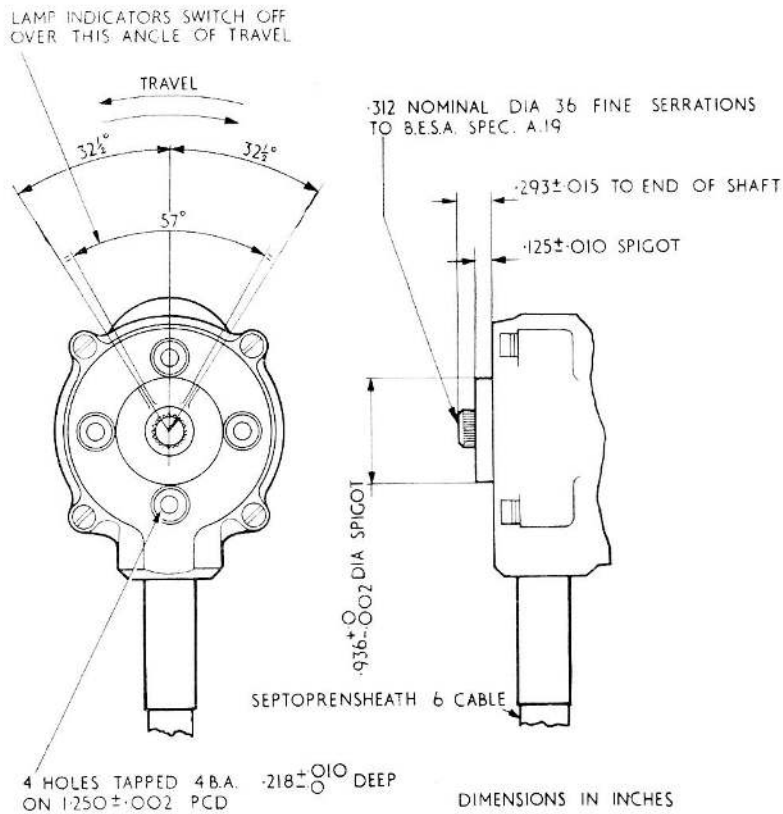

Fig. 2. Installation details

RESTRICTED

## Appendix 13

### ACTUATOR, ROTAX, TYPE C5041

#### LEADING PARTICULARS

<b>Actuator, Type C5041</b> ... ..	<b>Ref. No. 5W/4162</b>
Normal voltage ... ..	24V d.c.
Operating voltage range ... ..	18 to 29V d.c.
Current consumption at 28V on normal load ... ..	0.65 amp.
Time of travel on normal load ... ..	4.3 sec. (max.)
Normal load ... ..	30 lb. in.
Maximum load ... ..	55 lb. in.
Angular travel ... ..	90 deg.
Angular variation of stop positions ... ..	± 2 deg.
Ambient temperature ... ..	- 60 deg. C. to + 90 deg. C.
Gear ratio (8-stage) ... ..	4,450 : 1
Brush spring pressure ... ..	1.25 oz. ± 10 per cent (at 0.172 in. dimension)
Brush length (new) ... ..	0.199 - 0.214 in.
Brush length (minimum permissible) ... ..	0.125 in.
Commutator diameter (new) ... ..	0.350 - 0.352 in.
Commutator diameter (minimum permissible) ... ..	0.335 in.
Weight ... ..	1 lb. 4 oz.
Overall length ... ..	4.990 in. (max.)
Electrical connection ... ..	36 in. of Quintonyprensheath cable; connecting socket not provided.

1. The C5041 rotary actuator is similar to others in the C5000 series; provision is made for an external indicating lamp connection for clockwise rotation only (fig. 1).

2. An adapter housing is secured to the end face and located on the spigot of the intermediate housing; this encloses the serrated coupling and indicator moulding fitted to the output shaft.

3. Two holes 0.257 in. ± 0.003 in. diameter ± 0.000 on a 2.500 in. ± 0.002 in. P.C.D. are provided in the flange of the adapter housing at the mounting end, with a central locating hole 0.564 in. ± 0.001 in. diameter for fitting to the associated equipment.

4. An aperture is provided in the wall of the housing for observing the OPEN and SHUT positions engraved on the indicator moulding which occur at the extreme clockwise and anti-clockwise positions of the output shaft.

5. For information on a particular installation reference should be made to the relevant Aircraft Handbook.

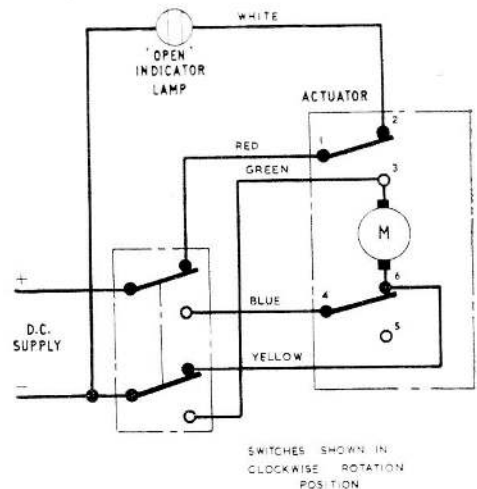

Fig. 1. Circuit diagram

**RESTRICTED**

## Appendix 14

### ACTUATOR, ROTAX, TYPE C5048

#### LEADING PARTICULARS

<b>Actuator, Type C5048</b> ... ..	<b>Ref. No. 5W/</b>
<i>Operating voltage range</i> ... ..	18V - 29V
<i>Current consumption at 28V on normal load</i> ... ..	3 amp.
<i>Normal voltage</i> ... ..	28V
<i>Normal load</i> ... ..	30 lb. in.
<i>Maximum load</i> ... ..	55 lb. in.
<i>Maximum static load</i> ... ..	90 lb. in.
<i>Angular travel</i> ... ..	30 deg.
<i>Angular variation of stop positions</i> ... ..	± 2 deg.
<i>Time of travel on normal load</i> ... ..	0.63 sec. (max.)
<i>Ambient temperature range</i> ... ..	-40 deg. C. to +185 deg. C.
<i>Brush spring pressure at 0.172 in.</i> ... ..	1.25 oz.
<i>Brush length (new)</i> ... ..	0.199 in. to 0.214 in.
<i>Brush length (minimum)</i> ... ..	0.125 in.
<i>Commutator dia. (new)</i> ... ..	0.351 in.
<i>Commutator dia. (minimum)</i> ... ..	0.335 in.
<i>Reduction gearing ratio (8-stage)</i> ... ..	4,450 : 1
<i>Length</i> ... ..	4.110 in.
<i>Weight</i> ... ..	1 lb. 4 oz.

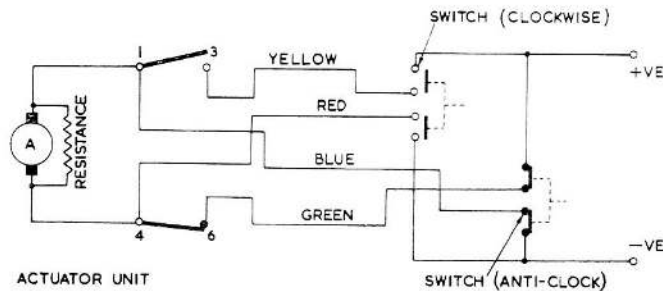

**Fig. 1. Circuit diagram**

1. The C5048 actuator is similar to the one described in the main chapter but has been designed to operate at a higher temperature, and has been sealed against ingress of water. No adapter housing is fitted; four holes tapped 4 B.A.  $\times$  0.218 in. deep on a 1.250 P.C.D. are provided in the intermediate housing at the drive end of the unit for mounting purposes.

2. To restrict overrun, a dynamic brake has been incorporated in this actuator and forms part of the brush retaining ring.

3. Electrical connections are made by approximately 9 in. of Uni-efglas 20 cable and connected externally as shown in the circuit diagram (fig. 1).

4. Information given in the main chapter regarding installation and servicing is applicable to this actuator. For details of installation in a particular aircraft, reference must be made to the relevant Aircraft Handbook. An installation diagram is shown in fig. 2.

**RESTRICTED**

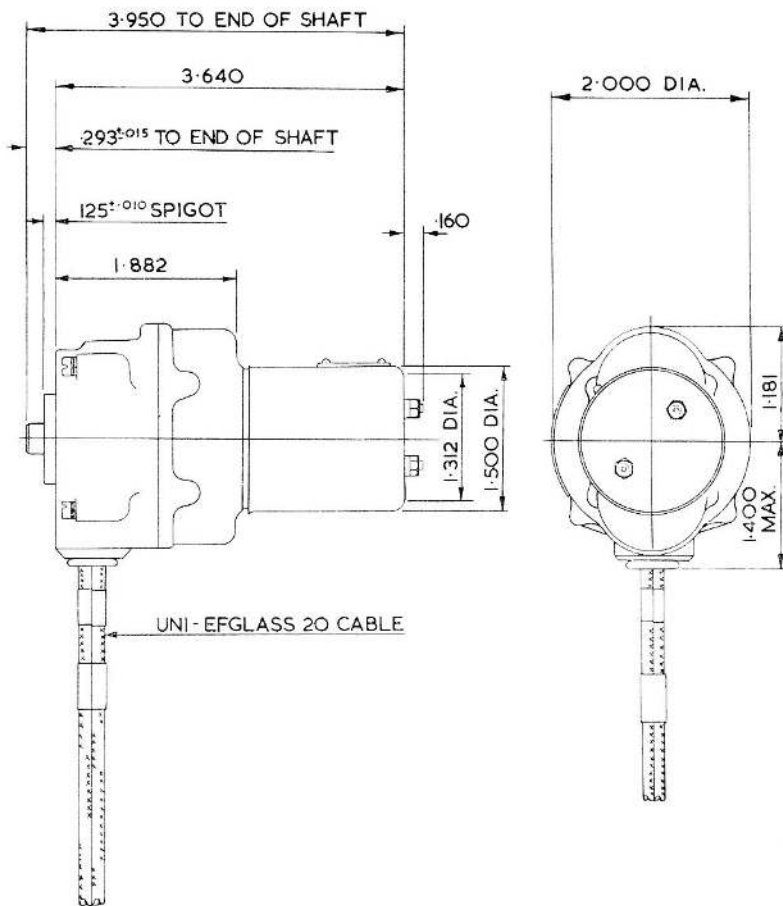

**Fig. 2. Installation details**

**RESTRICTED**

## Appendix 15

### ACTUATOR, ROTAX, TYPE C5050

#### LEADING PARTICULARS

<b>Actuator, Type C5050</b> ... ..	◀Ref. No. 5W/5383▶
<i>Operating voltage range</i> ... ..	18-29V
<i>Current consumption at 28V on normal load</i> ... ..	0.70 amp.
<i>Normal voltage</i> ... ..	28V
<i>Normal load</i> ... ..	13.5 lb. in.
<i>Maximum load</i> ... ..	25 lb. in.
<i>Maximum static load</i> ... ..	90 lb. in.
<i>Angular travel</i> ... ..	46 deg.
<i>Angular variation of stop positions</i> ... ..	± 2 deg.
<i>Time of travel on normal load</i> ... ..	1.3 sec. (max.)
<i>Ambient temperature range</i> ... ..	- 40 deg. C. to + 90 deg. C.
<i>Brush spring pressure at 0.172 in.</i> ... ..	1.25 oz.
<i>Brush length (new)</i> ... ..	0.199 - 0.214 in.
<i>Brush length (minimum)</i> ... ..	0.125 in.
<i>Commutator dia. (new)</i> ... ..	0.351 in.
<i>Commutator dia. (minimum)</i> ... ..	0.335 in.
<i>Reduction gearing ratio</i> ... ..	2,334 : 1
<i>Length</i> ... ..	4.078 in.
<i>Weight</i> ... ..	12 oz.

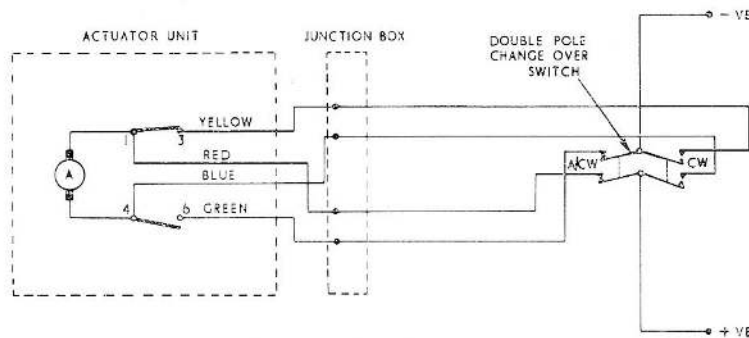

Fig. 1. Circuit diagram

1. The C5050 actuator is similar to the one described in the main chapter, but is sealed against the ingress of water. ◀It was initially provisioned for the H.P. fuel cocks on the Gnome engine in Wessex helicopters on which no pilots indication is provided, in this installation it is superseded by the Rotax Type C5061 (Ref. No. 5W/5997) when Gnome Mod. 1251 is embodied.▶ No adapter housing is fitted; four holes tapped 4 B.A. × 0.218 in. deep on a 1.250 P.C.D. are provided in the intermediate housing at the drive end of the unit for mounting purposes.

2. Electrical connections are made to this actuator by way of a four-pole Plessey plug UK-AN(ET)-5000-14S-2P, and connected externally as shown in fig. 1.

3. Information given in the main chapter regarding installation and servicing is applicable to this actuator. For details of installation in a particular aircraft, reference must be made to the relevant Aircraft Handbook. An installation diagram is shown in fig. 2.

**RESTRICTED**

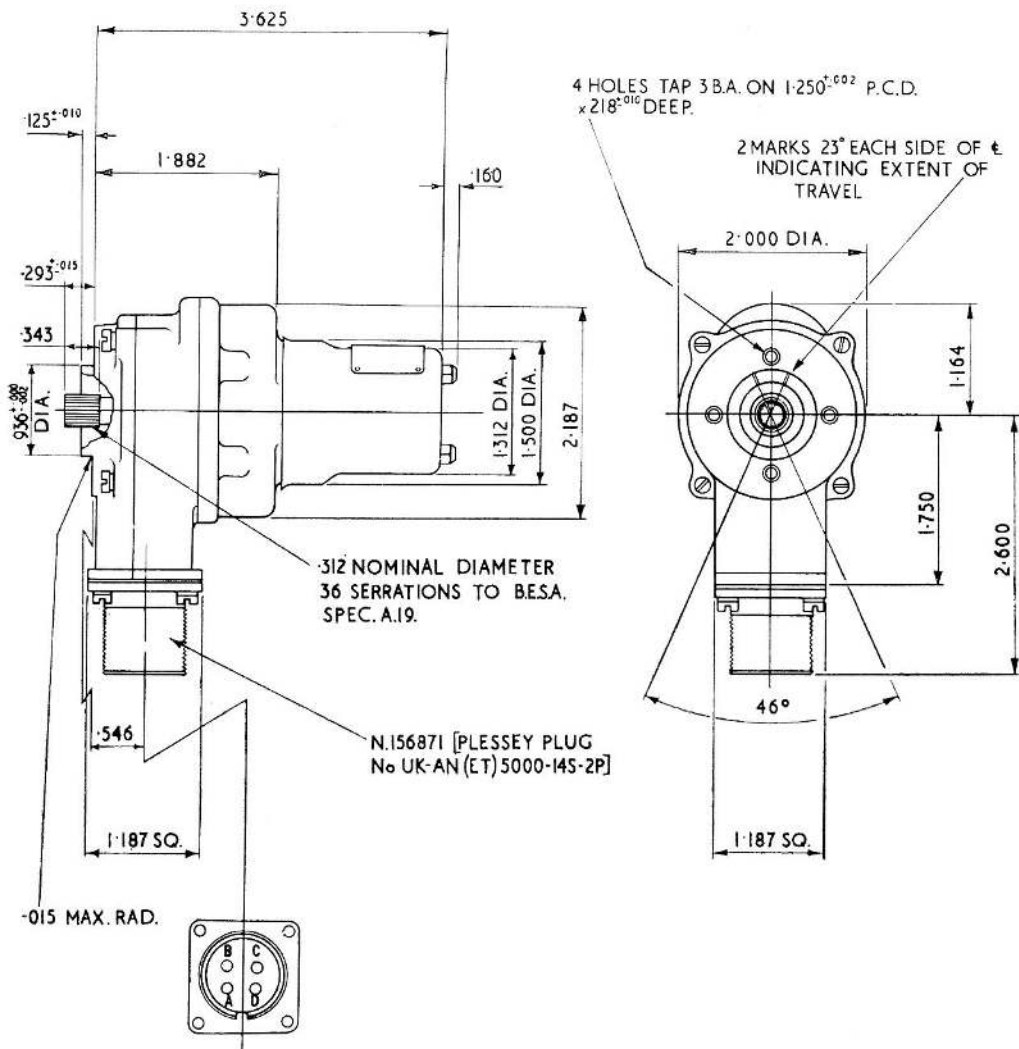

Fig. 2. Installation details

RESTRICTED

## Appendix 16

### ACTUATOR, ROTAX, TYPE C5052

#### LEADING PARTICULARS

<b>Actuator, Type C5052</b> ... ..	<b>Ref. No. 5W/</b>
<i>Operating voltage range</i> ... ..	18 - 29V
<i>Current consumption at 28V on normal load</i> ... ..	0.65 amp.
<i>Nominal voltage</i> ... ..	28V
<i>Normal load</i> ... ..	30 lb. in.
<i>Maximum load</i> ... ..	50 lb. in.
<i>Maximum static load</i> ... ..	90 lb.
<i>Angular travel</i> ... ..	90 deg.
<i>Angular variation of stop positions</i> ... ..	± 2 deg.
<i>Time of travel on normal load</i> ... ..	4.3 sec. (max.)
<i>Ambient temperature</i> ... ..	- 60 deg. C. to +90 deg. C.
<i>Brush spring pressure at 0.172 in.</i> ... ..	1.25 oz.
<i>Brush length (new)</i> ... ..	0.199 - 0.214 in.
<i>Brush length (minimum)</i> ... ..	0.125 in.
<i>Commutator dia. (new)</i> ... ..	0.351 in.
<i>Commutator dia. (minimum)</i> ... ..	0.335 in.
<i>Reduction gearing ratio (8-stage)</i> ... ..	4,450 : 1
<i>Length</i> ... ..	4.640 in.
<i>Weight</i> ... ..	1 lb.

1. The C5052 actuator is similar to the one described in the main chapter, but is sealed against the ingress of water. No adaptor housing is fitted; four holes tapped 4 B.A. × 0.218 in. deep on a 1.250 P.C.D. are provided in the intermediate housing at the drive end of the unit for mounting purposes.

2. Electrical connections are made with

2 ft. of Uninyvin 20 cable and connected externally as shown in fig. 1.

3. Information given in the main chapter regarding installation and servicing is applicable to this actuator. For details of installation in a particular aircraft, reference must be made to the relevant Aircraft Handbook. An installation diagram is shown in fig. 2.

**RESTRICTED**

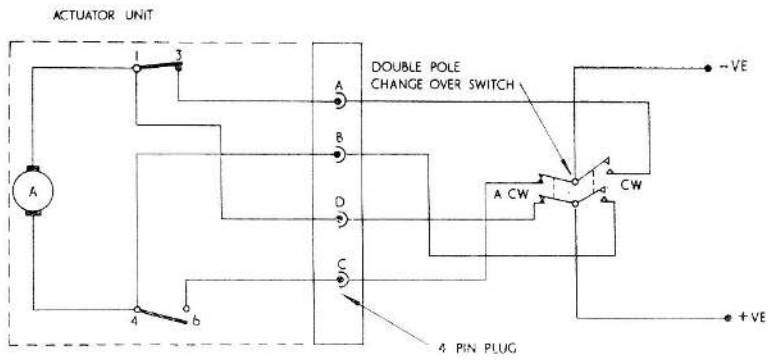

Fig. 1. Circuit diagram

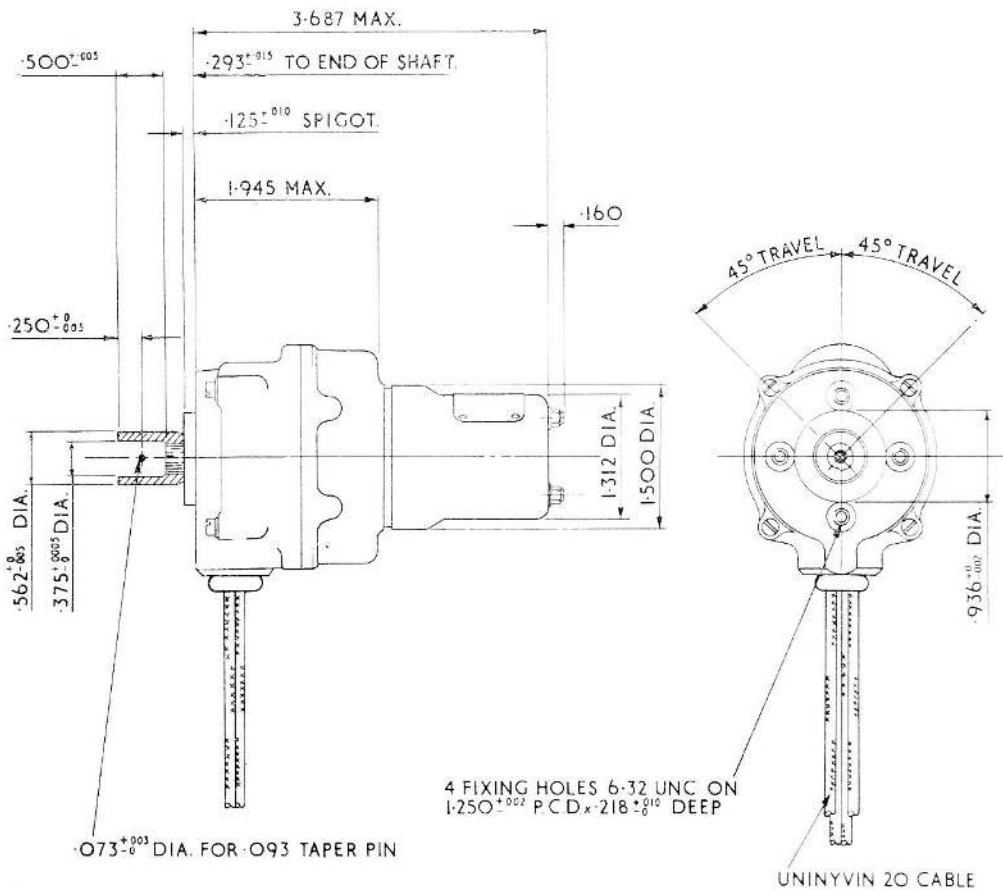

Fig. 2. Installation details

RESTRICTED

## Appendix 17

### ACTUATOR, ROTAX, TYPE C5053

#### LEADING PARTICULARS

<b>Actuator, Type C5053</b> ... ..	◀ Ref. No. 5W/5434 ▶
<i>Operating voltage range</i> ... ..	18 - 29V d.c.
<i>Current consumption at 28V on normal load</i> ... ..	0.70 amp.
<i>Normal voltage</i> ... ..	28V d.c.
<i>Normal load</i> ... ..	13.5 lb. in.
<i>Maximum load</i> ... ..	40 lb. in.
<i>Maximum static load</i> ... ..	90 lb. in.
<i>Angular travel</i> ... ..	46 deg.
<i>Angular variation of stop positions</i> ... ..	± 1½ deg. (at normal load)
<i>Time of travel (normal load)</i> ... ..	1.3 sec. (max.)
<i>Ambient temperature</i> ... ..	-40 deg. C. to +90 deg. C.
<i>Brush spring pressure (at 0.172 in.)</i> ... ..	1.25 oz.
<i>Brush length (new)</i> ... ..	0.199 in. to 0.214 in.
<i>Brush length (minimum permissible)</i> ... ..	0.125 in.
<i>Commutator diameter (new)</i> ... ..	0.350 in. to 0.352 in.
<i>Commutator diameter (minimum permissible)</i> ... ..	0.335 in.
<i>Overall dimensions —</i> ... ..	
<i>Length (over output shaft)</i> ... ..	4.078 in.
<i>Width</i> ... ..	2.000 in.
<i>Height</i> ... ..	3.826 in.
<i>Reduction gear ratio</i> ... ..	2,334 : 1
<i>Weight</i> ... ..	12 oz.

1. The C5053 actuator is similar to others in the series; the angular travel of the output shaft is 46 degrees, and extremes of clockwise and anti-clockwise travel are indicated by saw cuts in the end of the output shaft and the end face of the mounting spigot (fig. 2).

2. External indicator lamp contacts for the OPEN and SHUT positions of the equipment which is being operated by the actuator are shown in the circuit diagram (fig. 1). ◀ This facility is used in later Wessex helicopters where the actuator is used for the H.P. fuel cocks, in this installation it is superseded by the Rotax actuator Type C5062 (Ref. No. 5W/5998) when Gnome Mod. 1251 is embodied. ▶

3. Electrical connection to the actuator is via a six-pole Plessey plug, UK-AN(ET)-

5300-14S-6P. For connections to the associated equipment reference should be made to fig. 1.

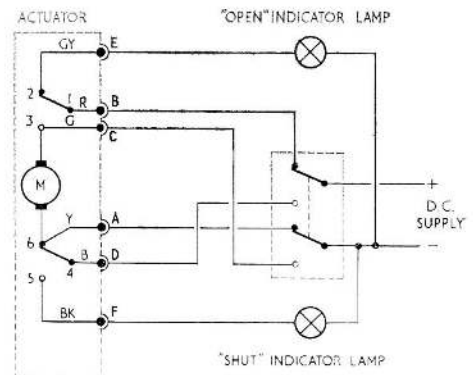

◀ Fig. 1. Circuit diagram ▶

**RESTRICTED**

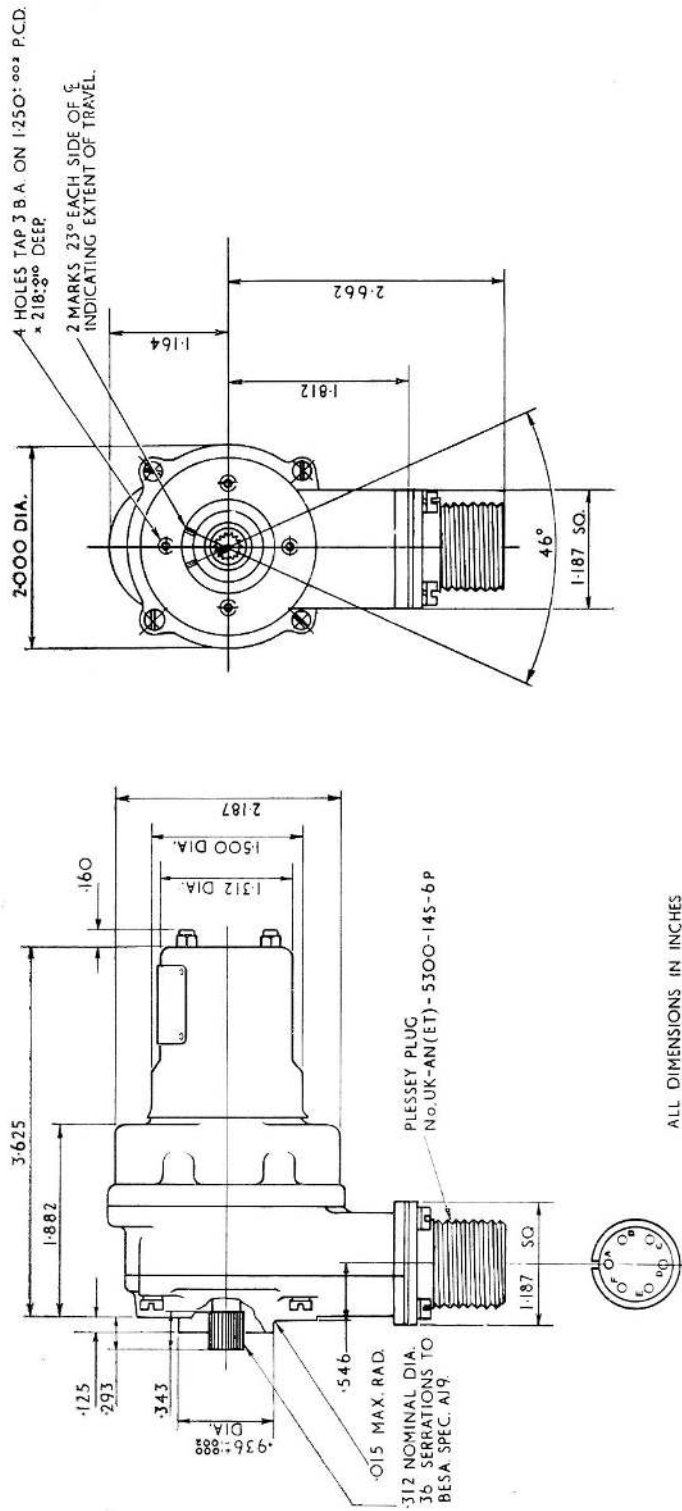

◀ Fig. 2. Installation details ▶

RESTRICTED

## Appendix 18

## ACTUATOR, ROTAX, TYPE C5058

## LEADING PARTICULARS

<b>Actuator, Type C5058</b> ... ..	<b>Ref. No. 5W/</b>
<i>Operating voltage range</i> ... ..	18 - 29V
<i>Current consumption at 28V on normal load</i> ... ..	3 amp.
<i>Normal voltage</i> ... ..	28V
<i>Normal load</i> ... ..	30 lb. in.
<i>Maximum load</i> ... ..	90 lb. in.
<i>Maximum static load</i> ... ..	90 lb. in.
<i>Angular travel</i> ... ..	90 deg.
<i>Angular variation of stop positions</i> ... ..	± 2 deg.
<i>Time of travel on normal load</i> ... ..	1.9 sec. (max.)
<i>Ambient temperature range</i> ... ..	-40 deg. C. to +120 deg. C.
<i>Time rating</i> ... ..	30 sec.
<i>Brush spring pressure at 0.172 in.</i> ... ..	1.25 oz.
<i>Brush length (new)</i> ... ..	0.199 in. to 0.214 in.
<i>Brush length (minimum)</i> ... ..	0.125 in.
<i>Commutator dia. (new)</i> ... ..	0.351 in.
<i>Commutator dia. (minimum)</i> ... ..	0.335 in.
<i>Reduction gearing ratio (8-stage)</i> ... ..	4,450 : 1
<i>Length</i> ... ..	4.093 in.
<i>Weight</i> ... ..	12 oz.

1. The C5058 actuator is similar to the one described in the main chapter; it is sealed against the ingress of water and does not have an adapter housing fitted; four holes tapped 4 B.A. × 0.218 in. deep on a 1.250 P.C.D. are provided in the intermediate housing at the drive end of the unit for mounting purposes.

2. To restrict overrun, a dynamic brake has been incorporated in this actuator, and forms part of the brush retaining ring.

3. Electrical connections are made by a four-pole Plessey plug, UK-AN(ET)-5000-14S-2P, and connected externally as shown in the circuit diagram (fig. 1).

4. Information given in the main chapter regarding installation and servicing is applicable to this actuator. For details of installation in a particular aircraft, reference must be made to the relevant Aircraft Handbook. An installation diagram is shown in fig. 2.

RESTRICTED

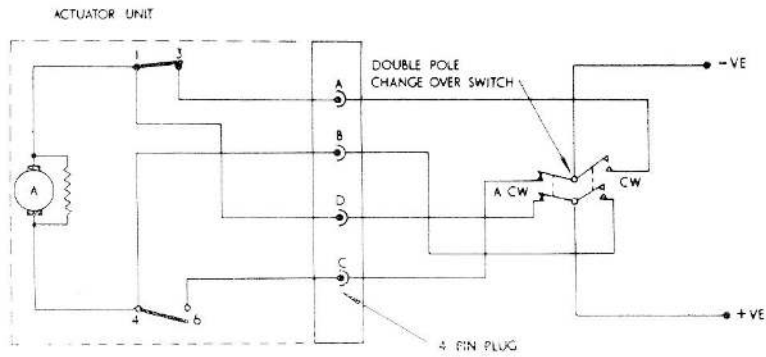

Fig. 1. Circuit diagram

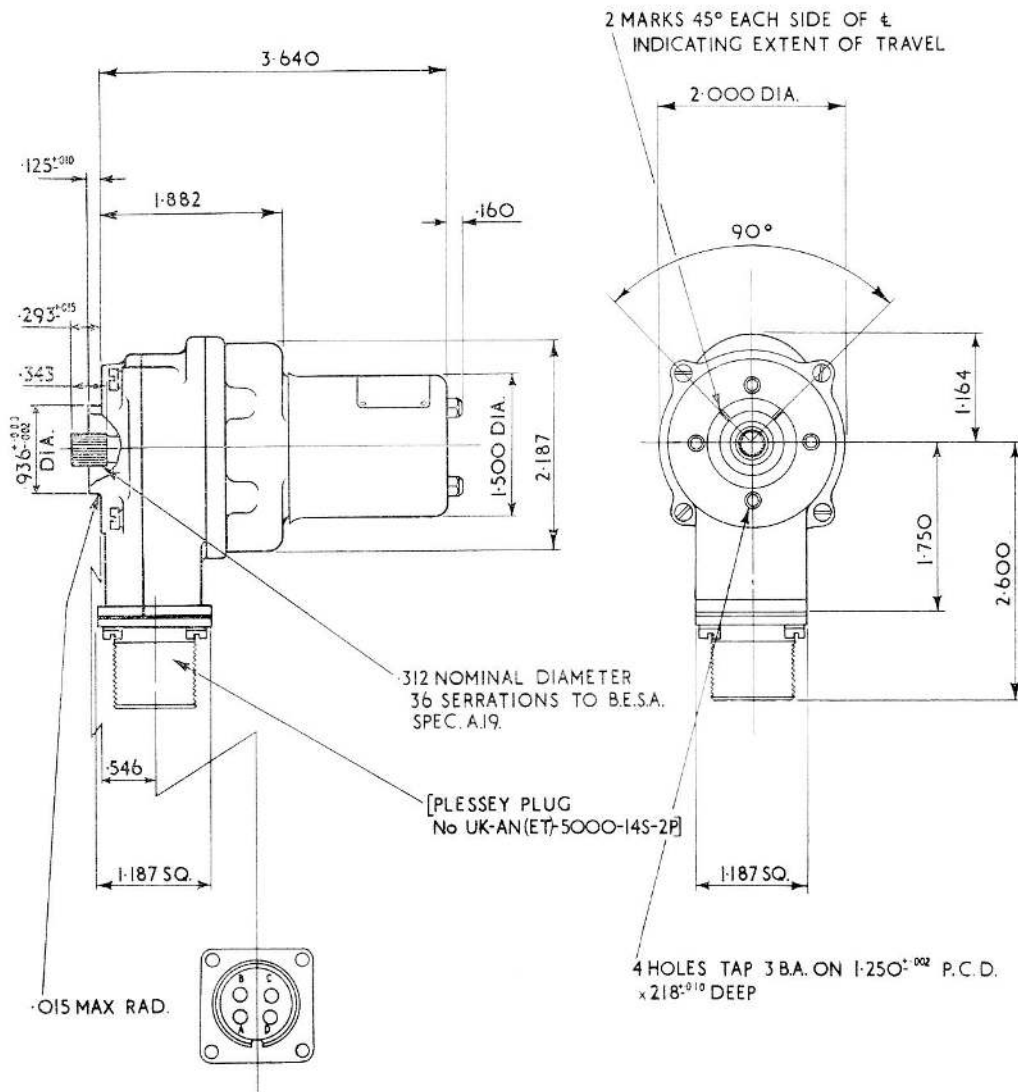

Fig. 2. Installation details

**RESTRICTED**

This file was downloaded  
from the RTFM Library.

Link: [www.scottbouch.com/rtfm](http://www.scottbouch.com/rtfm)

Please see site for usage terms,  
and more aircraft documents.

