

## Chapter 14

## ACTUATORS, ROTAX, C5500 SERIES

## LIST OF CONTENTS

	<i>Para.</i>		<i>Para.</i>
<i>Introduction</i> ... ..	1	<i>Electrical connection</i> ... ..	12
<b>Description</b> ... ..	3	<b>Installation</b> ... ..	13
<i>Solenoid brake</i> ... ..	4	<b>Servicing</b> ... ..	14
<i>Motor</i> ... ..	6	<i>Brushgear</i> ... ..	15
<i>Gear housing</i> ... ..	8	<i>Lubrication</i> ... ..	16
<i>Switch housing</i> ... ..	9	<i>Testing</i> ... ..	17
<i>Limit switches</i> ... ..	11		

## LIST OF APPENDICES

	<i>App.</i>		<i>App.</i>
<i>Standard serviceability test for actuators, Rotax, C5500 series</i> ...	A	<i>Actuator, Rotax, Type C5521</i> ...	8
<i>Actuator, Rotax, Type C5510/3</i> ...	1	<i>Actuator, Rotax, Type C5523/2</i> ...	9
<i>Actuator, Rotax, Type C5511/2</i> ...	2	<i>Actuator, Rotax, Type C5524/2</i> ...	10
<i>Actuator, Rotax, Type C5512/2</i> ...	3	<i>Actuator, Rotax, Type C5527</i> ...	11
<i>Actuator, Rotax, Type C5513/2</i> ...	4	<i>Actuator, Rotax, Type C5530/1</i> ...	12
<i>Actuator, Rotax, Type C5514/4</i> ...	5	<i>Actuator, Rotax, Type C5519</i> ...	13
<i>Actuator, Rotax, Type C5517/2</i> ...	6	<i>Actuator, Rotax, Type C5536</i> ...	14
<i>Actuator, Rotax, Type C5520</i> ...	7	<i>Actuator, Rotax, Type C5537/1</i> ...	15

RESTRICTED

## Introduction

1. These actuators are for general application in aircraft having a 28-volt d.c. supply. They are rotary types with angular travel of the output shaft controlled by two incorporated limit switches; in certain actuators within the series the wiring is so arranged that these provide an external indication, when the output shaft is in the fully clockwise or anti-clockwise position.

2. Since the actuators within the C5500 series vary considerably, this chapter gives a general description only; for details of various features of individual actuators and diagrams of internal connections, reference must be made to the relevant Appendices to this chapter.

## DESCRIPTION

3. The actuators in the C5500 series are of in-line construction, and include a reversible motor which can be operated within a voltage range of 18 to 29 volts d.c. Generally speaking, the machines comprise four main assemblies, viz., motor, solenoid brake, gear housing and switch housing. The switch housing is a composite assembly which includes output shaft, supply cable or external plug, and two plain bearings; in certain actuators a clutch is also incorporated.

### Solenoid brake

4. A coil connected in series with the motor armature is wound on a bobbin and interposed between a plunger and a steel plate; the latter is known as the brake anvil, and encloses the end of the brake housing. A cavity in the anvil and another in the plunger house each end of a helical spring which passes through the bore of the bobbin. The plunger is faced with a surface of Langite, and, being free to move under the influence of the spring, exerts lateral pressure on a non-magnetic steel disc which is coupled to the armature shaft.

5. When the brake coil is energized the brake plunger is withdrawn from contact with the steel disc against the influence of the brake spring. The brake will therefore be automatically applied when the coil is de-energized, i.e., when the motor is switched off.

## Motor

6. The motor is a 2-pole, 2-brush machine, split series wound; one field is used for each direction of rotation. A moulding interposed between the brake and the motor yoke contains the brush boxes, and houses a ball bearing which supports the brake disc, in the bore of which is the commutator end of the armature shaft. The driving end of the armature shaft is located in a pinion borne by a ball bearing housed in the gear housing assembly.

7. The brake housing and moulding are normally enclosed by a screw-on-cap, locked in position by a wire clip held in a retaining groove. One end of the clip passes through the cap and enters a locating hole drilled through the threaded part of the motor casing. In some earlier actuators, the cover is retained by a clip which passes over the end of the cover.

### Gear housing

8. This housing contains a multiple stage spur gear train assembled about three lay shafts, of which two (outer) are fixed. The third (central) lay shaft is secured to a pinion which is integral with the output shaft. The gearing produces a step-down ratio, armature to output shaft, which varies with the number of stages employed.

### Switch housing

9. A casting, secured to the gear housing by four screws, contains the limit switch assembly and provides a mounting for the supply plug, or cable and gland entry or grommet, whichever may be required for the actuator.

10. The casting is bored out, on the motor axis, to provide an end plate in which a plain bearing is housed. This bearing carries the output shaft where it emerges from the gearbox. The hollow part of the casting houses the limit switches, with the output shaft passing through the centre. Enclosing the housing is an end plate which supports the output shaft at its driving end in a plain bronze bearing. The end plate provides the means for mounting the actuator, and on its external face it has a spigot which is marked by two saw cuts. These markings indicate

**RESTRICTED**

the extremities of travel of a datum line cut in the end of the output shaft. In some actuators, a visual indicator is fitted over the shaft so that it shows the stop position through a special adapter housing.

### Limit switches

11. There are normally two limit switches in the actuators. These switches are mounted on, and form part of, the switch plate assembly. The output shaft passes through the plate assembly and supports the two cams which operate the limit switches when the output shaft is in the fully clockwise or anti-clockwise position.

### Electrical connection

12. Electrical connection to these actuators is made either by means of a plug secured to a mounting integral with the switch housing, or by a length of cable entering the switch housing through a grommet or screwed gland nut; details will be found in the appropriate Appendix.

## INSTALLATION

13. Steel inserts are normally provided in the drive end plates for mounting purposes, some being tapped 2 B.A. and others 4 B.A.; the depth of tappings is usually 0.218 in. The units can be mounted in any attitude.

14. These actuators should be serviced in accordance with the general chapter in A.P. 4343, Vol. 1, Sect. 17, Chap. 1, and the instructions contained in the relevant Servicing Schedule.

### Brushgear

15. Service the brushgear in the following manner:—

- (1) Release the wire clip locking the end cap.

- (2) Remove the end cap, thus exposing the brushgear.

- (3) Unscrew the ch/hd. screw at each brush box that secures the brush spring retaining clip. Care should be taken when lifting out the brushes not to lose the small helical brush springs.

- (4) The minimum length beyond which brushes should not be used is 0.125 in. Brushes should be renewed at periods prescribed in the relevant Servicing Schedule, and whenever examination reveals that they will not remain serviceable for the period that must elapse before the next servicing.

- (5) Check the brush spring pressure; this should be 2.5 oz. (71 gm.), when the spring is compressed from a free length of 0.4 in. to its working length of 0.172 in.

- (6) Reassemble the brush gear and tighten the screws securing the brush spring retaining clips. Fit the motor cover and secure with the wire clip making sure that the end of the clip enters a locking hole.

### Lubrication

16. The ball bearings of the actuator are lubricated with grease XG-275 during manufacture and repair, and should not normally require lubricating during servicing periods.

### ◀ Testing

17. If the serviceability of the actuator is suspect, it may be tested as laid down in Appendix A. ▶

## Appendix A

### STANDARD SERVICEABILITY TEST FOR ACTUATORS, ROTAX, C5500 SERIES

#### Introduction

1. The following tests may be applied to the actuator before it is put into service, or at any time when its serviceability is suspect.

#### Test equipment

2. The following test equipment is required: —

- (1) Tension gauge (Ref. No. 1H/58).
- (2) Rotary actuator test rig (Ref. No. 4G/6591).
- (3) Insulation resistance tester, Type C (Ref. No. 5G/152).

#### Testing

##### *Brushgear*

3. Check the brush length and brush spring pressure; the brush length should not be less than 0.125 in., and the spring pressure should be 2.5 oz. (71 gm.), when the spring is compressed from a free length of 0.4 in. to its working length of 0.172 in.

#### *Performance*

4. Set the actuator on the test rig, using the appropriate fittings as indicated in Table 1, and ensure that it operates within the limits given in Table 2. The tests should be made for each direction of rotation, and at 28 volts.

**TABLE 1**  
**Actuator fittings**

Type	Adapter	Drive coupling
C5510/3	8	1
C5511/2	5	2
C5512/2		
C5513/2		
C5514/4		
C5517/2	5	2
C5519	6	3
C5520	5	3
C5521		
C5523/2		
C5524/2	6	3
C5527		
C5530/1	6	3
C5536	6	3
C5537/1	2	7

**TABLE 2**  
**Test data**

Type	Angular travel (deg.)	Time of travel (sec.) (max.)		Current (amp.) (max.)			
		No load	Normal load (30 lb. in.)	Normal load (15 lb. in.)	No load	Normal load (30 lb. in.)	Normal load (15 lb. in.)
C5510/3	90	1.5	2.25		1.5	1.8	
C5511/2	180	3.0	4.5		1.5	1.8	
C5512/2	90	1.5	2.25		1.5	1.8	
C5513/2	90	1.5	2.25		1.5	1.8	
C5514/4	90	12.5	13		1.5	1.65	
C5517/2	90	1.5	2.25		1.5	1.8	
C5519	90	12.5	13		1.5	1.65	
C5520	60	8.33	8.67		1.5	1.65	
C5521	180	25	26		1.5	1.65	
C5523/2	90	1.5	2.25		1.5	1.8	
C5524/2	90	0.65		1.5	1.6		2.25
C5527	Cont.	1.5 per 90 deg.	2.25 per 90 deg.		1.5	1.8	
C5530/1	90	0.65		1.5	1.6		2.25
C5536	90	0.65		1.5	1.6		2.25
C5537/1	90	1.1	1.5		1.5	2.0	

5. The actuator must operate on 18 volts against a normal load.

*Insulation resistance*

6. The insulation resistance, measured with a 250-volt insulation resistance tester between all live parts and the frame, should be not less than 50,000 ohms.

**RESTRICTED**

## Appendix 1

### ACTUATOR, ROTAX, TYPE C5510/3

#### LEADING PARTICULARS

<b>Actuator, Type C5510/3</b> ... ..	<b>Ref. No. 5W/3350</b>
<i>Normal voltage</i> ... ..	28 volts d.c.
<i>Operating voltage range</i> ... ..	18 — 29 volts d.c.
<i>Current at normal load</i> ... ..	1·8 amp.
<i>Speed of rotation at normal load</i> ... ..	2·25 sec. per 90 deg.
<i>Normal load</i> ... ..	30 lb. in.
<i>Maximum load</i> ... ..	60 lb. in.
<i>Maximum static load</i> ... ..	90 lb. in.
<i>Ambient temperature range</i> ... ..	−40 deg. C. to +90 deg. C.
<i>Rating</i> ... ..	Intermittent
<i>Ratio of gear train</i> ... ..	2,334: 1
<i>Brush grade</i> ... ..	E.G. 14 (Ref. No. 5W/643)
<i>Brush length (new)</i> ... ..	0·226 in.
<i>Minimum brush length</i> ... ..	0·125 in.
<i>Brush spring pressure</i> ... ..	2·5 oz. (71 gm.)
<i>Operational ceiling</i> ... ..	50,000 ft.
<i>Overall dimensions—</i>	
<i>Length</i> ... ..	7·180 in.
<i>Mounting flange diameter</i> ... ..	2·55 in.
<i>Weight</i> ... ..	2 lb. 4 oz.

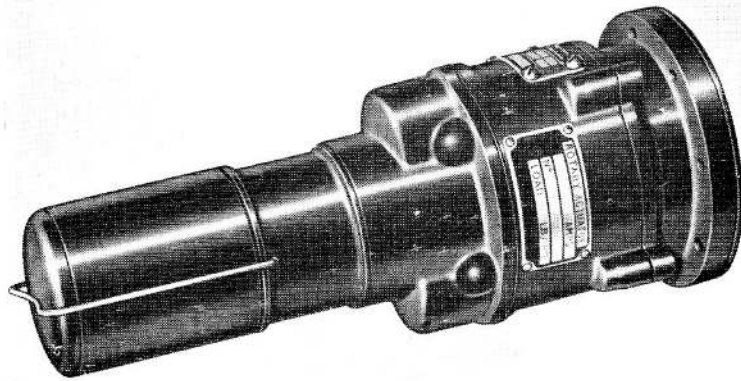

Fig. 1. Type C5510/3 actuator

RESTRICTED

1. This actuator (*fig. 1*) is generally similar to that described in the main chapter. The rotary movement of the output shaft is limited to 90 deg. by the two internal limit switches; a visual indicator enables the shaft stop position to be seen through a special adapter housings.

2. The gearbox has an eight-stage single spur gear train arranged on one central and two outer lay shafts; the final stage has two gears which drive the output shaft in tandem.

3. Electrical connection is made by a 2 ft. length of Quinprensheath 6 cable, which is taken through a gland entry secured to the housing. The internal connections are as shown in *fig. 2*.

4. The actuator is provided with four equi-

spaced mounting holes, tapped 4 B.A. on a 2.150 in. P.C.D., concentric with the output shaft. The output shaft has 36 serrations on a 0.312 in. nominal diameter.

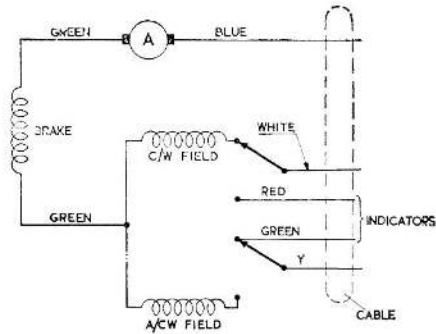

**Fig. 2. Diagram of internal connections**

## Appendix 2

### ACTUATOR, ROTAX, TYPE C5511/2

#### LEADING PARTICULARS

<b>Actuator, Type C5511/2</b> ... ..	<b>Ref. No. 5W/429</b>
<i>Normal voltage</i> ... ..	28 volts d.c.
<i>Operating voltage range</i> ... ..	18 — 29 volts d.c.
<i>Current at normal load</i> ... ..	1·8 amp.
<i>Speed of rotation at normal load</i> ... ..	2·25 sec. per 90 deg.
<i>Normal load</i> ... ..	30 lb. in.
<i>Maximum load</i> ... ..	60 lb. in.
<i>Maximum static load</i> ... ..	90 lb. in.
<i>Ambient temperature range</i> ... ..	−40 deg. C. to +90 deg. C.
<i>Rating</i> ... ..	Intermittent
<i>Ratio of gear train</i> ... ..	2,334: 1
<i>Brush grade</i> ... ..	E.G. 14 (Ref. No. 5W/643)
<i>Brush length (new)</i> ... ..	0·226 in.
<i>Minimum brush length</i> ... ..	0·125 in.
<i>Brush spring pressure</i> ... ..	2·5 oz. (71 gm.)
<i>Operational ceiling</i> ... ..	50,000 ft.
<i>Overall dimensions—</i>	
<i>Length</i> ... ..	6·081 in.
<i>Width</i> ... ..	2·362 in.
<i>Height</i> ... ..	2·315 in.
<i>Weight</i> ... ..	1 lb. 2 oz.

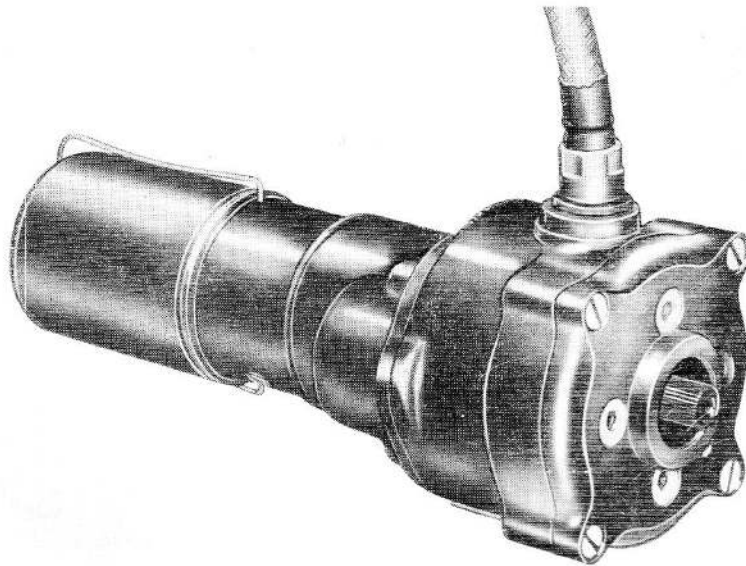

Fig. 1. Type C5511/2 actuator

RESTRICTED

1. This actuator (*fig. 1*) is generally similar to that described in the main chapter. The rotary movement of the output shaft is limited to 180 deg. by the two internal limit switches; on the external face of the end plate is a spigot marked by two sawcuts, which indicate the extremities of travel of a datum line cut in the end of the output shaft.

2. The gearbox has an eight-stage single spur gear train arranged on one central and two outer lay shafts; the final stage has two gears which drive the output shaft in tandem.

3. Electrical connection is made by a 15 in. length of Quinpremet 6 cable which is taken through a gland entry screwed to the housing; the internal connections are as shown in *fig 2*.

4. The actuator is provided with four mounting holes in the drive end plate. They are tapped 4 B.A. to a depth of 0.218 in., and are equispaced on a 1.25 in. P.C.D. with a 0.936 in. dia. spigot for locating to the associated equipment.

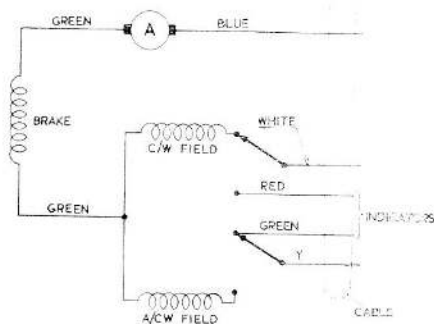

Fig. 2. Diagram of internal connections

## Appendix 3

## ACTUATOR, ROTAX, TYPE C5512/2

## LEADING PARTICULARS

<b>Actuator, Type C5512/2</b> .....	<b>Ref. No. 5W/</b>
<i>Normal voltage</i> .....	28 volts d.c.
<i>Operating voltage range</i> .....	18 — 29 volts d.c.
<i>Current at normal load</i> .....	1.8 amp.
<i>Speed of rotation at normal load</i> .....	2.25 sec. per 90 deg.
<i>Normal load</i> .....	30 lb. in.
<i>Maximum load</i> .....	60 lb. in.
<i>Maximum static load</i> .....	90 lb. in.
<i>Ambient temperature range</i> .....	—40 deg. C. to +90 deg. C.
<i>Rating</i> .....	Intermittent
<i>Ratio of gear train</i> .....	2,334:1
<i>Brush grade</i> .....	E.G. 14 (Ref. No. 5W/643)
<i>Brush length (new)</i> .....	0.226 in.
<i>Minimum brush length</i> .....	0.125 in.
<i>Brush spring pressure</i> .....	2.5 oz. (71 gm.)
<i>Operational ceiling</i> .....	50,000 ft.
<i>Overall dimensions—</i>	
<i>Length</i> .....	6.333 in.
<i>Width</i> .....	2.625 in.
<i>Height</i> .....	4.406 in.
<i>Weight</i> .....	2 lb.

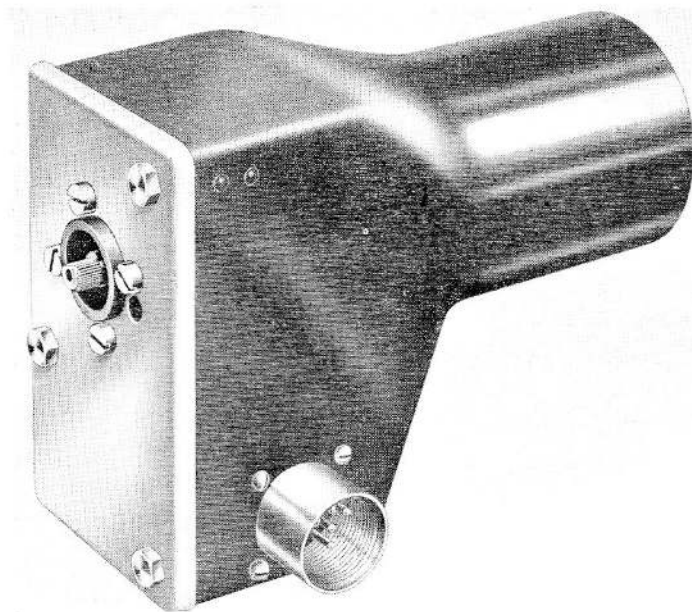
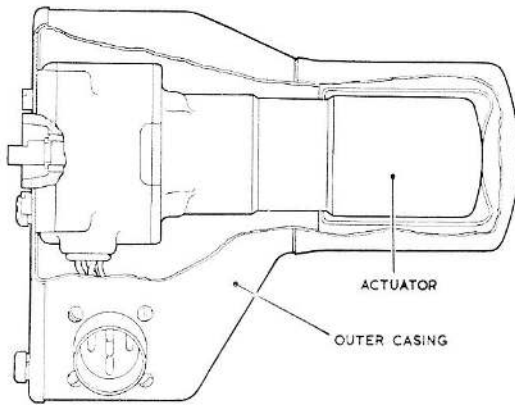

Fig. 1. Type C5512/2 actuator

RESTRICTED



**Fig. 2. Partly sectioned view of actuator**

1. This actuator (*fig. 1*) is generally similar to that described in the main chapter, but is completely encased within an outer flame-proof metal casing (consisting of a main case screwed to a front cover plate), with only the output shaft and mounting spigot protruding (*fig. 2*). The complete actuator is removable from the case as a unit.

2. The rotary movement of the output shaft is limited to 90 deg. by the two internal limit switches. The gearbox has an eight stage single spur gear train arranged on one central and two outer lay shafts; the final stage has two gears which drive the output shaft in tandem.

3. Electrical connection is made by a five-pole Breeze plug (Ref. No. 5X/6016, mounted on the right-hand side of the case (looking on the output shaft end); the internal connections are as shown in the circuit diagram in *fig. 3*.

4. The actuator is provided with four mounting holes, tapped 3 B.A., on the front

surface, equispaced on a 1.25 in. P.C.D. concentric with the output shaft, and corresponding clearance holes through the front cover plate of the outer case.

5. When the actuator is supplied from Stores, four transit screws are inserted in these holes, securing the outer case to the actuator. To mount the actuator, remove the three hex/hd. screws which secure the front cover plate of the outer case to the main part of the case, and draw the cover from the main case with the actuator secured to the cover by the transit screws and attached to the main case by the leads to the plug.

6. Remove the transit screws, and locate the actuator with the outer case cover plate between the actuator and its mounting. Secure the actuator with four mounting screws, and finally fit the outer case to the cover plate by replacing the three screws.

7. The output shaft has 36 serrations in a 0.312 in. nominal diameter, with a flat extending 0.25 in. from the end of the shaft.

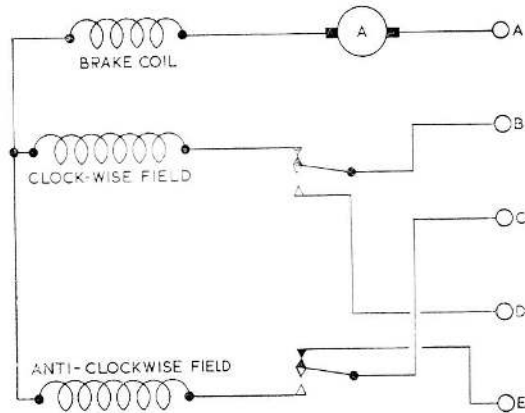

**Fig. 3. Diagram of internal connections**

## Appendix 4

### ACTUATOR, ROTAX, TYPE C5513/2

#### LEADING PARTICULARS

<b>Actuator, Type C5513/2</b> .....	<b>Ref. No. 5W/</b>
Normal voltage .....	28 volts d.c.
Operating voltage range .....	18 — 29 volts d.c.
Current at normal load .....	1.8 amp.
Speed of rotation at normal load .....	2.25 sec. per 90 deg.
Normal load .....	30 lb. in.
Maximum load .....	60 lb. in.
Maximum static load .....	90 lb. in.
Ambient temperature range .....	-40 deg. C. to +90 deg. C.
Rating .....	Intermittent
Ratio of gear train .....	2,334:1
Brush grade .....	E.G. 14 (Ref. No. 5W/643)
Brush length (new) .....	0.226 in.
Minimum brush length .....	0.125 in.
Brush spring pressure .....	2.5 oz. (71 gm.)
Operational ceiling .....	50,000 ft.
Overall dimensions—	
Length .....	6.333 in.
Width .....	2.625 in.
Height .....	4.406 in.
Weight .....	2 lb.

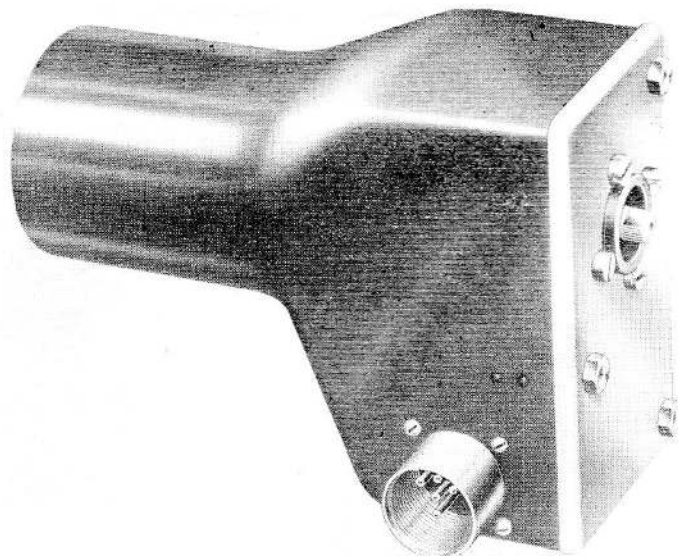

Fig. 1. Type C5513/2 actuator

RESTRICTED

1. This actuator (*fig. 1*) is generally similar to that described in the main chapter, but is complete encased within an outer flame-proof metal casing (consisting of a main case screwed to a front cover plate), with only the output shaft and mounting spigot protruding. The complete actuator is removable from the case as a unit.

2. The rotary movement of the output shaft is limited to 90 deg. by the two internal limit switches. The gearbox has an eight stage single spur gear train arranged on one central and two outer lay shafts; the final stage has two gears which drive the output shaft in tandem.

3. Electrical connection is made by a five-pole Breeze plug (Ref. No. 5X/6016), mounted on the left-hand side of the case (looking on the output shaft end); the internal connections are as shown in the circuit diagram in *fig. 2*.

4. The actuator is provided with four mounting holes, tapped 3 B.A., on the front surface, equispaced on a 1.25 in. P.C.D. concentric with the output shaft, and corresponding clearance holes through the front cover plate of the outer case.

5. When the actuator is supplied from Stores, four transit screws are inserted in these holes, securing the outer case to the

actuator. To mount the actuator, remove the three hex/hd. screws which secure the front cover plate of the outer case to the main part of the case, and draw the cover from the main case with the actuator secured to the cover by the transit screws and attached to the main case by the leads to the plug.

6. Remove the transit screws, and locate the actuator with the outer case cover plate between the actuator and its mounting. Secure the actuator with four mounting screws, and finally fit the outer case to the cover plate by replacing the three screws.

7. The output shaft has 36 serrations in a 0.312 in. nominal diameter, with a flat extending 0.25 in. from the end of the shaft.

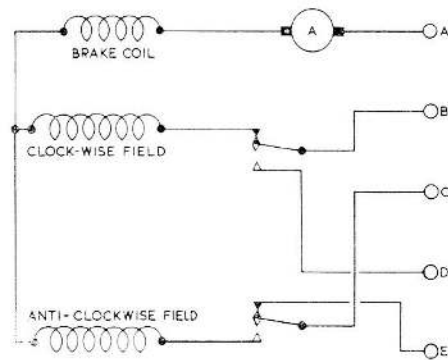

**Fig. 2. Diagram of internal connections**



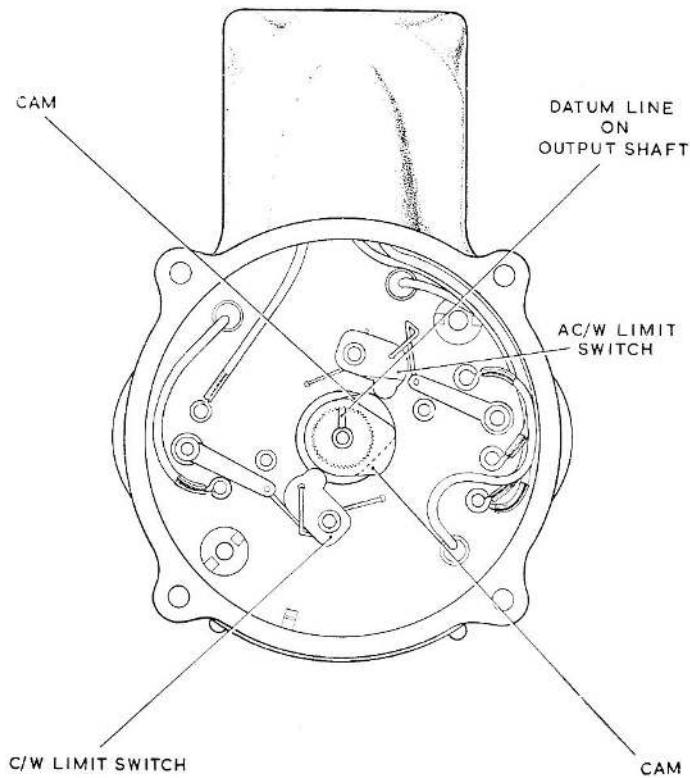

**Fig. 2. Limit switches and cams**

1. The actuator (*fig. 1*) is generally similar to that described in the main chapter. The rotary movement of the output shaft is limited to 90 deg. by the two internal limit switches; on the external face of the end plate is a spigot marked by two sawcuts, which indicate the extremities of travel of a datum line cut in the end of the output shaft. (*fig. 2*).

2. The gearbox contains a ten-stage spur gear train assembled about three layshafts, of which two (outer) are fixed. The third (central) lay shaft is secured to a pinion integral with the output shaft.

3. Electrical connection is made by a four-pole plug (Ref. No. 5X/6006) which is mounted above the actuator but in line with its axis. The internal connections are as shown in *fig. 3*.

4. The actuator is provided with four mounting holes in the drive end plate. They are tapped 4 B.A. to a depth of 0.218 in. on a 1.25 in. P.C.D. with a 0.936 in. dia. spigot for locating to the associated equipment.

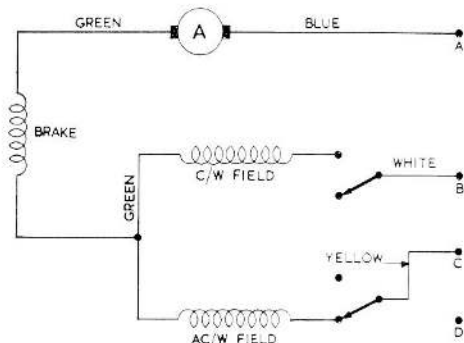

**Fig. 3. Diagram of internal connections**

## Appendix 6

### ACTUATOR, ROTAX, TYPE C5517/2

#### LEADING PARTICULARS

<b>Actuator, Type C5517/2</b> ... ..	<b>Ref. No. 5W/389</b>
<i>Normal voltage</i> ... ..	28 volts d.c.
<i>Operating voltage range</i> ... ..	18 — 29 volts d.c.
<i>Current at normal load</i> ... ..	1·8 amp.
<i>Speed of rotation at normal load</i> ... ..	2·25 sec. per 90 deg.
<i>Normal load</i> ... ..	30 lb. in.
<i>Maximum load</i> ... ..	60 lb. in.
<i>Maximum static load</i> ... ..	90 lb. in.
<i>Ambient temperature range</i> ... ..	−40 deg. C. to +90 deg. C.
<i>Rating</i> ... ..	Intermittent
<i>Ratio of gear train</i> ... ..	2,334: 1
<i>Brush grade</i> ... ..	E.G. 14 (Ref. No. 5W/643)
<i>Brush length (new)</i> ... ..	0·226 in.
<i>Minimum brush length</i> ... ..	0·125 in.
<i>Brush spring pressure</i> ... ..	2·5 oz. (71 gm.)
<i>Operational ceiling</i> ... ..	50,000 ft.
<i>Overall dimensions—</i>	
<i>Length</i> ... ..	6·081 in.
<i>Width</i> ... ..	2·362 in.
<i>Height</i> ... ..	2·315 in.
<i>Weight</i> ... ..	1 lb. 2 oz.

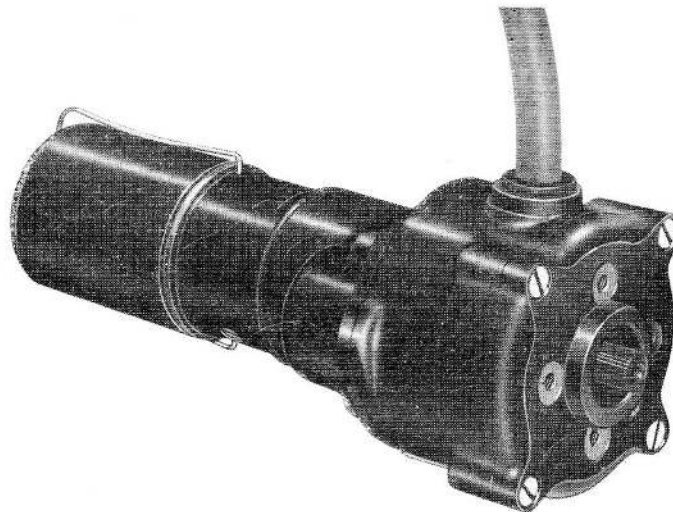

Fig. 1. Type C5517/2 actuator

RESTRICTED

1. This actuator (*fig. 1*) is generally similar to that described in the main chapter. The rotary movement of the output shaft is limited to 90 deg. by the two internal limit switches.

2. The gearbox has an eight stage single spur gear train arranged on one central and two outer lay shafts; the final stage has two gears, one on each outer lay shaft, which drive the output shaft in tandem.

3. Electrical connection is made by a 15 in. length of Quinpresheath 6 cable which is taken through a rubber grommet from the switch housing; the internal connections are as shown in *fig. 2*.

4. The actuator is provided with four mounting holes in the drive end frame. They

are tapped 4 B.A. to a depth of 0.218 in., and are equispaced on a 1.25 in. P.C.D. The output shaft has 36 serrations cut into a 0.312 in. nominal diameter.

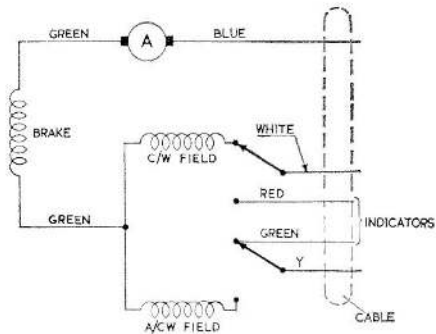

**Fig. 2. Diagram of internal connections**



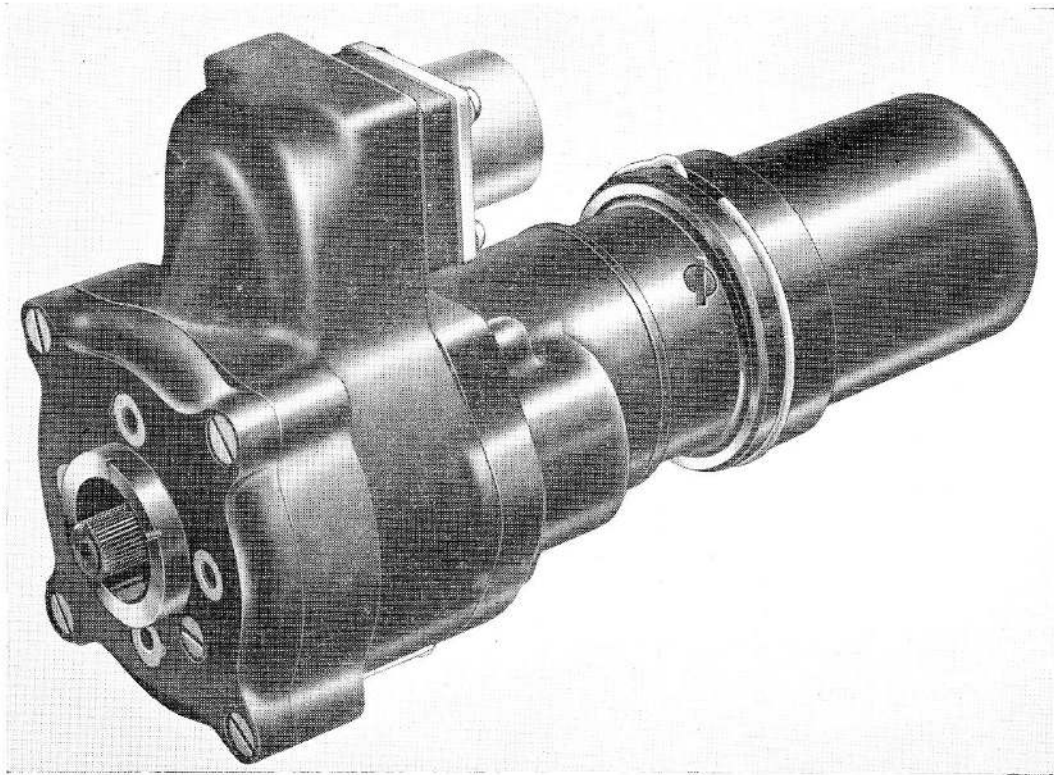

**Fig. 1. Type C5520 actuator**

**1.** This actuator (*fig. 1*) is generally similar to that described in the main chapter. The rotary movement of the output shaft is limited to 60 deg. by the two internal limit switches; on the external face of the end plate is a spigot marked by two sawcuts, which indicate the extremities of travel of a datum line cut in the end of the output shaft (*fig. 2*).

**2.** The gearbox contains a ten-stage spur gear train assembled about three lay shafts, of which two (outer) are fixed. The third

(central) lay shaft is secured to a pinion integral with the output shaft.

**3.** Electrical connection is made by a four-pole plug (Ref. No. 5X/6006), which is mounted above the actuator but in line with its axis. The internal connections are as shown in the circuit diagram in *fig. 2*.

**4.** The actuator is provided with four mounting holes in the drive end plate. They are tapped 4 B.A. to a depth of 0.218 in., and are equispaced on a 1.25 in. P.C.D.

**RESTRICTED**

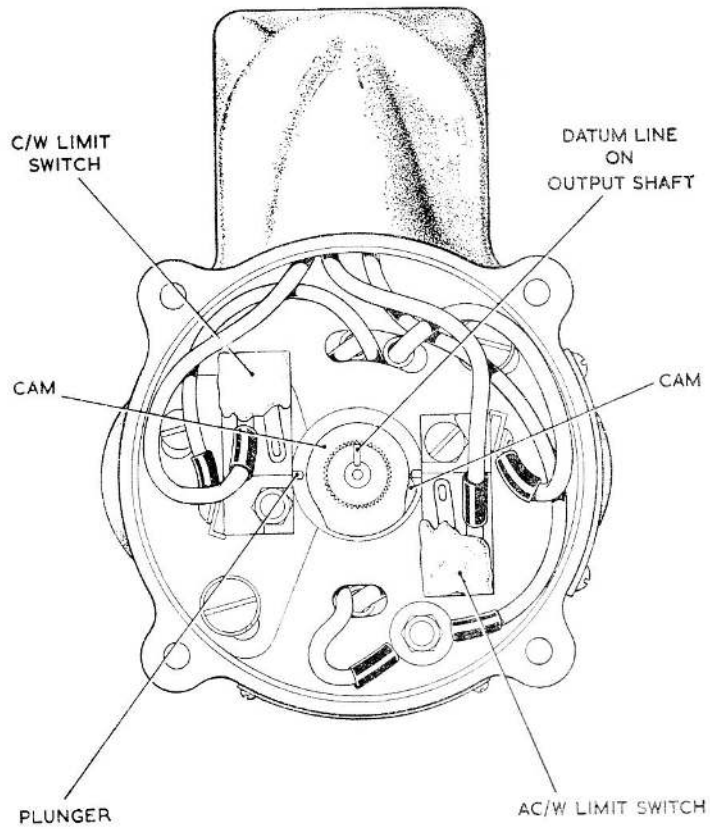

Fig. 2. Limit switches and cams

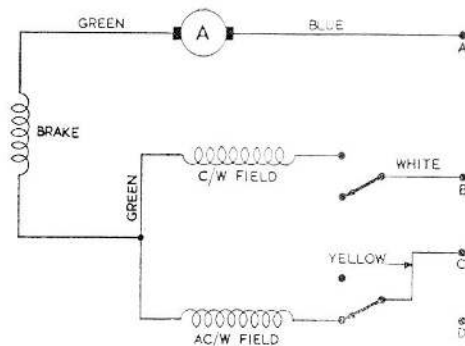

Fig. 3. Diagram of internal connections

**RESTRICTED**

## Appendix 8

### ACTUATOR, ROTAX, TYPE C5521

#### LEADING PARTICULARS

<b>Actuator, Type C5521</b>	.....	.....	.....	.....	.....	<i>Ref. No. 5W/2837</i>
Normal voltage	.....	.....	.....	.....	.....	28 volts d.c.
Operating voltage range	.....	.....	.....	.....	.....	18-29 volts d.c.
◀ Current at normal load	.....	.....	.....	.....	.....	1.65 amp. ▶
Speed of rotation at normal load	.....	.....	.....	.....	.....	13 sec. per 90 deg.
Normal load	.....	.....	.....	.....	.....	30 lb. in.
Maximum load	.....	.....	.....	.....	.....	60 lb. in.
Maximum static load	.....	.....	.....	.....	.....	90 lb. in.
Ambient temperature range	.....	.....	.....	.....	.....	-40 deg. C. to +90 deg. C.
Rating	.....	.....	.....	.....	.....	<i>Intermittent</i>
Ratio of gear train	.....	.....	.....	.....	.....	21,006:27 : 1
Brush grade	.....	.....	.....	.....	.....	<i>E.G. 14 (Ref. No. 5W/643)</i>
Brush length (new)	.....	.....	.....	.....	.....	0.226 in.
Minimum brush length	.....	.....	.....	.....	.....	0.125 in.
Brush spring pressure	.....	.....	.....	.....	.....	2.5 oz. (71 gm.)
◀ Commutator diameter (new)	.....	.....	.....	.....	.....	0.350-0.352 in. ▶
Commutator diameter (minimum permissible)	.....	.....	.....	.....	.....	0.335 in.
Operational ceiling	.....	.....	.....	.....	.....	50,000 ft.
Overall dimensions—						
Length	.....	.....	.....	.....	.....	6.109 in.
Width	.....	.....	.....	.....	.....	2.362 in.
Height	.....	.....	.....	.....	.....	3.265 in.
Weight	.....	.....	.....	.....	.....	1 lb. 2 oz.

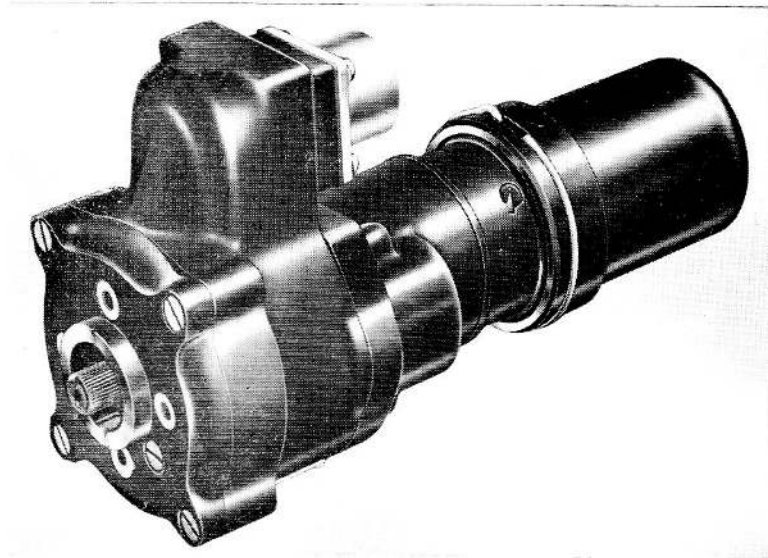

Fig. 1. Type C5521 actuator

RESTRICTED

1. This actuator (*fig. 1*) is generally similar to that described in the main chapter. The rotary movement of the output shaft is limited to 180 deg. by the two internal limit switches; on the external face of the end plate is a spigot marked by two sawcuts, which indicate the extremities of travel of a datum line cut in the end of the output shaft.

2. The gearbox contains a ten-stage spur gear train assembled about three lay shafts, of which two (outer) are fixed. The third (central) lay shaft is secured to pinion integral with the output shaft.

3. Electrical connection is made by a four-pole plug (Ref. No. 5X/6006), which is mounted above the actuator but in line with its axis. The internal connections are as shown in the circuit diagram in *fig. 2*.

4. The actuator is provided with four mounting holes in the drive end plate. They are tapped 2 B.A. to a depth of 0.218 in., and are equispaced on a 1.25 in. P.C.D.

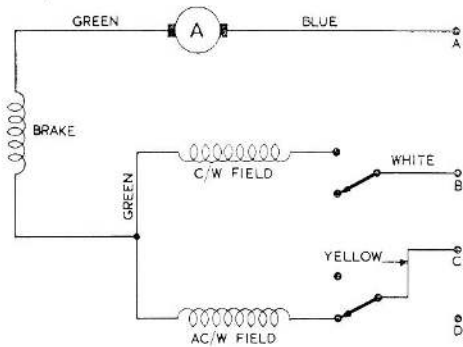

**Fig. 2.** Diagram of internal connections

Appendix 9

ACTUATOR, ROTAX, TYPE C5523/2

LEADING PARTICULARS

<b>Actuator, Type C5523/2</b> ... ..	<b>Ref. No. 5W/2717</b>
Normal voltage ... ..	28 volts d.c.
Operating voltage range ... ..	18 — 29 volts d.c.
Current at normal load ... ..	1·8 amp.
Speed of rotation at normal load ... ..	2·25 sec. per 90 deg.
Normal load ... ..	30 lb. in.
Maximum load ... ..	60 lb. in.
Maximum static load ... ..	90 lb. in.
Ambient temperature range ... ..	-40 deg. C. to +90 deg. C.
Rating ... ..	Intermittent
Ratio of gear train ... ..	2,334: 1
Brush grade ... ..	E.G. 14 (Ref. No. 5W/643)
Brush length (new) ... ..	0·226 in.
Minimum brush length ... ..	0·125 in.
Brush spring pressure ... ..	2·5 oz. (71 gm.)
Operational ceiling ... ..	50,000 ft.
Overall dimensions—	
Length ... ..	6·081 in.
Width ... ..	2·362 in.
Height ... ..	2·315 in.
Weight ... ..	1 lb. 5 oz.

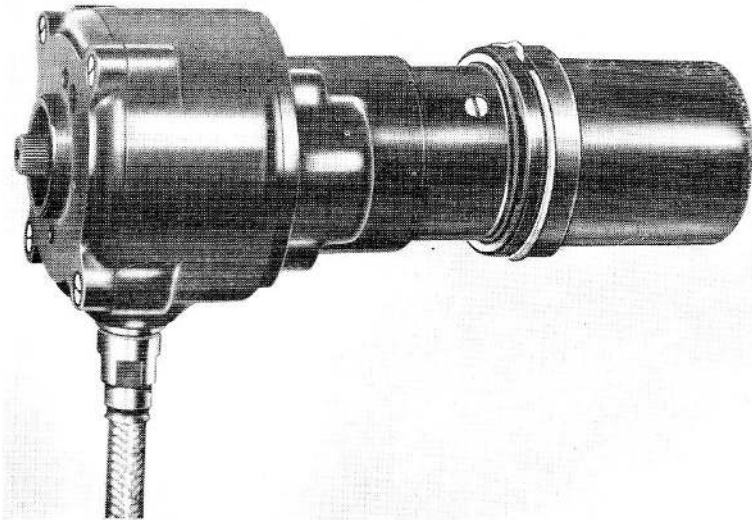

Fig. 1. Type C5523/2 actuator

RESTRICTED

1. This actuator (*fig. 1*) is generally similar to that described in the main chapter. The rotary movement of the output shaft is limited to 90 deg. by the two internal limit switches.

2. The gearbox has an eight-stage single spur gear train arranged in one central and two outer lay shafts; the final stage has two gears, one on each outer lay shaft, which drive the output shaft in tandem.

3. Electrical connection is made by a 35 in. length of Quinpremet 6 cable which is taken through a gland entry screwed to the housing; the cable ends in a 5-pole socket (Ref. No. 5X/6019, superseded by 5X/6376/B). The internal connections are as shown in the circuit diagram in *fig. 2*.

4. The actuator is provided with four mounting holes in the drive end frame. They are tapped 4 B.A. to a depth of 0.218 in., and are equispaced on a P.C.D. of 1.25 in.

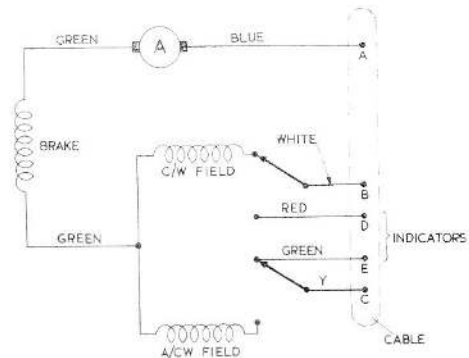

**Fig. 2.** Diagram of internal connections

**Appendix 10**

**ACTUATOR, ROTAX, TYPE C5524/2**

**LEADING PARTICULARS**

<b>Actuator, Type C5524/2</b>	...	...	...	...	...	...	...	...	Ref. No. 5W/4705
Normal voltage	...	...	...	...	...	...	...	...	28 volts d.c.
Operating voltage range	...	...	...	...	...	...	...	...	18 — 29 volts d.c.
Current at normal load	...	...	...	...	...	...	...	...	2.25 amp.
Speed of rotation at normal load	...	...	...	...	...	...	...	...	1.5 sec. per 90 deg.
Normal load	...	...	...	...	...	...	...	...	15 lb. in.
Maximum load	...	...	...	...	...	...	...	...	30 lb. in.
Maximum static load	...	...	...	...	...	...	...	...	90 lb. in.
Ambient temperature range	...	...	...	...	...	...	...	...	-50 deg. C to +120 deg. C.
Rating	...	...	...	...	...	...	...	...	Intermittent
Ratio of gear train	...	...	...	...	...	...	...	...	1,015.8: 1
Brush grade	...	...	...	...	...	...	...	...	E.G. 14 (Ref. No. 5W/643)
Brush length (new)	...	...	...	...	...	...	...	...	0.226 in.
Minimum brush length	...	...	...	...	...	...	...	...	0.125 in.
Brush spring pressure	...	...	...	...	...	...	...	...	2.5 oz. (71 gm.)
Commutator diameter (new)	...	...	...	...	...	...	...	...	0.350-0.352 in.
Commutator diameter (minimum permissible)	...	...	...	...	...	...	...	...	0.335 in.
Overall dimensions—									
Length	...	...	...	...	...	...	...	...	6.593 in.
Width	...	...	...	...	...	...	...	...	2.362 in.
Height	...	...	...	...	...	...	...	...	3.499 in.
Weight	...	...	...	...	...	...	...	...	1 lb. 4 oz.

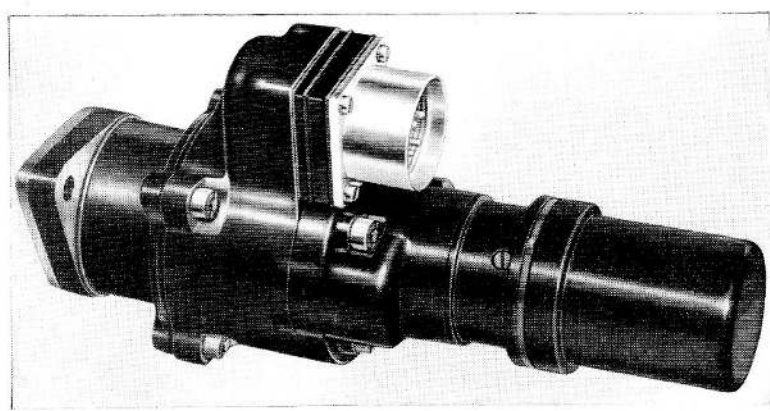

**Fig. 1. Type C5524/2 actuator**

**RESTRICTED**

1. This actuator (*fig. 1*) is generally similar to that described in the main chapter. The rotary movement of the output shaft is limited to 90 deg. by the two internal limit switches.

2. Electrical connection is made by a four-pole plug (Ref. No. 5X/6006), which is mounted above the actuator but in line with its axis. The internal connections are as shown in the circuit diagram in *fig. 2*.

3. Two holes 0.196 in dia. on a 2.25 in. P.C.D. are provided in the flange of the drive end housing for mounting purposes. The internal register of the drive end housing for locating the unit is 1.593 in. dia., and the flange thickness is 0.312 in. The

drive end of the output shaft has 36 serrations in a 0.312 in. nominal diameter.

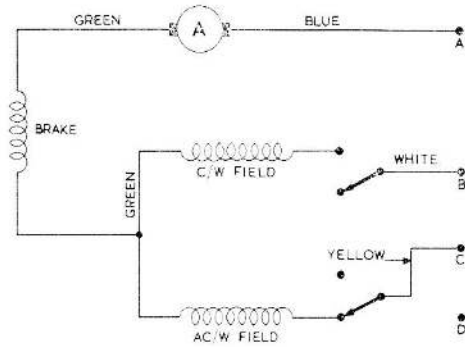

**Fig. 2.** Diagram of internal connections

## Appendix 11

## ACTUATOR, ROTAX, TYPE C5527

## LEADING PARTICULARS

<b>Actuator, Type C5527</b> .....	<b>Ref. No. 5W/</b>
<i>Normal voltage</i> .....	28 volts d.c.
<i>Operating voltage range</i> .....	18—29 volts d.c.
<i>Current at normal load</i> .....	1·8 amp.
<i>Speed of rotation at normal load</i> .....	2·25 sec. per 90 deg.
<i>Normal load</i> .....	30 lb. in.
<i>Maximum load</i> .....	60 lb. in.
<i>Maximum static load</i> .....	90 lb. in.
<i>Ambient temperature range</i> .....	−40 deg. C. to +90 deg. C.
<i>Rating</i> .....	Intermittent
<i>Ratio of gear train</i> .....	2,334:1
<i>Brush grade</i> .....	E.G. 14 (Ref. No. 5W/643)
<i>Brush length (new)</i> .....	0·226 in.
<i>Minimum brush length</i> .....	0·125 in.
<i>Brush spring pressure</i> .....	2·5 oz. (71 gm.)
<i>Operational ceiling</i> .....	50,000 ft.
<i>Overall dimensions—</i>	
<i>Length</i> .....	6·081 in.
<i>Width</i> .....	2·362 in.
<i>Height</i> .....	2·315 in.
<i>Weight</i> .....	1 lb. 2 oz.

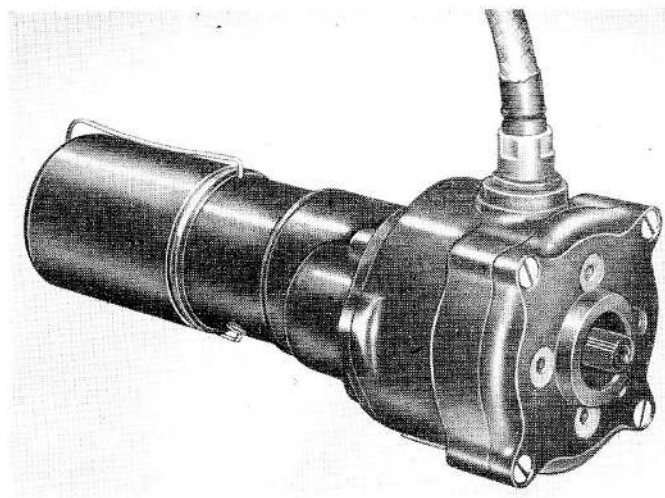

Fig. 1. Type C5527 actuator

RESTRICTED

1. This actuator (*fig. 1*) is generally similar to that described in the main chapter, with the exception that no limit switches are fitted. The output shaft travel is controlled by external switches, and it is important that these should operate efficiently to avoid overrunning of the actuator.

2. The gearbox has an eight-stage single spur gear train arranged on one central and two outer lay shafts; the final stage has two gears which drive the output shaft in tandem.

3. Electrical connection is made by a 6 ft. length of Triprenmet 6 cable, which is taken through a gland entry secured to the housing. The internal connections are as shown in *fig. 2*.

4. The actuator is provided with four

mounting holes in the drive end frame. They are tapped 4 B.A. to a depth of 0.218 in., and are equispaced on a 1.25 in. P.C.D. The output shaft has 36 serrations cut into a 0.312 in. nominal diameter.

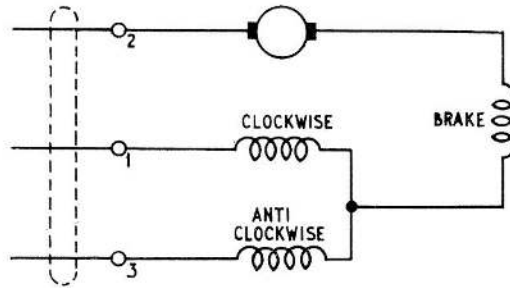

**Fig. 2. Circuit diagram**

## Appendix 12

### ACTUATOR, ROTAX, TYPE C5530/1

#### LEADING PARTICULARS

<b>Actuator, Type C5530/1</b> ... ..	<b>Ref. No. 5W/5007</b>
<i>Normal voltage</i> ... ..	28 volts d.c.
<i>Operating voltage range</i> ... ..	18 — 29 volts d.c.
<i>Current at normal load</i> ... ..	2.25 amp.
<i>Speed of rotation at normal load</i> ... ..	1.5 sec. per 90 deg.
<i>Normal load</i> ... ..	15 lb. in.
<i>Maximum load</i> ... ..	30 lb. in.
<i>Maximum static load</i> ... ..	90 lb. in.
<i>Ambient temperature range</i> ... ..	— 50 deg. C. to +120 deg. C.
<i>Rating</i> ... ..	Intermittent
<i>Ratio of gear train</i> ... ..	1.015:8:1
<i>Brush grade</i> ... ..	E.G. 14 (Ref. No. 5W/643)
<i>Brush length (new)</i> ... ..	0.226 in.
<i>Minimum brush length</i> ... ..	0.125 in.
<i>Brush spring pressure</i> ... ..	2.5 oz. (71 gm.)
<i>Overall dimensions—</i>	
<i>Length</i> ... ..	6.593 in.
<i>Width</i> ... ..	2.362 in.
<i>Height</i> ... ..	3.499 in.
<i>Weight</i> ... ..	1 lb. 7 oz.

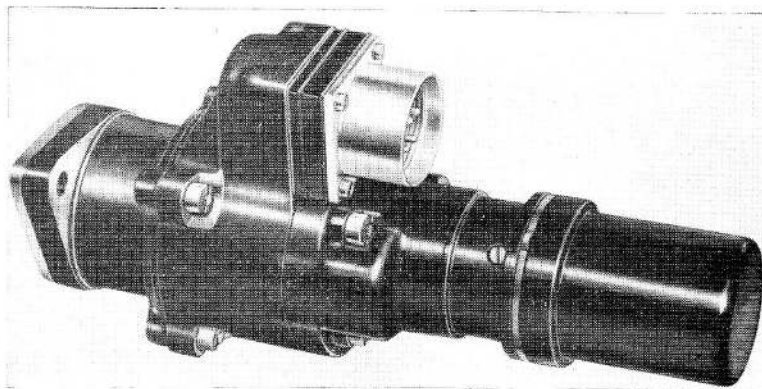

Fig. 1. Type C5530/1 actuator

RESTRICTED

1. This actuator (*fig. 1*) is generally similar to that described in the main chapter. The rotary movement of the output shaft is limited to 90 deg. by the two internal limit switches.

2. Electrical connection is made by a four-pole plug (Ref. No. 5X/6006), which is mounted above the actuator but in line with its axis. The internal connections are as shown in the circuit diagram in *fig. 2*.

3. Two holes 0.196 in. dia. on a 2.25 in. P.C.D. are provided in the flange of the drive end housing for mounting purposes. The drive end housing locating register is 1.593 in. dia., the thickness of the locating flange being 0.312 in. The drive end of the output shaft has 36 serrations in a 0.312 in.

nominal diameter; a mating serrated coupling is fitted to the drive end of the output shaft is provided with this actuator.

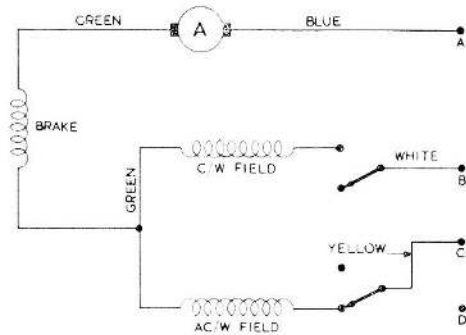

**Fig. 2. Diagram of internal connections**

## Appendix 13

### ACTUATOR, ROTAX, TYPE C5519

#### LEADING PARTICULARS

<b>Actuator, Type C5519</b> ... ..	Ref. No. 5W/880
Normal voltage ... ..	28V d.c.
Operating voltage range ... ..	18-29V d.c.
Current at normal load ... ..	1.65 amp.
Speed of rotation at normal load ... ..	13 sec. per 90 deg.
Angular variation of stop positions ... ..	±1 deg.
Normal load ... ..	30 lb. in.
Maximum load ... ..	60 lb. in.
Maximum static load ... ..	90 lb. in.
Ambient temperature range ... ..	-40 deg. C. to +90 deg. C.
Rating ... ..	Intermittent (2 cycles)
Ratio of gear train ... ..	21,006:27:1
Brush grade ... ..	E.G. 14 (Ref. No. 5W/643)
Brush length (new) ... ..	0.226 in.
Brush length (minimum permissible) ... ..	0.125 in.
Brush spring pressure ... ..	2.5 oz. (71 gm.)
Commutator diameter (new) ... ..	0.350-0.352 in.
Commutator diameter (minimum permissible) ... ..	0.335 in.
Overall dimensions—	
Length ... ..	6.109 in.
Width ... ..	2.362 in.
Height ... ..	3.265 in.
Weight ... ..	1 lb. 4 oz.

1. The C5519 actuator is generally similar to that described in the main chapter, except that rotary movement of the output shaft is limited to 90 deg. by two internal limit switches. A machined line on the end face of the serrated output shaft indicates the extreme clockwise and anti-clockwise travel between two machined lines on the spigot end face of the supporting end plate housing.

2. The gearbox contains a ten-stage spur gear train assembled about three layshafts of which two (outer) are fixed. The output shaft has the third central layshaft embodied as an integral part which projects from the gear end of the shaft and carries part of the ten stage gear train.

3. Electrical connection is made by a four pole plug (Ref. No. 5X/6006) which is mounted above the actuator, but in line with the horizontal axis. The internal connections

are as shown in the circuit diagram in fig. 1.

4. The actuator is provided with four mounting holes in the drive end plate. They are tapped 2 B.A. to a depth of 0.218 in., and equi-spaced on a 1.250 in. P.C.D.

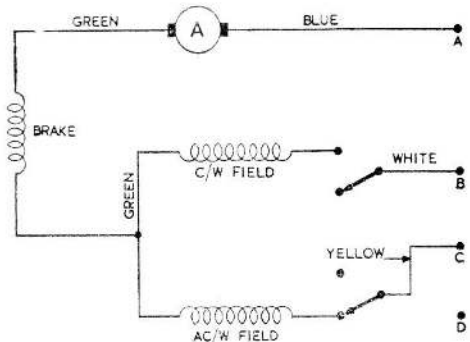

Fig. 1. Diagram of internal connections

## Appendix 14

### ACTUATOR, ROTAX, TYPE C5536

#### LEADING PARTICULARS

<b>Actuator, Type C5536</b>	...	...	...	...	...	...	...	...	Ref. No. 5W/4694
Normal voltage	...	...	...	...	...	...	...	...	28V d.c.
Operating voltage range	...	...	...	...	...	...	...	...	18-28.5V d.c.
Current at normal load	...	...	...	...	...	...	...	...	2.25 amp.
Speed of rotation at normal load	...	...	...	...	...	...	...	...	1.0 sec. per 90 deg.
Angular variation of stop positions	...	...	...	...	...	...	...	...	±2 deg.
Normal load	...	...	...	...	...	...	...	...	15 lb. in.
Maximum load	...	...	...	...	...	...	...	...	30 lb. in.
Maximum static load	...	...	...	...	...	...	...	...	90 lb. in.
Ambient temperature range	...	...	...	...	...	...	...	...	-50 deg. C. to +120 deg. C. (max.)
Rating	...	...	...	...	...	...	...	...	Intermittent
Ratio of gear train	...	...	...	...	...	...	...	...	1,015.8:1
Brush grade	...	...	...	...	...	...	...	...	E.G. 14 (Ref. No. 5W/643)
Brush length (new)	...	...	...	...	...	...	...	...	0.226 in.
Brush length (minimum permissible)	...	...	...	...	...	...	...	...	0.125 in.
Brush spring pressure	...	...	...	...	...	...	...	...	2.5 oz. (71 gm.)
Armature diameter (new)	...	...	...	...	...	...	...	...	0.350-0.352 in.
Armature diameter (minimum permissible)	...	...	...	...	...	...	...	...	0.335 in.
<b>Overall dimensions—</b>									
Length	...	...	...	...	...	...	...	...	6.593 in.
Width	...	...	...	...	...	...	...	...	2.362 in.
Height	...	...	...	...	...	...	...	...	3.265 in.
Weight	...	...	...	...	...	...	...	...	1 lb. 4 oz.

1. The C5536 actuator is generally similar to that described in the main chapter except that rotary movement of the output shaft is limited to 90 deg.; the gearbox has an eight-stage single spur gear train arranged in one central and two outer layshafts; the final stage has two gears, one on each outer layshaft, which drive the output shaft in tandem.

2. The adapter housing has been moved through 60 deg. from the vertical axis in an anti-clockwise direction, and incorporates the lengthened serrated output shaft. The C5536 actuator is identical to the C5524/2 actuator in the series, other than the adap-

ter housing being moved through 60 deg. in an anti-clockwise direction.

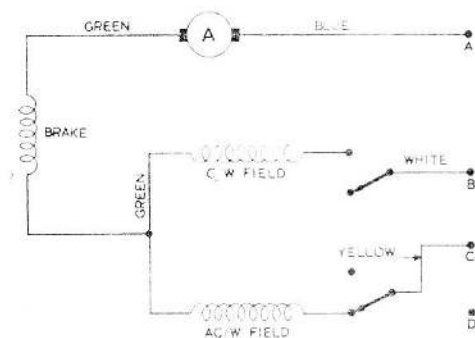

**Fig. 1. Diagram of internal connections**

**RESTRICTED**



travel, and closed over 80 deg. approx. The full travel is 90 deg. in an anti clockwise and clockwise direction of rotation.

6. The nine pole Plessey plug (Ref. No. 5X/6036) is fitted with aluminium gaskets and rubber 'O' rings on each pole to effect complete sealing for anti-resistant electrical fitting. The switch block springs, output shaft, and associated cams are also corrosion resistant treated.

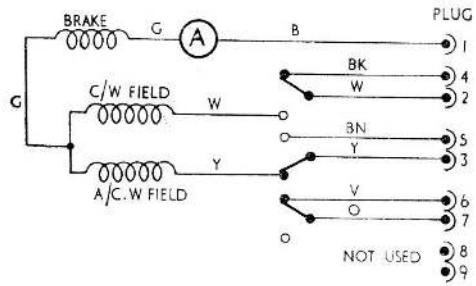

Fig. 1. Diagram of internal connections

This file was downloaded  
from the RTFM Library.

Link: [www.scottbouch.com/rtfm](http://www.scottbouch.com/rtfm)

Please see site for usage terms,  
and more aircraft documents.

