

Chapter 22

MOTOR GEAR ASSEMBLY, TYPE KLAXON LRG

LIST OF CONTENTS

	Para.		Para.
Introduction	1	Operation.....	14
Description	4	Installation	
Motor	8	Adjustments.....	17
Gears	9	Servicing	20
Limiting switches	13	Technical data	23

LIST OF ILLUSTRATIONS

	Fig.		Fig.
Gearbox with cover removed	1	Wiring diagram	3
Switch control, cover removed	2		

Introduction

1. The motor gear assembly, Type Klaxon LRG (Stores Ref. 5UD/3287), is designed as an electrical remote control for operating the oil cooler shutters of aircraft engines.

2. It consists of a small motor (*fig. 1*) suitably geared to control the oil cooler shutters by means of a crank and linkage, the motor being operated by a switch on the engine instrument panel or automatically by means of a thermostat in the oiling system.

3. An indicator, which is operated by a transmitter of the Desynn type and which is adjacent to the manual operating switch on the instrument panel, records the position of the cooler shutters at all openings. At the motor end, the transmitter is connected mechanically by linkage to a crank fitted to the same shaft that carries the crank operating the cooler shutters.

DESCRIPTION

4. The motor gear assembly as shown in *fig. 1* consists of a small 24-volt motor attached to the gearbox which operates the quadrant, through a worm, worm wheel, and reduction wheels.

5. Incorporated in the worm wheel is an adjustable clutch, and attached to the

motor there is a metal cup known as a diverter pot which houses a diverter coil, the latter acting as a dynamic brake.

6. On the reverse side of the gearbox under a Bakelite cover is an adjustable limiting switch mechanism. *Fig. 2* illustrates this mechanism, and the "fully open" limiting switch, the "fully closed" limiting switch, and the operating arm are clearly shown. Attached to the side of the gearbox is a 4-pole plug for connection to the electric supply and controlling switch.

7. Attached to, and integral with, the quadrant is an operating arm or crank and riveted to the quadrant shaft is another small crank. The former crank is linked to the oil cooler shutter and the latter to the transmitter of the oil shutter indicator.

Motor

8. The motor is a two-pole split series wound machine having one field winding on each pole. One field gives clockwise rotation and the other anti-clockwise. Across the armature is connected a diverter coil or dynamic brake, the coil itself being housed in a metal pot fixed to the outside of the Bakelite yoke casing. The armature shaft is provided with ball bearings at each end, and a single ball at the extreme end of the shaft at the commutator end acts as

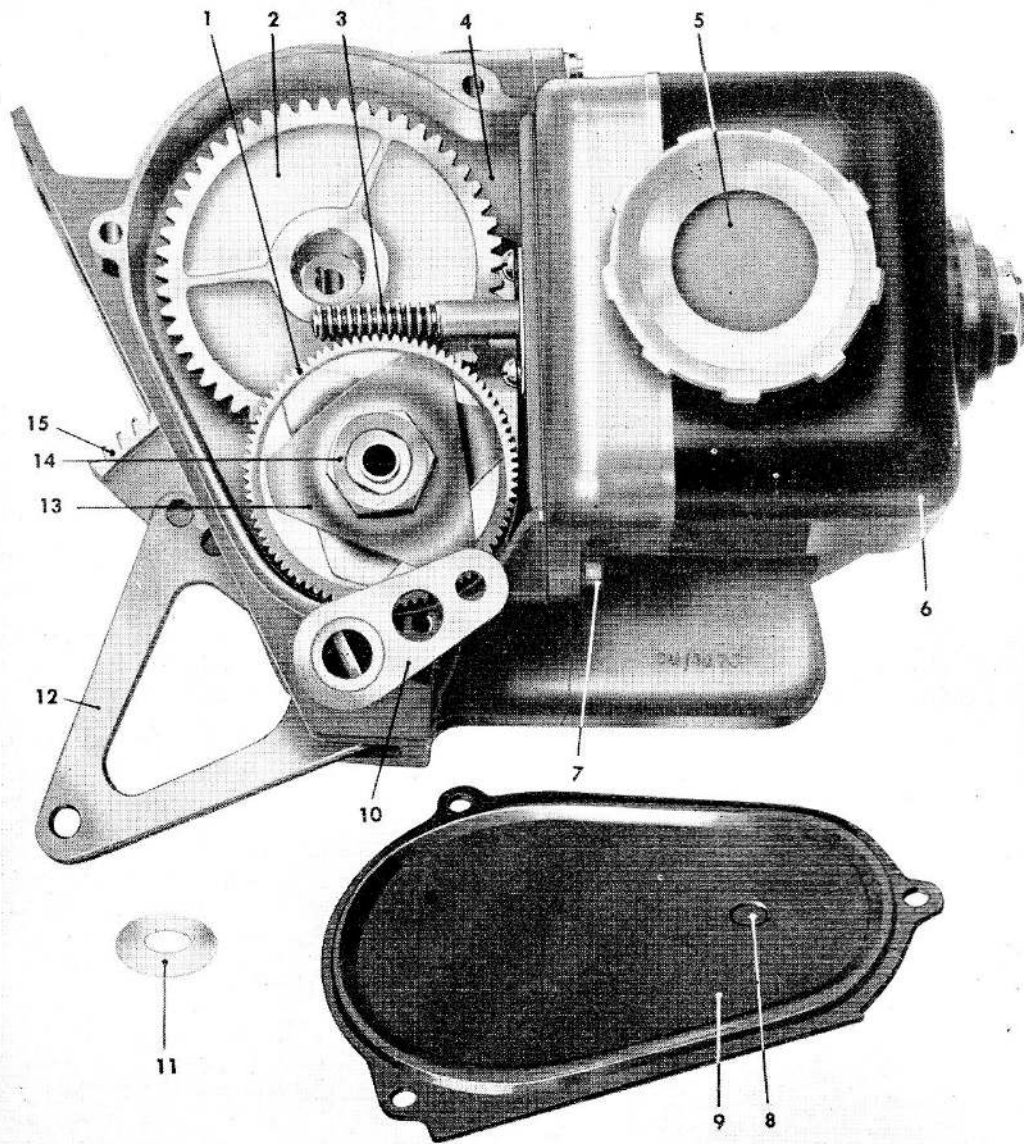

- | | |
|---------------------------------|-----------------------------------|
| 1 CLUTCH WHEEL ASSEMBLY | 9 GEARBOX COVER |
| 2 INTERMEDIATE GEAR WHEEL | 10 INDICATOR ARM |
| 3 WORM DRIVE | 11 THRUST WASHER |
| 4 GEARBOX | 12 SHUTTER OPERATING ARM OR CRANK |
| 5 DIVERTER POT | 13 CLUTCH SPRING |
| 6 MOTOR | 14 CLUTCH ADJUSTING NUT |
| 7 MOTOR FIXING SCREW | 15 QUADRANT |
| 8 RECESS TO ACCEPT CLUTCH SHAFT | |

Fig. 1. Gearbox with cover removed

RESTRICTED

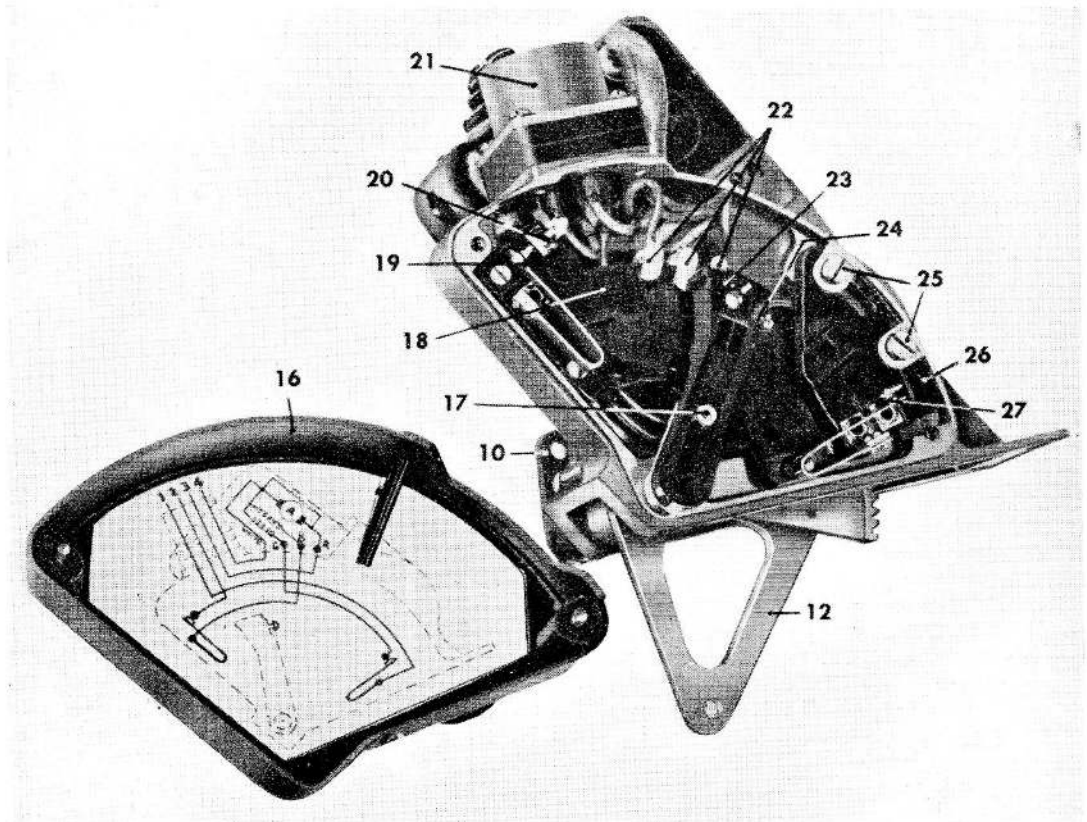

- | | |
|---|--|
| 10 INDICATOR ARM | 21 4-POLE PLUG |
| 12 SHUTTER OPERATING ARM OR CRANK | 22 TERMINAL TAGS |
| 16 CONTACT COVER | 23 SWITCH OPERATING ARM |
| 17 SWITCH OPERATING ARM FIXING NUT | 24 "FULLY OPEN" FINE ADJUSTMENT STUD |
| 18 "FULLY CLOSED" SWITCH MOULDED INSERT | 25 "FULLY OPEN" COARSE ADJUSTMENT SCREWS |
| 19 "FULLY CLOSED" CONTACTS | 26 "FULLY OPEN" SWITCH MOULDED INSERT |
| 20 "FULLY CLOSED" FINE ADJUSTMENT CONTACT | 27 "FULLY OPEN" CONTACTS |

Fig. 2. Switch control, cover removed

a thrust bearing against a steel disc. The latter is adjustable by means of a screwed bush and when adjusted to the correct clearance, the bush is locked in position by a dished washer. The driving end frame is of metal but the yoke casing and commutator end frame, which are integral, is of bakelite. The yoke complete with the field coils is a sliding fit in the yoke casing and is secured by two studs and nuts. Brass brush-holders are held in the Bakelite end frame by means of grub screws and the brushes and bush springs are secured in

the holders by brass brush caps. Phosphor-bronze coil springs, accommodated in grooves in the holder are used to connect the windings to the brushes. The brush connections and those of the field coils pass through the Bakelite yoke casing, a rubber grommet preventing damage to the insulation of the leads. The diverter coil leads pass from the brush-holder connections to the diverter coil through the yoke casing directly under the diverter coil pot. The driving end shaft has a worm drive machined on it.

Gears

9. The worm drive acts on a Bakelized fabric helical or worm wheel (*fig. 1*). To this worm wheel is assembled a friction clutch through which the gears are driven. The clutch is adjustable by means of a nut, the latter being drilled and tapped to accept a grub screw for locking purposes. The clutch is set to a pre-determined torque, and if this torque is exceeded the clutch slips, allowing the motor to run on, thus preventing any damage to the motor or the mechanical moving parts of the installation.

10. The ratio of the worm and worm wheel is 84 to 1. To the same hub as the worm wheel is fitted a chrome steel pinion having 14 teeth. The worm wheel and pinion revolve on a fixed shaft and are kept in place by a steel thrust washer bearing against the gearbox cover plate, the latter being dished outwards to accept the end of the hub of the shaft. The worm wheel pinion engages with an intermediate gear wheel having 52 teeth. The intermediate gear wheel has a pinion of 14 teeth on its hub and is mounted on a fixed shaft.

11. The pinion of the intermediate gear drives directly on to a quadrant having the equivalent of 110 teeth for a full circle. This gives an overall ratio of approximately 2,450 to 1 between the motor and quadrant. The gearing and shafts are housed in a light alloy casting in which the motor is attached by two cheese headed screws.

12. The quadrant has an operating arm or crank riveted to it to which the oil cooler shutters are linked. Attached to the quadrant shaft is another operating arm or crank for operating the indicator on the engine instrument panel through the medium of the transmitter. Both the quadrant and indicator operating crank are fitted to a common shaft by means of splined rivets; set screws being provided to fix the relative positions on the shaft whilst the shaft is being drilled and the splined rivets fitted.

Limiting switches

13. Under the Bakelite cover on the side opposite the gears are housed the limiting

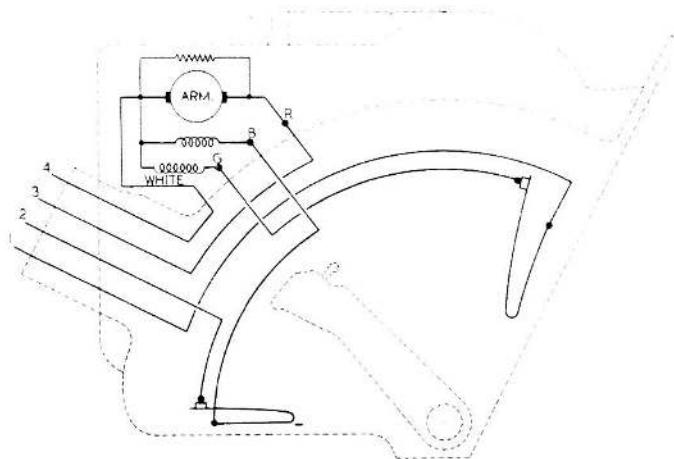

Fig. 3. Wiring diagram

switches (*fig. 2*). The moulded operating arm is attached to a short metal arm, this being a part of, and integral with, the shaft carrying the quadrant. It is attached by means of a small screw, nut and spring washer. Moulded inserts carry the "fully open" limit switch and the "fully closed" limit switch respectively. The "fully open" switch and moulded insert is coarsely adjustable by means of two screws. Fine adjustment is obtained by varying the length of the small stud on the moulded operating arm for the open setting and by an adjustable contact for the closed position. On the moulded insert carrying the closed switch there are three tag terminals to which are soldered the incoming leads from the motor and outgoing leads to the limiting switches and plug. These are again shown in the wiring diagram (*fig. 3*) at G, B and R. A 4-pole plug for connection to the electric supply and controlling switch is fitted to the gear case by means of four cheese headed screws and spring washers.

OPERATION

14. When the control switch is operated in the "open" or "closed" positions, the motor rotates clockwise or anti-clockwise respectively, operating the cooler shutters accordingly. If the shutters are required to be "fully open" or "fully closed" the switch is left in the desired position and the appropriate limiting switch, which is in series with the main switch, is opened by means of the operating arm coming in contact with it at the end of its travel, thus breaking the circuit. The indicator arm or crank on the quadrant staff operates the transmitter, the latter transmitting its

motion electrically to the visual indicator on the instrument panel. The control switch can be manually placed in the OFF position at any point of opening, and the cooler shutters will remain in that position.

15. To avoid the inertia of the motor running the mechanism past the desired opening after the current is switched off, the diverter coil is connected across the armature and acts as a brake. The revolving armature, due to residual magnetism, generates an electric current and the diverter coil acts as a load on the "generator" and rapidly decelerates the armature. Across the armature is also connected an indicator lamp, situated adjacent to the control switch on the instrument panel, and when the motor is running, the lamp automatically lights up. Should one of the limiting switches fail to operate at the end of the travel, the connecting mechanism is prevented from strain and the motor from stopping by slipping of the clutch incorporated in the worm wheel. If this condition obtains, the indicator lamp on the instrument will show the shutters fully open or fully closed, whilst the lamp will indicate that the motor is still running.

16. On some aircraft the control of the cooler shutters is not manual but is carried out by means of a thermostat in the oil circuit which keeps the oil temperature approximately constant.

INSTALLATION

Adjustments

17. When the control unit has been fitted to the aircraft by means of the screws and bolts provided and after the oil cooler shutter linkage, the indicator linkage, and electrical connections are made, adjustment must be carried out.

18. It is assumed that the linkage to the cooler shutters has been adjusted to the shut position with the control arm (*fig. 2*) just braking the limit switch. Operate the unit electrically to the "fully open" position and when the shutters are fully opened, switch off if this has not already been done automatically by the open limit switch. Roughly adjust the latter by loosening the two screws and sliding the bakelite insert to the approximate position and securely tightening the screws. Fine

adjustment for the "fully open" and "fully closed" position must then be made by use of the adjusting screws.

19. Tests should be carried out by operating the unit to the "fully opened" and "fully closed" positions using the normal switch to switch on, allowing the motor to switch off automatically by means of the limiting switches, taking into account the slight overrun of the motor.

SERVICING

20. The unit, as a whole, requires very little attention. Periodically check the contacts and contact springs of the limit switches for serviceability. The contacts may be cleaned with fine glass paper or lightly with a fine file. The complete limit switch and Bakelite insert must be renewed if a fault occurs; no attempt to remove the switches from the Bakelite should be made.

21. Inspect the gears for faults and add a little grease XG-275 (Stores Ref. 34B/9105058) if necessary. To inspect the gears, the cover must be removed. To do this the unit should be operated until the hole in the indicator crank or arm is opposite the gearbox cover screw and stopped in that position by manually switching off.

22. The motor bearings are packed with grease when received and no attention is required. The complete motor has to be dismantled for the re-lubrication of the bearings and this must only be carried out by a Maintenance Unit.

Technical data

23. The following are technical details:—

- (1) Normal operating torque available is 150-170 lb./in. pre-set by the friction clutch incorporated in the worm wheel. This clutch is adjusted by the manufacturer and must not be altered except in an emergency, when adjustment should be carried out in the following manner. Remove the complete motor and gearbox unit from the aircraft and rig it up in a bench vice with the shutter operating arm or crank horizontal and clear of the bench, to enable weights to be suspended from it.

unlock the adjusting nut (*fig. 1*) by unscrewing the grub screw, and tighten the adjusting nut fairly tightly. Suspend a weight of 80 lb. in the linkage hole of the shutter operating arm and gradually slacken off the adjusting nut until the clutch shows signs of slipping and the weight starts to descend. The adjustment is correct when the clutch just holds a weight of 80 lb.

- (2) The radius of the shutter operating arm is 2 in.
- (3) The available radial movement of the shutter operating arm is approximately 80 degrees.
- (4) The 4-pole plug is marked internally on the Bakelite 1, 2, 3 and 4, and the connections are "open," "close," "common wire" and "indicator lamp" respectively.

This file was downloaded
from the RTFM Library.

Link: www.scottbouch.com/rtfm

Please see site for usage terms,
and more aircraft documents.

