



<i>Intermediate</i> ... ..	83 deg.
<i>Time taken for travel CZ64581</i>	
<i>To 140 deg. full open position</i> ... ..	2 sec.
<i>To 70 deg. mid-position</i> ... ..	1 sec.
<i>Time taken for travel CZ64581A</i>	
<i>To 166 deg. full open position</i> ... ..	2.33 sec.
<i>To 83 deg. mid-position</i> ... ..	1.33 sec.
<i>Output of motor</i> ... ..	0.017 hp
<i>at a speed of</i> ... ..	17.000 rev. min.
<i>Rating of motor</i> ... ..	1.5 min.
<i>Weight of actuator</i> ... ..	3.25 lb.
<i>Motor Type C1606B/1</i> ... ..	Ref. No. 5W/1065

### LIST OF TABLES

<i>Table</i>		<i>Table</i>	
<i>Travel CZ64581</i> ... ..	1	<i>Tools</i> ... ..	4
<i>Travel CZ64581/A</i> ... ..	2	<i>Load test figures</i> ... ..	5
<i>Indicator and warning lights</i> ... ..	3	<i>Fits and clearances</i> ... ..	6

### Introduction

1. The three-position Panther actuators described in this chapter are designed to provide remotely controlled rotary operation of valves or similar components. Actuators of this type enable the valve component to be opened to a mid-position, or other pre-determined setting if required, and be returned direct to the closed position. Alternatively, the valve may be opened to the fully-opened position from the mid-position, depending on operating requirements.

2. Actuators CZ64581 (Ref. No. 5W/308) and CZ64581A (Ref. No. 5W/4978) differ only in the range of angular travel, the differences being achieved by varying the settings of cam-operated limit switches.

### DESCRIPTION

#### General

3. The actuator's (fig. 1) main external features are a switch housing, actuator body and motor cover. The switch housing and actuator body are secured by two shouldered studs, the protruding ends of which are used for mounting the unit. The studs pass through the flange plate blanking the end of the switch housing, through the housing to screw into the actuator body, where they

are retained by grub-screws. The flange plate is spigot-located to the switch housing and locked by a screw. The actuator body is spigot- and dowel-located to the switch housing, whilst the motor cover is secured to the other side of the actuator body by a cover retaining nut, locked by a screw.

4. Motive power to rotate the actuator is provided by a small motor, the drive being transmitted through a compound reduction gear train to the output shaft and drive pin. The drive pin engages with the dog shaft of the actuated component.

5. The motor is of the split-field, series wound, reversible type, incorporating an electro-magnetic brake which rapidly stops the motor when the supply is interrupted or switched off, and effectively prevents over-run of the armature shaft. It is attached to a spigot plate interposed between the motor housing and actuator body by means of positioning studs and 4 BA nuts and washers. The motor Type C1606B/1 (Ref. No. 5W/1065) is fully described in A.P. 4343D, Vol. 1, Book 4, Sect. 20.

6. A terminal block located in the spigot plate accommodates the leads from the limit switches to the motor. In addition, it facilitates the removal of the motor from the main actuator assembly.

**RESTRICTED**

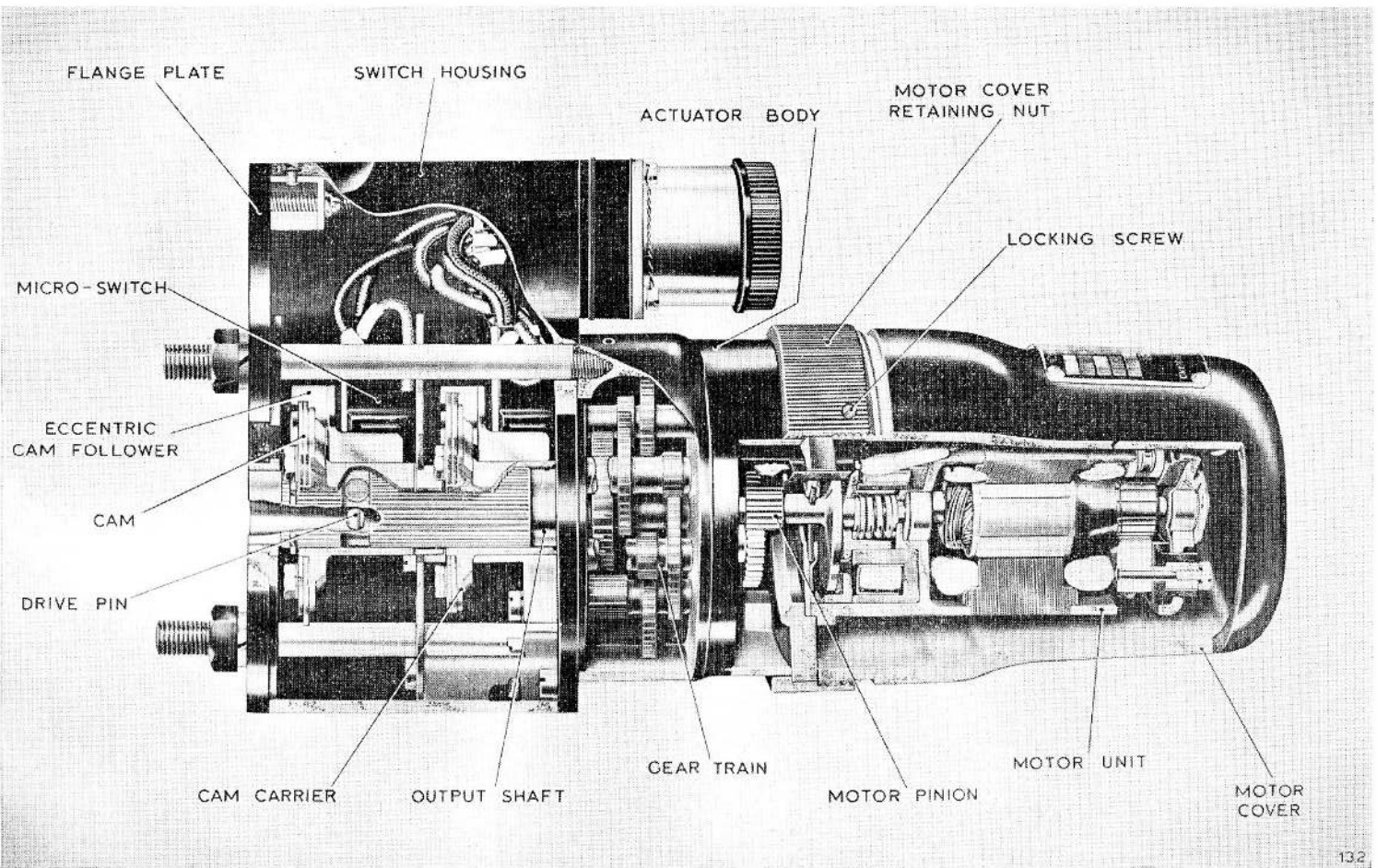

Fig. 1. Cut-away view of actuator  
**RESTRICTED**

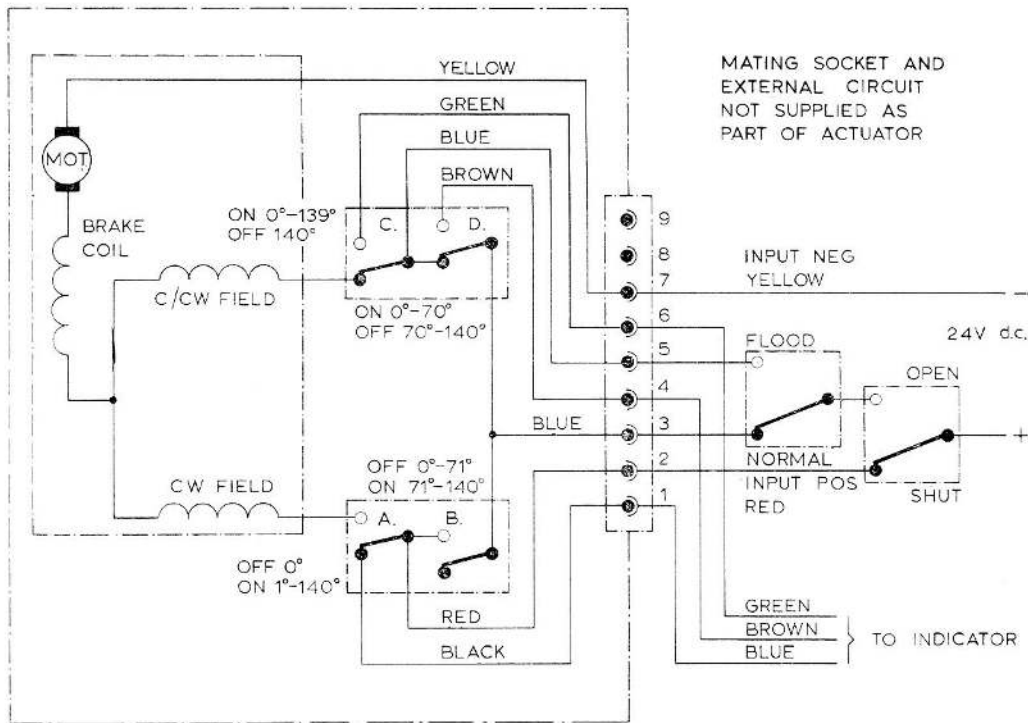

Fig. 2. Circuit diagram

### Actuator body

7. The actuator body contains the gear train, fig. 4, comprising six compound gears, and a final gear formed integrally with the output shaft. The intermediate gear shafts are disposed in a pitch circle about the actuator centre line and locate in ball bearings housed in the actuator body and the switch housing. The inner end of the output shaft is supported in a ball bearing in the actuator body.

### Switch housing

8. The switch housing contains the output shaft, switch operating cam mechanism and four limit switches. The nine-pin electrical plug is also attached to the housing.

### Output shaft

9. The output shaft is serrated externally to register with internally serrated cam carriers, each carrier being separated by a spacer and retained by a circlip; end play

is eliminated by the insertion of shims between each carrier. The stepped drive pin locates in a transverse drilling in the barrel of the output shaft.

### Switch operating mechanism and limit switches

10. The limit switches are actuated by a pair of cams mounted on each cam carrier. The carriers are retained by three screws through slotted holes which provide the means of adjustment.

### OPERATION

11. The four limit switches are arranged in pairs, one pair being secured to the end face of the switch housing and the second pair mounted on a switch platform positioned centrally in the switch housing. The switches are single-pole change-over micro-switches. A switch trigger, hinged to the body of each limit switch, has fixed at its free end an eccentrically mounted cam fol-

**RESTRICTED**

lower, the roller of which bears against the circumferential edge of the cam. As the cam revolves, the lobe causes the switch trigger to actuate the switch button and so make or break the electrical supply.

12. The motor transmits torque via the motor pinion and the reduction gear train

to the output shaft, and thence by the drive pin to the load. The angular travel of the drive pin is controlled by limit switches, the on and off positions of which are controlled by the cams. With 25V d.c. applied to the plug pins as detailed in tables 1, 2 and 3, the supply is fed to the motor via the appropriate limit switch, thus causing the output shaft to rotate in the selected direction.

**TABLE 1**  
**Travel CZ64581**

Plug Pins Energized	Travel
3 and 7	From Shut (0 deg.) to Mid-Position (70 deg.)
also 3 and 7	From Open (140 deg.) to Mid-Position (70 deg.)
5 and 7	From Mid-Position (70 deg.) to Open (140 deg.)
also 5 and 7	From Shut (0 deg.) to Open (140 deg.)
2 and 7	From Mid-Position (70 deg.) to Shut (0 deg.)
also 2 and 7	From Open (140 deg.) to Shut (0 deg.)

**TABLE 2**  
**Travel CZ64581/A**

Plug Pins Energized	Travel
3 and 7	From (0 deg.) to Mid-Position (83 deg.)
also 3 and 7	From Open (166 deg.) to Mid-Position (83 deg.)
5 and 7	From Mid-Position (83 deg.) to Open (166 deg.)
also 5 and 7	From Shut (0 deg.) to Open (166 deg.)
2 and 7	From Mid-Position (83 deg.) to Shut (0 deg.)
also 2 and 7	From Open (166 deg.) to Shut (0 deg.)

**TABLE 3**  
**Indicator and warning lights**

Plug Pins Energized	Indicator and Warning Light
No. 1	Shut position
No. 4	Mid-position
No. 6	Open position

**RESTRICTED**

## SERVICING

### General

13. During routine inspection, the actuator should be examined for external damage. All external nuts, bolts and screws should be checked for security. Check the security of the plug and socket connection. Operate the actuator over its full travel in both directions to ensure that it functions satisfactorily.

### Fault diagnosis

14. If an actuator:

- (1) Will not run —  
Check external circuit and volt-

age supply; check bearing and motor (A.P.4343D, Vol. 1, Book 4, Sect. 20).

- (2) Runs unsatisfactorily —  
Check assembly of moving parts or overheats —  
Check shaft/bearing alignment.
- (3) Overruns —  
Check brake lining for cleanliness (see (1) above).

### Special tools and test equipment

15. The following special tools and test equipment are required for dismantling and testing the actuator.

**TABLE 4**  
**Tools**

Nomenclature	Part No.	Purpose
Ball bearing assembly and peening tool	T.316249	Fitting new ball bearings
Peening fixture for ball bearings	T.314748	Fitting new ball bearings
Stud extractor	T.315022	Remove and fit mounting studs
Ball bearing extractor	T.335202	Remove ball bearings
Crimping pliers	T.353214	Crimping cable thimbles
Special screwdriver	T.314715	For use on round nuts
Flange jig plate	S.K.3772	Maintain position of output shaft
Setting gauge	C.115326	Checking or setting up indicator datum

### Dismantling

16. Dismantle the actuator as follows:—

- (1) Remove the retaining screw, unscrew the cover retaining nut and remove the motor cover.
- (2) Identify and unsolder the motor leads from the terminal block.
- (3) Remove the motor securing nuts and withdraw the motor; retain the greaseguard assembly.
- (4) Remove the motor spigot plate retaining screws and withdraw the plate from the studs.
- (5) Remove the terminal block securing screws and unsolder the connections.
- (6) Remove the grub screws that secure the mounting studs, support the actuator body and switch housing and remove the mounting studs using tool T.315022; slacken the studs equally.
- (7) Separate the actuator body from the switch housing, together with the 1st 'A' gear, lightly tapping the body casting to part the gasket seal. The cable tube should come away from the actuator body as it is removed. Record the number of shims fitted in the out-

**RESTRICTED**

put shaft and retain them for assembling.

(8) Remove the retaining nut from the 1st ('A') gear and withdraw the gear from its shaft. Remove the retaining key and withdraw the shaft through the bearing.

(9) Withdraw the gears from the actuator body.

(10) Remove the flange plate.

(11) Remove the circlip from the output shaft, and slide off the outer cam carrier, shims and spacer. Record the number and size of the shims and retain them for assembling.

(12) Identify and unsolder the outer limit switch leads, remove the switch platform retaining screws and withdraw the switch platform assembly from the housing.

(13) Slide off the inner cam carrier and carefully withdraw the output shaft through the plain bearing of the switch housing.

(14) Remove the two cam plates from each carrier.

(15) Remove the pillar securing screws and remove the pillars from the switch housing.

(16) Identify and unsolder the inner limit switch leads, remove the securing screws from the inner limit switch assemblies and withdraw the assemblies.

(17) Remove the locking wire from the plug securing screws, remove the screws and withdraw the plug and wiring assembly from the housing.

(18) The ball bearings of the actuator body and switch housing are peened in position and can be removed using special tool T.335202.

### Inspection

17. Wash all parts of the actuator, with the exception of the limit switches and plug assembly, in white spirit and remove all traces of grease and dirt. Dry the components using clean, dry, compressed air.

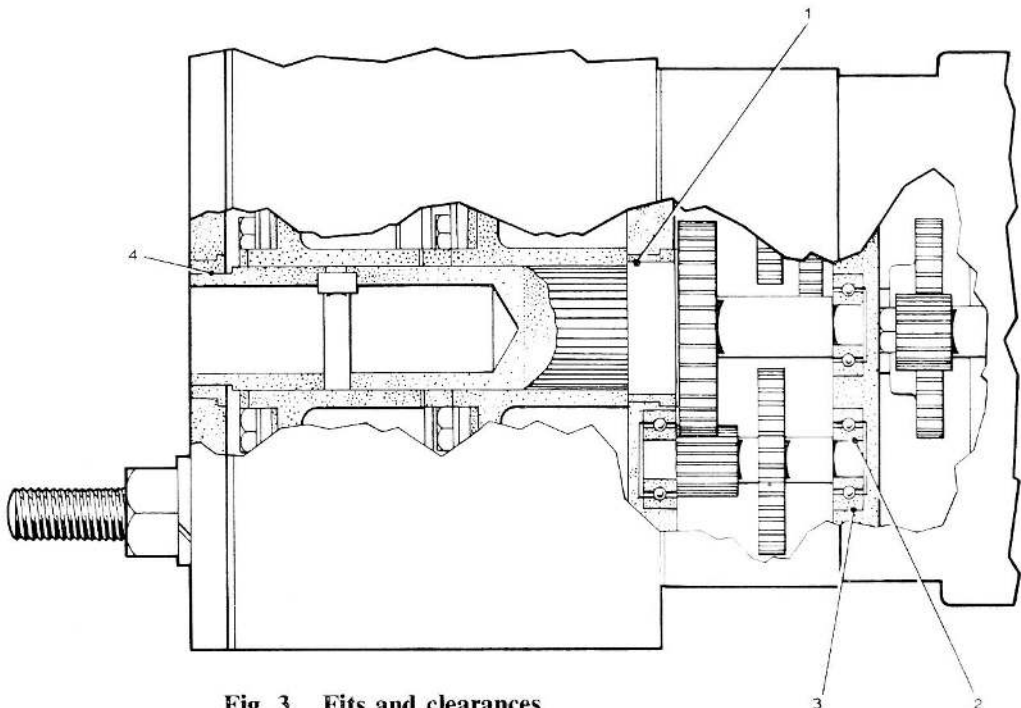

Fig. 3. Fits and clearances

**RESTRICTED**

Lay out the parts and examine them carefully for obvious damage such as distortion, burring and scoring. The parts must then be checked against the Fits, Clearances and Repair Tolerances (Table 6) and all worn parts renewed.

18. (1) The following items must be automatically discarded and new parts used during the assembling procedure.

- (a) Gaskets.
- (b) Tabwashers.

(2) Special attention must be given to the following:—

- (a) Gears: The gear teeth must be examined for burrs.
- (b) Bearings: Check the bearings for free rotation, excessive end float and wear, renew if necessary.
- (c) Limit switches: Check the limit switches for satisfactory snap action and voltage drop across the contacts. A reading of 50 millivolts is acceptable when a current of 2 amps. is passed between the switch terminals. Renew the limit switches if necessary.
- (d) Cables: Inspect the cables for signs of chafing, fraying or overheating. Check each lead for continuity and insulation resistance and renew them as necessary.
- (e) Ensure that all mating surfaces are clean and free of burrs.

## Assembling

### Lubrication

19. (1) Actuators must operate for long periods without internal inspection, thus it is of paramount importance that scrupulous cleanliness be observed when lubricating and re-assembling a unit.
- (2) The actuator should be lubricated progressively during re-assembly.
- (3) Before applying the lubricant the relevant parts must be thoroughly cleaned in an approved solvent and then dried out, using clean dry, compressed air.

### Note . . .

*On no account use cloth in the drying-out process.*

- (4) Parts awaiting lubrication or assembly must at all times be kept in a clean, dry receptacle suitably covered to exclude moisture and dust.
- (5) The correct grease for the actuator XG-275 (Specification D.T.D.825), Ref. No. 34B/9100512.
- (6) The grease must be applied using a suitable tool or spatula: brushes must not be used.
- (7) Gear teeth: Work the lubricant into the spaces between the teeth round the circumference of the gear.
- (8) Ball bearings: Press grease into the space between the inner and outer races for a distance of one-third of the circumference, on both sides of the bearing. If one side is inaccessible, cover two-thirds of the accessible side. Rotate the bearing by hand to distribute the grease.
- (9) Bushes, plain bearings and sliding faces: smear with grease. A greased leather swab may be used for lubricating very small bushes.

### Lacquering and Sealing

20. Use Epihard lacquer for internal use and Cellon Epoxy lacquer for external use.

- (1) Use mixture of three parts (by volume) Epihard lacquer 480/1, Ref. No. 33B/1516, and one part (by volume) Epihard accelerator 480/2, Ref. No. 33B/1517, for all applications. Mix sufficient for one day's use only. Apply to internal screw heads, nuts, washers, terminal block and plug mouldings.

### Caution . . .

*Keep lacquer clear of spigot and joint faces, limit switch, connection screws, ball races and all other moving parts.*

- (2) Use mixture of one part (by volume) of Cellon Epoxy Stoving Enamel SL-5459/Clear to one part (by volume) of Cellon Epoxy Catalyst CSL-

5538. If required 50 per cent (by volume) of Cellon Thinner TSL-5373 may also be added. These are to D.T.D. Spec. 900/4414. The enamel should be applied by brushing and then be air-dried for half-an-hour at a temperature of between 43 deg.C and 49 deg.C (110 deg.F and 120 deg.F).

(3) Use Jointing Compound SQ32/R to D.T.D. 900/4586 according to requirements.

All mating surfaces, after de-greasing using trichlorethylene, should be coated with the jointing compound and allowed to dry for 10 minutes.

Apply the jointing compound under heads of screws, pertinent washers and nuts and to faces of gaskets.

#### General (fig. 7)

**21.** When all components have been prepared, and the motor serviced, assemble the actuators as follows:—

##### 1st Stage

(1) Fit the bearings using tool T.316249. If necessary, the castings may be heated to 90 deg.C (194 deg.F).

(2) Fit the plug and cable assembly to the switch housing using a new gasket and secure with the screws and washers.

(3) Fit the inner limit switches to the face of the switch housing, and, referring to fig. 5, solder the appropriate leads. The leads must be looped around the switch terminals before soldering.

(4) Fit the platform pillars to the inner face of the switch housing.

##### Note . . .

*The leads to the limit switch furthest from the plug are positioned by slots in the pillars.*

(5) Assemble the output shaft, 6th, 4th, 5th, 3rd and 2nd gears, in that order, to the switch housing referring to fig. 4 during assembly.

(6) Assemble the 1st gear to the actuator body. Fit the key and 1st 'A' gear, securing it with a spring washer and nut.

(7) Thread the appropriate plug leads through the slot in the switch housing and cable tube in actuator body, at the same time locating the actuator body to the switch housing. Fit the flange jig plate SK 3773 and clamp to the switch housing and actuator body with the two mounting studs.

(8) Solder the plug leads to the terminal block and secure the block to the actuator body.

(9) Assemble the cover retaining nut and motor spigot plate to the actuator body and secure the spigot plate with its retaining screws.

(10) Fit the grease guard assembly to the motor ensuring that the rubber disc in the guard does not foul the motor shaft.

(11) Fit the motor and secure it with spring washers and nuts. Solder the motor leads to the terminal block.

(12) Locate the motor cover, fit the cover retaining nut and lock it with its retaining screw.

(13) Perform the tests described in paragraphs 22, 23 and 24.

#### Final assembling and travel setting (fig. 6)

**22.** After satisfactory performance of the tests described in paragraphs 23, 24 and 25, proceed as follows:—

(1) Remove the flange jig plate.

(2) Position the actuator so that the drive pin is in the closed position.

(3) Locate the inner cam carrier to the output shaft. Assemble the cams to the cam carrier and adjust them to approximate operating position. The inner cam can be temporarily secured by three screws and the outer cam by the securing screws and tabwashers. Do not lock the screws.

(4) Slacken the nuts that secure the eccentric cam followers using screw-driver T.314715, and adjust the followers by rotating them to provide

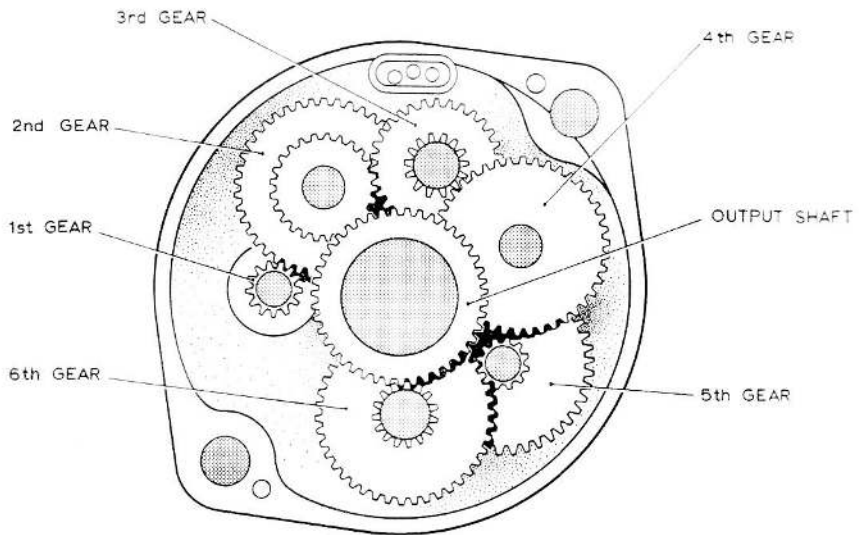
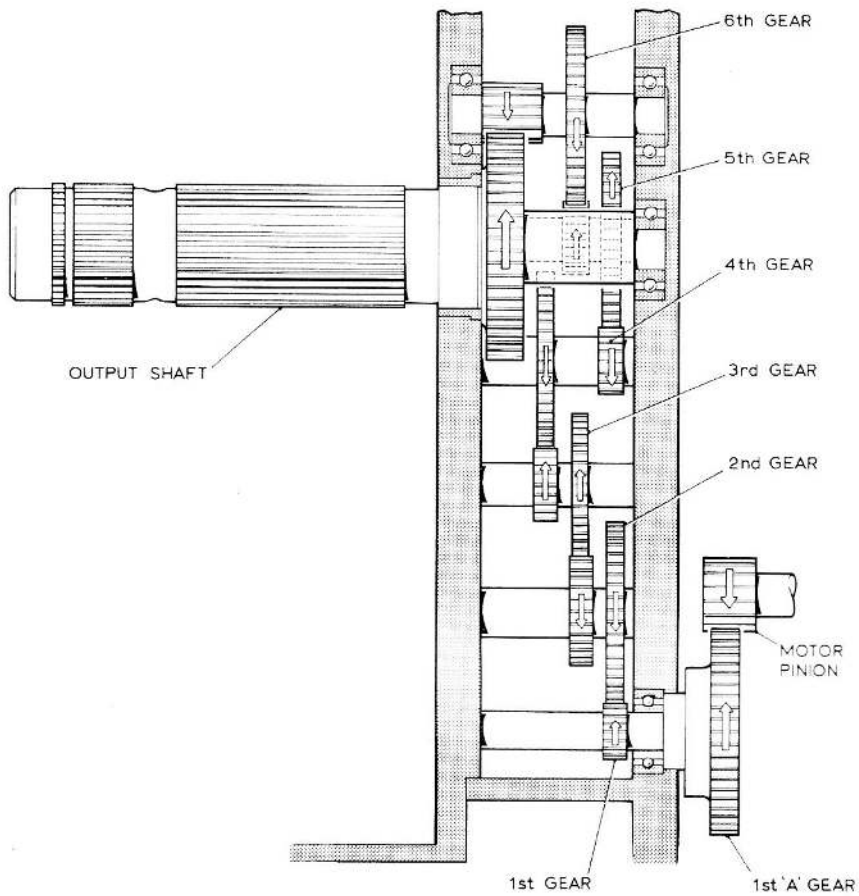

Fig. 4. Gear train

**RESTRICTED**

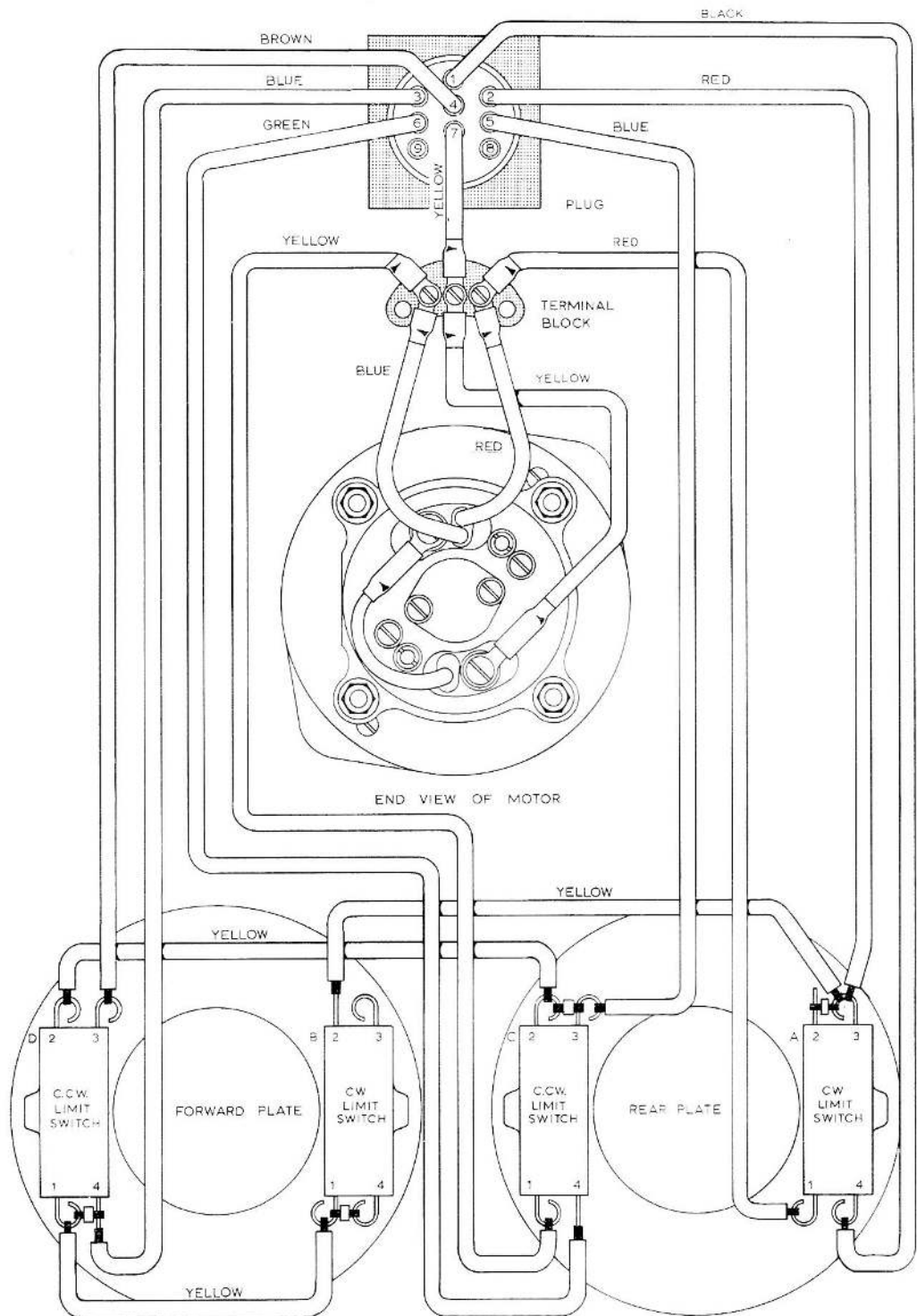
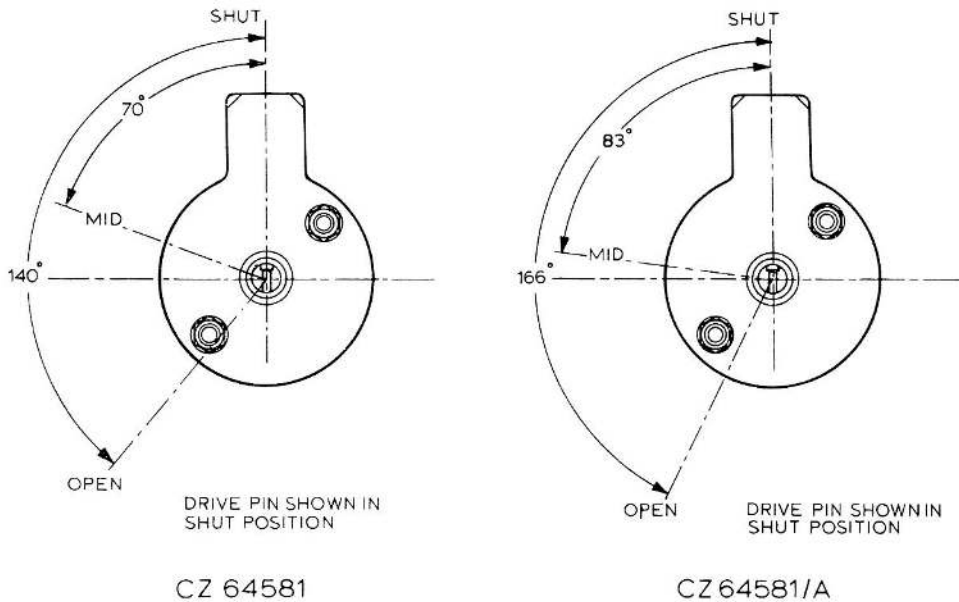

Fig. 5. Wiring diagram

**RESTRICTED**



**Fig. 6. Travel setting diagram**

0.003 in. to 0.008 in. lift after the switch has been operated by the cams.

(5) Fit the flange jig plate SK 3772 and mount the unit on the travel setting rig. Operate the actuator in each direction, and adjust the cams until the required travel is obtained, viz: for actuator CZ64581: 0 deg. to 140 deg. and 140 deg. to 0 deg.; for actuator CZ64581/A: 0 deg. to 166 deg. and 166 deg. to 0 deg., see fig. 6.

In each case the tolerance allowed is plus or minus  $\frac{1}{4}$  deg. from the true position. Allow 70 deg. and 83 deg. unin-

**KEY TO FIG. 7**

- 1 FLANGE PLATE
- 2 GASKET
- 3 INTERMEDIATE CAM (UPPER)
- 4 INTERMEDIATE CAM
- 5 CAM FOLLOWER
- 6 SHIM
- 7 SPACER
- 8 CAM ASSEMBLY (INNER)
- 9 CAM FOLLOWER
- 10 LIMIT SWITCH ASSEMBLY
- 11 SWITCH HOUSING

- 12 OUTPUT SHAFT
- 13 4th GEAR
- 14 5th GEAR
- 15 6th GEAR
- 16 SHIM
- 17 2nd GEAR
- 18 3rd GEAR
- 19 DRIVE PIN
- 20 PLUG, CABLE ASSEMBLY
- 21 PLUG GASKET
- 22 CAM FOLLOWER
- 23 MOUNTING PILLAR
- 24 ROUND NUT, 6 B.A.
- 25 SWITCH PLATFORM
- 26 CAM FOLLOWER
- 27 CAM CARRIER (OUTER)
- 28 CIRCLIP
- 29 MOUNTING STUD
- 30 GASKET
- 31 ACTUATOR BODY
- 32 DOWEL
- 33 SOCKET Hd. SCREW
- 34 LOCKING SCREW
- 35 TERMINAL BLOCK
- 36 MOTOR SPIGOT PLATE
- 37 MOTOR COVER
- 38 MOTOR ASSEMBLY
- 39 GREASE GUARD ASSEMBLY
- 40 KEY, 1st GEAR
- 41 1st GEAR "A"
- 42 COVER RETAINING NUT
- 43 MOTOR CABLE TUBE
- 44 1st GEAR

**RESTRICTED**

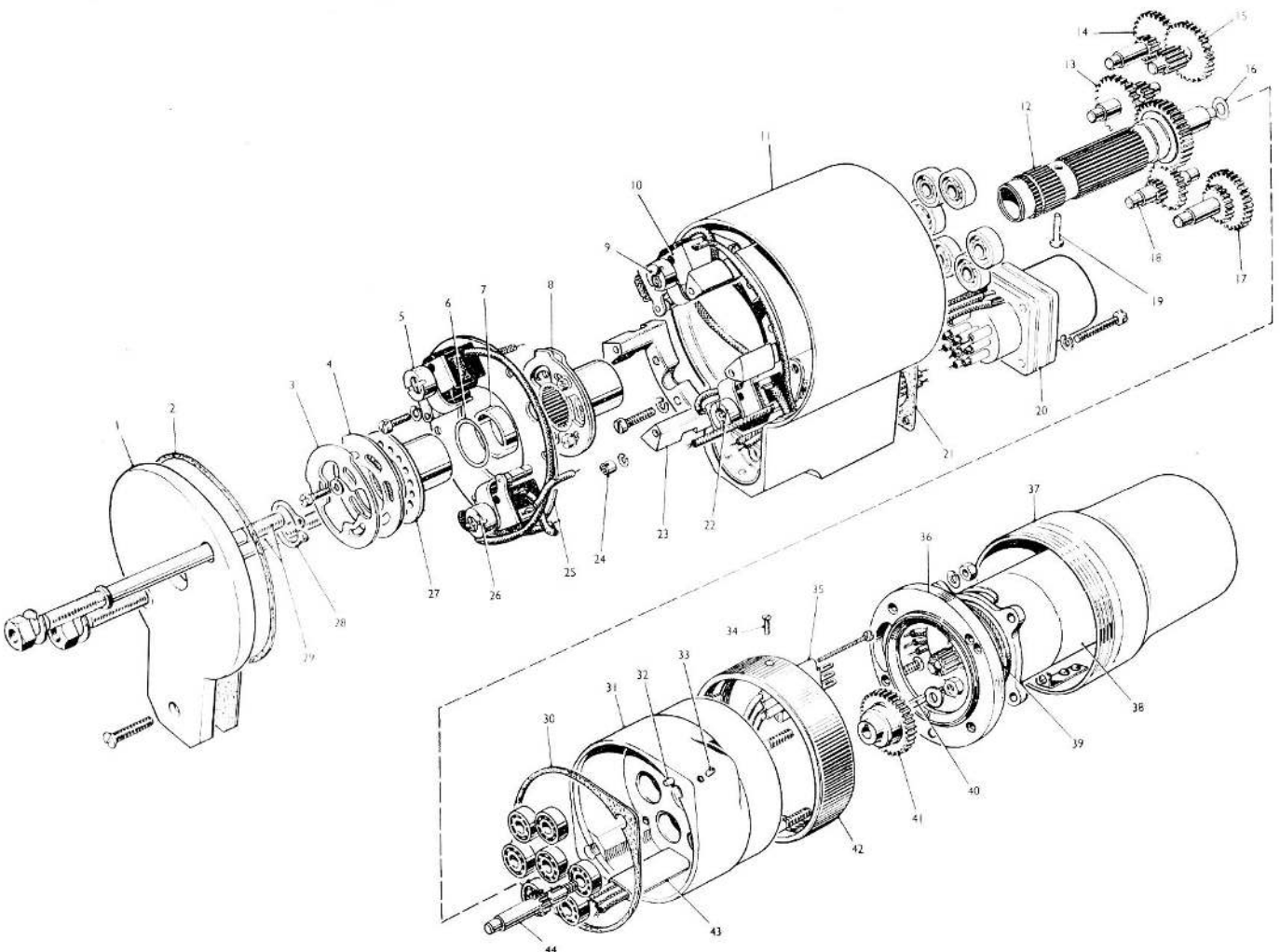

Fig. 7. Exploded view

**RESTRICTED**

errupted travel—respectively to each position, to produce the normal working overrun. Tighten the three hexagon headed screws and lock them with the tab washers. Remove the three screws used to secure the inner cam plate. Remove the flange jig plate.

(6) Fit the limit switch platform assembly into the switch housing, secure it with the spring washers and screws, and solder the leads to the switches. Loop the leads through the switch terminals before soldering.

(7) Assemble the spacer, shims and outer cam carrier to the output shaft and retain them with a new circlip. Assemble the cams to the cam carriers and adjust as in para. 19 (2) .

(8) Adjust the eccentric cam followers as described in para. 19 (3).

(9) Fit the flange jig plate and perform the travel setting procedure as described in sub-para. (5) above, with the exception that the travel now to be obtained for actuator CZ64581 is 0 deg. to 70 deg. and 140 deg. to 70 deg., and for actuator CZ64581/A 0 deg. to 83 deg. and 166 deg. to 83 deg. See fig. 7. Remove the flange jig plate.

(10) Position a new flange plate gasket, lubricate the output shaft bearing bush, fit the flange plate and secure it with the studs and retaining screw. Fit the grub screws to the studs to secure them.

(11) Lock all drilled screw heads with 22 S.W.G. stainless steel wire.

### Testing

23. After assembling the actuator, subject it to the acceptance tests detailed in the following paragraphs. During these tests, ensure that the unit does not become overheated. The tests detailed in paras. 23, 24

and 25 must be performed with the actuator assembled minus the switch operating cams and the mid-position limit switches, thus allowing continuous rotation of the output shaft.

### Functional test

24. With 25V d.c. applied to plug pins 5 and 7, and 2 and 7 respectively, verify that the output shaft rotates in the correct direction in accordance with the circuit diagram fig. 2.

### Note . . .

*When the clockwise motor field is energized, the output shaft viewed at the flange plate end, rotates in a counter-clockwise direction.*

### Brake test

25. With 22V d.c. applied, operate the actuator against 50 lb/in. torque and check that the brake operates satisfactorily. Operate the actuator several times in each direction.

### Load test

26. Couple the actuator to the test rig Ref. No. 4G/6591 using the correct adapter. With 25V d.c. applied, operate the actuator for four revolutions of the output shaft with an opposing load of 60 lb/in. The voltage must be measured at the actuator terminals and be kept constant at the specified voltage whilst the actuator is on load. For time and current see below.

### Insulation resistance test

27. With the actuator completely assembled and the drive pin at the mid-travel position, measure the insulation resistance between each plug pin and the actuator body. Using a 250V insulation resistance tester Type C, Ref. No. 5G/152, the values obtained must not be less than 0.5 megohm.

**TABLE 5**  
**Load test figures**

Applied Voltage	Load lb/in.	Time taken to complete 4 Revolution of the output shaft		Maximum Current (amps.)
		Min.	Max.	
25	60	20 sec.	30 sec.	2.0

**RESTRICTED**

**TABLE 6**  
**Fits and clearances**

Item No.	Description	Dimension New (Inches)	Permissible Worn Dimension (Inches)	Clearance New (Inches)	Permissible Worn Clearance (Inches)	Remarks
1	OUTPUT SHAFT JOURNAL IN BUSH					
	Shaft journal	$\frac{0.6246}{0.6241}$	0.6241	$\frac{0.0002}{0.0014}$ clear	0.0014 clear	
Bush bore	$\frac{0.6255}{0.6248}$	0.6255				
2	GEAR JOURNALS IN BALL BEARINGS					
	Gear journal	$\frac{0.1868}{0.1865}$	0.1865	$\frac{0.0012}{0.0005}$ clear	0.0012 clear	
Ball bearing bore	$\frac{0.1877}{0.1873}$	0.1877				
3	BALL BEARINGS IN ACTUATOR BODY AND SWITCH HOUSING					
	Ball bearing o/dia.	$\frac{0.4997}{0.4993}$	0.4993	$\frac{0.0007 \text{ cl.}}{0.0002 \text{ int.}}$	0.0007 clear	
Actuator body and switch housing bore	$\frac{0.5000}{0.4995}$	0.5000				
4	OUTPUT SHAFT JOURNAL IN FLANGE PLATE BUSH					
	Shaft journal	$\frac{0.5620}{0.5610}$	0.5610	$\frac{0.0050}{0.0030}$ clear	0.0050 clear	
Bush bore	$\frac{0.5660}{0.5650}$	0.5660				

**RESTRICTED**

**Appendix A****STANDARD SERVICEABILITY TESTS  
ACTUATOR, PLESSEY, THREE-POSITION  
PANTHER, TYPES CZ64581 and CZ64581A****LIST OF TABLES**

	<i>Table</i>
<i>Load test figures</i> ... ..	1

**Introduction**

1. The tests detailed in this appendix are intended to check the serviceability of the actuators after servicing before installation.

**Test equipment**

2. The following equipment is required:—

- (1) Tester, insulation resistance, 250V Type C (Ref. No. 5G/152).
- (2) Test rig, rotary actuator (Ref. No. 4G/6591).
- (3) A direct current supply, variable between 18 and 29 volts.

**Insulation resistance test**

3. Using the tester referred to in (1) above, with the actuator completely assembled and the drive pin at the mid-travel position, measure the insulation resistance between each plug pin and the actuator body. The values obtained must not be less than 0.5 megohm.

**Functional test**

4. With 25V d.c. applied to plug pins 5 and 7 and to 2 and 7 respectively, verify that the output shaft rotates in the correct direction.

**TABLE 1****Load test figures**

Applied Voltage	Load lb/in.	Time taken to complete 4 Revolutions of the output shaft		Maximum Current (amps.)
		Min.	Max.	
25	60	20 sec.	30 sec.	2.0

**RESTRICTED**



This file was downloaded from the RTFM Library.  
Link: [www.scottbouch.com/rtfm](http://www.scottbouch.com/rtfm)

Please see site for usage terms, and more aircraft documents.

