

## Chapter 3

### ACTUATORS, ROTAX, C5200 SERIES

#### LIST OF CONTENTS

	<i>Para.</i>		<i>Para.</i>
<i>Introduction</i> ... ..	1	<b>Servicing</b> ... ..	10
<b>Description</b> ... ..	2	<i>Brushgear</i> ... ..	11
<i>Motor, clutch and brake</i> ... ..	3	<i>Lubrication</i> ... ..	12
<i>Gear train and release mechanism</i> ... ..	6	<i>Gear release mechanism</i> ... ..	13
<i>Operation</i> ... ..	7	<i>Testing</i> ... ..	14
<b>Installation</b> ... ..	9		

#### LIST OF ILLUSTRATIONS

	<i>Fig.</i>		<i>Fig.</i>
<i>General view of typical actuator</i> ... ..	1	<i>Typical cabin hood control circuit</i> ... ..	3
<i>Sectional view of actuator</i> ... ..	2	◀ <i>Diagram of internal connections</i> ... ..	4 ▶

#### LIST OF APPENDICES

	<i>App.</i>		<i>App.</i>
◀ <i>Standard serviceability test for actuators, Rotax, C5200 series</i> ... ..	A ▶	<i>Actuator, Rotax Type C5209</i> ... ..	4
<i>Actuator, Rotax, Type C5201/1</i> ... ..	1	<i>Actuator, Rotax, Type C5210/1</i> ... ..	5
<i>Actuator, Rotax, Type C5206/1</i> ... ..	2	<i>Actuator, Rotax, Type C5212</i> ... ..	6
<i>Actuator, Rotax, Type C5208</i> ... ..	3	<i>Actuator, Rotax, Type C5215</i> ... ..	7
		<i>Actuator, Rotax, Type C5216</i> ... ..	8

**RESTRICTED**

## Introduction

1. The actuators of the C5200 series have been designed to open and close the cabin hood in aircraft having a 28-volt d.c. supply, but it is possible that they may be used for other purposes. They are suitable for operation up to altitudes of 60,000 ft., at ambient temperatures between  $-40$  deg. C and  $+50$  deg. C.

## DESCRIPTION

2. A typical actuator in the series, the Type C5201/1, is illustrated in fig. 1 and 2. The actuator normally incorporates a small reversible shunt-wound motor, which drives the splined drive shaft through a three-stage epicyclic gear train.

### Motor, clutch and brake

3. The electric motor is of 4-pole construction, rated at 28 volts d.c. It transmits its drive through a single-plate spring-loaded clutch, which bears on the inner face of the rotating brake drum, integral with which is the first sun gear of the gear train. The clutch is so set that it will slip under excessive load, thus preventing damage to the mechanism.

4. The brush gear assembly incorporates four brushes connected as shown in the typical circuit diagram in fig. 3 and diagram of internal connections in fig. 4. Access to the brushes is gained by removing the brush inspection cover, and the connections from the aircraft electrical supply are made to either a terminal block or a plug situated on the motor cover.

5. Between the motor and clutch is an electro-magnetic brake mechanism. This consists of an 8-pole brake spider, with eight pole shoes which bear radially under spring pressure against the inner periphery of the brake drum. The brake coil is connected in series with the armature of the motor so that when the motor is switched on, the brake coil is energized. This attracts the brake shoes to the poles of the spider, and releases the brake, so that the rotation of the armature shaft is transmitted via the clutch to the brake drum and gear train.

### Gear train and release mechanism

6. The drive is taken from the armature shaft to the splined drive shaft by a three-stage epicyclic gear train, which produces the necessary reduction in speed from the motor

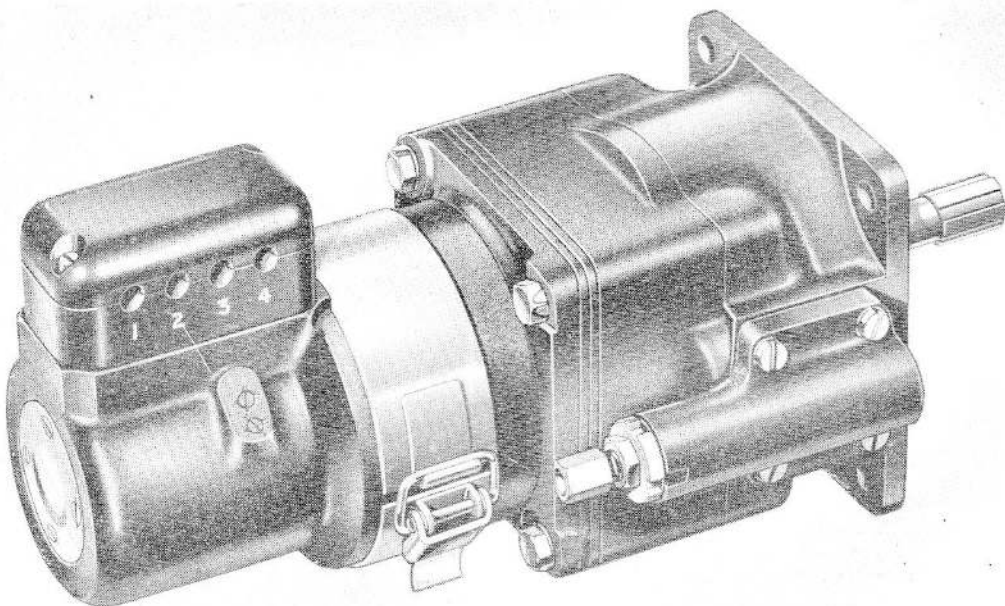

Fig. 1. General view of typical actuator

RESTRICTED

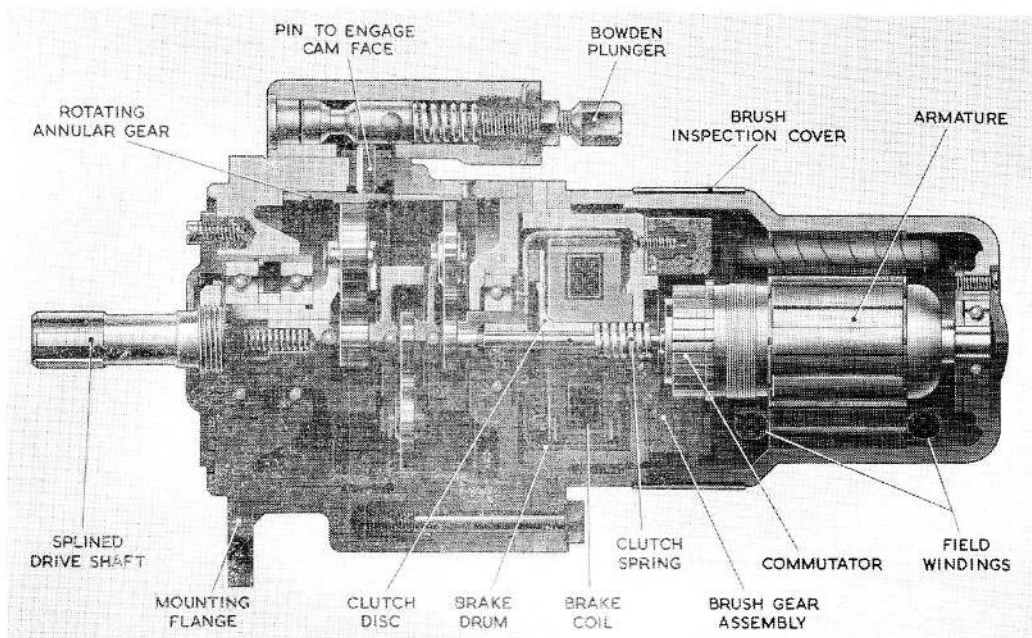

Fig. 2. Sectional view of actuator

to the drive shaft. When the release mechanism is operated by pulling on the Bowden plunger, the final annular gear is free to rotate, allowing the equipment which the actuator is operating to become free. When the plunger is allowed to run back into position, a cone-shaped pin is brought into engagement with a cam face on the rotating annular gear, thus keeping it rigid for transmitting drive to the splined shaft.

### Operation

7. The actuator is normally controlled by a relay in the F1300 series, information on which will be found in A.P.4343C, Vol. 1, Book 2. This relay incorporates two operating coils, one for clockwise rotation and the other for anti-clockwise rotation of the actuator, which are energized by operation of the appropriate external push-switch. The relay shown in fig. 3 is the Type F1301, which incorporates a time delay to allow deflation of the hood seal to take place before the cabin hood is opened. This time delay is adjustable to cater for cable voltage drop. A similar relay, the Type F1302, may

be used as an alternative to the Type F1301; this does not, however, incorporate a time delay, and is intended for use with non-pressurized cabins.

8. When the appropriate control push-switch is depressed, the motor in the actuator is energized and rotates in the required direction. The brake coil is also energized, thus releasing the brake and allowing the drive to be transmitted through the gear train to the drive shaft. When the motor is de-energized at the end of its travel by the appropriate external limit switch, the brake coil is de-energized simultaneously, thus stopping instantly the actuation of the mechanism.

### INSTALLATION

9. The actuator may be mounted in any attitude, using the four holes of 0.281 in. diameter equispaced on a P.C.D. of 3.812 in. provided on the flange which has a spigot of 2.75 in. diameter. The output shaft has six splines on an 0.5 in. diameter.

RESTRICTED

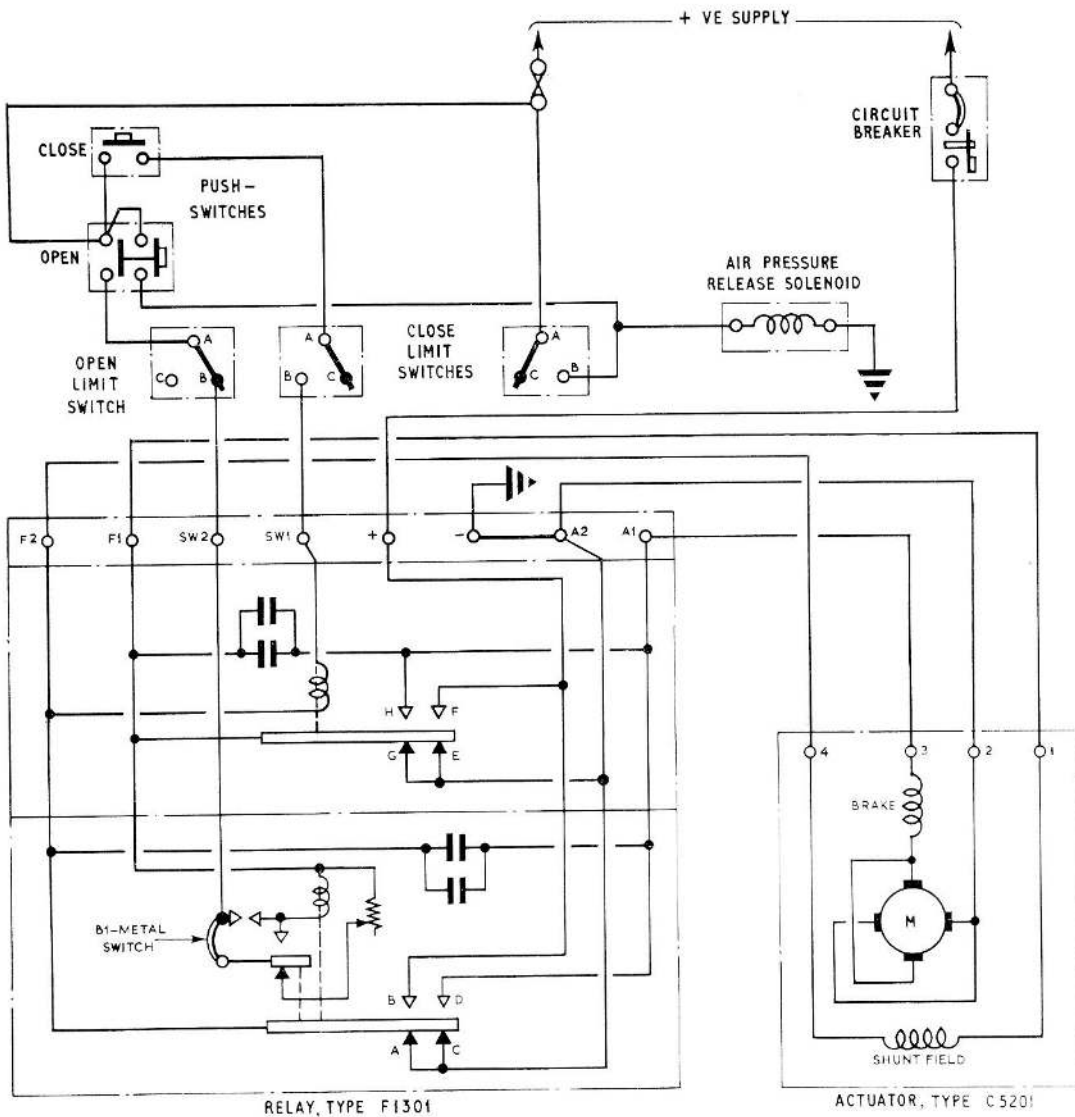

Fig. 3. Typical cabin hood control circuit

### SERVICING

10. These actuators should be serviced in accordance with the general chapter in A.P.4343, Vol. 1, Sect. 17, Chap. 1, and the instructions contained in the relevant Servicing Schedule. ◀ Full repair information will be found in A.P.4343D, Vol. 6, Book 5, Sect. 16, Chap. 3. ▶

#### Brushgear

11. Service the brushgear in the following manner:—

- (1) Remove the brush inspection cover.
- (2) The minimum length beyond which brushes should not be used is 0.325 in., the new length being 0.4 in. Brushes should be renewed at periods prescribed in the relevant Servicing Schedule, and whenever examination reveals that they will not remain serviceable for the period that must elapse before the next servicing.
- (3) Check the brush spring pressure;

**RESTRICTED**

this should be between 5 and 7 oz. (141 and 199 gm.).

- (4) Refit the brush inspection cover.

### Lubrication

12. The ball bearings of the actuator are lubricated with grease XG-275 during manufacture and repair, and should not normally require lubricating during servicing periods.

### Gear release mechanism

13. If the cover of the gear release mechanism is removed, care should be taken not to lose the release pin. When re-fitting the cover, ensure that the cone-shaped end of the release pin engages with the cam face of the rotating annulus.

### Testing

14. If the serviceability of the actuator is suspect, it may be tested as laid down in Appendix A. ▶

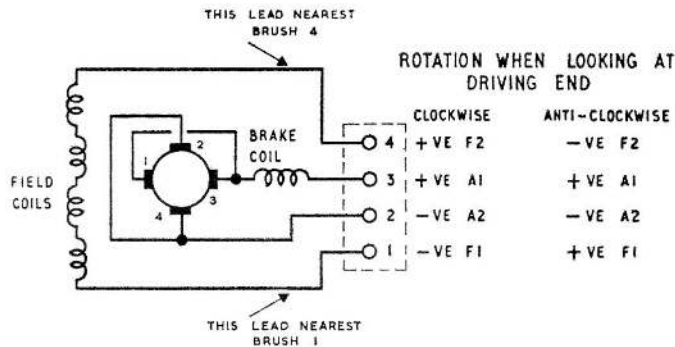

Fig. 4. Diagram of internal connections

## Appendix A

### STANDARD SERVICEABILITY TEST FOR ACTUATORS, ROTAX, C5200 SERIES

#### Introduction

1. The following tests may be applied to the actuator before it is put into service, or at any time when its serviceability is suspect.

#### Test equipment

2. The following test equipment is required:—

- (1) Tension gauge (Ref. No. 1H/59).
- (2) Rotary actuator test rig (Ref. No. 4G/6591).
- (3) Insulation resistance tester, Type C (Ref. No. 5G/152).

#### Testing

##### Brushgear

3. Check the brush length and brush spring pressure the brush length should not be less than 0.4 in. and the spring pressure should lie between 5 and 7 oz. (141 and 199 gm.).

##### Performance

4. Set the actuator on the test rig, using the appropriate fittings as indicated in Table 1, and ensure that it operates within the limits given in Table 2. The tests should be made for each direction of rotation, and at 24V and 29V.

**TABLE 1**  
**Actuator fittings**

Type	Adapter	Drive coupling
C5201,1	7	17
C5206/1	7	17
C5208	7	17
C5209	7	17
C5210/1	7	17
C5212		
C5215	7	17
C5216	7	17

**TABLE 2**  
**Test data**

Voltage (d.c.)	Current (amp.)	Speed of output shaft (r.p.m.)	Torque (lb. ft.)
24	3.5 — 5.75	48—61	0
24	14.5 — 18.0	42—51	25.5
29	3.75— 6.0	50—69	0
29	14.0 — 16.5	48—58	25.5

5. The actuator must operate on 18 volts against a normal load.

##### Insulation resistance

6. The insulation resistance, measured with a 250-volt insulation resistance tester between all live parts and the frame, should be not less than 50,000 ohms.

**RESTRICTED**

## Appendix 1

### ACTUATORS, ROTAX, TYPE C5201/1

#### LEADING PARTICULARS

Actuator, Type C5201/1 ... ..	Ref. No. 5W/7
Nominal voltage ... ..	28V d.c.
Current (at normal operating torque) ... ..	16.5 amp.
Normal operating torque (at 52 r.p.m.) ... ..	25 lb. ft.
No load speed ... ..	58 r.p.m.
Maximum static torque ... ..	90 lb. ft.
Clutch setting ... ..	30—45 lb. ft.
Time rating ... ..	1 min.
Angle of rotation ... ..	Continuous rotation in either direction
Brush spring pressure ... ..	5—7 oz. (141—199 gm.)
Minimum brush length ... ..	0.325 in.
Brush length (new) ... ..	0.4 in.
Reduction gear ratio ... ..	275:1
Release mechanism ... ..	Pull 20 lb. at 25 lb. ft. output torque. Travel 0.218 in.
Overall dimensions—	
Length ... ..	8.75 in.
Width (over terminal block) ... ..	4 in.
Height (over release mechanism) ... ..	3.9 in.
Weight ... ..	4 lb. 14 oz.

1. This actuator is identical in construction to that described and illustrated in the main chapter. Electrical connection is made to a 4-way S.B.A.C. type terminal block.

**RESTRICTED**

## Appendix 2

### ACTUATOR, ROTAX, TYPE C5206/1

#### LEADING PARTICULARS

Actuator, Type C5206/1	...	...	...	...	...	...	Ref. No. 5W/378
Nominal voltage	...	...	...	...	...	...	28V d.c.
Current (at normal operating torque)	...	...	...	...	...	...	16.5 amp.
Normal operating torque (at 52 r.p.m.)	...	...	...	...	...	...	25 lb. ft.
No load speed	...	...	...	...	...	...	58 r.p.m.
Maximum static torque	...	...	...	...	...	...	125 lb. ft.
Clutch setting	...	...	...	...	...	...	30—45 lb. ft.
Time rating	...	...	...	...	...	...	1 min.
Angle of rotation	...	...	...	...	...	...	Continuous rotation in either direction
Brush spring pressure	...	...	...	...	...	...	5—7 oz. (141—199 gm.)
Minimum brush length	...	...	...	...	...	...	0.325 in.
Brush length (new)	...	...	...	...	...	...	0.4 in.
Reduction gear ratio	...	...	...	...	...	...	275:1
Release mechanism	...	...	...	...	...	...	Pull 20 lb. at 25 lb. ft. output torque. Travel 0.218 in.
Overall dimensions—							
Length	...	...	...	...	...	...	8.7 in.
Width (over terminal block)	...	...	...	...	...	...	4 in.
Height (over release mechanism)	...	...	...	...	...	...	3.9 in.
Weight	...	...	...	...	...	...	4 lb. 15 oz.

1. This actuator is generally similar in construction to that described and illustrated in the main chapter. Except for a modified brake coil arrangement to permit of a greater static torque, the actuator is identical to the Type C5201/1, which it supersedes. Electrical connection is made to a 4-way S.B.A.C. type terminal block.

**RESTRICTED**

## Appendix 3

## ACTUATOR, ROTAX, TYPE C5208

## LEADING PARTICULARS

<b>Actuator, Type C5208</b>	...	...	...	...	...	...	...	...	Ref. No. 5W/278
Normal voltage	...	...	...	...	...	...	...	...	28V d.c.
Current (at normal operating torque)	...	...	...	...	...	...	...	...	16.5 amp.
Normal operating torque (at 52 r.p.m.)	...	...	...	...	...	...	...	...	25 lb. ft.
No load speed	...	...	...	...	...	...	...	...	58 r.p.m.
Maximum static torque	...	...	...	...	...	...	...	...	125 lb. ft.
Clutch setting	...	...	...	...	...	...	...	...	30—45 lb. ft.
Time rating	...	...	...	...	...	...	...	...	1 min.
Angle of rotation	...	...	...	...	...	...	...	...	Continuous rotation in either direction
Brush spring pressure	...	...	...	...	...	...	...	...	5—7 oz. (141—199 gm.)
Minimum brush length	...	...	...	...	...	...	...	...	0.325 in.
Brush length (new)	...	...	...	...	...	...	...	...	0.4 in.
Reduction gear ratio	...	...	...	...	...	...	...	...	275:1
Release mechanism	...	...	...	...	...	...	...	...	Pull 20 lb. at 25 lb. ft. output torque. Travel 0.218 in.
Overall dimensions—									
Length	...	...	...	...	...	...	...	...	8.675 in.
Width (over terminal block)	...	...	...	...	...	...	...	...	4.137 in.
Height (over release mechanism)	...	...	...	...	...	...	...	...	4.337 in.
Weight	...	...	...	...	...	...	...	...	4 lb. 15 oz.

1. This actuator is generally similar in construction to that described and illustrated in the main chapter. Except for a modified cover band, it is identical to the Type C5206/1. Electrical connection is made to a 4-way S.B.A.C. type terminal block.

RESTRICTED

## Appendix 4

### ACTUATOR, ROTAX, TYPE C5209

#### LEADING PARTICULARS

Actuator, Type C5209	...	...	...	...	...	...	...	...	...	Ref. No. 5W/309
Normal voltage	...	...	...	...	...	...	...	...	...	28V d.c.
Current (at normal operating torque)	...	...	...	...	...	...	...	...	...	16.5 amp.
Normal operating torque (at 52 r.p.m.)	...	...	...	...	...	...	...	...	...	25 lb. ft.
No load speed	...	...	...	...	...	...	...	...	...	58 r.p.m.
Maximum static torque	...	...	...	...	...	...	...	...	...	125 lb. ft.
Clutch setting	...	...	...	...	...	...	...	...	...	30—45 lb. ft.
Time rating	...	...	...	...	...	...	...	...	...	1 min.
Angle of rotation	...	...	...	...	...	...	...	...	...	Continuous rotation in either direction
Brush spring pressure	...	...	...	...	...	...	...	...	...	5—7 oz. (141—199 gm.)
Minimum brush length	...	...	...	...	...	...	...	...	...	0.325 in.
Brush length (new)	...	...	...	...	...	...	...	...	...	0.4 in.
Reduction gear ratio	...	...	...	...	...	...	...	...	...	275:1
Release mechanism	...	...	...	...	...	...	...	...	...	Pull 20 lb. at 25 lb. ft. output torque. Travel 0.218 in.
Overall dimensions—										
Length	...	...	...	...	...	...	...	...	...	8.675 in.
Width (over plug adapter)	...	...	...	...	...	...	...	...	...	4.75 in.
Height (over release mechanism)	...	...	...	...	...	...	...	...	...	4.362 in.
Weight	...	...	...	...	...	...	...	...	...	4 lb. 15 oz.

1. This actuator is generally similar in construction to that described and illustrated in the main chapter. Electrical connection is,

however, made to a 4-pole plug (Ref. No. 5W/1388) a diagram of internal connections is given in fig. 2.

**Fig. 1. Actuator, Type C5209**

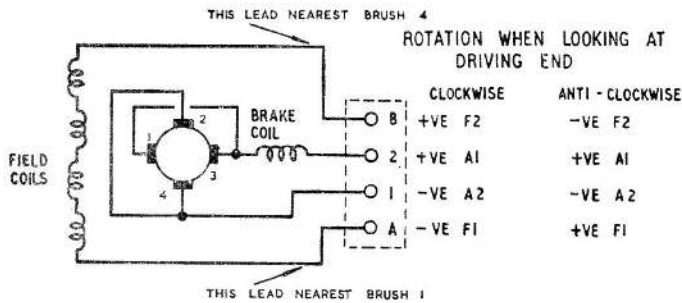
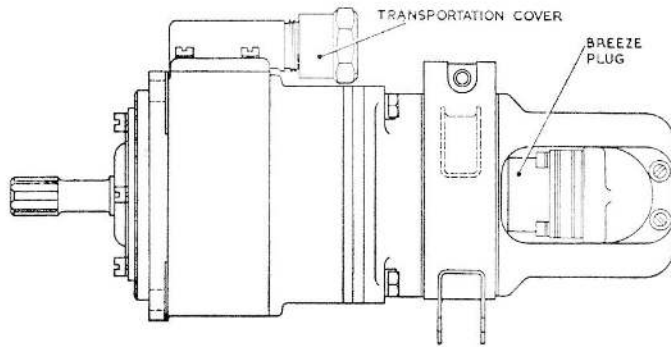

**Fig. 2. Diagram of internal connections**

**RESTRICTED**

## Appendix 5

### ACTUATOR, ROTAX, TYPE C5210/1

#### LEADING PARTICULARS

Actuator, Type C5210/1	...	...	...	...	...	...	Ref. No. 5W/336
Normal voltage	...	...	...	...	...	...	28V d.c.
Current (at normal operating torque)	...	...	...	...	...	...	16.5 amp.
Normal operating torque (at 52 r.p.m.)	...	...	...	...	...	...	25 lb. ft.
No load speed	...	...	...	...	...	...	58 r.p.m.
Maximum static torque	...	...	...	...	...	...	125 lb. ft.
Clutch setting	...	...	...	...	...	...	30—45 lb. ft.
Time rating	...	...	...	...	...	...	1 min.
Angle of rotation	...	...	...	...	...	...	Continuous rotation in either direction
Brush spring pressure	...	...	...	...	...	...	5—7 oz. (141—199 gm.)
Minimum brush length	...	...	...	...	...	...	0.325 in.
Brush length (new)	...	...	...	...	...	...	0.4 in.
Reduction gear ratio	...	...	...	...	...	...	275:1
Release mechanism	...	...	...	...	...	...	Pull 20 lb. at 25 lb. ft. output torque. Travel 0.218 in.
Overall dimensions—							
Length	...	...	...	...	...	...	8.675 in.
Width (over plug)	...	...	...	...	...	...	4.5 in.
Height (over release mechanism)	...	...	...	...	...	...	4.36 in.
Weight	...	...	...	...	...	...	4 lb. 15 oz.

1. This actuator is generally similar in construction to that described and illustrated in the main chapter. Electrical connection is, however, made to a 4-pole plug (Ref. No.

5X/6031); the type and position of this plug is the only point of difference between this and the C5209 actuator details of which are given in Appendix 4.

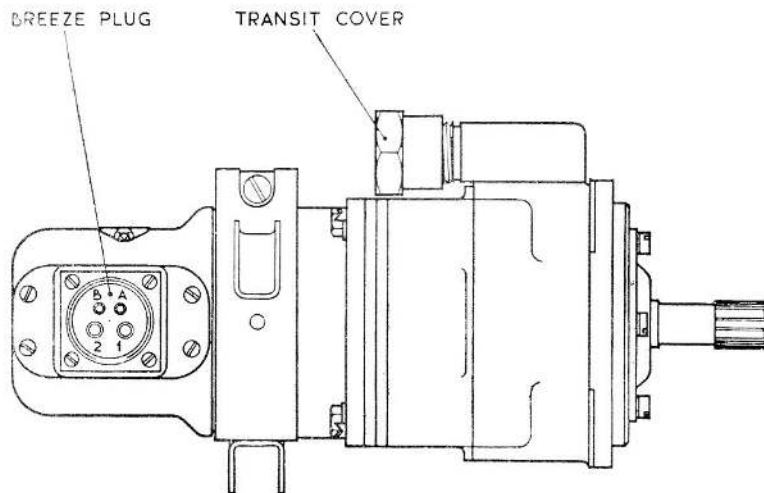

Fig. 1. Actuator, Type C5210/1

RESTRICTED

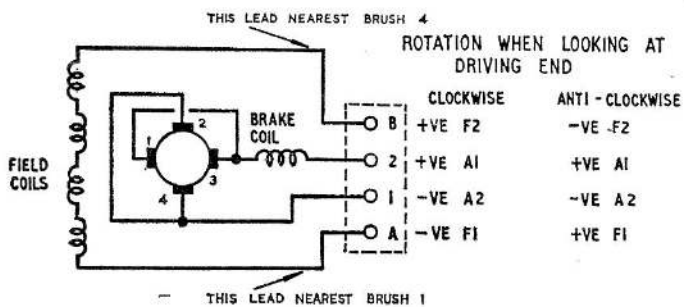

Fig. 2. Diagram of internal connections

**RESTRICTED**

## Appendix 6

### ACTUATOR, ROTAX, TYPE C5212

#### LEADING PARTICULARS

<b>Actuator, Type</b>	<b>C5212</b>	...	...	...	...	...	...	...	...	Ref. No. 5W/430
	<b>C5212/1</b>	...	...	...	...	...	...	...	...	Ref. No. 5W/3907
	<b>C5212/2</b>	...	...	...	...	...	...	...	...	Ref. No. 5W/4208
Normal voltage	...	...	...	...	...	...	...	...	...	28V d.c.
Current (at normal operating torque)	...	...	...	...	...	...	...	...	...	16.5 amp.
Normal operating torque (at 52 r.p.m.)	...	...	...	...	...	...	...	...	...	25 lb. ft.
No load speed	...	...	...	...	...	...	...	...	...	58 r.p.m.
Maximum static torque	...	...	...	...	...	...	...	...	...	125 lb. ft.
Clutch setting	...	...	...	...	...	...	...	...	...	30—45 lb. ft.
Time rating	...	...	...	...	...	...	...	...	...	1 min.
Angle of rotation	...	...	...	...	...	...	...	...	...	Continuous rotation in either direction
Brush spring pressure	...	...	...	...	...	...	...	...	...	5—7 oz. (141—199 gm.)
Minimum brush length	...	...	...	...	...	...	...	...	...	0.325 in.
Brush length (new)	...	...	...	...	...	...	...	...	...	0.4 in.
Reduction gear ratio	...	...	...	...	...	...	...	...	...	275:1
Release mechanism—										
Pull	...	...	...	...	...	...	...	...	...	20 lb at 25 lb. ft. output torque
Travel	...	...	...	...	...	...	...	...	...	0.218 in.
Overall dimensions—										
Length	...	...	...	...	...	...	...	...	...	7.795 in.
Width (over terminal block)	...	...	...	...	...	...	...	...	...	3.937 in.
Height (over release mechanism)	...	...	...	...	...	...	...	...	...	3.9 in.
Weight	...	...	...	...	...	...	...	...	...	4 lb. 15 oz.

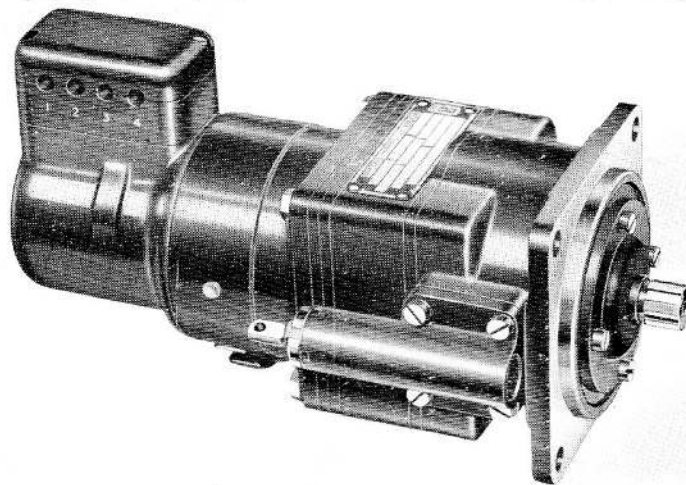

Fig. 1. Type C5212 actuator

RESTRICTED

1. This actuator is generally similar in construction to that described and illustrated in the main chapter. The output shaft, however, is shorter than that of others in the series and extends only 1.1 in. from the face of the mounting flange. Electrical connection is made to a 4-way S.B.A.C. type terminal block.

2. The original Type C5212 was converted to C5212/1 by the introduction of a re-designed release mechanism, to obviate inadvertent seizing of the mechanism. Type C5212/2 has the release shackle turned through 90 deg.

**RESTRICTED**

## Appendix 7

## ACTUATOR, ROTAX, TYPE C5215

## LEADING PARTICULARS

<b>Actuator, Type C5215</b>	...	...	...	...	...	...	...	Ref. No. 5W/
Nominal voltage	...	...	...	...	...	...	...	28V d.c.
Current (at normal operating torque)	...	...	...	...	...	...	...	16.5 amp.
Normal operating torque (at 52 r.p.m.)	...	...	...	...	...	...	...	25 lb. ft.
No load speed	...	...	...	...	...	...	...	58 r.p.m.
Maximum static torque	...	...	...	...	...	...	...	125 lb. ft.
Clutch setting	...	...	...	...	...	...	...	30—45 lb. ft.
Time rating	...	...	...	...	...	...	...	1 min.
Angle of rotation	...	...	...	...	...	...	...	Continuous rotation in either direction
Brush spring pressure	...	...	...	...	...	...	5—7 oz. (141—199 gm.)	
Minimum brush length	...	...	...	...	...	...	...	0.325 in.
Brush length (new)	...	...	...	...	...	...	...	0.4 in.
Reduction gear ratio	...	...	...	...	...	...	...	275:1
Release mechanism	...	...	...	...	...	...	...	Pull 20 lb. at 25 lb. ft. output torque. Travel 0.218 in.
Overall dimensions—								
Length	...	...	...	...	...	...	...	9.175 in.
Width (over terminal block)	...	...	...	...	...	...	...	3.8 in.
Height (over release mechanism)	...	...	...	...	...	...	...	3.91 in.
Weight	...	...	...	...	...	...	...	4 lb. 15 oz.

1. This actuator is generally similar in construction to that described and illustrated in the main chapter. It differs from the Type C5206/1 only in the terminal block, which has terminals suitable for AMP type lugs.

RESTRICTED

## Appendix 8

### ACTUATOR, ROTAX, TYPE C5216

#### LEADING PARTICULARS

<b>Actuator, Type C5216</b>	...	...	...	...	...	...	...	...	Ref. No. 5W/4122
Nominal voltage	...	...	...	...	...	...	...	...	28V d.c.
Current (at normal operating torque)	...	...	...	...	...	...	...	...	16.5 amp.
Normal operating torque (at 52 r.p.m.)	...	...	...	...	...	...	...	...	25 lb. ft.
No load speed	...	...	...	...	...	...	...	...	58 r.p.m.
Maximum static loading	...	...	...	...	...	...	...	...	125 lb. ft.
Clutch setting	...	...	...	...	...	...	...	...	30—45 lb. ft.
Time rating	...	...	...	...	...	...	...	...	1 min.
Angle of rotation	...	...	...	...	...	...	...	...	Continuous rotation in either direction
Brush spring pressure	...	...	...	...	...	...	...	...	5—7 oz. (141—199 gm.)
Minimum brush length	...	...	...	...	...	...	...	...	0.325 in.
Brush length (new)	...	...	...	...	...	...	...	...	0.400 in.
Brush grade	...	...	...	...	...	...	...	...	Carbon (EGO/9C)
Minimum commutator diameter	...	...	...	...	...	...	...	...	0.965 in.
Commutator diameter (new)	...	...	...	...	...	...	...	...	0.990 in.
Reduction gear ratio	...	...	...	...	...	...	...	...	275:1
Release mechanism	...	...	...	...	...	...	...	...	Pull 20 lb. at 25 lb. ft. output torque. Travel 0.218 in.
Ambient temperature range	...	...	...	...	...	...	...	...	—40 deg. C. to +50 deg. C.
Maximum altitude	...	...	...	...	...	...	...	...	60,000 ft.
Overall dimensions—									
Length	...	...	...	...	...	...	...	...	9.175 in.
Width (over terminal block)	...	...	...	...	...	...	...	...	3.800 in.
Height (over release mechanism)	...	...	...	...	...	...	...	...	3.910 in.
Weight	...	...	...	...	...	...	...	...	4 lb. 15 oz.

RESTRICTED

1. The C5216 actuator is similar in construction to that described and illustrated in the main chapter. It differs from the C5215 in that the release mechanism only has been modified to suit a particular application for a new flexible type of cable installation.

2. The difference in the release mechanism

is the method of securing the cable to a new emergency slider contained within the housing; this is effected by fitting a locking pin to secure the cable end in the slider. The gland nut continues to retain the slider and cable assembly within the housing but the internal diameter has been increased to permit freedom of movement for the flexible cable.

**RESTRICTED**

This file was downloaded  
from the RTFM Library.

Link: [www.scottbouch.com/rtfm](http://www.scottbouch.com/rtfm)

Please see site for usage terms,  
and more aircraft documents.

