

Chapter 30

ACTUATOR, WESTERN, TYPE ERJ60, Mk. 31F

LIST OF CONTENTS

| | <i>Para.</i> | | <i>Para.</i> |
|--------------------------------------|--------------|-----------------------------------------|--------------|
| <i>Introduction</i> | 1 | <i>Electrical connection</i> | 9 |
| Description | 2 | Installation | 11 |
| <i>Principle of operation</i> | 3 | Servicing | 12 |
| <i>Application and loading</i> | 7 | Insulation resistance test | 13 |

LIST OF ILLUSTRATIONS

| | <i>Fig.</i> |
|------------------------------------------------|-------------|
| <i>Installation details and angular travel</i> | 1 |

LEADING PARTICULARS

| | |
|-----------------------------------------------------------------|----------------------------------------------------------|
| Actuator, Western, ERJ60, Mk. 31F | <i>Ref. No.</i> 5W/2589 |
| <i>Voltage range</i> | 18 to 29V d.c. |
| <i>Normal voltage</i> | 28V d.c. |
| <i>Current consumption</i> | |
| <i>Normal current</i> | 4.2A max. |
| <i>Stall current</i> | 5.5A max. |
| <i>Normal working load</i> | 60 lb. in |
| <i>Maximum working load</i> | 85 lb. in |
| <i>Stalling load</i> | 95 lb. in |
| <i>Maximum static load</i> | 150 lb. in |
| <i>Nominal angular travel</i> | 90 $\begin{smallmatrix} +0 \\ -2 \end{smallmatrix}$ deg. |
| <i>Time for stroke at normal working load and voltage</i> | 1.5 sec. max. |
| <i>Ambient temperature range</i> | -60 to +90 deg. C. |
| <i>Maximum altitude</i> | 60,000 ft. |
| <i>Maximum operating frequency</i> | 120 cycles per hour |
| <i>Electrical connection</i> | |
| <i>Plessey, Mk. 4 miniature (fixed) plug</i> | C.560080 (CZ48995) |
| <i>Weight of actuator</i> | 2½ lb. |
| <i>Flameproof and waterproof</i> | Yes |
| <i>Fireproof</i> | No |

RESTRICTED

Introduction

1. The rotary actuator ERJ60, Mk. 31F, is designed to provide a torque, clockwise or anti-clockwise as necessary, for situations requiring a rotational movement under remote control. It is rated to operate for one minute at a nominal load of 60 lb. in. and with a current consumption not exceeding 4.2 Amp. at that load. Further performance characteristics are given in Leading Particulars.

DESCRIPTION

2. A basic description of the Western Type ERJ60 series of actuators is given in A.P.4343, Vol. 1, Sect. 17, Chap. 1 and Appendix 7.

Principle of operation

3. The actuator is constructed with the motor axis coincident with the axis of the output shaft and produces a rotary motion: it consists basically of a fractional horse power motor, epicyclic gear and an output shaft giving a rotation controlled by two limit switches.

4. The 28 V. d.c. supply to the actuator is disconnected at each end of its rotary travel by these snap-action (limit) microswitches operated by a cam on the output shaft.

5. The motor incorporates an electromagnetic brake to maintain an accurate angle of travel: the brake construction is such that the braking effort is applied as soon as the electrical supply is interrupted, and so ensures the minimum of overrun.

6. The Mk. 31F varies from other actuators in this series, only in the amount of angular travel of the coupling, with its visual indicator and type of electrical plug connection.

Application and loading

7. The snap-action limit switches in the Mk. 31F are adjusted during assembly to

permit 90 degree angular travel of the coupling shaft; this adjustment requires the use of a special test rig and no attempt should be made to alter the setting. Detail of the coupling shaft movement relative to the mounting flange is shown in fig. 1.

8. A functional test should be performed by connecting the actuator to a 28V d.c. supply on no-load, and subsequently applying loads of (a) 30 and (b) 60 lb. in. The maximum current consumption and the time the coupling takes to complete its 90 degree angular travel should not exceed the values given in the following table

TABLE 1

Functional test

| Load in lb. in. | Max. Current in amperes | Time in seconds |
|--------------------|-------------------------------|--------------------|
| No-load | 3.0 | 1.1 |
| 30 | 3.8 | 1.3 |
| 60 | 4.2 | 1.5 |

Further test data is given in the Standard Serviceability Test (S.S.T.) Appendix A.

Electrical connection

9. The electrical connection is by a Mk. 4 Breeze Type, miniature plug Z560080 (CZ48995). The internal wiring connections are identical with those described in A.P.4343, Vol. 1, Sect. 17, Chap. 1 and Appendix 7 dealing with Western Type actuators of the ERJ60 series.

10. Additional information on the operation of the motor and brake assembly and reduction gear train is contained in A.P.4343, Vol. 1, Sect. 17, Chap. 1 and Appendix 3.

RESTRICTED

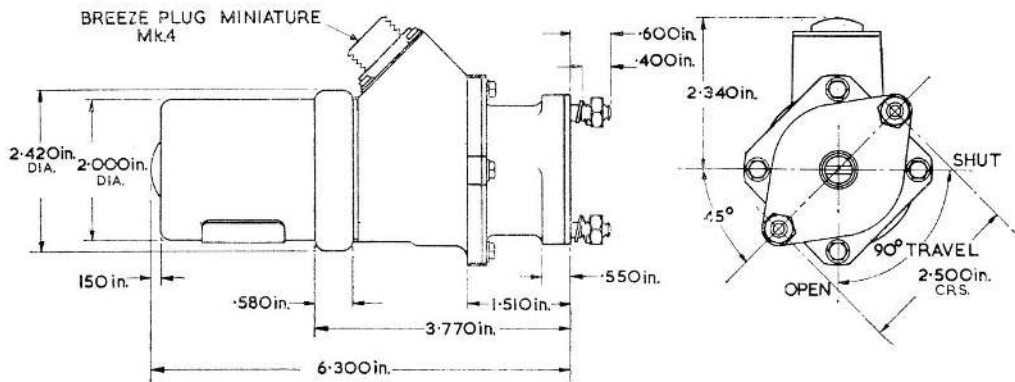

Fig. 1. Insulation details and angular travel

INSTALLATION

11. The actuator is attached to its mounting by means of a flange carrying $\frac{1}{4}$ in. B.S.F. studs on 2.5 in. centres. The drive is transmitted through a slot/tongue connection.

SERVICING

12. Information on simple servicing is contained in A.P.4343, Vol. 1, Sect. 17, Chap 1 and Appendix 7 which refers to the ERJ60

series of actuators, and reference can also be made to the relevant Aircraft Handbook. A Standard Serviceability Test for this actuator is contained in Appendix 'A' to this chapter.

Insulation resistance test

13. The insulation resistance, when measured with a 250V. d.c. insulation resistance tester, between all plug pins and the frame, should not be less than 50,000 ohms (R.A.F.) and 500,000 ohms (R.N.).

Appendix A

STANDARD SERVICEABILITY TEST FOR ACTUATOR, WESTERN, ERJ60, Mk. 31F

Introduction

1. When considered necessary the tests detailed in this appendix may be applied to the above named actuator, immediately prior to installation, or at any time its serviceability is suspect.

Test equipment

2. Information on the rotary actuator test rig required for testing this actuator is contained in A.P.4343S, Vol. 1, Book 2, Sect. 8, Chap. 7 and the test equipment necessary is as follows:—

- (1) Rotary actuator test rig (Ref. No. 4G/6591).
- (2) 250V insulation resistance tester, Type C, (Ref. No. 5G/152).
- (3) Tension gauge (Ref. No. 1H/59).

TEST PROCEDURE

Insulation resistance test

3. Using the insulation resistance tester, measure the insulation resistance between each plug pin and the body, the reading in each instance should not be less than 50,000 ohm.

TESTING

Arc of travel

4. With an opposing load of 2 lb. in. at 28V and normal ambient, temperature, operate the actuator until one limit switch is 'open,' from this position, reverse the direction of rotation and run the motor without pause until the other limit switch is 'open'; the degree of angular movement must be within $90 \begin{smallmatrix} +0 \\ -2 \end{smallmatrix}$ degrees.

Note . . .

Under no circumstances must an assisting load be applied to this actuator.

Cycle test

5. Set the actuator to be tested on the test rig and check that the actuator operates for three cycles within the limits detailed in Table 1.

TABLE 1

| Torque | Voltage | Max. Current (amps) | Time for 90° travel (seconds) |
|------------------|---------|---------------------|-------------------------------|
| no-load CL.O | 28 | 3 | 1.1 |
| no-load ACL.O | 28 | 3 | 1.1 |
| 30 lb. in. CL.O | 28 | 3.8 | 1.3 |
| 30 lb. in. ACL.O | 28 | 3.8 | 1.3 |
| 60 lb. in. CL.O | 28 | 4.2 | 1.5 |
| 60 lb. in. ACL.O | 28 | 4.2 | 1.5 |

CL.O—clockwise load opposing motion.
ACL.O—anti-clockwise load opposing motion.

6. During the preceding tests check that the limit switch indication lamps function correctly: the lamp connection to pin 'D' of the 6-pole plug (one spare pin) indicating "OPEN" and that connected to pin 'A' indicating "SHUT."

7. Perform several inching strokes in each direction to check for satisfactory magnetic brake operation.

Brush gear

8. The brush gear of the motor type SS100, Mk. 21 is accessible by removing the two brush caps. The two brush and (non-adjustable) spring assemblies are held in position on the Commutator by the brush caps which in turn are secured by two 8 B.A. screws. The brush springs exert a pressure on the brushes of $2\frac{1}{2}$ oz. max. to 2 oz. min. when compressed to a length of 0.328 in. The brushes should be renewed when worn 0.05 in. i.e. when the overall length of brush is 0.20 in. instead of 0.25 in.

RESTRICTED

This file was downloaded
from the RTFM Library.

Link: www.scottbouch.com/rtfm

Please see site for usage terms,
and more aircraft documents.

