

## Chapter 35

### ACTUATOR, ENGLISH ELECTRIC, TYPE AE 4512

#### LIST OF CONTENTS

	<i>Para.</i>		<i>Para.</i>
<i>Introduction</i> .....	1	<b>Installation</b> .....	14
<b>Description</b>		<b>Operation</b> .....	15
<i>General</i> .....	2	<b>Servicing</b> .....	17
<i>Motor</i> .....	7	<i>Brush Inspection</i> .....	18
<i>Gearbox and clutch</i> .....	9	<i>Lubrication</i> .....	19
<i>Limit switches</i> .....	13	<i>Angular travel setting</i> .....	20

#### LIST OF ILLUSTRATIONS

	<i>Fig.</i>
<i>General view of actuator Type AE4512</i> .....	1
<i>Installation diagram</i> .....	2

#### LEADING PARTICULARS

<i>Actuator, rotary, Type AE4512</i> .....	<i>Ref. No.</i>
<i>Voltage</i> .....	28V, d.c.
<i>Current consumption (normal load)</i> .....	2.75A
<i>Normal load</i> .....	40 lb. in.
<i>Maximum load</i> .....	60 lb. in.
<i>Time of travel</i> .....	1 sec.
<i>Angle of travel</i> .....	90°
<i>Temperature range of operation</i> .....	-60° C to +90° C
<i>Clutch slip load</i> .....	70 lb. in.
<i>Speed of rotation with normal load</i> .....	15 rev/min
<i>Minimum commutator diameter</i> .....	0.595 in.
<i>New brush length</i> .....	$\frac{7}{16}$ in. (on longest side)
<i>Minimum brush length</i> .....	0.175 in.
<i>Brush grade</i> .....	HAM EGO
<i>Commutator undercut</i> .....	0.012 in.
<i>Electrical connection</i> .....	Breeze plug CZ 28093

RESTRICTED

## Introduction

1. The English Electric Type AE4512 actuator is a 28V. rotary machine designed to provide a 90 degree travel with a normal working load of 40 lb. in, and a maximum working load of 60 lb. in.

## DESCRIPTION

### General

2. The actuator consists of a 2 pole, split series field, 28 volt d.c. motor driving a two stage epicyclic gear train and a right angle worm and wheel through the medium of a double plate friction clutch. Snap action limit switches are incorporated which break the motor field circuit at the end of the travel. Mechanical stops are fitted which positively limit the travel to the specified limits.

3. Damage to the motor or gear train due to accidental overload is prevented by a friction clutch which also absorbs the kinetic energy of the rotating parts when the output shaft comes to rest against the mechanical stops. The output shaft and worm wheel are positioned at 90 degrees to the motor, gearbox and clutch assembly. The three main housings contain the motor, gearbox and limit switches.

4. The motor is a self contained unit consisting of the motor frame which houses the armature, field coils, brush gear and commutator end bearing. The drive end (D.E.) endplate serves to mate the motor to the gearbox and also houses the D.E. bearing of the motor. The brush gear cover is retained in position by two screws, removal of the cover allows access to the commutator and brush gear.

5. The die cast, light-alloy gearbox housing contains the epicyclic gear train, output shaft and bearings, and the mechanical stops which engage with projections on the output shaft to restrict the travel to the desired limits.

6. The die cast limit switch housing contains the limit switches, operating arm, indicator and the electrical connections plug. An alloy diaphragm fitted between the gearbox and limit switch housings prevents the contamination of the limit switch contacts by grease.

### Motor

7. The 28V. d.c. motor is a 2-pole machine with a split series field; the motor is totally enclosed and flameproof. The integral laminated yoke and poles are pressed into the frame. The armature is mush wound

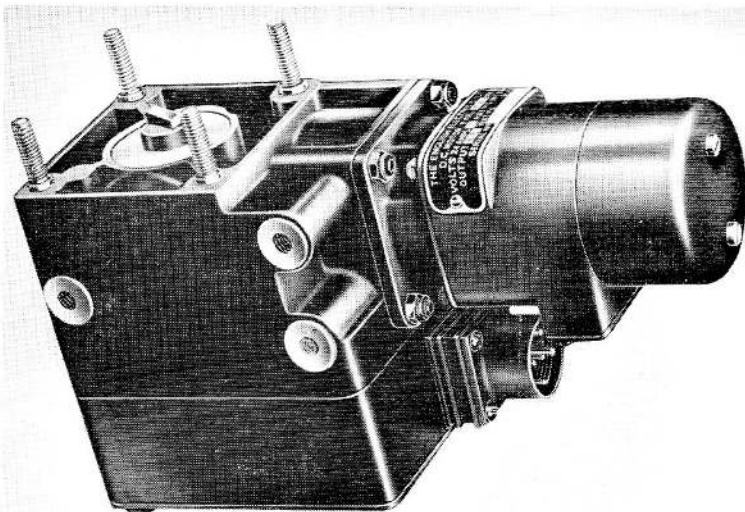

Fig. 1. General view of actuator, Type AE4512

RESTRICTED

with two coils per slot; plain bearings lubricated by oil soaked felt washers support the armature shaft at both ends.

8. The brush gear consists of two carbon brushes located in light alloy brush boxes, which are screwed to a moulded brush rocker. The carbon brushes are kept in contact with the commutator, by a coiled, flat spring which bears on a brush finger. The armature shaft is machined at the D.E. to provide an integral pinion which is the sun gear in the first stage epicyclic train. The supply leads to the motor pass through a slot in the D.E. endplate.

### **Gearbox and clutch**

9. The reduction gear consists of a two stage epicyclic which drives the output shaft through a worm drive. The sun wheel of the first stage is integral with the armature shaft, the second stage sun wheel is integral with the first stage planet carrier. The second stage sun gear is pressed onto the end of the planet carrier extension shaft and secured by means of an axial pin which locates in a hole drilled half in the planet carrier and half in the extension shaft.

10. Each planet carrier assembly consists of three phosphor bronze pinions mounted on flat headed steel pins which are riveted into their respective carriers. A worm is machined on the planet carrier extension shaft, this engages with the worm wheel on the output shaft, which is supported at right angles to the worm axis. The planet carrier extension shaft is supported by two ball bearings; one bearing is secured between a collar machined on the extension shaft and the second planet carrier assembly, the other bearing is secured between a collar machined on the opposite end of the shaft and a locknut on the shaft. Endfloat of the shaft is prevented by a circlip on one side of the bearing and a shim collar and circlip on the other side.

11. The annular gears which mesh with the planet wheels are a sliding fit in the gearbox housing. The base of the annulus gear bore in the housing is machined to form a

shoulder to which a bronze friction ring is pegged, the pegs prevent rotation of the ring. The second annulus gear is fitted adjacent to this ring followed by a friction ring assembly which consists of two bronze friction rings and a spacer pinned together to prevent independent rotation of the friction rings. The first annulus gear is fitted adjacent to the outer bronze friction ring and is prevented from rotating but allowed to slide axially by a pin fitted axially half in the annulus gear and half in the gearbox housing. Pressure between the annulus gears and the friction rings is maintained by springs fitted in the end of the housing. The spring retaining ring forms a location for the motor D.E. endplate spigot. A positive drive exists therefore between the motor and gearbox output shaft; at loads in excess of the specified clutch slip load the second annulus gear slips between the friction rings thereby preventing damage to the actuator. The torque at which the clutch slips may be adjusted by varying the number of springs in the spring retaining ring.

12. Between the driving end of the output shaft and the worm wheel are two stop faces which are machined on the shaft with a definite angular relation to the tongue machined on the D.E. of the output shaft. These stop faces come into contact with mechanical stops when the angular travel of the shaft in either direction has been completed. The mechanical stops are screwed into the bearing at right angles to the output shaft. The adjustment is locked after final adjustment at the completion of manufacture. The limit switch cam is pinned to the output shaft also in correct relation to the tongue drive. An indicator disc is mounted on the same end of the shaft as the limit switch cam.

### **Limit switches**

13. The moulded limit switch assemblies are screwed to clamping plates which are secured to the gearbox housing by two screws. One of the holes in each clamping plate is elongated to provide adjustment of the switches. Terminal inserts are provided



provide indication that the actuator is in either limit position.

### INSTALLATION

14. Five 2 B.A. holes are tapped into the sides of the gearbox to provide mounting points. When the actuator is installed initially the current consumption should be compared with that obtained prior to fitting the actuator to its associated component. The current should not exceed 2.75 amperes when the actuator is installed.

### OPERATION

15. Assuming the actuator is at the limit of travel in either direction of rotation, one limit switch will be open and the other closed, a circuit will be made to the appropriate warning light indicating that the actuator is at the limit position. When a supply is switched on through the closed limit switch, the relevant field is energised and the armature rotates. The drive is transmitted to the output shaft via the gearbox; as soon as the output shaft rotates the other limit switch will close, thus allowing reversal if desired.

16. At a point one degree before the nominal angle of rotation the limit switch operating arm depresses the plunger of the limit switch and the circuit to the motor is broken. The momentum of the moving parts is sufficient to continue rotating the output shaft until one of the stop faces contacts a mechanical stop. The momentum of the rotating mass is then absorbed by the clutch. The operation of the limit switch puts a supply to the indicator light, which illuminates, indicating that the actuator output shaft has reached the limit of travel. The nominal angle of rotation is 90 degrees but the limit switches are set to operate at 88 degrees and the mechanical stops operate at 92 degrees.

### SERVICING

17. Little servicing can be effected whilst the actuator is in service. The current consumption should be checked periodically and the value obtained compared with the figure obtained on installation to provide a general guide to the condition of the actuator. A visual inspection should be made to check for mechanical damage and that all nuts, screws, locking devices and electrical connections are secure and free from corrosion.

#### Brush inspection

18. Access to the brush gear may be gained by removing the cover at the end of the motor housing. The fit of the brushes in the brush box should be ascertained by lifting the brush lever and checking that the brushes slide easily within the box. Any accumulation of carbon dust should be removed using dry compressed air. The minimum brush length is 0.175 in., brushes which will not last until the next servicing period should be replaced. New brushes of the correct grade must be bedded in to attain a contact surface of at least 80 per cent. Remove any carbon dust accumulated during the bedding procedure. The brush spring pressure should be 4 to 5 oz. and this should be checked using a suitable spring balance.

#### Lubrication

19. The actuator is lubricated during manufacture and will not require further inspection until bay servicing is effected.

#### Angular travel setting

20. The mechanical stops are adjusted during manufacture and no attempt must be made to adjust these stops during service.



This file was downloaded from the RTFM Library.

Link: [www.scottbouch.com/rtfm](http://www.scottbouch.com/rtfm)

Please see site for usage terms, and more aircraft documents.

