

## Chapter 4

### ACTUATORS, ROTAX, C1300 SERIES

#### LIST OF CONTENTS

|                             | <i>Para.</i> |   | <i>Para.</i> |
|-----------------------------|--------------|---|--------------|
| <i>Introduction</i> .....   | 1            | <b>Installation</b> .....               | 14           |
| <b>Description</b>          |              | <b>Servicing</b> .....                  | 15           |
| <i>Motor</i> .....          | 2            | <i>Brushgear</i> .....                  | 16           |
| <i>Clutch</i> .....         | 6            | <i>Lubrication</i> .....                | 18           |
| <i>Gearbox</i> .....        | 7            | <i>General</i> .....                    | 19           |
| <i>Auto-switch</i> .....    | 9            | <i>Insulation resistance test</i> ..... | 20           |
| <i>Solenoid brake</i> ..... | 11           |   |              |

#### LIST OF ILLUSTRATIONS

|  | <i>Fig.</i> |
|--|-------------|
| <i>Typical actuator, C1300 series</i> .....      | 1           |
| <i>Sectional view of actuator</i> .....          | 2           |
| <i>Switch operation and wiring diagram</i> ..... | 3           |

#### LIST OF APPENDICES

|   | <i>App.</i> |  | <i>App.</i> |
|---|-------------|--|-------------|
| <i>Actuator, Rotax, Type C1306</i> .....  | 1           | <i>Actuator, Rotax, Type C1311</i> .....   | 3           |
| <i>Actuator, Rotax, Type C1306X</i> ..... | 2           | <i>Actuator, Rotax, Type C1312</i> .....   | 4           |
|   |             | <i>Actuator, Rotax, Type C1313/1</i> ..... | 5           |

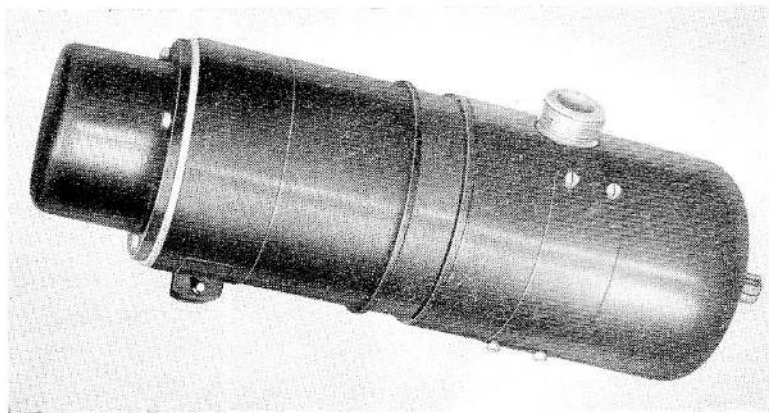
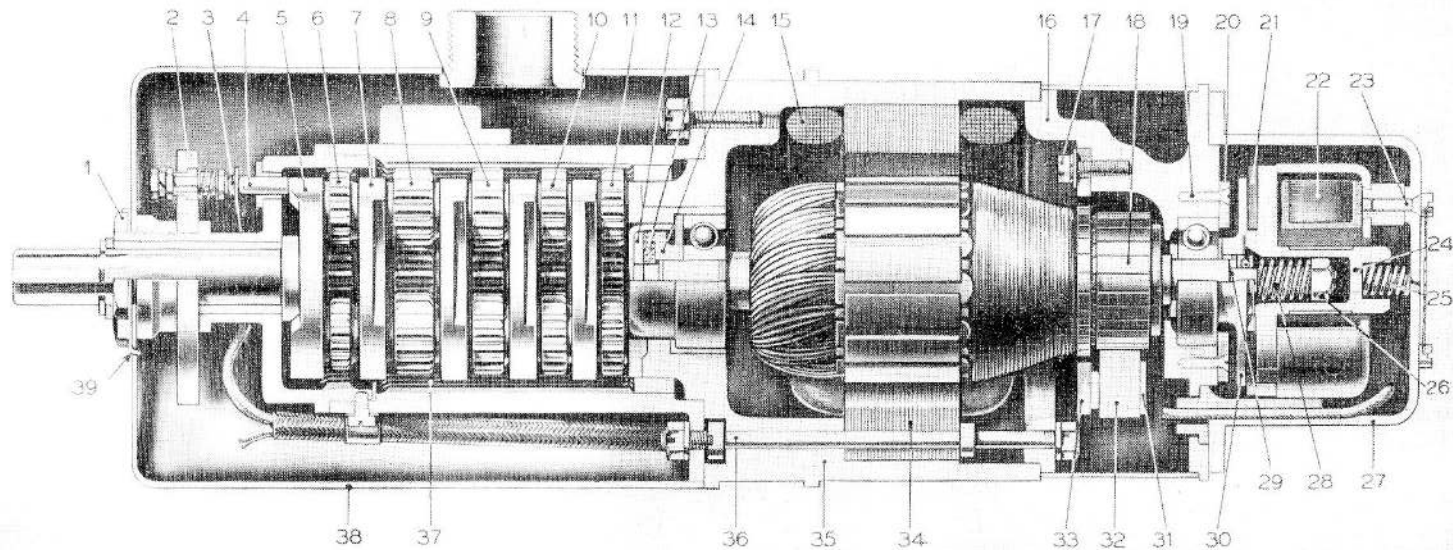

Fig. 1. Typical actuator, C1300 series

**RESTRICTED**

RESTRICTED



- 1 COVER RETAINING NUT
- 2 CONTACT RING
- 3 CONTACT BLADE
- 4 AUTO-SWITCH PLUNGER
- 5 AUTO-SWITCH OPERATING CAM
- 6 PLANET PINION
- 7 PLANET CARRIER
- 8 PLANET PINION
- 9 PLANET PINION
- 10 PLANET PINION
- 11 PLANET PINION
- 12 CLUTCH SPINDLE ASSEMBLY
- 13 CLUTCH LINING

- 14 CLUTCH DISC
- 15 FIELD WINDING
- 16 MOTOR END FRAME
- 17 BRUSH RING SCREW
- 18 COMMUTATOR
- 19 CLAMPING PLATE SCREW
- 20 BEARING CLAMPING PLATE
- 21 BRAKE LINING
- 22 SOLENOID
- 23 COVER SECURING SCREW
- 24 BRAKE SPINDLE
- 25 BRAKE SPRING
- 26 ADJUSTMENT NUT

- 27 SOLENOID COVER
- 28 CLUTCH SPRING
- 29 MOTOR SHAFT
- 30 BRAKE DISC
- 31 BRUSH BOX
- 32 BRUSH
- 33 BRUSH RING
- 34 FIELD CORE
- 35 MOTOR HOUSING
- 36 BOLT
- 37 ANNULAR GEAR
- 38 DUST COVER
- 39 LOCKING WASHER

Fig. 2. Sectional view of actuator

**Introduction**

1. Actuators in the C1300 series are designed for such applications as cowl gill operation. All are basically similar, the differences consisting mainly of variation in clutch setting and minor structural features, though some have no auto-switch fitted. Details of particular types will be found in Appendices to this chapter. ▶

**DESCRIPTION****Motor**

2. The motor is a 2-pole series wound type incorporating a split field, and electrical connections are made from both sections of the field to a switch mechanism located at the end of the epicyclic reduction gears. Change-over from one section of the field to the other, causing a reversal of rotation of the motor, is accomplished by means of the switch which is semi-automatic in action.

3. The field coils and laminated core assembly is a press fit in the motor housing and is secured by two bolts.

4. The armature and commutator are assembled on a hollow shaft which is carried in two ball bearings, one each end of the shaft.

5. The brush boxes are attached to an insulated brush ring which is secured to the commutator end frame by screws.

**Clutch**

6. The drive from the motor to the epicyclic reduction gearing passes through a clutch which consists of a single plate interposed between the motor and the gearbox. The clutch plate is lined and keyed to the armature shaft and rotates at the same speed as the motor. A rod for adjusting the clutch pressure passes through the hollow armature shaft, and adjustment is effected by screwing the nut which varies the tension of the clutch spring controlling the pressure on the clutch plate. Access to the adjusting nut can only be obtained after the solenoid brake assembly has been removed.

**Gearbox**

7. The drive from the motor passes through

a 4-stage epicyclic gear train which gives a reduction in speed of 625 to 1 from the motor to the driving spindle. Each stage consists of three planet pinions which mesh with an annular gear.

8. On those actuators where an auto-switch is incorporated, a further epicyclic gear train, giving an additional 4 to 1 reduction, is fitted to rotate the auto-switch operating cam. When there is no auto-switch incorporated, this additional gear train is not fitted.

**Auto-switch**

9. The auto-switch operates when the driving spindle has reached the end of its allotted angular movement, and stops the motor by automatically cutting off the electrical supply. A switch on the pilot's instrument panel controls the direction of rotation of the driving spindle at any position in its angular travel except at the limit of its travel, when further movement can be only in the reverse direction.

10. Operation of the switch is brought about by the lobes on the operating cam which is driven by the epicyclic gear train. The auto-switch mechanism consists of small spring-loaded levers carrying silver contacts. The outer contacts are stationary and the inner contacts are moved to make connection with them at the correct periods determined by the positions of the lobes on the operating cam. The cam operates plungers which transmit the motion to the inner contacts.

**Solenoid brake**

11. The solenoid operated brake is designed to prevent creepage of the motor after it has been switched off.

12. The solenoid is connected in series with the armature, and the brake remains on until current is passed through the solenoid; this happens immediately the actuator is switched on.

13. The brake disc is keyed to the armature shaft, and adjacent to the disc is the brake spindle, the face of which is lined and makes pressure contact on the face of the brake disc when the motor is switched off.

When the brake solenoid is energized, the brake spindle is drawn away from the disc and the motor is free to rotate. A coil spring, located between the end of the brake spindle and the solenoid cover, provides the pressure on the brake spindle to produce the braking effect.

### INSTALLATION

14. Installation of these actuators should present few difficulties if a suitable mounting and adequate clearance space is provided. Care should be taken to ensure that the fixing strap is between the ribs on the motor housing. It is important to ascertain the angular position of the driving spindle before connecting an actuator to the equipment. For information on the installation of actuators in specific aircraft, reference should be made to the relevant Aircraft Handbook.

### SERVICING

15. These actuators should be serviced in accordance with the general chapter in A.P.4343, Vol. 1, Chap. 17, and the relevant Servicing Schedule.

### Brushgear

16. Brushes should be renewed at periods prescribed in the relevant Servicing Schedule, and whenever examination reveals that they will not remain serviceable for the period that must elapse before the next servicing. They must be renewed when the top of the brush is flush with the brush box.

17. Brush spring pressure should be between 12 and 20 oz., measured with a suitable spring balance.

### Lubrication

18. The bearings are lubricated one third full with grease XG-271 on manufacture; the gear lubricant is grease XG-290, and for other components grease XG-275. Further lubrication should not normally be required except when the actuator is dismantled for repair.

### General

19. The security of all electrical leads should be checked, and the insulation

examined for fraying and damage. The terminals should be examined for security and tightened up as necessary. All nuts, screws and locking devices should be checked for security.

20. The motor should be examined for traces of oil. If any is evident, the source should be investigated and the fault rectified, as oil will cause rapid deterioration of insulation.

### Insulation resistance test

21. The insulation resistance, measured with a 250-volt insulation resistance tester between all live parts and the frame, should be not less than 0.05 megohm.

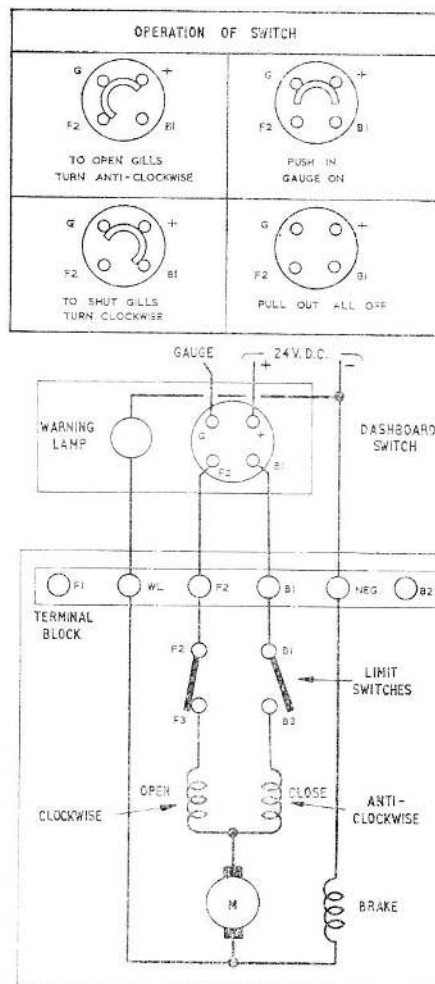

Fig. 3. Switch operation and wiring diagram



## Appendix 2

### ACTUATOR, ROTAX, TYPE C1306X

#### LEADING PARTICULARS

|                                    |       |       |       |       |       |       |       |                               |
|------------------------------------|-------|-------|-------|-------|-------|-------|-------|-------------------------------|
| <b>Actuator, Type C1306X</b>       | ..... | ..... | ..... | ..... | ..... | ..... | ..... | <i>Ref. No. 5W/3425</i>       |
| <i>Voltage</i>                     | ..... | ..... | ..... | ..... | ..... | ..... | ..... | ..... 28V d.c.                |
| <i>Current on load at 29 volts</i> | ..... | ..... | ..... | ..... | ..... | ..... | ..... | ..... 7 amp. (max.)           |
| <i>Maximum load</i>                | ..... | ..... | ..... | ..... | ..... | ..... | ..... | ..... 20 lb. ft.              |
| <i>Clutch setting</i>              | ..... | ..... | ..... | ..... | ..... | ..... | ..... | ..... 24 to 36 lb. ft.        |
| <i>Speed of spindle</i>            | ..... | ..... | ..... | ..... | ..... | ..... | ..... | ..... 12 r.p.m. at 20 lb. ft. |
| <i>Brush spring setting</i>        | ..... | ..... | ..... | ..... | ..... | ..... | ..... | ..... 12 to 20 oz.            |
| <i>Speed of motor (max.)</i>       | ..... | ..... | ..... | ..... | ..... | ..... | ..... | ..... 12,500 r.p.m.           |
| <i>Travel of spindle</i>           | ..... | ..... | ..... | ..... | ..... | ..... | ..... | ..... 940 to 980 deg.         |
| <i>Reduction gear ratio</i>        | ..... | ..... | ..... | ..... | ..... | ..... | ..... | ..... 625:1                   |

1. The actuator, Type C1306X, is generally similar to that described and illustrated in the main chapter. It differs in that the driving end of the armature shaft is drilled and tapped to take a 2 B.A. fixing bolt for a chain sprocket, and the cover fixing nut has been replaced by a spigot nut.

**RESTRICTED**

### Appendix 3

## ACTUATOR, ROTAX, TYPE C1311

### LEADING PARTICULARS

|                                    |       |       |       |       |       |       |       |       |                               |
|------------------------------------|-------|-------|-------|-------|-------|-------|-------|-------|-------------------------------|
| <b>Actuator, Type C1311</b>        | ..... | ..... | ..... | ..... | ..... | ..... | ..... | ..... | <i>Ref. No. 5W/708</i>        |
| <i>Voltage</i>                     | ..... | ..... | ..... | ..... | ..... | ..... | ..... | ..... | ..... 28V <i>d.c.</i>         |
| <i>Current on load at 29 volts</i> | ..... | ..... | ..... | ..... | ..... | ..... | ..... | ..... | ..... 7 amp. ( <i>max.</i> )  |
| <i>Maximum load</i>                | ..... | ..... | ..... | ..... | ..... | ..... | ..... | ..... | ..... 25 lb. <i>ft.</i>       |
| <i>Clutch setting</i>              | ..... | ..... | ..... | ..... | ..... | ..... | ..... | ..... | ..... 20 to 30 lb. <i>ft.</i> |
| <i>Speed of spindle (max.)</i>     | ..... | ..... | ..... | ..... | ..... | ..... | ..... | ..... | ..... 20 <i>r.p.m.</i>        |
| <i>Travel of spindle</i>           | ..... | ..... | ..... | ..... | ..... | ..... | ..... | ..... | ..... 940 to 980 <i>deg.</i>  |
| <i>Brush grade</i>                 | ..... | ..... | ..... | ..... | ..... | ..... | ..... | ..... | ..... <i>CM5H</i>             |
| <i>Brush spring setting</i>        | ..... | ..... | ..... | ..... | ..... | ..... | ..... | ..... | ..... 12 to 20 <i>oz.</i>     |
| <i>Speed of motor (max.)</i>       | ..... | ..... | ..... | ..... | ..... | ..... | ..... | ..... | ..... 12,500 <i>r.p.m.</i>    |
| <i>Reduction gear ratio</i>        | ..... | ..... | ..... | ..... | ..... | ..... | ..... | ..... | ..... 625:1                   |

1. The actuator, Type C1311 (fig. 1), is generally similar to that described and illustrated in the main chapter. It differs in that no dust cover is fitted, and the internal electrical leads are brought out to a terminal block mounted on the gearbox cover. The auto-switch mechanism, which is incorporated in some types, is not fitted in this actuator. A circuit diagram is given in fig. 2.

2. Adjustment of the operating pressure of the solenoid brake is made by means of the adjusting screw on the end of the brake assembly cover.

**RESTRICTED**

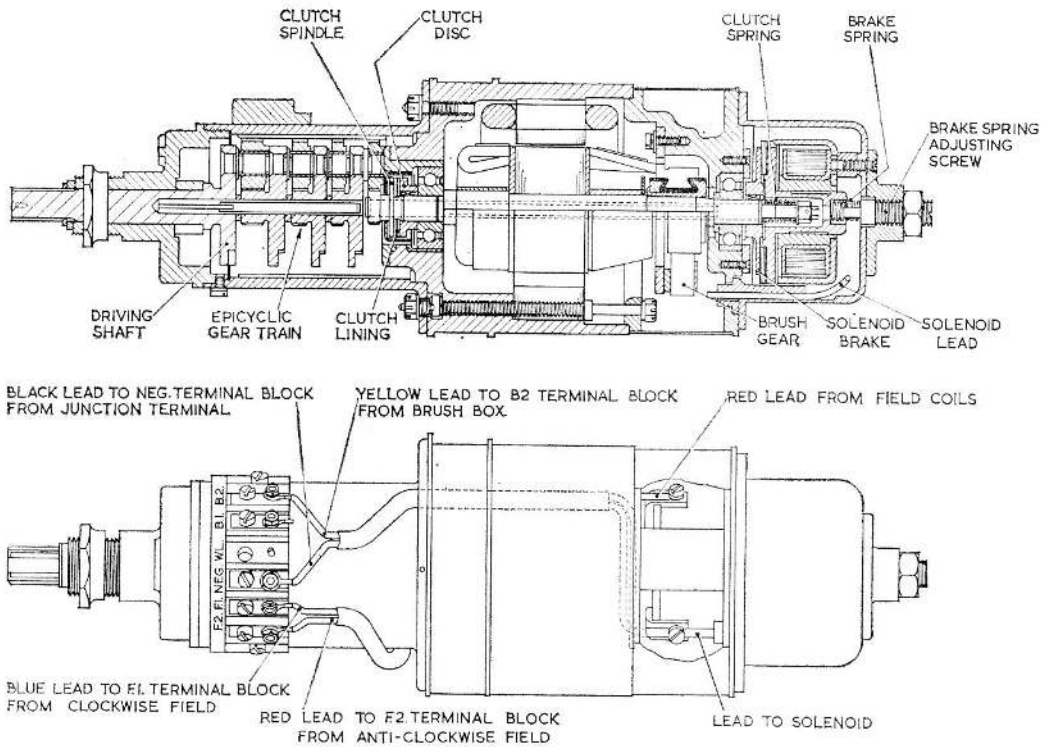

**Fig. 1. Actuator, Type C1311, shown in section**

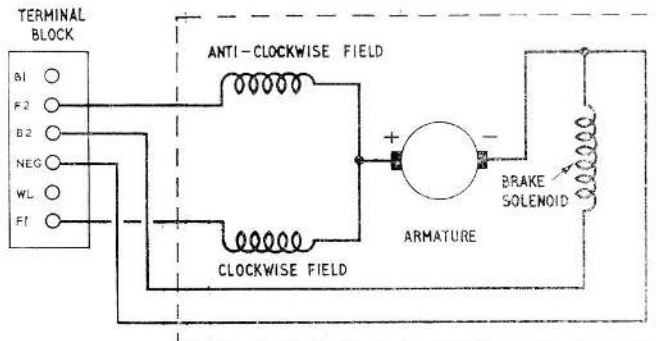

**Fig. 2. Circuit diagram**

**RESTRICTED**

## Appendix 4

### ACTUATOR, ROTAX, TYPE C1312

#### LEADING PARTICULARS

|                                    |       |       |       |       |       |       |       |   |
|------------------------------------|-------|-------|-------|-------|-------|-------|-------|---|
| <b>Actuator, Type C1312</b>        | ..... | ..... | ..... | ..... | ..... | ..... | ..... | <i>Ref. No. 5W/4525</i>                 |
| <i>Voltage</i>                     | ..... | ..... | ..... | ..... | ..... | ..... | ..... | ..... 28V d.c.                          |
| <i>Current on load at 29 volts</i> | ..... | ..... | ..... | ..... | ..... | ..... | ..... | ..... 7 amp. (max.)                     |
| <i>Maximum load</i>                | ..... | ..... | ..... | ..... | ..... | ..... | ..... | ..... 25 lb. ft.                        |
| <i>Clutch setting</i>              | ..... | ..... | ..... | ..... | ..... | ..... | ..... | ..... 40 to 50 lb. ft.                  |
| <i>Speed of spindle</i>            | ..... | ..... | ..... | ..... | ..... | ..... | ..... | ..... 12.5 to 15.5 r.p.m. at 25 lb. ft. |
| <i>Brush spring setting</i>        | ..... | ..... | ..... | ..... | ..... | ..... | ..... | ..... 12 to 20 oz.                      |
| <i>Speed of motor (max.)</i>       | ..... | ..... | ..... | ..... | ..... | ..... | ..... | ..... 12,500 r.p.m.                     |
| <i>Travel of spindle</i>           | ..... | ..... | ..... | ..... | ..... | ..... | ..... | ..... 940 to 980 deg.                   |
| <i>Reduction gear ratio</i>        | ..... | ..... | ..... | ..... | ..... | ..... | ..... | ..... 625:1                             |

1. The actuator, Type C1312, is generally similar to that described and illustrated in the main chapter. It differs in providing greater torque, and in having a higher clutch setting. It is being superseded by Type C1313/1 (Ref. No. 5W/5203).

**RESTRICTED**

## Appendix 5

### ACTUATOR, ROTAX, TYPE C1313/1

#### LEADING PARTICULARS

|                                    |       |       |       |       |       |       |       |   |
|------------------------------------|-------|-------|-------|-------|-------|-------|-------|---|
| <b>Actuator, Type C1313/1</b>      | ..... | ..... | ..... | ..... | ..... | ..... | ..... | <i>Ref. No. 5W/5203</i>                 |
| <i>Voltage</i>                     | ..... | ..... | ..... | ..... | ..... | ..... | ..... | ..... 28V d.c.                          |
| <i>Current on load at 29 volts</i> | ..... | ..... | ..... | ..... | ..... | ..... | ..... | ..... 7 amp. (max.)                     |
| <i>Maximum load</i>                | ..... | ..... | ..... | ..... | ..... | ..... | ..... | ..... 25 lb. ft.                        |
| <i>Clutch setting</i>              | ..... | ..... | ..... | ..... | ..... | ..... | ..... | ..... 30 to 40 lb. ft.                  |
| <i>Speed of spindle</i>            | ..... | ..... | ..... | ..... | ..... | ..... | ..... | ..... 12.5 to 15.5 r.p.m. at 25 lb. ft. |
| <i>Brush spring pressure</i>       | ..... | ..... | ..... | ..... | ..... | ..... | ..... | ..... 12 to 20 oz.                      |
| <i>Brush grade</i>                 | ..... | ..... | ..... | ..... | ..... | ..... | ..... | ..... CM54                              |
| <i>Speed of motor (max.)</i>       | ..... | ..... | ..... | ..... | ..... | ..... | ..... | ..... 12,500 r.p.m.                     |
| <i>Travel of spindle</i>           | ..... | ..... | ..... | ..... | ..... | ..... | ..... | ..... 940 to 980 deg.                   |
| <i>Reduction gear ratio</i>        | ..... | ..... | ..... | ..... | ..... | ..... | ..... | ..... 625:1                             |

1. The actuator, Type C1313/1 (fig. 1), is generally similar to that described and illustrated in the main chapter. It differs in providing greater torque, and in the clutch setting and the pressure of the solenoid brake spring.

RESTRICTED

**RESTRICTED**

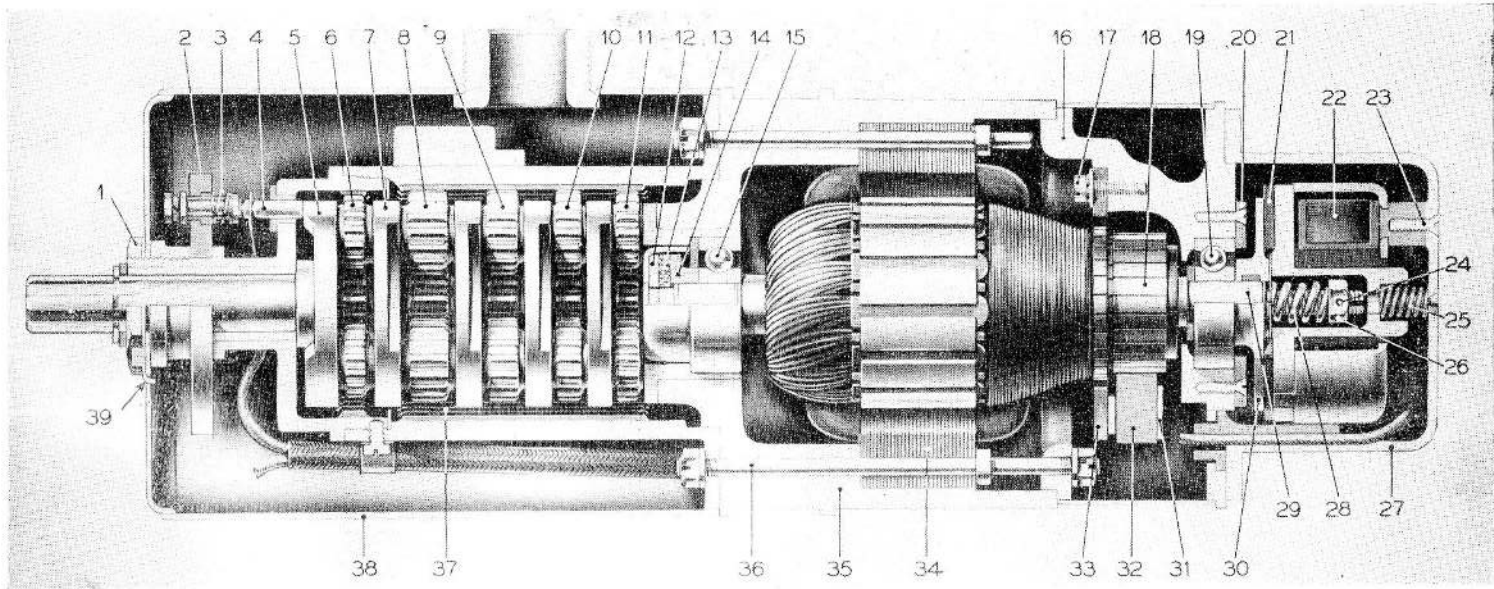

- |                             |                            |                         |                   |
|-----------------------------|----------------------------|-------------------------|-------------------|
| 1 COVER RETAINING NUT       | 11 PLANET PINION           | 21 BRAKE LINING         | 31 BRUSH BOX      |
| 2 CONTACT RING              | 12 CLUTCH SPINDLE ASSEMBLY | 22 SOLENOID             | 32 BRUSH          |
| 3 SPRING                    | 13 CLUTCH LINING           | 23 COVER SECURING SCREW | 33 BRUSH RING     |
| 4 AUTO-SWITCH PLUNGER       | 14 CLUTCH DISC             | 24 PIN                  | 34 FIELD CORE     |
| 5 AUTO-SWITCH OPERATING CAM | 15 BEARING                 | 25 BRAKE SPRING         | 35 MOTOR HOUSING  |
| 6 PLANET PINION             | 16 MOTOR END FRAME         | 26 ADJUSTMENT NUT       | 36 BOLT           |
| 7 PLANET CARRIER            | 17 BRUSH RING SCREW        | 27 SOLENOID COVER       | 37 ANNULAR GEAR   |
| 8 PLANET PINION             | 18 COMMUTATOR              | 28 CLUTCH SPRING        | 38 DUST COVER     |
| 9 PLANET PINION             | 19 BEARING                 | 29 MOTOR SHAFT          | 39 LOCKING WASHER |
| 10 PLANET PINION            | 20 BEARING CLAMPING PLATE  | 30 BRAKE DISC           |                   |

**Fig. 1. Actuator, Rotax, Type C1313/1**

This file was downloaded from the RTFM Library.

Link: [www.scottbouch.com/rtfm](http://www.scottbouch.com/rtfm)

Please see site for usage terms, and more aircraft documents.

