

Chapter 40
ACTUATORS, TEDDINGTON, FJC/A SERIES
(SINGLE SPEED)

LIST OF CONTENTS

	Para.		Para.
<i>Introduction</i>	1	<i>Armature</i>	21
Description	3	<i>Wiring</i>	22
<i>Electrical connection</i>	5	<i>Electro-magnetic brake assembly</i> ..	23
<i>Plug adapter</i>	6	<i>Motor (Teddington type)</i>	26
<i>Housings</i>	7	Operation	30
<i>Reduction gear train</i>	9	<i>Operating performance of individual</i>	
<i>Limit switches</i>	13	<i>actuators</i>	34
<i>Motor (Plessey type)</i>	15	Installation	39
<i>Yoke</i>	18	Servicing	40
<i>Brushgear</i>	19	Bonding test	41

LIST OF ILLUSTRATIONS

	Fig.		Fig.
<i>General view of actuator</i>	1	<i>Sectional view of motor (Plessey type)</i> ..	4
<i>Sectional view of actuator</i>	2	<i>Sectional view of motor (Teddington</i>	
<i>Drive end view of actuator</i>	3	<i>type)</i>	5

LIST OF APPENDICES

	App.
<i>Standard serviceability tests</i>	A (NAVAL)
<i>Standard serviceability tests</i>	A (R.A.F)
<i>Leading particulars</i>	1

Introduction

1. These actuators are designed primarily for use on high temperature installations, such as hot-air valves for anti-icing purposes in aircraft. Some actuators of this design are provided with a heat shield for protection when operating in extra high temperatures, thus increasing the operational ambient temperature range. A typical actuator is described and illustrated in this chapter and details of individual types are given in Appendix 1 to this chapter.

2. The actuator comprises a power unit; this unit includes an electric driving motor, and over-run control electro-magnetic brake, an in-line reduction gear train, and limit switches.

DESCRIPTION

3. The motor of the actuator drives through a gear train to an output shaft, the resultant effect of which is to transmit a rotary motion to operate a hot-air valve. A

RESTRICTED

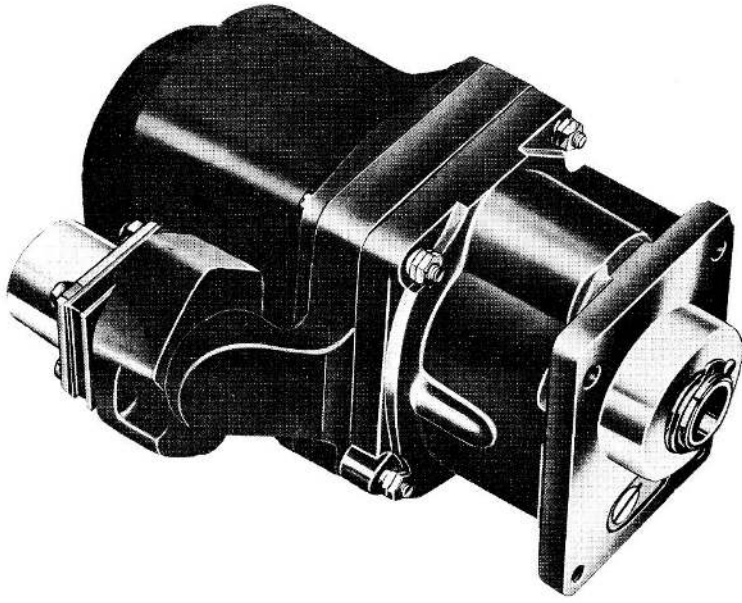

Fig. 1. General view of actuator

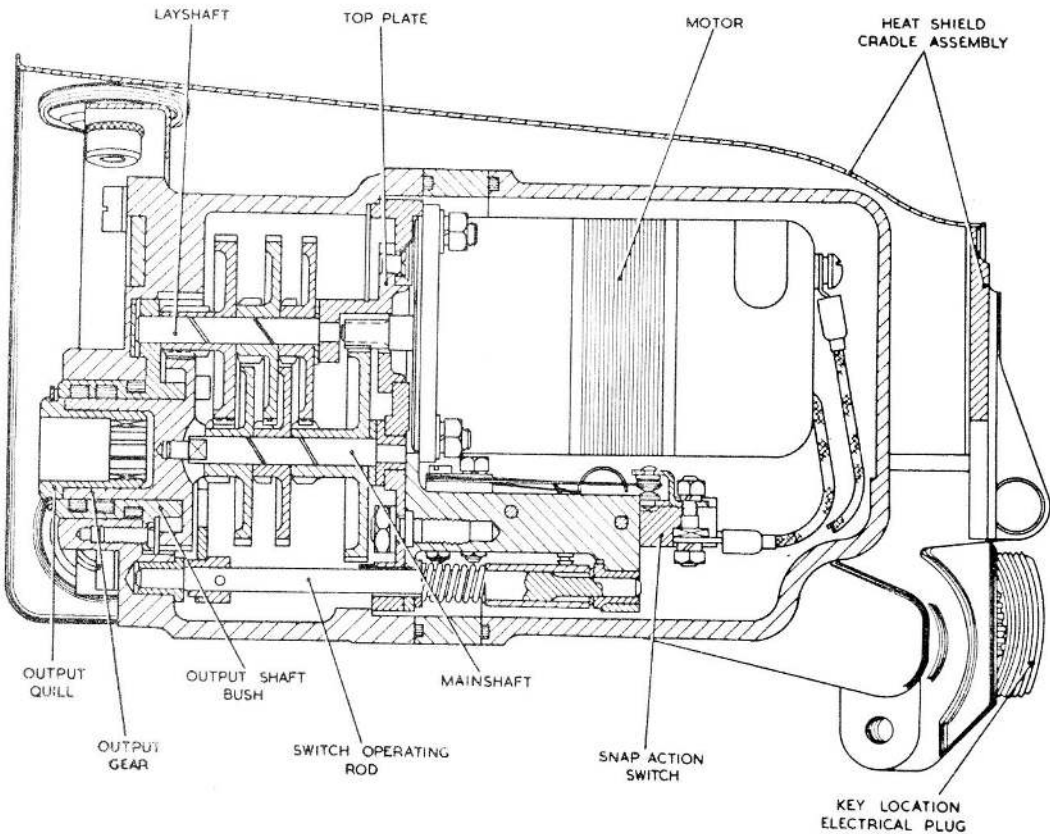

Fig. 2. Sectional view of actuator

RESTRICTED

splined quill provides the mechanical coupling between the output shaft and the ultimate valve movement.

4. The motor is a 28-volt, split series field, reversible, d.c., machine. An electromagnetic brake, which is integral with the motor, eliminates over-run of the output shaft when the electrical supply is discontinued. The brake coil is always in circuit with the armature and one-half of the motor series field, irrespective of the required rotary movement when the control switch is operated. Two snap action switches limit the rotary arc of travel in either direction.

Electrical connection

5. A plug provides the electrical connection to the motor; in some later type actuators a special key location plug is used. The position of the plug relative to the housing depends upon the application of the unit when installed in the aircraft.

Plug adapter

6. The plug socket adapter is a rectangular frame having a groove on one joint face which houses a rubber "O" ring, which seals on the gear housing joint face. Four 4 B.A. clearance holes line up with those on the gear housing face. The plug socket is fitted on a hollow-shaped pedestal, through which the motor and switch leads pass, and is secured by four hex.hd. screws and tabwashers, with a gasket at the mating surfaces. The inner periphery of the plug adapter is smaller than that of the gear housing so that with the top plate in position, this latter is retained by the adapter. Bonding is achieved through a split sleeve located in a counterbored hole in one pair of aligned holes in the plug adapter and gear housing.

Housings

7. The unit which is completely enclosed in an aluminium alloy housing, is sealed against the ingress of moisture, and is designed to withstand a pressure differential

of 20 lb. per. sq. in. The housing is built in two main sections, the gear housing and motor casing, between which is interposed the adapter for mounting the plug.

8. The motor casing is rectangular, closed at one end, with a joint face at the open end. An annular groove on this face provides a seat for a rubber "O" ring, which seals on the mating face of the plug adapter frame. At each corner of the open end a drilled boss houses a special 4 B.A. ch.hd. screw, which passes through the plug adapter frame and gear housing flange. The motor casing, plug adapter, and gear housing, are clamped together and held on to the special screws by appropriate nuts and spring washers.

Reduction gear train

9. The reduction gear train is carried on two parallel shafts on which the pinion and gear assemblies are disposed alternately. The main shaft is supported between a bush fitted to the internal face of the top plate, and in a machined recess and blind hole in the output shaft. The output shaft is carried in a flanged phosphor-bronze bush, which is housed on a mounting spigot at the gear housing closed end, and has an integral spur wheel which meshes with the stage

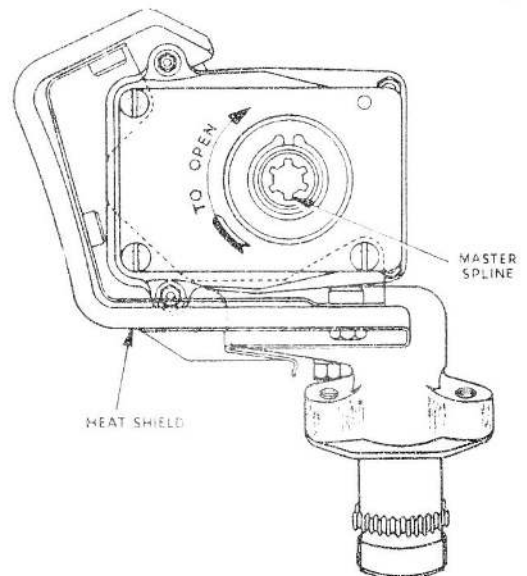

Fig. 3. Drive end view of actuator

below pinion. Two "O" rings in grooves in the bore of the bush provide a seal between bearing and shaft. The bush is secured at its flange to the inside of the gearbox by three screws. An "O" ring seal is also fitted between the bush and gear housing.

10. Fitted to the flange of the output shaft bush is a locking pin with a slot machined diametrically across it; this slot fits over, and traps a blade located in a recess in the gear housing. The blade also lies across a hole in the flange, and the layshaft passes through this hole, with its slotted end engaging the blade, to prevent rotation. In the design of some later type actuators, no locating blade is fitted. The other end of the layshaft fits into a bearing which is flange-fitted to the internal face of the top plate and secured by three csk. hd. screws. The centre of the bearing flange has a clearance hole through which the gear cut shaft of the motor passes.

11. Both gear shafts are shimmed at the journal ends to control axial movement of the pinion and gear assemblies. The top plate has four screws which pass through it and are secured by special round nuts. The screws have eccentric heads which fit in similar counterbored holes in the internal face of the plate, thus holding them captive. The motor is retained on these screws by plain nuts and spring washers, and the drive shaft protrudes through the top plate to engage with the first-stage gear.

12. The output gear shaft has a quill coupling fitted to it, which is located by a dog and slot arrangement, and retained in position by a circlip. A spacing washer and shims, to control end-play, are interposed between the circlip and the face of the mounting spigot. The gearbox top plate has an angled arm, cast integral with the face opposite the gear assembly. In the design of some later actuators, the angled arm is a non-integral component and is retained by a stud and nut. A switch operating rod lies parallel to this arm, and locates in a bush in the angled portion. A butterfly

shaped plate, splined-fitted to that section of the operating rod, forms the limit switch trip lever. The arms of the plate are saw-cut, and a ch.hd. screw fitted to each, causes the lever to impart a grip on the operating rod, and on two grub screws which form adjusting screws for switch operation. The clamping screws are locked by spring washers. A coil spring interposed between the operating lever and the gearbox top plate, bears on a washer at the latter, and controls end-float of the operating rod.

Limit switches

13. Two snap-action limit switches are fitted to the support arm by two 6 B.A. hex.hd. bolts, nuts, and spring washers, so that their operating plungers lie immediately above the grub screws on the switch lever. One of the retaining bolts carries one cable cleat at its head, and two cable cleats at the nut end of the bolt, whilst the remaining bolt has plain washers at these positions. A fork-ended leaf spring located in a groove on each switch plunger is secured by a single 6 B.A. bolt, nut, and spring washer. The bolt head locates in a slot in the switch support arm. The leaf springs bias the plungers in the extended position. In the design of some later type actuators, no fork-ended leaf spring is fitted, the snap-action limit switch springs have also been strengthened.

14. The switch operating rod has a "V" shaped trip lever pinned to it, at its gearbox end. The arms of the trip lever are finished hard chromium plate; these are engaged on, and operated by, two pins riveted to the face of the output shaft gear, at either extreme of travel.

Motor (*Plessey type*)

15. The motor is designed for operation from a 28-volt d.c. supply, and has split series field windings for reversible operation. The drive end incorporates an electromagnetic brake mechanism, the coil of which is in series with the armature. Braking

action is thus automatically applied to the armature when the motor is de-energized.

16. The motor comprises four main units, the brake housing with mounting flange integral and brake components, the yoke which carries the field system, the brushgear housing and brushgear, and the armature assembly. The armature is supported by ball bearings located in the brushgear and brake housings.

17. The drive-end bearing is located within the web of the brake housing and held in position by a retaining plate. A 0.005 in. shim is interposed between the outer race and the housing, and end-play is taken up by shims between the bearing and its retaining plate. The commutator-end bearing is located in the web of the brushgear housing.

Yoke

18. The pole pieces are integral with the yoke, the whole being built up from suitable stampings, and the two through bolts which are integral with the brake

coil assembly pass within the yoke assembly and between the field coils; these coils encircle the polepieces and are held against the interior of the yoke by wedges passing through the pole pieces.

Brushgear

19. The brushgear housing locates on the yoke assembly in like manner to the brake housing; the former encloses the brushgear carrier. The two brush holders are secured to a moulded annulus. An insulating washer lies between the carrier and the housing web; the carrier is secured to the web by two screws which thread into nut-plates. These plates are restrained within projections on the moulding so that the annulus may be rotated through an arc, in order to obtain the required commutating position. A second hole in the nut-plates, and two corresponding holes in the housing, permit the two through bolts of the brake coil assembly to protrude beyond the housing. Nuts threaded on to these secure the two housings and yoke together.

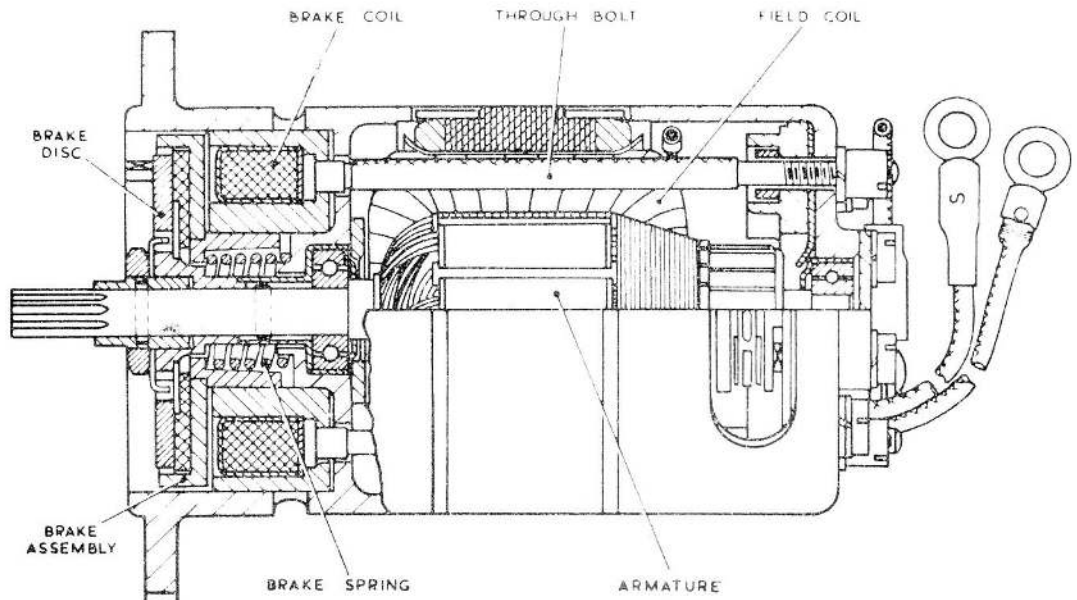

Fig.4. Sectional view of motor (Plessey type)

RESTRICTED

20. The carbon brushes are a loose fit in machined brass holders, and held under a pressure of $3\frac{1}{2}$ to $4\frac{1}{2}$ oz. by means of clocktype springs and levers. Bushes on the brush carrier protrude through slots in the housing and carry terminal screws.

Armature

21. The commutator is of moulded construction. The shaft journals are ground to close limits, and the bearings are selectively assembled to obtain the necessary fit. The drive pinion is integral with the armature shaft.

Wiring

22. The connection common to the field coils and brake coil is an internal one. The two flying leads are the connections to the field coils (*fig.4*), the third connection being taken from the appropriate brush terminal. All windings are impregnated.

Electro-magnetic brake assembly

23. The brake disc is secured against its driving pin on the armature shaft by a special nut; this nut threads on to a short collar which is a sliding fit on the shaft, but which is prevented from moving on the shaft by a pin passing through both shaft and collar. The brake disc is counter-bored to accept a portion of the collar, and is provided with holes for the outer tabs of the locking washer, held beneath the nut.

24. Behind the brake disc is a floating annulus called the attraction plate; this plate carries the friction lining, and is restrained against rotation by two projecting lugs at its periphery, which pass into corresponding slots in the brake housing. The inner diameter of the attraction plate is such that it clears the armature shaft, and it is located axially between the brake disc attached to the armature shaft and the brake coil assembly, enclosed within the brake housing.

25. A coil spring, embracing the armature shaft and co-axial with it, butts against the bearing housing at one end, and the attraction plate at the other, thus forcing the latter into contact with the brake disc. The brake is housed in an annulus of "U" section, and is held by two long diametrically opposed studs against the web of the brake housing. "U" shaped brake adjustment shims are interposed between brake coil housing and web, in order to obtain the required brake clearance. Upon energizing the motor, the annulus is attracted to the brake coil housing, and clear of the brake disc, against the action of the brake coil or flat dished spring. The armature is then free to rotate. On de-energizing the motor the loaded brake spring extends the annulus against the brake disc, and the machine stops with a minimum of over-run.

Motor (Teddington type)

26. The motor is encased in a light-alloy tubular housing, closed at one end by a cylindrical brake coil housing, and at its other end by a spigotted, square flanged end plate. The sections are secured together by two long bolts one end of which screws into the coil housing and the other end passes through the end plate to be retained by round nuts.

27. The armature spindle is supported by ball races inset into the inner faces of the coil housing and the end plate where they are retained by plates bolted to the faces. The commutator locates at the coil housing end and the associated carbon brushes are carried in square section boxes attached to a circular plate assembled over the long bolts. The field stack is also assembled over these bolts and separated from the brush carrier by spacer tubes. The stack has two separate series windings, one for clockwise and the other for anti-clockwise rotation. It is retained in position by round nuts fitted internally over the bolts.

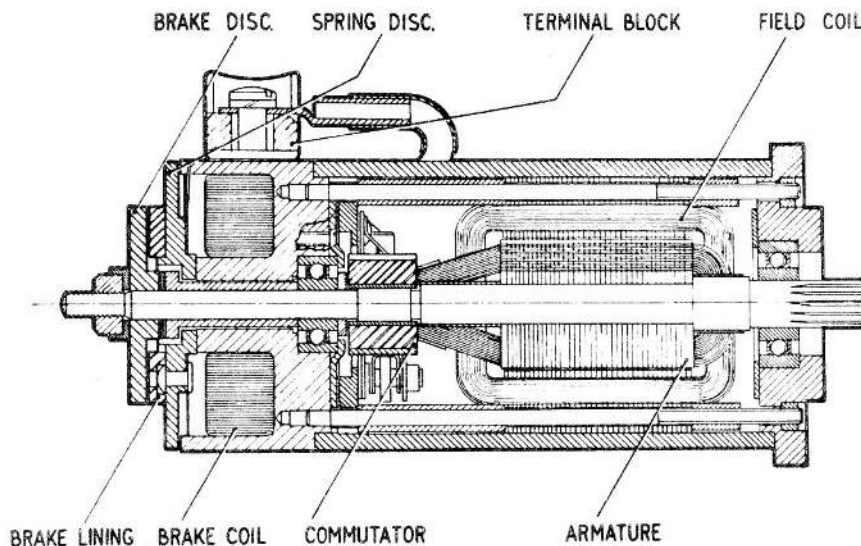

Fig. 5. Sectional view of motor (Teddington type)

28. The outer face of the coil housing is recessed to house the brake coils, one a shunt winding for connection across the armature and the other, a series winding for connection in series with it. The splined armature spindle extends beyond this housing and carries a brake disc, secured on its outside by a nut and tabwasher and separated from the housing on its inside by a spacer tube over the spindle. Between this disc and the housing is a brake assembly with a ring of brake lining bonded to its outer face. In the static condition a spring disc which is riveted to the rear of the brake assembly and has fingers which locate in slots in the end of the coil housing, loads the brake lining against the brake disc. Energization of the motor and the brake coils withdraws the brake assembly away from the disc.

29. The gear cut end of the armature spindle passes through the end plate, the corners of its flange being drilled for mounting purposes. A three-way terminal block is fitted to the outside of the coil housing.

OPERATION

30. In the full travel position one limit switch is held open by the switch operating lever. This condition causes the brake solenoid and one field winding to be open circuited.

31. When the control switch, which may be manual or automatic, selects opposite travel, the brake solenoid and remaining field winding are simultaneously energized pulling the brake disc from the friction pad against the action of the brake spring, thereby allowing the motor armature to rotate and drive the gear train. The movement of the final gear causes that pin which was bearing on the trip lever arm to rotate the operating rod; this in turn, allows the switch lever to depress the plunger, and break the circuit to the field winding and brake solenoid. The armature is therefore arrested by the application of the brake under the influence of its return spring.

RESTRICTED

32. The reverse selection of the control switch will effect full travel in the opposite direction by a similar action as given in the previous paragraph.

33. It will be seen that the contacts on both limit switches are closed in all positions between full travel, in order that the actuator may be operated in either direction between the limits of travel.

Operating performance of individual actuators

34. To clarify the position of operating times of pre-Mod 562 and Mod 606 Teddington type actuators, the following information is promulgated to avoid confusion.

35. Actuators whose operating time is 8 to 15 seconds are those actuators pre-Mod 562 and/or suffixed with the letter 'T' the differences are as follows:-

(1) Suffix 'T' and pre-Mod 562 refer to Teddington Type actuators, sub-contracted out to Western Manufacturing (Reading) Ltd.

(2) Actuators embodying Mod 562 are those whose serial Nos. have no suffix 'T'.

(3) Actuators embodying Mod. 606 are those identified by a serial number with a suffix 'T'.

36. Mod 562 introduced a 48 D.P. Gear-box and double "O" ring seal, to increase output torque and generally improve design.

37. Mod 606 introduced stiffened output shaft with radiused slots, to prevent possibility of cracking in sharp corners of slots.

38. Table 1 of Appendix 1 gives a clear picture of the different operating times of actuators pre-Mod. 562 and suffixed 'T'. Mod. 562 and Mod 674.

INSTALLATION

39. The actuator is mounted on four 2 B.A. studs which pass through clearance holes drilled in the gear housing mounting flange, and is located by the spigot machined on the mounting face. Before mounting to the valve to be controlled it is most important to check that the arc of rotation of the actuator is identical in sense and direction to that of the unit to which it is to be coupled.

SERVICING

40. These actuators should be serviced in accordance with the general chapter in A.P.4343, Vol.1, Sect.17, Chap.1, and the instructions in the relevant Servicing Schedule. Dismantling instructions for actuators will be found in A.P.4343D, Vol.6, Book.5, Sect.16, Chap.40.

Bonding test

41. Measure the resistance between the body of the electrical plug and the gear-box with a Bonding tester, Type B (Ref. No. 5G/2126). The resistance must not exceed 0.05 ohms.

Appendix 1

LEADING PARTICULARS

Table 1

Actuators Type FJC/A/	Operating time in seconds	Applied Torque in lb in.	Maximum current consumption in amperes.	Minimum operating voltage in volts	Rotary arc of travel in degrees
ACTUATORS TO PRE MOD. 562 AND SUFFIXED 'T'					
10, 11, 12, 14, 17, 19, 26, 32, 36, 37, 43, 86, 13, 20, 25	+0 15-7	120	1.3	16	+0 180-2
	+0 3-0.5	60	1.9	16	+0 180-2
ACTUATORS TO MOD. 562 STANDARD					
10, 11, 12, 14 26, 32, 36, 37, 43	+4 15-2	120	1.3	16	+0 180-2
13, 20, 25,	3-0.5	60	1.9	16	+0 180-2
17	+4 15-2	140	1.3	16	+0 180-2
19	+4 15-2	180	1.3	16	+0 180-2
ACTUATORS TO MOD. 674 STANDARD AND AFTER					
13, 20, 25, 910	3±0.5	120	2.5	16	+0 180-2
52	60+30	180	1.3	16	+0 180-2
54, 82, 92, 904	+4 15-2	120	1.65	16	+0 180-2
56	5±1 minutes	180	1.5	21	+0 180-2
58, 63	+4 15-2	120	1.3	16	+0 180-2
67	+1 4-0.5 minutes	180	1.75	21	+0 140-2

RESTRICTED

Table 1. (continued)

Actuators Type FJC/A/	Operating time in seconds	Applied Torque in lb in.	Maximum current consumption	Minimum operating voltage in volts	Rotary arc of travel in degrees
73	2±0.5	40	2.0	16	90±3
74	1.5±0.5	120	3.25	16	+0 90-2
85	+4 15-2	120	1.3	16	+0 180-2
86	+4 15-2	120	1.3	16	+0 180-2
91	15±3	40	0.8	16	90±3
96	2 max.	50	1.65	18	+0 90-2
98	90 min,	120	1.75	21	+0 140-2
900	+0.5 3-1.5	120	2.5	16	+0 90-2
906	60+30	120	1.3	16	+0 180-2
909	+4 15-2	120	1.3	16	+0 180-2
912	45±8	180	1.3	16	+0 90-2
PRE MOD 907					
915	+10 60-5	180	1.3	16	+0 90-2
TO MOD 907 AND 912 STANDARD					
915	100±20	60	1.3	16	+0 180-2
916	+0.5 3-1.5	120	2.5	16	+0 90-2
917	1.5±0.5	30	2.0	16	90±3
919	+4 15-2	120	1.3	16	+0 180-2

RESTRICTED

Actuators Type FJC/A/	Operating time in seconds	Applied Torque in lb in.	Maximum current consumption	Minimum operating voltage in volts	Rotary arc of travel in degrees
929	+0 15-5	120	1.3	16	+0 90-2
930	+30 60-0	120	1.3	16	+0 180-2
946	90±15	120	1.3	16	+0 90-2
953	+10 28-5	100	1.65	16	+0 180-2
957	100±20	60	1.3	16	+0 180-2
958	+0 15-5	120	1.3	16	+0 90-2
960	2.5±0.5	40	2.0	16	90±3
961	1.5±0.5	30	2.0	16	90±3
962	+10 25-5	180	1.65	16	+0 180-2
963	+30 90-0	120	1.3	16	+0 180-2
966	+0.5 3-1.5	120	2.5	16	+0 90-2
968	+0 15-5	120	1.3	16	+0 90-2
969	+30 60-0	120	1.3	21	+0 180-2
980	+0 15-5	120	1.3	16	+0 90-2
981	+30 60-0	180	1.3	16	+0 180-2

RESTRICTED

Table 2
(Quick reference table)

Type FJC/A/	Ref. No.	Ambient temp. range.	Type of motor	Remarks
10	5W/425	-55 to 150 ⁰ C	CZ.67427 (5W/2056)	Circuit diagram A
11	5W/387	-55 to 150 ⁰ C	CZ.67427 (5W/2056)	Circuit diagram A
12	5W/386	-55 to 150 ⁰ C	CZ.67427 (5W/2056)	Circuit diagram A
13	5W/384	-55 to 150 ⁰ C	4CZ.93327	Circuit diagram B
14	5W/383	-55 to 150 ⁰ C	CZ.67427 (5W/2056)	Circuit diagram C
17	5W/715	-55 to 150 ⁰ C	CZ.67427 (5W/2056)	Circuit diagram B
19	5W/979	-55 to 150 ⁰ C	CZ.67427 (5W/2056)	Circuit diagram B
20	5W/716	-55 to 150 ⁰ C	4CZ.93327	Circuit diagram B
25	5W/434	-55 to 150 ⁰ C	4CZ.93327	Circuit diagram C
26	5W/2083	-55 to 150 ⁰ C	CZ.67427 (5W/2056)	Circuit diagram A
32	5W/2833	-55 to 150 ⁰ C	CZ.67427 (5W/2056)	Circuit diagram B
36	5W/385	-55 to 150 ⁰ C	CZ.67427 (5W/2056)	Circuit diagram E
37	5W/426	-55 to 150 ⁰ C	CZ.67427 (5W/2056)	Circuit diagram E
43	5W/1028	-55 to 150 ⁰ C	CZ.67427 (5W/2056)	Circuit diagram E
52	5W/991	-55 to 150 ⁰ C	CZ.67427 (5W/2056)	Circuit diagram B
54	5W/2074	-20 to 200 ⁰ C	4CZ.92200 (5W/2822),	Circuit diagram D Fitted with key location plug. Fitted with heat shield Locating blade not fitted Output shaft bush secured to gear housing by 3 ch. hd. screws. The angle arm at the gearbox top plate is a non-integral component and is retained by a stud and nut. Fork ended leaf spring not fitted Plug adapter secured by two studs and nuts.

RESTRICTED

Type FJC/A/	Ref. No.	Ambient temp. range	Type of motor	Remarks
56	5W/2639	-55 to 150°C	4CZ/92197	Circuit diagram B. Locating blade not fitted. Output shaft bush secured to gear housing by 3 ch. hd. screws. The angle arm at the gearbox top plate is a non-integral component, and is retained, by a stud and nut. Fork end leaf spring not fitted. Plug adapter secured by two studs and nuts.
58	5W/975	-55 to 150°C	CZ.67427 (5W/2056)	Circuit diagram F
63	5W/1108	-55 to 150°C	CZ.67427 (5W/2056)	Circuit diagram D
67	5W/2597	-55 to 150°C	4CZ.92197	Circuit diagram B
73	5W/1354	-55 to 150°C	FJA/A/51	Circuit diagram C
74	5W/4257	-60 to 150°C	4CZ.93327	Circuit diagram B.
82	5CW/4156	-55 to 150°C	4CZ.94690	Circuit E. Fitted with key location plug.
85	5W/2567	-55 to 150°C	CZ.67427 (5W/2056)	Circuit diagram D. Fitted with key location plug. Plug adapter secured by two studs and nuts.
86	5W/2568	-55 to 150°C	CZ.67427 (5W/2056)	Circuit diagram E. Fitted with key location plug. Plug adapter secured by two studs and nuts.
91	5W/	-55 to 150°C	FJA/A/46	Circuit diagram C
92	5W/2598	-20 to 200°C	4CZ.92200 (5W/2822)	Circuit diagram E. Fitted with key location plug. Fitted with heatshield. Locating blade not fitted. Output shaft bush secured to gear housing by 3 ch. hd. screws. The angle arm at the gearbox top plate is a non-integral component and is retained by a stud and nut. Fork ended leaf spring not fitted. Plug adapter secured by two studs and nuts.
96	5W/2742	-55 to 150°C	CZ.67427 (5W/2056)	Circuit diagram G. Fitted with key location plug. Fitted with indicator switch which opens when actuator reaches fully open position.
98	5W/	-55 to 150°C	4CZ.92197	Circuit diagram B
900	5W/2789	-55 to 150°C	4CZ.93327	Circuit B
904	5W/3576	-20 to 200°C	4CZ.92200 (5W/2822)	Circuit diagram D. Fitted with key location plug. Fitted with heat shield. Locating blade not fitted. Output shaft bush secured to gear housing by 3 ch. hd. screws. The angle arm at the gearbox top

RESTRICTED

Table 2. (continued)

Type FJC/A/	Ref. No.	Ambient temp. range	Type of motor	Remarks
				is a non-integral component and is retained by a stud and nut. Fork end leaf spring not fitted. Plug adapter secured by two studs and nuts.
906	5W/2835	-55 to 150°C	CZ.67427 (5W/2056)	Circuit B
909	5W/2832	-55 to 150°C	CZ.67427 (5W/2056)	Circuit C
910	5W/2834	-55 to 150°C	4CZ.93327	Circuit C
912	5W/3588		CZ.67427	Circuit B.
915	5W/2774	-55 to 150°C	4CZ.94690	Circuit B
916	5W/4672		4CZ.93327	Circuit diagram B, but using Cannon plug, Type MS-3102A,-14S-5P.
917	5W/4381	-40 to 150°C	FJA/A/88	Circuit diagram B, but using Cannon plug, Type MS-3102E-14S-5P.
919	5W/2831	-55 to 150°C	CZ.67427 (5W/2056)	Circuit C
929	5W/4163	-55 to 150°C	CZ.67427 (5W/2056)	Circuit B
930	5W/3891	-55 to 150°C	CZ.67427 (5W/2056)	Circuit C
946		-55 to 150°C	4CZ.92197	Circuit B
953	5W/5641	-50 to 55°C	4CZ.94690	Circuit diagram A.
957	5W/4264	-40 to 200°C	4CZ.95050	Circuit diagram B, but using plug, Type 2CZ.85945.
958	5W/4382	-65 to 70°C	CZ.67427	Circuit diagram B.
960	5W/5995	-40 to 100°C	FJA/A/51	Circuit diagram B, but using Cannon plug, Type MS-3102E-14S-5P.
961	5W/4160	-60 to 70°C	FJA/A/88	Circuit diagram C, but using Cannon plug, Type MS-3102-14S-6P.
962	5W/6224	-50 to 55°C	4CZ.94690	Circuit diagram B, but using plug, Type 2CZ.85945.
963	5W/	-55 to 200°C	4CZ.94690	Circuit diagram J.
966	5W/5115		4CZ.93327	Circuit diagram B, but using Cannon plug, Type MS-3102A-14S-5P.
968	5W/6015	-30 to 100°C	4CZ.67427	Circuit diagram H.
969	5W/5670		4CZ.94690	Circuit diagram B.
980	5W/	-40 to 70°C	CZ.67427	Circuit diagram B, but using Cannon plug, Type MS-3102E-14S-5P.
981	5W/5120	-55 to 150°C	CZ.67427	Circuit diagram B.

RESTRICTED

Type of Motor	CZ67427	4CZ92197	4CZ92200	4CZ93327	4CZ94690	FJA/A/46	FJA/A/51	501/1/05074	4CZ95050	FJA/A/88
Type of brush	SW/1041	SW/1041	SW/1041	SW/1041	SW/1041	FJA.350	FJA.350	CZ62177	CZ.62177	FJA.350
New brush length (in)	0.385	0.385	0.385	0.385	0.385	0.230	0.230	0.385	0.385	0.230
Minimum brush length (in)	0.25	0.25	0.25	0.25	0.25	0.090	0.090	0.25	0.25	0.090
Brush spring pressure (oz) (gm)	3.5 - 4.5 100 - 125	3.5 - 4.5 100 - 125	3.5 - 4.5 100 - 125	3.5 - 4.5 100 - 125	3.5 - 4.5 100 - 125	1.26 - 1.40 36 - 40	1.26 - 1.40 36 - 40	3.5 - 4.5 100 - 125	3.5 - 4.5 100 - 125	1.26 - 1.40 36 - 40
Commutator										
New diameter (in)	0.49	0.49	0.49	0.49	0.49	0.380	0.380	0.49	0.49	0.380
Minimum diameter after skim for re-use	0.45	0.45	0.45	0.45	0.45	0.370	0.370	0.45	0.45	0.365
Mica width (in)	0.024-0.026	0.024-0.026	0.024-0.026	0.024-0.026	0.024-0.026	0.016 - 0.018	0.015 - 0.018	0.024 - 0.026	0.024 - 0.026	0.016 - 0.018
Mica undercut (in)	0.020-0.025	0.020-0.025	0.020-0.025	0.020-0.025	0.020-0.025	0.022-0.027	0.022 - 0.027	0.020 - 0.025	0.020 - 0.025	0.022 - 0.027
Type of bearings										
Drive end	Hoffman 4666	Hoffman 4666	Fisher FB 2718 3 Dot	Hoffman 4666	Fisher FB 2718 3 Dot	Emarco BR 8/16 Grade C 206	Emarco BR 8/16 Grade C 206	Fischer 501/4/05423	4Z.42273	Bardeen R3S3 0-11
Commutator End	Hoffman N 463	Hoffman N 463	Fisher FB 2743 3 Dot	Hoffman N 463	Fisher FB 2742 3 Dot	Emarco BR $\frac{1}{4}$ B.P. Grade C 256	Emarco BR $\frac{1}{4}$ B.P. Grade C 256	Fischer 501/1/05113	4Z.42274	Emarco BR $\frac{1}{4}$ B.P. Grade C 256
Bearing grease	DTD 900-4342	DTD 900-4342	DTD 900-4342	DTD 900-4342	DTD 900-4342	Oil OX - 14	Oil OX - 14	Aero-Shell 15	Aero-Shell S3739 Spec. No. DTD 900/43/42	Aero-Shell S.3739 Spec. No. DTD 900.43/42
Rating (minutes)	1½	1½	1½	1½	1½	Continuous	Continuous	1½	1½	1½
Brake coil resistance (ohms)	2.2 - 2.6	2.8 - 3.48	2.15 - 2.65	0.903 - 1.0	2.15 - 2.65	465 - 535 4.464 - 5.136	81.84 - 94.16 .85 - 1.15	2.8 - 3.5 12.25 - 14.7	2.8 - 3.5 12.25 - 14.7	0.93 - 1.07 85.56 - 98.44
Field coil resistance (ohms)	2.55 - 2.95	7.54 - 8.24	2.6 - 3.0	1.85 - 2.06	2.6 - 3.0	4.68 - 5.72	1.86 - 2.26	7.45 - 8.25	7.45 - 8.25	1.86 - 2.26
Amature across diametrically opposed segments (ohms)	1.0 - 1.2	1.86 - 2.15	0.97 - 1.25	0.85 - 0.95	0.97 - 1.25	2.2 - 2.6 (Across adjacent segments)	0.801 - 0.909 (Across adjacent segments)	1.86 - 2.15	1.86 - 2.15	0.81 - 0.99 (Across adjacent segments)

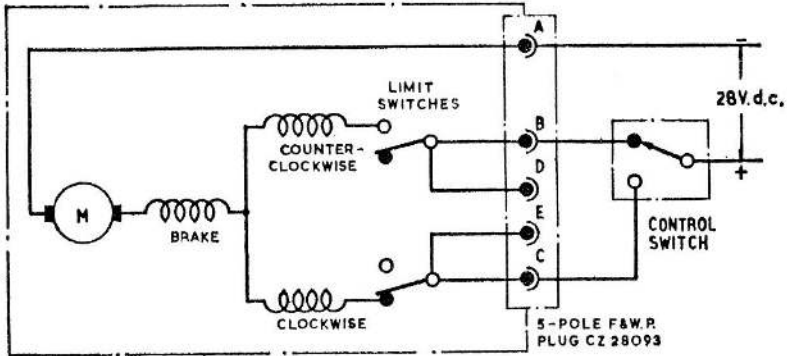

A

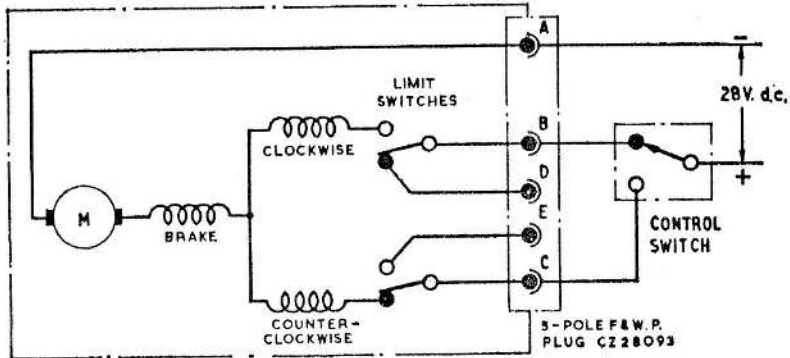

B

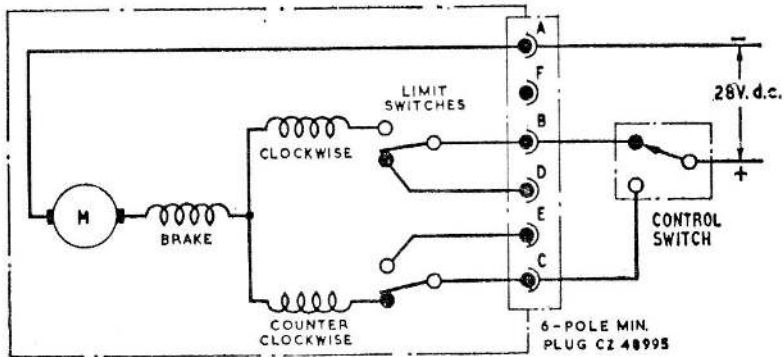

C

Fig. 1. Circuit diagrams A, B, and C

RESTRICTED

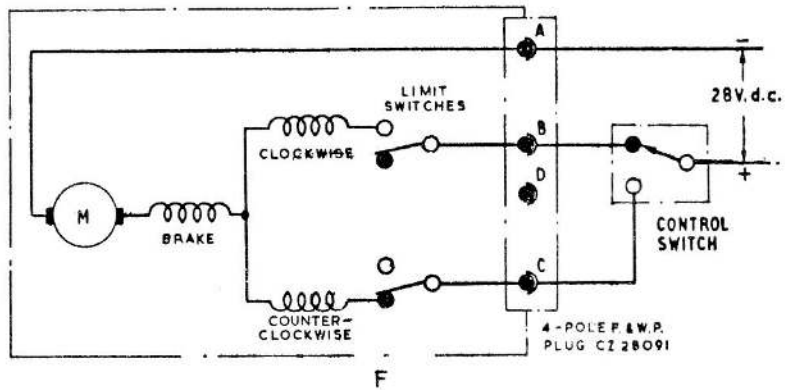
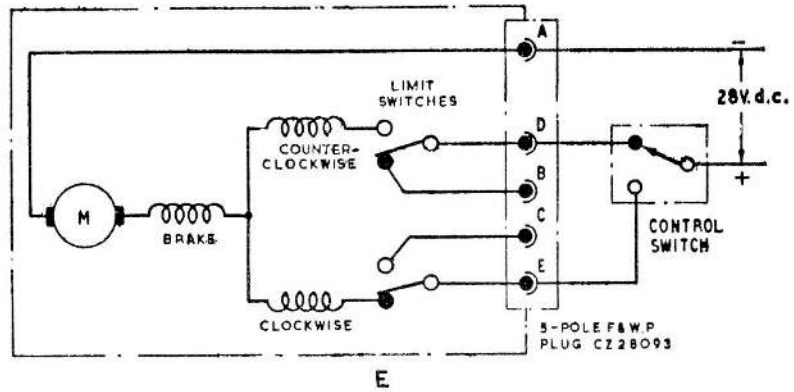
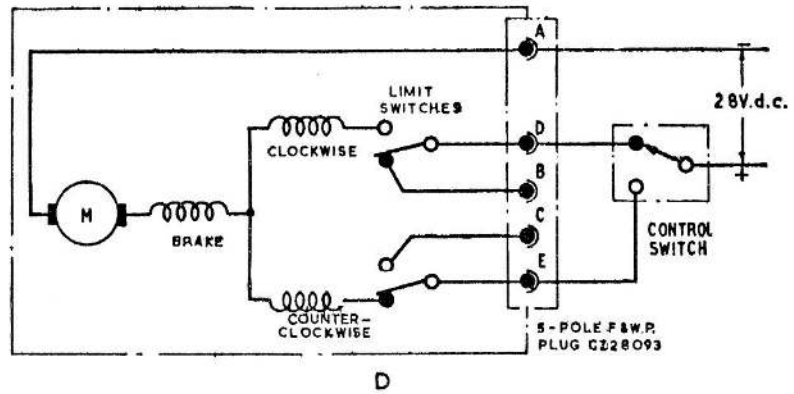

Fig. 1. Circuit Diagrams D, E and F

RESTRICTED

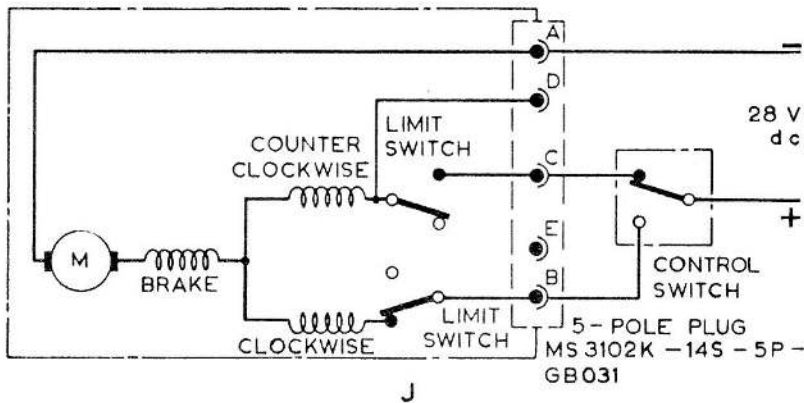
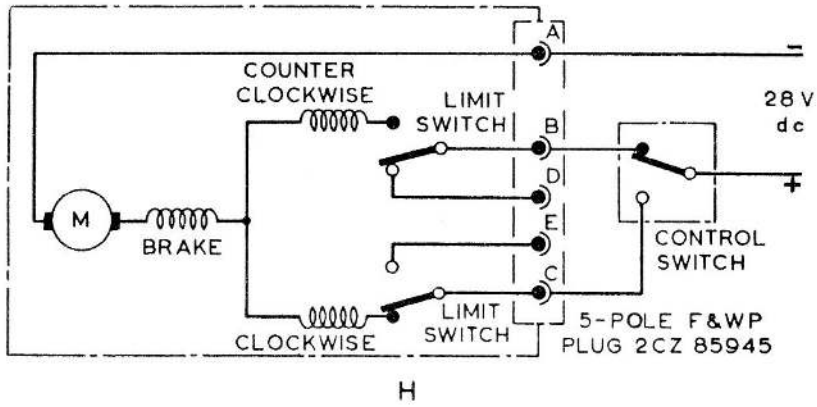
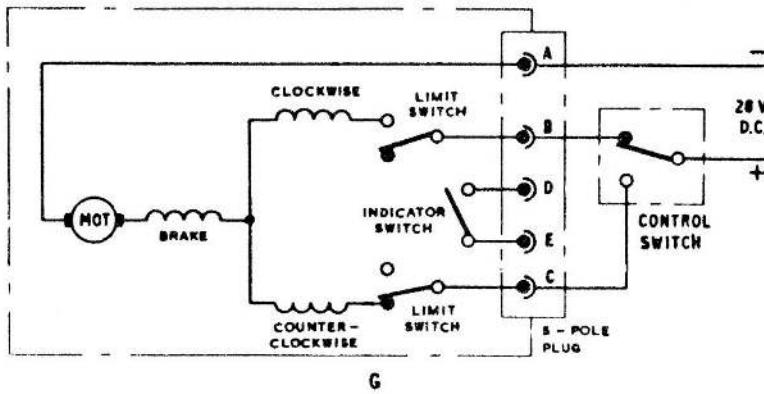
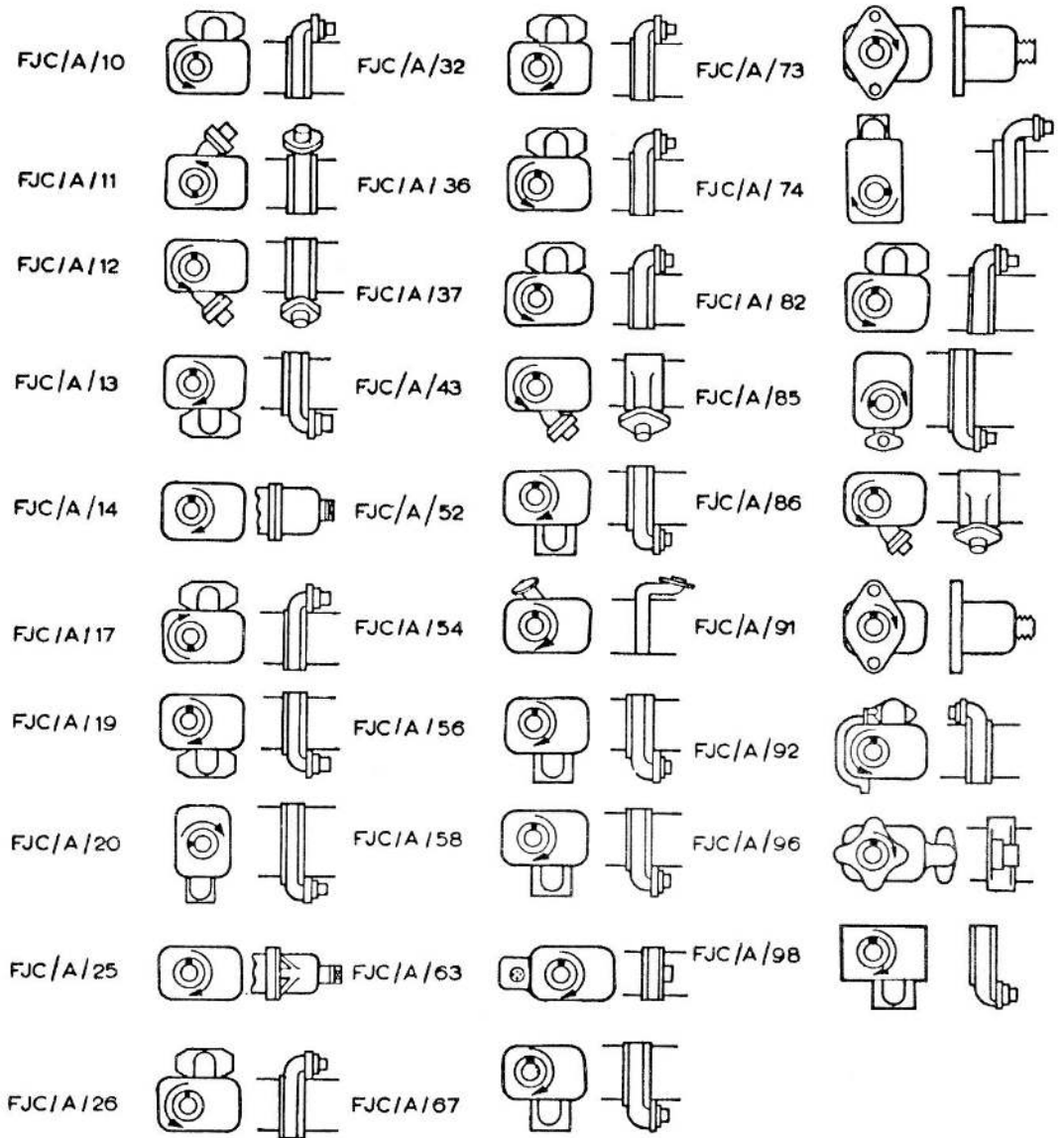

Fig. 1. Circuit Diagrams G,H and J

RESTRICTED



NOTE

THE ARROW SHOWN THUS
INDICATES DIRECTION OF
ROTATION TO OPEN VALVE

MASTER SPLINE ON
SHAFT DENOTED THUS



Fig. 2. Diagram showing relative position of plug and master spline

RESTRICTED

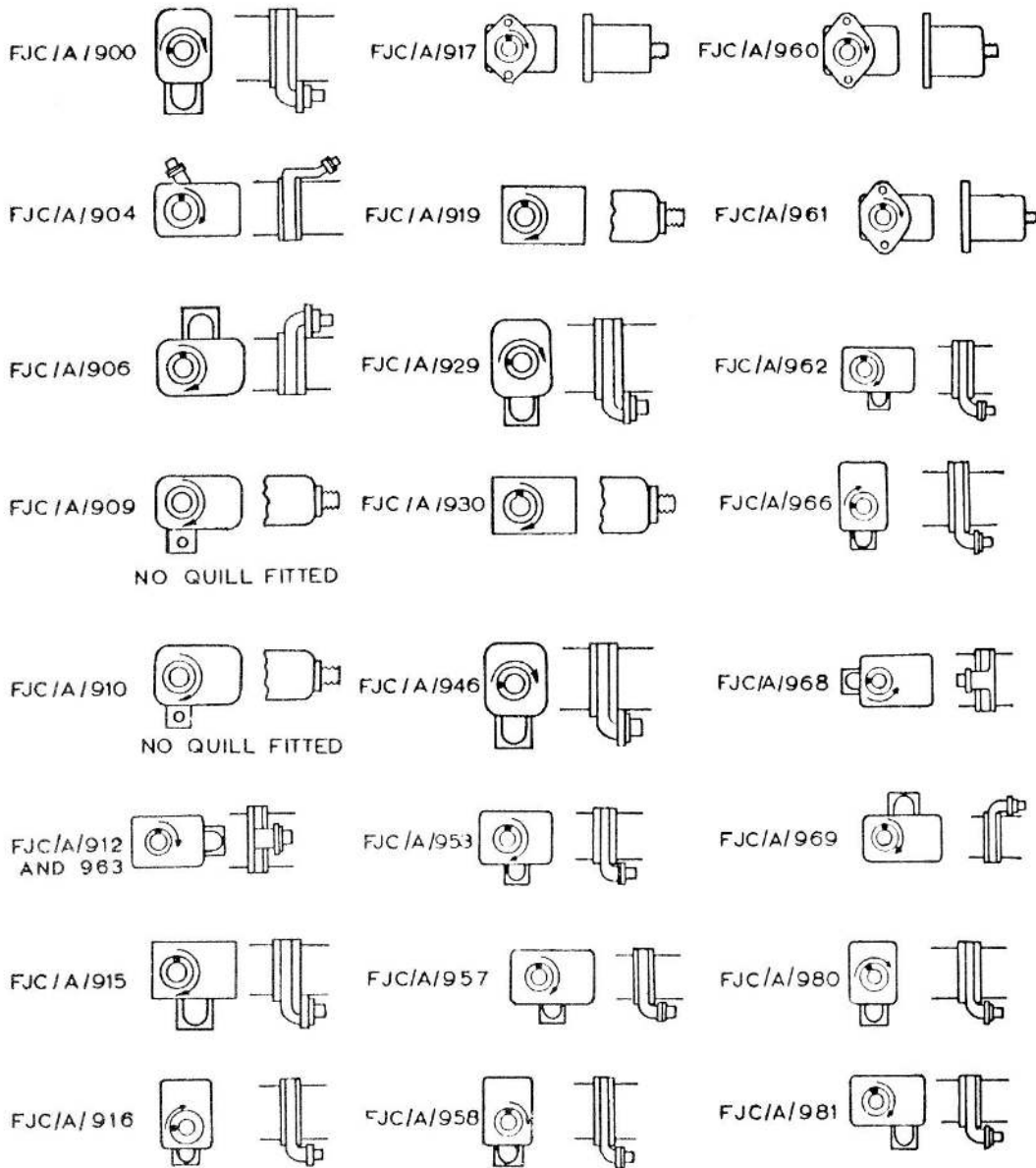

NOTE THE ARROW SHOWN THUS)
INDICATES DIRECTION OF
ROTATION TO OPEN VALVE

MASTER SPLINE ON
SHAFT DENOTED THUS



Fig. 2. Diagram showing relative position of plug and master spline (cont'd)

RESTRICTED

Appendix A (NAVAL)

STANDARD SERVICEABILITY TESTS
for
ACTUATORS, TEDDINGTON FJC/A SERIES
(SINGLE SPEED)**Introduction**

1. The tests detailed in this Appendix are to be applied to an actuator before its installation in an aircraft, at any time when the serviceability of the actuator is in doubt, and at the appropriate re-examination periods at Second Line.

Test equipment

2. The following test equipment is required:-

- (1) Power Supply Unit 5G/3637 or 6130-99-101-8342.
- (2) Single pole changeover switch (as available).
- (3) Insulation Resistance Tester, Type C (5G/152).
- (4) Avometer, Model 8 (Ref. No. 6625-99-943-1524).
- (5) Stop Watch (6B/910-1001).
- (6) Tension Gauge 1H/59).

Test conditions

3. All tests are to be applied at normal room temperature.

Procedure

4. (1) Connect the actuator to the variable supply set to 28V, connected as in Fig. 1 of Appendix 1 to the main

chapter, for the appropriate type of actuator.

(2) Run the actuator over its full range of travel in both directions observing that the rotary arc of travel in degrees in both directions is within the limits laid down in Table 1 of Appendix 1 to the main chapter.

(3) Using the Avometer set to the OHMS scale, check the operation of the limit switch auxiliary contacts, or indicator micro switch as applicable, by running the actuator to its limits in both directions.

(4) Check brush length and brush spring pressure, with reference to Table 3 of Appendix 1 to the main chapter.

Minimum operating voltage

5. Reduce the d.c. supply to the value laid down in Table 1 of Appendix 1 to the main chapter and observe that the actuator operates smoothly in both directions of rotation.

Insulation resistance

6. The insulation resistance between each pin of the electrical plug and the actuator body shall be not less than 500,000 ohms at 250V d.c. The test voltage shall be applied for at least 15 seconds.

RESTRICTED

Appendix A (R.A.F.)

STANDARD SERVICEABILITY TESTS
for
ACTUATORS, TEDDINGTON, FJC/A SERIES
(SINGLE SPEED)**Introduction**

1. The tests detailed in this Appendix are to be applied to an actuator before its installation in an aircraft, at any time when the serviceability of the actuator is in doubt and at the appropriate re-examination periods.

Test equipment

2. The following test equipment is required:-

- (1) Rotary actuator test rig (Ref. No. 4G/6591).
- (2) Insulation resistance tester, Type C (Ref. No. 5G/152).

Test conditions

3. All tests are to be applied at normal room temperature.

Procedure

4. (1) Mount the actuator to the rotary actuator test rig as detailed in A.P. 4343S, Vol.1, Book.2, Sect.8, Chap.7.
- (2) Set the actuator supply to 28V and run the actuator to the conditions specified in App. 1, Table 1.

Minimum operating voltage

5. Set the actuator supply to the minimum operating voltage specified in App. 1, Table 1 and also the applied torque to the value specified in App. 1, Table 1. Under these conditions the actuator must operate over its range in both directions of rotation, but not necessarily to the times laid down.

Insulation resistance

6. The resistance between the pins of the electrical plug and the actuator body must not be less than 0.05 megohm at 250V d.c. The test voltage must be applied for at least 15 seconds.

RESTRICTED

This file was downloaded
from the RTFM Library.
Link: www.scottbouch.com/rtfm
Please see site for usage terms,
and more aircraft documents.

