

## Chapter 50

### CORRECTOR UNIT, ROTOL, TYPE SNC/5

#### LIST OF CONTENTS

	Para.		Para.
Introduction .....	1	Bearing plate .....	9
Description .....	3	Gearbox .....	10
Casing .....	4	Installation .....	20
Stators .....	6	Servicing .....	22
Rotor .....	7	Testing .....	23
Bearings .....	8		

#### LIST OF ILLUSTRATIONS

	Fig.		Fig.
Corrector unit, Type SNC/5 .....	1	Circuit diagram .....	2

#### LEADING PARTICULARS

<b>Corrector unit, Type SNC/5</b>	
Voltage .....	30 V a.c. (nominal)
Frequency .....	90 to 105 C/S
<b>Windings</b>	
Stators .....	3-phase, star
Rotor .....	Squirrel cage
Weight .....	14 lb. 5 oz.

#### Introduction

1. The corrector unit, Type SNC/5, when used in conjunction with the generator, Type SNA/4 (see A.P.4343A, Vol. 1, Sect. 1, Chap. 2) and the control panel, Type SNP/3 (see A.P.4343C, Vol. 1, Sect. 10, Chap. 4) helps to provide engine speed synchronizing on multi-engined aircraft. The corrector unit is supplied from the generator at 29.5 to 34 V, a.c. and a frequency of 90 to 105 C/S.

2. The twin rotor unit of the motor operates a valve, which, when extra r.p.m. is required supplies excess fuel to its associated engine. Each unit is incorporated in a by-pass fuel line independent of the main fuel throttle.

#### DESCRIPTION

3. A part sectioned view of the corrector unit is shown in fig. 1. Two stators and squirrel cage rotor are housed in a casing, whilst the gears, a plunger throttle valve

and a rack sleeve are housed in a gearbox, on which is mounted a Breeze plug. A bearing plate interposed between the motor unit and the gearbox completes the assembly.

#### Casing

4. The casing is machined from a light alloy casting. Four fixing holes are drilled in an integral structure on the side of the casing which forms the mounting face of the corrector unit. Six holes, four attachment and two dowelling, are drilled in the flanged head of the casing, to which the bearing plate and gearbox are secured.

5. A step in the casing bore near the outer bearing forms an abutment face against which the bottom stator rests. Both stators are separated by a split separator ring and finally held longitudinally by a retaining ring screwing into the casing. Radially they are located by rivets pro-

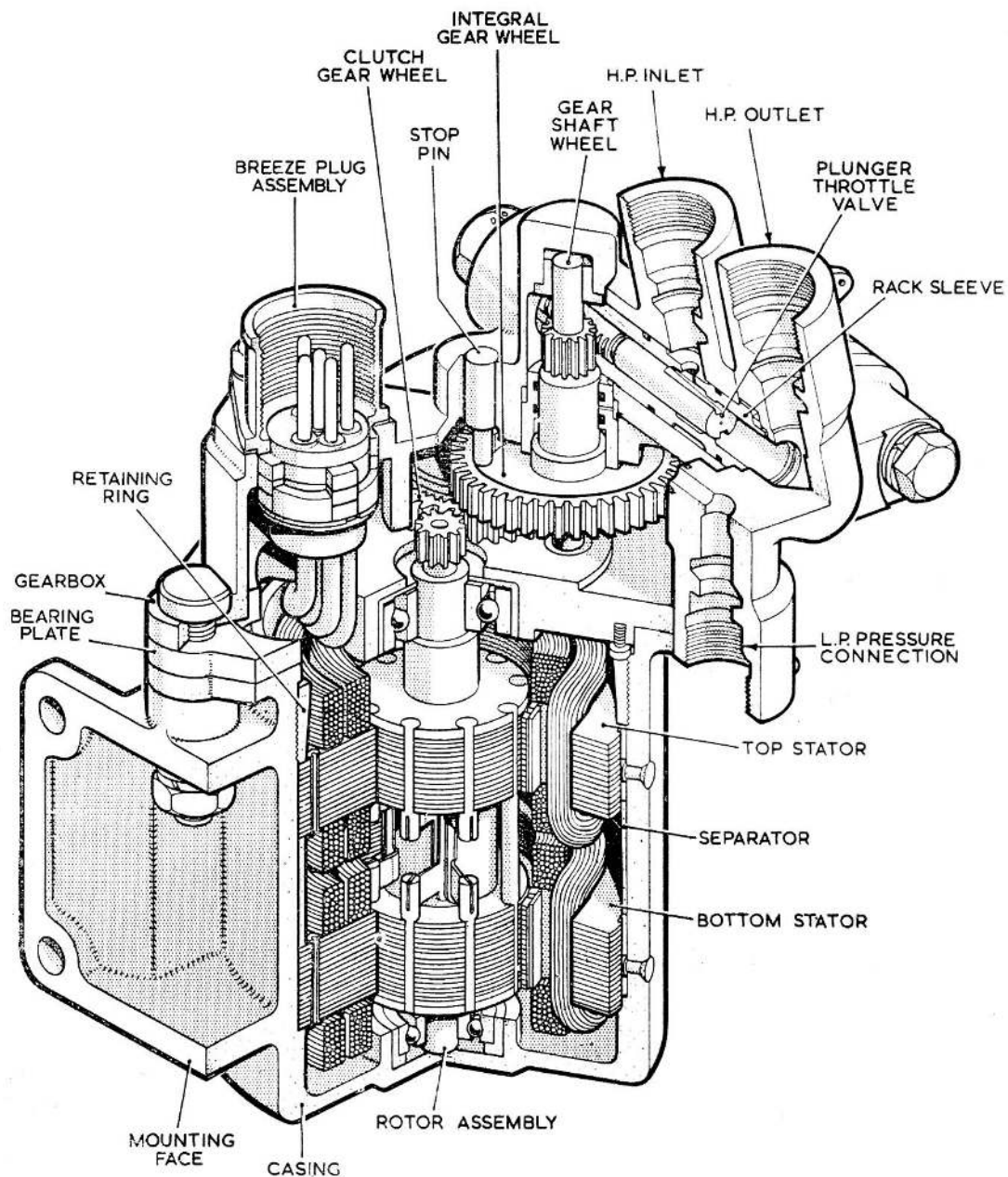

Fig. 1. Corrector unit, Type SNC/5

jecting into slots machined in the laminations.

#### Stators

6. Both stators are three phase, star connected and of similar construction. They are built up with steel laminations riveted together with tubular rivets. The rivets of the top stator (i.e. The one nearest the

gearbox) have specially enlarged bores and the leads from the windings of the bottom stator pass through them.

#### Rotor

7. The squirrel cage rotor comprises two laminated steel stacks separated by a tube and mounted on a shaft. On the outer end of each stack is a copper shorting ring.

**RESTRICTED**

These rings are interconnected by copper conductor rods passing through slots in the stacks and copper connecting strips. As may be seen in fig. 1 two diametrically opposite conductors are of sufficient length to pass directly from one shorting ring to the other. The remaining short conductors protrude from the inner ends of the stacks where they are interconnected, a conductor of one stack to a conductor of the other stack, by the connector strips.

#### **Bearings**

**8.** The rotor shaft runs in two, single row, caged, ball bearings. The gearbox and bearing is the larger and locates against a shoulder on the shaft. The other bearing locates up to a distance piece fitted on the shaft against the bottom of the rotor. The rotor shaft passes through the bearing plate and terminates in an integral pinion.

#### **Bearing plate**

**9.** Two stepped dowels in the bearing plate locates the casing and gearbox. A liner secured in the plate carries the rotor bearing. A laminated shim fitted between the rotor bearing and the liner determines the amount of rotor shaft end float. A 6B.A. screw in the bearing plate locks the stator retaining ring. There are five tapped holes for this screw thus ensuring that it can be fitted in a position where its head will engage one of the four slots in the retaining ring. A cut-away in the bearing plate permits the passage of the stator leads and Breeze plug. This allows the removal of the gearbox and bearing plate without the necessity of disconnecting the leads from the Breeze plug pins.

#### **Gearbox**

**10.** Two gears and a plunger throttle valve operating in a rack sleeve, are housed in the gearbox to which is bolted a two-way (H.P. and L.P.) fuel outlet connector. The H.P. fuel inlet connection is integral with the gearbox. Fitted in the gearbox is a banjo pillar connection for a fuel drain pipe to atmosphere.

**11.** Of the two gear wheels in the gearbox, one is integral with its shaft while the other drives its shaft through a three-plate clutch. The squirrel cage rotor shaft meshes with the clutch gear wheel on the shaft of which is a pinion meshing with the integral gear

wheel. On the shaft of this gear wheel is cut a pinion meshing with the rack teeth of the plunger throttle valve. The rotary motion of the rotor is thus converted into linear movement of the plunger throttle valve.

**12.** The three plate clutch fits in the recessed face of its associated gearwheel and is set to slip between 5 and 7 lb. in. by means of a pronged, dished spring and an adjusting washer of the requisite thickness. The shaft for this assembly runs in plain bushes at either end.

**13.** To limit the travel of the throttle valve, the inner rim of the integral gear wheel is cut-away over an arc of approximately 220 deg. to form two shoulders which abut a stop-pin secured in the gearbox by a taper pin. Sufficient rotation of the gear wheel results in one shoulder or the other, dependent on direction of rotation, abutting the stop-pin and thereby determining the fully open or fully shut position of the plunger throttle valve.

**14.** The internal gear shaft runs in two bushes and bottoms on a locating pad in the bearing plate. Both bushes are fitted in the gearbox and each is locked in position by a peg. The gear shaft passes through the lower bush into an upper chamber of the gearbox connected to the low pressure side of the engine fuel system. To prevent leakage of fuel, two sealing rings are fitted in the grooved bore of the lower bush. An annulus in the gearbox receives any fuel leaking past the periphery of the lower bush, whence it is drained off to atmosphere via a drilling communicating with the banjo pillar connection.

**15.** A lateral drilling in the head of the gearbox houses the rack sleeve in which the plunger throttle valve operates. One end of this drilling is blanked off by a sealing washer and a plug which screws into a steel insert in the gearbox. At the other end of the drilling, the gearbox is machined to form an attachment face for the fuel outlet connector. Fitted in the attachment face are two  $\frac{1}{4}$  in. B.S.F. steel inserts. A drilling from the upper, L.P. fuel chamber of the gearbox breaks through on this attachment face.

16. The plunger throttle valve is a sliding fit in the rack sleeve. The cylindrical metering head of the valve moves through a metering bore line of the sleeve. Cut in the head of the valve are two, diametrically opposite slots at an angle to the axial centre line, thus forming a taper for controlling fuel flow. Machined in the waisted stem of the valve are the rack teeth.

17. Four equally spaced and radially disposed holes are drilled in the rack sleeve for passage of incoming fuel to the metering bore line. These holes align with an annular space in the gearbox, into which the bore of the integral H.P. inlet connection breaks. Three sealing rings are fitted in the suitably grooved periphery of the rack sleeve to prevent fuel leakage.

18. The gear shaft pinion meshes with the plunger throttle valve teeth through a cut-away in the rack sleeve. An integral key on the periphery of the flanged head of the rack sleeve locates the cut-away in its correct position relative to the gear shaft. The rack sleeve is secured in the gearbox by the fuel connector. The mating face of the connector is suitably counterbored and recessed to fit over the keyed head of the sleeve, and to house two sealing rings to isolate the L.P. and H.P. outlet fuel lines.

19. The fuel connector is secured to the gearbox by two  $\frac{1}{4}$  B.S.F. set bolts, with washers. Holes are drilled in suitable places of the gearbox and fuel connector for utilizing when wire locking the four fuel pipes connected to the corrector unit.

#### INSTALLATION

20. The circuit diagram of the corrector unit is given in fig. 2. Before installing, check that :—

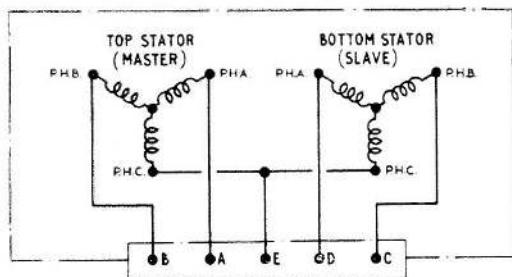

Fig. 2. Circuit diagram

- (a) The type number of the unit is correct for the installation.
- (b) All blanking plates, plugs and caps are removed from the corrector unit and the engine fuel pipes.
- (c) The threads of the Breeze plug and the harness socket are serviceable, and that the pins of the plug are clean and undamaged.
- (d) The threads of all fuel connections of the corrector unit and engine pipes are serviceable.
- (e) The correct serviceable glands are fitted in the grooves of the corrector unit fuel connections.
- (f) The mounting faces of the corrector unit and the engine are clean and free from burrs.

21. The corrector unit can now be installed as follows :—

- (a) Locate the corrector unit on the engine in the correct position and firmly secure.
- (b) Connect the harness socket to the corrector unit Breeze plug and wire lock.
- (c) Fit the fuel drain pipe banjo to the banjo pillar, one washer on each side of the banjo. Screw on the cap nut, tighten and wire lock.
- (d) Fit the high pressure inlet and outlet, and the low pressure outlet fuel pipes to their associate connections on the corrector unit. Care must be taken whilst fitting the pipes to avoid damaging the glands in the corrector unit.
- (e) Wire lock the fuel pipes.

#### SERVICING

22. While the corrector unit is still on the aircraft it should be checked to make sure it is secure, that there are no leaks from the fuel pipe connectors, and that the electrical connections are secure and free from corrosion. If the unit is removed from the engine the checks detailed in para. 20 should also be carried out.

#### TESTING

23. An insulation test should be applied using a 250 V. insulation tester. The insulation resistance from any plug pin to earth should be not less than 0.05 megohms.

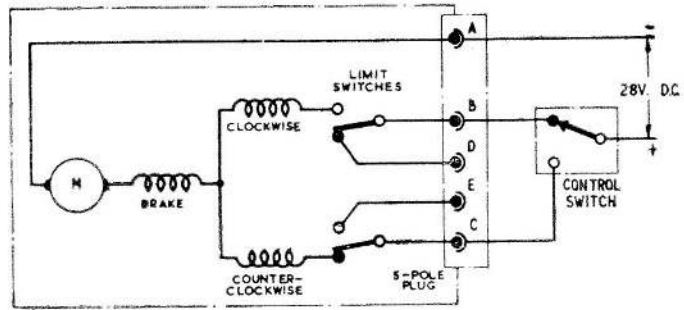

Fig. 3, Circuit diagram

This file was downloaded  
from the RTFM Library.

Link: [www.scottbouch.com/rtfm](http://www.scottbouch.com/rtfm)

Please see site for usage terms,  
and more aircraft documents.

