

## Chapter 53

### ACTUATOR, ROTAX, TYPE C9101

#### LIST OF CONTENTS

	Para.		Para
Introduction	1	Overload clutch	11
Description	2	Output shaft	12
Main motor	4	Operation	13
Main brake	5	Installation	17
Main overrun clutch	6	Servicing	20
Main gearbox	7	Brushes, main motor	21
Emergency motor	8	Brushes, emergency motor	22
Emergency brake and overrun clutch	9	Insulation resistance test	24
Emergency gearbox	10		

#### LIST OF ILLUSTRATIONS

	Fig.		Fig.
Type C9101 actuator	1	Diagram of internal connections	2

#### LEADING PARTICULARS

<b>Actuator, Type C9101</b>	Stores Ref. 5W/361
Voltage	28-V d.c.
Normal load	42.5 lb. ft.
Maximum working load	90 lb. ft.
Current required on normal load :	
Main motor	100 amperes
Emergency motor	35 amperes
Speed of rotation of output shaft (normal load) :	
Main motor driving	250 r.p.m.
Emergency motor driving	60 r.p.m.
Rating	90 seconds
Setting of overload clutch	110 lb. ft.
Reduction ratio of gearbox :—	
Main	30.4 : 1
Emergency	136 : 1
Operational temperature range	—60 deg. C. to + 90 deg. C.
Brush grade	
Main	C.M.6
Emergency	EGO. HAM.
Brush spring pressure :	
Main	41-45 oz.
Emergency	10½-13½ oz.
Minimum brush length :	
Main	.437 in.
Emergency	.406 in.
Length	17.031 in.
Width	8.406 in.
Height	8.650 in.
Weight	36 lb.

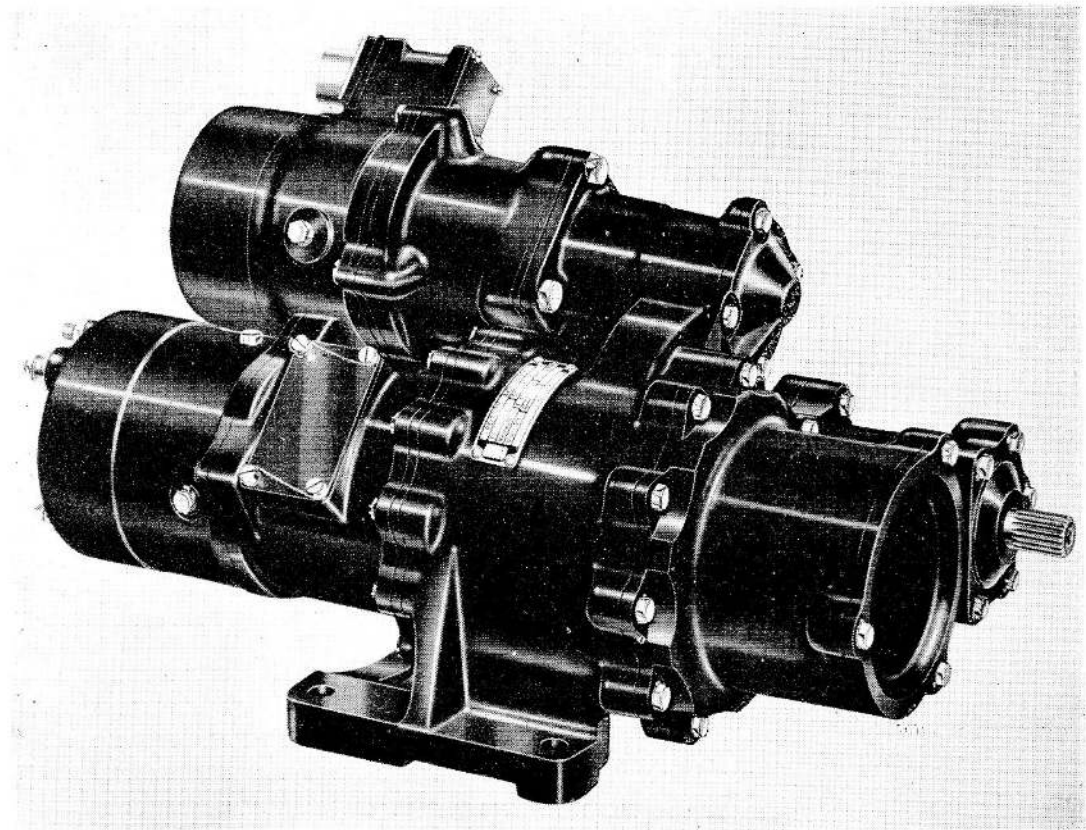

Fig. 1. Type C9101 actuator

#### Introduction

1. Type C9101 actuator is a rotary machine designed to operate ancillary equipment from a 28-V d.c. supply. The rotation of the output shaft is reversible and the actuator may be run continuously for up to 90 seconds. In addition to the main driving motor, an emergency motor is provided, with separate electrical connections, which can operate the equipment (at slower speed) in the event of the main motor, or its supply, failing. The actuator mechanism is protected by an overload clutch set to slip at 110 lb. ft. torque on the output shaft.

#### DESCRIPTION

2. The main motor, main gearbox and overload clutch are assembled in line and are enclosed by cylindrical housings, forming the major part of the actuator. The output shaft is offset horizontally to the right of the overload clutch (looking on drive end). The emergency motor and gearbox are also offset, their common axis being vertically

above the output shaft axis and 45 deg. from the main motor centre vertical.

3. The main motor and brake are enclosed by a motor housing and an intermediate housing, whilst the overrun clutch and brake drum bearing (*para. 6 and 7*) are contained in a bearing housing which closes the drive-end of the motor. The emergency motor, brake and overrun clutch are completely enclosed within a motor housing and an intermediate housing. Both motors are bolted to a common gearbox housing, which is integral with the mounting pedestal. A common housing is bolted to the end of the gearbox housing, containing the overload clutch (coaxial with the main motor) and the offset output shaft.

#### Main motor

4. The main motor is a four-pole compound wound machine. The armature runs in two ball bearings, one set in the commutator end of the motor housing, and the other carried by a liner in the intermediate

RESTRICTED

housing. The brushgear is bolted to the commutator end of the motor housing and the four brushes are maintained in contact with the commutator by helical springs in compression, held in position by spring retainers which locate in the brush inspection windows. The windows are enclosed by a coverband. Electrical connections are made to the motor by five terminal studs set in the end of the motor housing.

#### Main brake

5. The main brake consists of a solenoid coil connected in series with the motor armature) wound on a steel core or "spider" around which rotates a brake drum, driven at armature speed via an overrun clutch (*para. 6*). Six lined brake shoes are located by guide pins around the periphery of the brake spider. They are normally maintained in contact with the interior of the brake drum by helical springs in compression, preventing the drum and, therefore the motor armature and the gear train from rotating. When, however, the brake solenoid coil is energized by supply being connected to the motor, the shoes are drawn in against the compression of the brake springs, leaving the drum free to rotate. The brake is again applied immediately supply is disconnected.

#### Main overrun clutch

6. The main overrun clutch, consisting of a pack of six outer and six inner plates, is located in an internally splined recess in the closed end of the brake drum. The inner member of the clutch is a sleeve with an external spline which engages the inner clutch plates and an internal serrated spline which engages a drive spindle, connecting with the armature shaft via a central bore in the brake spider. The clutch pack is compressed by a helical spring which bears on the inner clutch sleeve. Adjustment of the clutch spring pressure is achieved by a grub screw at the commutator end of the armature shaft, which connects to the spring by a rod passing through a bore in the armature shaft. The grub screw is enclosed by a commutator end bearing cap.

#### Main gearbox

7. The brake drum is carried by a ball bearing which fits the outer surface of the clutch recess. The closed end of the recess is integral with the first stage sungear of a three-stage epicyclic reduction gearbox.

The third stage annulus gear is "floating", being carried by two ball journal bearings; the annulus is also geared externally to receive the drive from the emergency gearbox (*para. 10*). The reduction ratio of the gearbox is 30.4 : 1, armature to output shaft.

#### Emergency motor

8. The emergency motor is a four-pole, compound wound machine. The commutator end of the armature is supported by a ball bearing set in the closed end of the emergency motor housing, whilst the drive-end of the armature shaft is supported by the clutch pack within the brake drum ball bearing (*para. 9 and 10*). The brushgear is secured to the commutator end of the motor housing and the four brushes are maintained in contact with the commutator by coiled brush springs. Windows are provided for the inspection of the brushes and these are enclosed by a coverband. Electrical connections are made to the emergency motor via a five-pole plug.

#### Emergency brake and overrun clutch

9. The emergency brake and overrun clutch, although smaller in dimensions, are generally similar to the main brake and clutch (*para. 5 and 6*). There are, however, only four brake shoes operated by the solenoid. There is a solid connection between the armature and the inner clutch sleeve, there being no external adjustment of the clutch spring pressure.

#### Emergency gearbox

10. The emergency brake drum is carried by a ball bearing contained in the end of the intermediate housing and is integral with the first stage sungear of the three-stage epicyclic emergency gearbox. The output of this gearbox is transmitted via an idler gear to the outer gear of the main gearbox floating annulus and thence through the last stage planet carrier of the main gearbox to the output shaft. The reduction gear ratio from the emergency motor armature to the output shaft is 136 : 1.

#### Overload clutch

11. The third stage planet carrier of the main gearbox is integral with a shaft which engages in the inner member of a multiplate overload clutch. The drive is transmitted to the outer clutch barrel by a pack of ten steel inner plates and eleven outer plates

of steel coated with sintered bronze. This pack is under pressure from a ring of sixteen helical springs compressed by a nut which screws into the barrel. The clutch is set to slip at 110 lb. ft. torque (applied to the output shaft).

#### Output shaft

12. The clutch barrel is integral with a sleeve which surrounds the planet carrier shaft and runs in two ball bearings between which it carries a driving gear. This gear drives a gear which forms the inner end of the output shaft, which also runs in two ball bearings. The shaft terminates in a serrated spline. The cap which seals the end of the output shaft housing contains a felt oil seal to prevent the ingress of oil into the housing along the shaft.

#### Operation

13. The connections to the main motor are as follows:—

- (a) To obtain clockwise rotation of the output shaft (looking on drive end)
  - Terminal 1 negative.
  - Terminals 2 and 5 positive.
  - Terminals 3 and 4 interconnected.
- (b) To obtain anti-clockwise rotation of the output shaft (looking on drive end).
  - Terminal 1 negative.
  - Terminals 3 and 5 positive.
  - Terminals 2 and 4 interconnected.

14. The connections to the emergency motor plug (*para.* 18) are:—

- (a) To obtain clockwise rotation of the output shaft (looking on drive end).
  - Pole 1 negative.
  - Poles 2 and 5 positive.
  - Poles 3 and 4 interconnected.
- (b) To obtain anti-clockwise rotation of the output shaft (looking on drive end).
  - Pole 1 negative.
  - Poles 3 and 5 positive.
  - Poles 2 and 4 interconnected.

15. When supply is connected to either motor, its brake coil is energized and the brake shoes are pulled away from the inner surface of the brake drum so that the armature and the gear train are free to rotate. The motor drives the load in the appropriate direction of rotation until the end of travel is reached, when supply to the motor will be disconnected by external switching. The

brake coil is then de-energized, and the brake shoes will arrest the brake drum and, therefore, the gear train and output shaft while the momentum of the armature is absorbed by the slipping of the overrun clutch. In this way overrun of the output shaft is reduced to a minimum.

16. When the main motor is driving, the floating annulus of the main gearbox (*para.* 7 and 10) is locked by the emergency brake through the emergency gearbox, so that the main gearbox operates as a normal three-stage epicyclic train. When the emergency motor is driving, torque is transmitted through its three-stage gearbox to the floating annulus of the main gearbox. The annulus then rotates, driving the third stage planet carrier around its sun gear which is now locked by the main brake.

#### INSTALLATION

17. A pedestal, integral with the gearbox housing is provided for mounting the actuator. The mounting feet have four 0.385 in. diameter clearance holes whose fixing centres form a rectangle 5.500 in. by 4.000 in..

18. Terminals 1 and 4 of the main motor are  $\frac{5}{16}$  in. B.S.F. studs whilst terminals 2 and 3 are  $\frac{1}{4}$  in. B.S.F. studs and terminal 5 is a 3 B.A. stud. Electrical connections to the emergency motor are made via a Breeze plug (*para.* 14) (Stores Ref. 5X 6061).

19. The output shaft has a nominal diameter of 0.625 in. with a spline consisting of 20 serrations. The full depth of the serrations extends for 0.625 in. along the shaft.

#### SERVICING

20. Make a general inspection of the actuator to ensure that it is in good condition and has not sustained damage. Check that the unit is secure on its mounting, that the output shaft is adequately coupled to the load equipment and that electrical connections are sound and clean.

#### Brushes, main motor

21. Remove the coverband of the main motor and release the four brush springs by pushing and turning the spring retainers so that they can be withdrawn from the windows. Make the following inspections:—

- (a) Ensure that the brushes are in good condition and are not cracked or chipped

in any way; ensure that the flexible connections are secure.

- (b) Measure the length of the brushes. The minimum permissible brush length is 0.437 in. and any brush which is close to this minimum and which is unlikely to last until the next servicing should be regarded as unserviceable.
- (c) Ensure that the brushes slide easily in their boxes but are not slack. If tightness is due to carbon deposit on the interior surfaces of the boxes, the deposit should be removed.
- (d) Examine the commutator for burns and scores. Carbon deposit should be removed where possible.
- (e) Check the brush springs. The free length of the springs should be 0.781 in. to 0.843 in. The pressure required to compress them to their working length of 0.437 in. should be 41 to 45 oz. This should be measured with a spring balance (Stores Ref. 1H/97).

#### Brushes, emergency motor

**22.** Remove the coverband from the emergency motor and make the following inspections.

- (a) Examine the brushes and ensure that they are not cracked or chipped in any way and that the flexible connections are secure.
- (b) Measure the length of the brushes. The minimum permissible brush length is 0.406 in. and any brush which has

worn close to minimum length and which may not last until the next servicing should be regarded as unserviceable.

- (c) Ensure that the brushes are free but not slack in their boxes. If tightness is due to carbon deposit on the interior surfaces of the boxes, the deposit should be removed.
- (d) Examine the commutator for scores and burns. Carbon deposits should be removed where possible.
- (e) The brush spring pressure should be  $10\frac{1}{2}$  to  $13\frac{1}{2}$  oz. (308 to 383 gm.). This should be measured with a tension gauge (Stores Ref. 1H/86) at the point where the brush spring leaves the top of its brush.

**23.** Any actuator which is found to be defective in any respect should be regarded as unserviceable, removed from service, and a unit of known serviceability installed in its place. If the actuator is serviceable, ensure that all brushes and brush springs are properly in place and refit the coverbands. Ensure that all locking tabs and tie-wires are secure.

#### Insulation resistance test

**24.** Finally, measure the insulation resistance between all live parts and frame, using a 250-V insulation resistance tester. The insulation resistance should in no instance be less than 50,000 ohm.

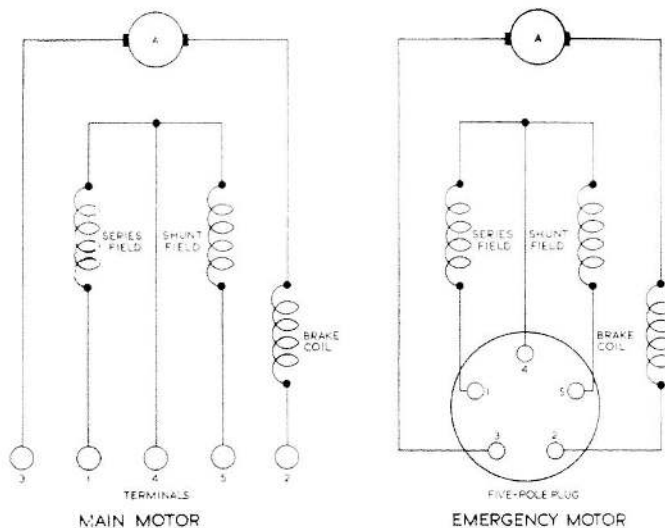

**Fig. 2.** Diagram of internal connections

#### Note . . .

*The value of insulation resistance given in para. 24 applies to actuators being tested under normal workshop conditions. Due allowance should be made for the climatic conditions of the locality and those of the aircraft servicing area or dispersal point where the tests are being applied. In particularly damp climates, the readings obtained may be low enough to give apparently sufficient reason for rejection and, in these instances, discretion should be exercised.*

This file was downloaded  
from the RTFM Library.

Link: [www.scottbouch.com/rtfm](http://www.scottbouch.com/rtfm)

Please see site for usage terms,  
and more aircraft documents.

