

Chapter 62

ACTUATOR, ROTAX, TYPE C8401

LIST OF CONTENTS

	Para.		Para.
<i>Introduction</i>	1	<i>Operation</i>	8
Description	2	Installation	10
<i>Motor</i>	4	Servicing	13
<i>Brake and clutch</i>	5	<i>Brushes and commutator</i>	14
<i>Gearbox</i>	7	<i>Insulation resistance test</i>	19

LIST OF ILLUSTRATIONS

	Fig.		Fig.
<i>Type C8401 actuator</i>	1	<i>Diagram of internal connections</i>	2

LEADING PARTICULARS

Motor, Type C8401	Ref. No. 5UD/5852
<i>Voltage</i>	28V, d.c.
<i>Current at normal load A/CW rotation</i>	34 amp.
<i>Current at normal load CW rotation</i>	25 amp.
<i>Brush spring pressure</i>	12±1 oz.
<i>Brush grade</i>	EGO.HAM
<i>Minimum brush length</i>	0.312 in.
<i>Normal load A/CW rotation</i>	125 lb. ft. torque
<i>Normal load CW rotation</i>	100 lb. ft. torque
<i>Speed of A/CW rotation at normal load</i>	20 r.p.m.
<i>Speed of CW rotation at normal load</i>	15 r.p.m.
<i>Maximum static load</i>	400 lb. ft. torque
<i>Rotation</i>	Continuous
<i>Rating CW and A/CW</i>	1 minute
<i>Operational temperature range</i>	-75 deg. C. to +90 deg. C.
<i>Gearbox reduction ratio</i>	485 : 1
<i>Length</i>	10.700 in.
<i>Width</i>	5.875 in.
<i>Height</i>	6.062 in.
<i>Weight</i>	14 lb. 4 oz.

Introduction

1. The actuator, Type C8401, consists of a reversible 28V d.c. motor and built-in gearbox. The machine draws 34 amperes when rotating anti-clockwise at its normal load of 125 lb. ft. torque and 25 amperes when rotating clockwise at its normal load of 100 lb. ft. torque.

DESCRIPTION

2. The actuator is of "in-line" construction and consists of a reversible motor

driving an output shaft through an epicyclic reduction gearbox. An electro-magnetic brake and an overrun clutch are also incorporated.

3. The actuator is enclosed by four housings. The motor housing which contains the motor armature, yoke, brush-gear and commutator end ball bearing, carries a five-pole plug for external connection. The intermediate housing contains the armature drive end ball bearing and carries the brake. The gearbox housing and mounting pedestal

RESTRICTED

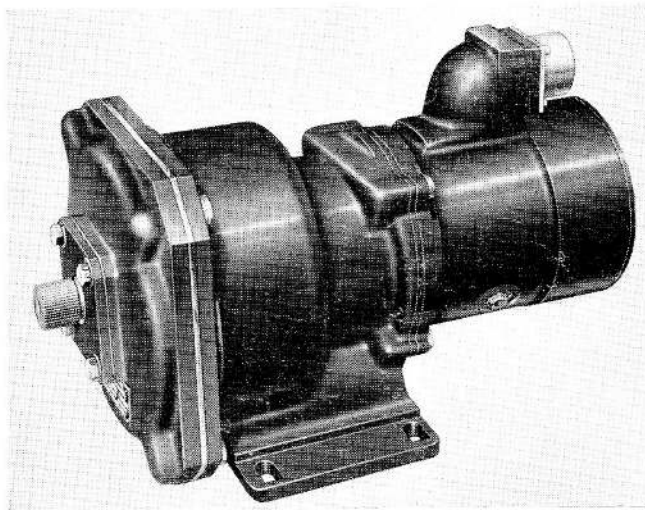

Fig. 1. Type C8401 actuator

contains the epicyclic gear train, brake drum, clutch and clutch drive bearing. The drive end housing contains the final annulus gear, drive shaft and ball bearing. The motor housing, intermediate housing and gearbox housing are held together by four bolts. The gearbox housing and the drive end housing are held together by four bolts. A coverband encloses two window openings in the motor housing to provide access to the brushes.

Motor

3. The motor is a four-pole split field series machine, one half of the field winding being used for each direction of rotation. The armature is carried by a ball bearing at the commutator end and at the drive end. The drive shaft is splined to engage the clutch plates. Four brushes, mounted on a flat Bakelite base, make contact with the commutator, brush pressure being maintained by flat coil springs.

Brake and clutch

5. The brake solenoid is secured to the interior of the intermediate housing. A brake drum, carried by the outer clutch plate housing can rotate about the solenoid,

but is normally held stationary by four brake shoes (located by pins in the brake solenoid core or "spider") which are forced against the interior of the drum by helical springs. The shoes are pulled inwards away from the drum, leaving it free to rotate,

whenever the solenoid is energized. The solenoid is in series with the motor armature.

6. The armature shaft passes through a bore in the centre of the brake solenoid core and engages the splined clutch plate carrier which is forced against the mating clutch plates by a helical spring about the armature shaft. The mating clutch plates are carried by the splined outer clutch plate housing which is also the first sun gear in the epicyclic train. The outer clutch plate housing and brake drum are carried by a ball bearing. When the brake drum is arrested, as a result of the actuator supply being switched off, the clutch slips to dissipate armature momentum. In this way overrun of the output shaft is reduced to a minimum.

Gearbox

7. The first stage sun gear of the four-stage epicyclic gearbox is part of the outer clutch plate housing. The final stage planet carrier is part of the output shaft and is carried in a ball bearing. The four sets of planet gears run within a single annulus gear which is secured by a flange between the gearbox housing and the drive end housing. The reduction ratio of the gearbox is 485 : 1.

Operation

8. Pole "1" of the five-pole plug is the negative line; pole "2" is positive for clockwise rotation and pole "3" is positive

RESTRICTED

for anti-clockwise rotation. Poles "4" and "5" are not connected.

9. When positive supply is connected to the required pole of the plug, the appropriate motor field is energized and the brake solenoid is energized via the armature. The brake shoes are withdrawn from the brake drum and the motor rotates the output shaft until the supply is broken and the output shaft is arrested by the brake shoes which are released on to the brake drum. The clutch allows the motor to rotate after the supply is broken until the armature momentum is dissipated.

INSTALLATION

10. Four slots 0.328 in. wide with radiused ends on centres 0.312 in. apart are provided in the mounting pedestal, which is 0.281 in. thick. The slots are spaced on the centres of inner radii 4.625 in. by 2.750 in.

11. The output shaft has a nominal diameter of 0.750 in. into which are cut 48 fine serrations to B.S. Specification A.19. The length of the serrated spline is 0.593 in. from the end of the shaft.

12. Electrical connection is made by a five-pole breeze plug (Ref. CZ/50359).

SERVICING

13. Make a general inspection of the actuator to ensure that it has not sustained damage. Ensure that it is secure on its mounting and that the electrical connection is sound.

Brushes and commutator

14. Remove the coverband from the motor housing and make the following inspections.

15. Remove the brushes and examine them for cracks, security of flexible connections and wear. Ensure that the length of the brush (see Leading Particulars) is of adequate length to give a satisfactory performance until the next servicing.

16. Examine the commutator for scores and burns. If its condition is such that commutation is likely to be impaired, the actuator is to be considered unserviceable.

17. Ensure that the brushes are free but not slack in their boxes. If they are tight as a result of carbon being deposited in the brush boxes, the deposits should be removed.

18. Measure the pressure of each brush spring with a tension gauge (Ref. No. 1H/86). Each spring should exert a pressure of 11–13 oz. (311.9 to 368.6 gm.) when its leaves the top of its brush.

Insulation resistance test

19. Measure the insulation resistance between live parts and frame, using a 250V insulation resistance tester. A reading of at least 50,000 ohm should be obtained.

Note . . .

The value of insulation resistance given in para. 19 applies to actuators being tested under normal workshop conditions. Due allowance should be made for the climatic conditions of the locality and those of the aircraft servicing area or dispersal point where the tests are being applied. In particularly damp climates, the readings obtained may be low enough to give apparently sufficient reason for rejection and, in these instances, discretion should be exercised.

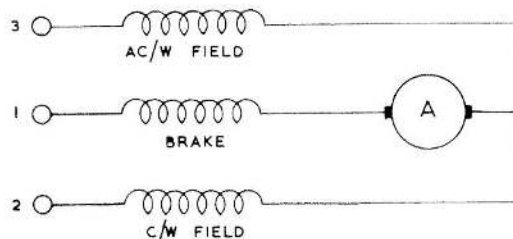

Fig. 2. Diagram of internal connections

This file was downloaded
from the RTFM Library.

Link: www.scottbouch.com/rtfm

Please see site for usage terms,
and more aircraft documents.

