

Chapter 71

ACTUATOR, ENGLISH ELECTRIC, TYPE 237, Mk. 2

LIST OF CONTENTS

	<i>Para.</i>		<i>Para.</i>
<i>Introduction</i>	1	<i>Limit switches</i>	20
Description	3	Operation	21
<i>Housing and covers</i>	7	Installation and servicing	27
<i>Motor</i>	12	<i>Insulation resistance test</i>	33
<i>Gearbox and clutch</i>	15		

LIST OF ILLUSTRATIONS

	<i>Fig.</i>		<i>Fig.</i>
<i>General view of actuator</i>	1	<i>Circuit diagram</i>	4
<i>Sectional view of actuator</i>	2	<i>Installation drawing</i>	5
<i>Schematic wiring diagram</i>	3		

LEADING PARTICULARS

<i>Actuator, English Electric, Type 237, Mk. 2</i>	<i>Ref. No. 5W/2398</i>
<i>Voltage range</i>	22—29 volt d.c.
<i>Normal operating voltage</i>	28 volt d.c.
<i>Current consumption at normal load</i> 15 amp.
<i>Normal working load</i>	20 lb. in.
<i>Maximum working load</i>	30 lb. in.
<i>Clutch slip load</i>	65—80 lb. in.
<i>Angular travel</i>	90 degrees
<i>Maximum time of angular travel with normal load applied</i>	0.2 seconds
<i>Gear reduction ratio</i>	168.75 : 1
<i>Temperature range of operation</i>	—60 deg.C. to +90 deg.C.
<i>Weight of actuator</i>	3.2 lb.

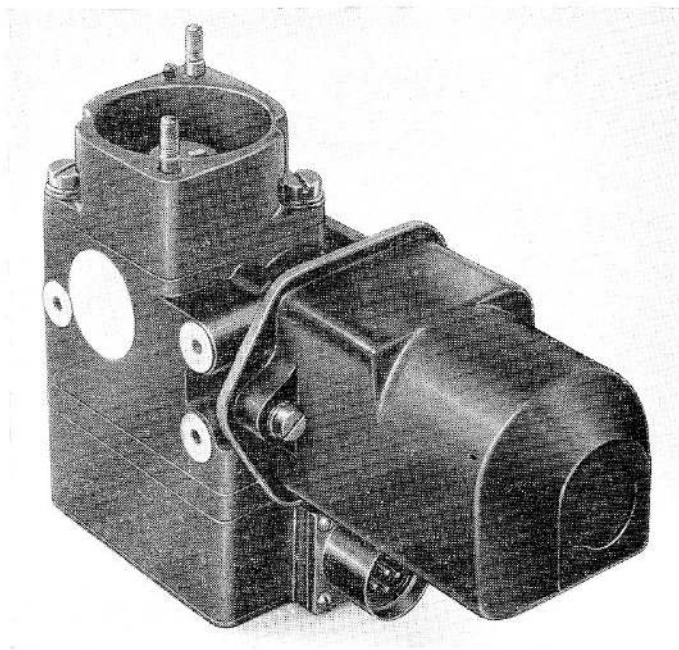

Fig. 1. General view of actuator

Introduction

1. The rotary actuator English Electric Type 237, Mk. 2 (*fig. 1*), has been designed for the operation of fuel cocks, hydraulic valves, etc., used on aircraft.

2. The actuator is capable of handling a normal load of 20 lb. in. and a maximum working load of 30 lb. in. In the event of an accidental overload, the clutch slip load is between 65-80 lb. in.

DESCRIPTION

3. The actuator consists of a 2-pole, split series field, 28 volt d.c. motor, driving through the medium of a double plate friction clutch, a 2-stage epicyclic reduction gear train, and a right angle 4-start worm and wheel. A sectional view of the actuator is shown (*fig. 2*).

4. Snap action limit switches are incorporated to switch off the 28 volt d.c. aircraft supply to the motor at the end of the pre-

determined angle of rotation. Mechanical stops are fitted to prevent overrun of the output shaft of the actuator, thus maintaining constant angular rotation in either direction.

5. A double plate friction clutch is fitted to prevent damage to the motor and gears in the event of overloads, and to dissipate the kinetic energy of the rotating parts when the output shaft comes to rest against the mechanical stops.

6. The actuator is of right-angle construction, the motor, clutch, epicyclic gear train and worm being on the same axis of rotation, whilst the worm wheel, situated on the output shaft, is at right angles to the rotor axis. A moulded Durestos cover over the motor enables the unit to withstand a fireproof test.

Housing and covers

7. The housing comprises three main sections, enclosing motor, gearbox and limit switches respectively.

RESTRICTED

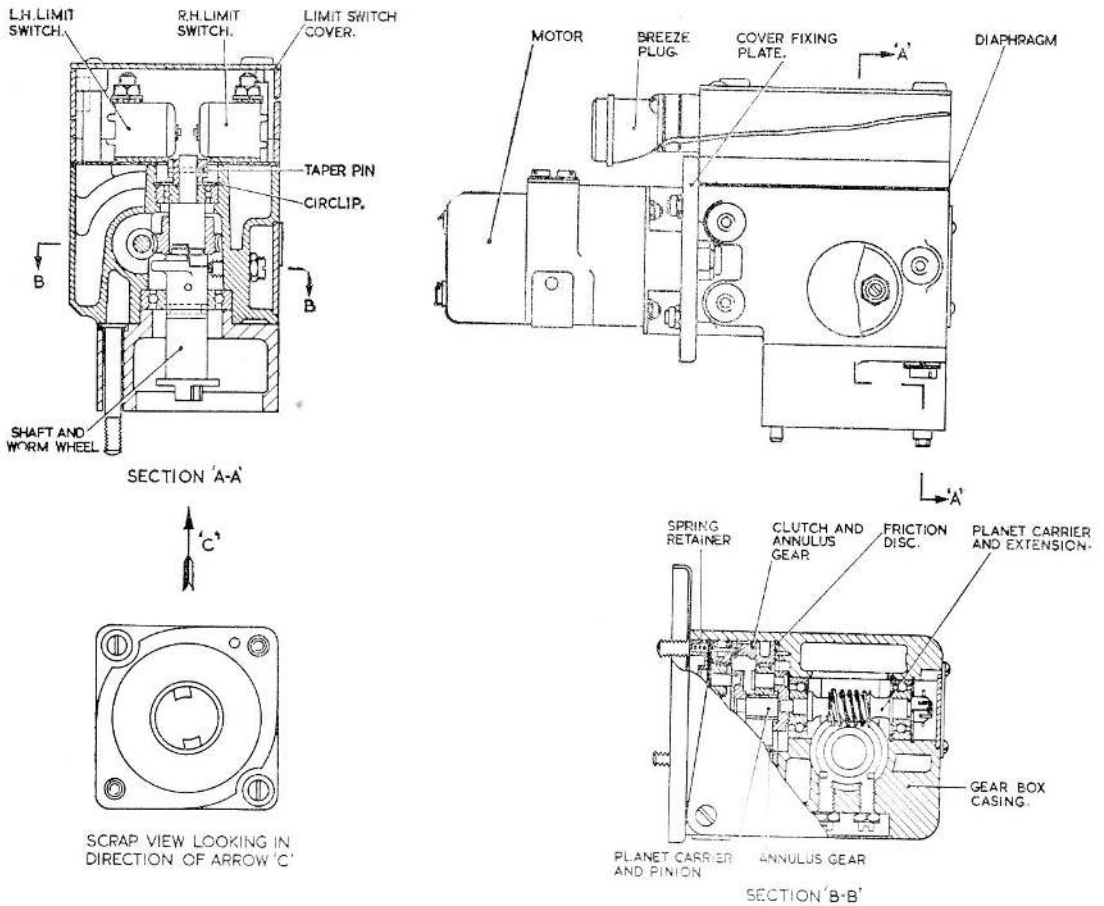

Fig. 2. Sectional view of actuator

8. The motor is a detachable self-contained unit and is housed in three aluminium-alloy, die-castings. The motor frame houses the armature, field coils, brushgear and commutator end bearing, the drive end bearing being housed in the drive end plate; this drive end plate serves to mount the motor on the gearbox, to which it is held by four studs and nuts. The fixing plate for the fireproof cover is trapped between the motor and gearbox housing.

9. The end cover protecting the brushgear and commutator end bearing is held to the motor frame by two small screws and can be withdrawn completely for inspection of the brushgear.

10. The gearbox housing is a die casting of aluminium alloy and contains the epicyclic reduction gear trains, clutch, planet carrier extension shaft and its bearings, the output shaft and its bearings, and the mechanical stops. Steel inserts are fitted on two sides of the housing, into which actuator mounting holes are tapped. Aluminium-alloy discs are pressed into the housing covering the mechanical stops and planet carrier extension shaft bearing locknut, after adjustment of the stops and bearing shim collar.

11. The limit switch housing is an aluminium-alloy, die casting and encloses the limit switch operating arm and limit switches and also locates the "Breeze" connector

plug. Between this housing and the gearbox housing an aluminium alloy diaphragm is fitted to prevent grease from the gears entering the limit switch housing. A rubber grommet is attached to the diaphragm to enable the leads from the motor to pass through to the limit switches and the "Breeze" connector without chafing. Four screws secure the housing, the diaphragm, and aluminium alloy lid to the gearbox housing. These parts are sealed after final adjustments to the limit switches by the manufacturers.

Motor

12. The motor is a 28 volt d.c., 2-pole split series machine. Two field coils in opposition are used, one for either direction of rotation. Connected in series with each field is a limit switch, adjusted to cut off the electrical supply to the motor in either direction of rotation, before the actuator output shaft reaches one of its mechanical stops. The pole-pieces are integral with the yoke; being made up from one set of laminations.

13. The two carbon brushes locate in anodised aluminium brush boxes; the latter are mounted on a moulded brush rocker. Flat coiled springs maintain the required pressure of the brushes on the commutator. The commutator end of the armature shaft is supported by a small phosphor bronze bearing with a felt ring oil reservoir, the drive end of the shaft being supported by a similar bearing in the end plate. The motor leads are located in a wiring duct in the motor frame, passing through the drive end plate.

14. The motor is totally enclosed and flame-proof. A removable end cover allows easy access to the brushgear.

Gearbox and clutch

15. The gearbox is of 2 stage epicyclic and right-angle worm drive construction. The epicyclic gears and the planet carrier extension shaft are in line with the motor axis, the sun gear for the first planet carrier assembly being integral with the motor shaft. The motor drive is thus transmitted to the first epicyclic system. Integral with the first planet carrier assembly is the sun gear for the second planet carrier assembly, which is in turn pressed on to the end of the planet carrier extension shaft and secured by three axial pins. Each planet carrier assembly

comprises three phosphor bronze pinions mounted on flat headed steel pins and riveted into their respective carriers.

16. The second annulus gear works against the friction rings of the clutch; these are held against the annulus by springs, and are designed to slip should the load become excessive. The clutch slip torque may be adjusted by varying the number in the spring retaining ring.

17. The output shaft is supported at right angles to the worm axis by two small ball bearings, one between the worm wheel and output shaft, and the other between the limit switch cam and a shoulder machined on the shaft above the worm wheel.

18. Between the driving end of the shaft bearing and the worm are two stop faces machined on the shaft in the correct angular relation with the driving end, which come into contact with the mechanical stops when the end of the angular travel in either direction of rotation has been reached. The stops are screwed into the gearbox housing at right angles to the output shaft and are sealed in position after final adjustment, by the manufacturers.

19. The limit switch cam is pinned to the shaft also, in the correct relation with the driving end, to allow the limit switches to cut off the electrical supply to the motor, just before the stop faces on the shaft reach the mechanical stops.

Limit switches

20. The limit switches are screwed to clamping plates, which are in turn secured to the gearbox housing by two screws. One of the screw holes in each clamping plate is slotted to provide adjustment for the switches. The switch operating arm is mounted on a pivot so that it is free to move between the two limit switch plungers. The end of the operating arm connects with the limit switch cam; this cam moves the operating arm to depress one switch plunger for one direction of rotation, and the other switch plunger for the opposite direction of rotation. The resultant effect is to open the circuit at the end of either direction of the output shaft. The normally open contacts of the limit switches are wired to the Breeze plug for use with indicating warning circuits. A schematic wiring diagram is shown (fig. 3).

RESTRICTED

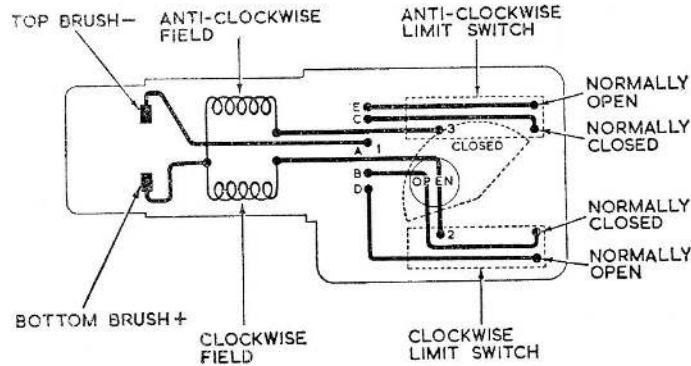

Fig. 3. Schematic wiring diagram

OPERATION

21. Assume that the actuator output shaft has operated in one direction of rotation, one limit switch is now open and the other closed. When the electrical supply to the motor is provided via the "closed" limit switch, the relevant series field is energized and the motor armature rotates. As the first sun gear is integral with the motor armature shaft, the two stages of epicyclic gear, and the worm and wormwheel rotate, thus operating the output shaft.

22. When moving from "close" to "open", the "open" limit switch should operate 6 to 12 degrees before the mechanical stop. The "close" limit switch should close 2 to 20 degrees before the other limit switch opens. This is to ensure that the two limit switches are not open (both series field circuits de-energized) at the same time. A circuit diagram is shown (fig. 4).

23. Due to the kinetic energy of the rotating parts, the output shaft continues to rotate until the appropriate stop face on this shaft comes into contact with the corresponding mechanical stop in the gearbox housing, whereupon the output shaft has reached its full angular travel and further rotation is prevented.

24. Since further rotation of the worm and worm wheel is prevented in this direction the second planet carrier assembly operates as an ordinary spur gear train, and the second

annulus gear slips round between the friction discs until the kinetic energy is dissipated and the rotating parts come to rest.

25. The nominal inclusive angular travel of the output shaft is 92 degrees, but the limit switches are adjusted to switch off after an angular travel of 80 to 86 degrees and the mechanical stops set to 92 degrees to allow for overrun of each switch plunger after the switch has operated.

26. The "normally open" contacts of the limit switches are wired to the warning circuits to indicate which switch is "open" circuit and therefore whether the valve is "open" or "shut".

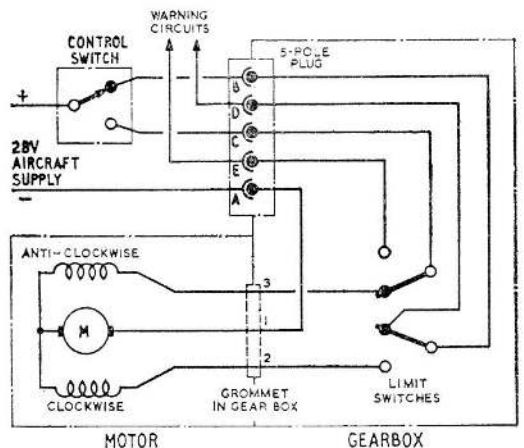

Fig. 4. Circuit diagram

INSTALLATION AND SERVICING

27. If the actuator is properly installed and operated, it should not require attention except during the periodical servicing periods.

28. Visual inspection can be carried out with the actuator mounted in its installation position, as described in the following paragraph.

29. Ensure that all external nuts, screws and locking devices are tight and secure, paying particular attention to the Breeze plug and socket and the limit switch cover.

30. The actuator is sufficiently lubricated during manufacture to avoid the necessity for further lubrication between overhaul periods.

31. During routine inspections, on no account should the limit switch cover be removed unnecessarily and the limit switches

interfered with. The limit switches are set by the manufacturers to give correct angular travel of the output shaft, but, if the settings are altered, these conditions cannot satisfactorily be re-obtained while the actuator is installed in the aircraft.

32. Information on the installation of the actuator will be available by reference to the relevant Aircraft Handbook.

Insulation resistance test

33. On receipt for aircraft operational service, measure the insulation resistance, using a 250 volt insulation resistance tester, it must not be less than 2 megohms.

34. Due to the humidity prevalent in an aircraft when in service, the permissible insulation resistance must not be less than 50,000 ohms.

RESTRICTED

E.S./4

RESTRICTED

(ALL.35, Jan. 59)

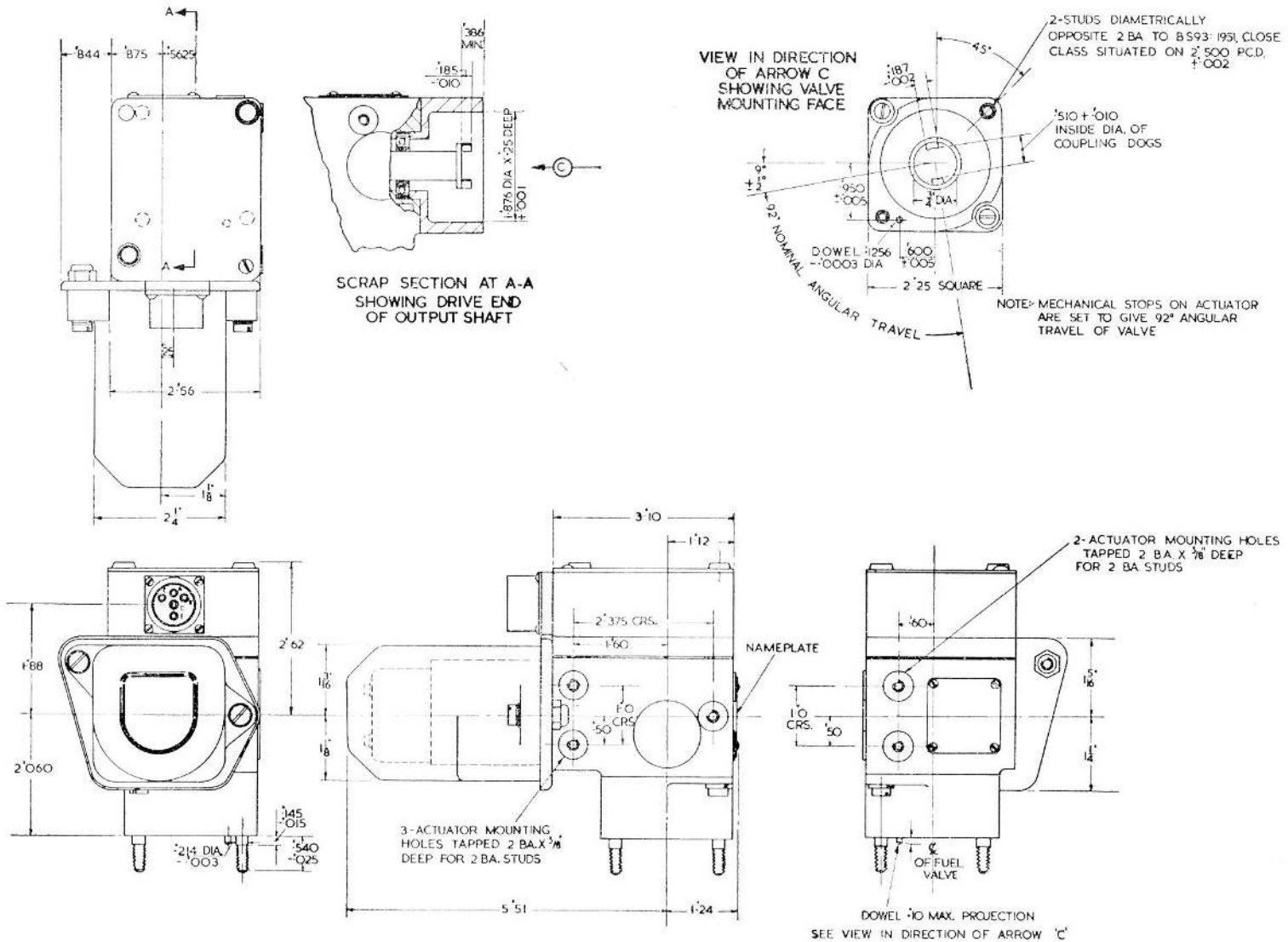

Fig. 5. Installation drawing

This file was downloaded
from the RTFM Library.

Link: www.scottbouch.com/rtfm

Please see site for usage terms,
and more aircraft documents.

