

Chapter 72

ACTUATOR, PLESSEY, TYPE CZ82570/5/F

LIST OF CONTENTS

	<i>Para.</i>		<i>Para.</i>
<i>Introduction</i>	1	<i>Electrical connections</i>	12
Description		Operation	13
<i>General</i>	3	<i>Angular stroke travel</i>	19
<i>Classification</i>	6	Installation	20
<i>Actuator motor</i>	8	Servicing	23
<i>Limit switches</i>	10	<i>Insulation resistance test</i>	26

LIST OF ILLUSTRATIONS

	<i>Fig.</i>		<i>Fig.</i>
<i>General view of actuator</i>	1	<i>End view of switch mechanism</i>	5
<i>Sectional view of actuator</i>	2	<i>Circuit diagram</i>	6
<i>Performance curves</i>	3	<i>Angular stroke travel drawing</i>	7
<i>Schematic wiring diagram</i>	4	<i>Installation drawing</i>	8

LEADING PARTICULARS

<i>Actuator, Plessey, Type CZ/82570/5/F</i>	<i>Ref. No. 5W/</i>
<i>Voltage range</i>	18 to 29 volt d.c.
<i>Voltage at average working load</i>	25 volt d.c.
<i>Power at average working load</i>	30 watts
<i>Average working load</i>	50 lb. in.
<i>Maximum working load</i>	80 lb. in.
<i>Angular stroke travel</i>	90 deg. in 3 sec.
<i>Adjustable angular travel</i>	30 deg. to 360 deg.
<i>Rating</i>	1.5 min. (full load)
<i>Motor—Output</i>	0.0155 h.p. at 15,500 r.p.m.
<i>Weight of complete unit</i>	2 lb. 8 oz.

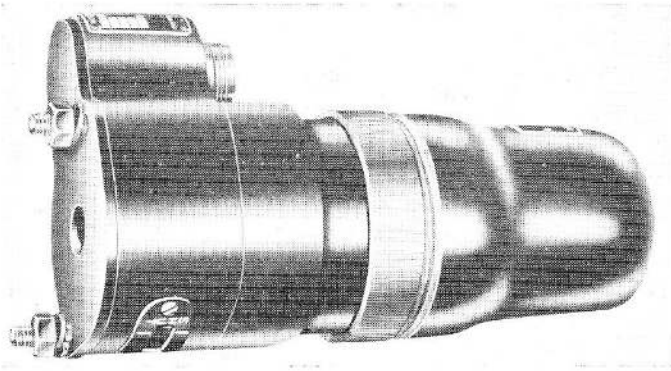

Fig. 1. General view of actuator

Introduction

1. The Plessey, Type CZ82570/5/F actuator belongs to the Panther Series as described in A.P.4343, Vol. 1, Sect. 17, Chap. 1, App. 6.
2. The actuator is identical in design to the CZ54709/5 universal actuator, which is

described in Chap. 10 of this section, except that certain items which are liable to deteriorate on contact with oil or grease, such as gaskets, sealing washer, switch housing assembly and grease guard assembly have been changed to render the actuator resistant to ester base lubricants.

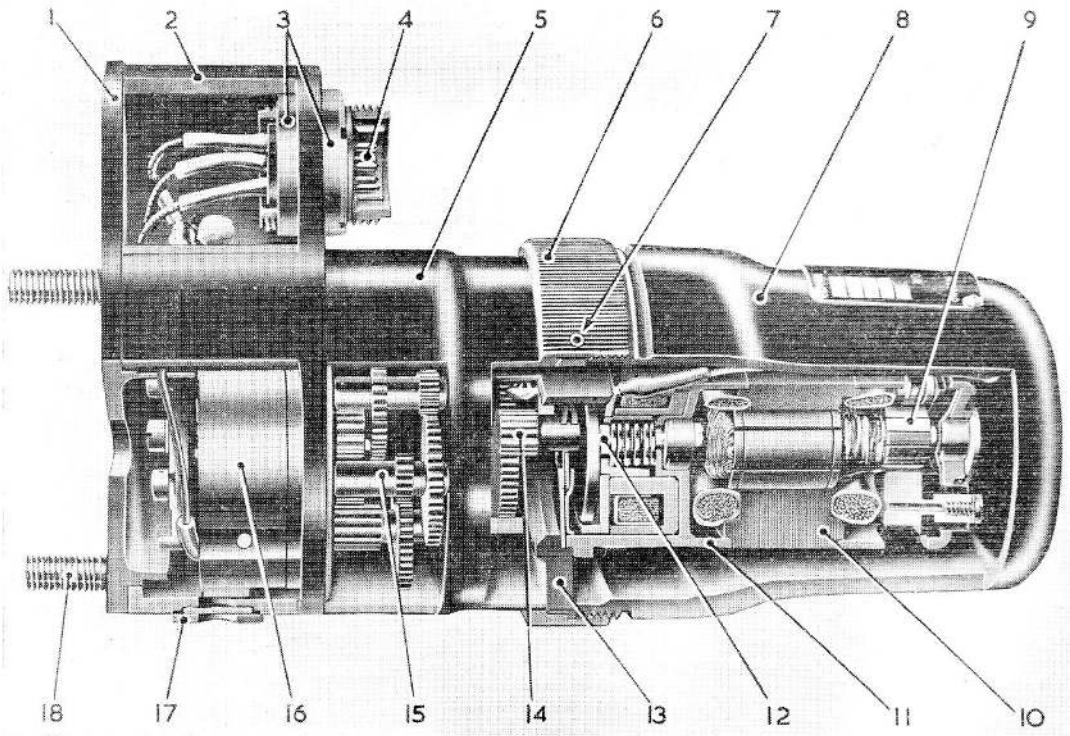

Fig. 2. Sectional view of actuator

RESTRICTED

ANNOTATIONS FOR FIG. 2

- | | | | |
|---|---------------------|----|-----------------------|
| 1 | FLANGE PLATE | 10 | YOKE ASSEMBLY |
| 2 | SWITCH HOUSING | 11 | MOTOR HOUSING |
| 3 | LOCKING RING NUTS | 12 | BRAKE ASSEMBLY |
| 4 | PLUG | 13 | SPIGOT MOUNTING PLATE |
| 5 | GEARBOX HOUSING | 14 | MOTOR PINION GEAR |
| 6 | COVER RETAINING NUT | 15 | GEARBOX |
| 7 | LOCKING SCREW | 16 | LIMIT SWITCH ASSEMBLY |
| 8 | COVER | 17 | WINDOW AND BEZEL |
| 9 | COMMUTATOR | 18 | MOUNTING STUD |

DESCRIPTION

General

3. The CZ82570/5/F has been designed to provide remotely controlled rotary motion over ranges of 30 degrees to 360 degrees mechanical, according to application requirements in aircraft.

4. The extreme actuator positions are controlled by two single-pole, change-over, snap-action limit switches, and provision is made for visual indication at the control position. A window in the actuator casing indicates the two extreme positions of the actuator drive pin; this pin engages in the dog shaft of the component being actuated.

5. The motor incorporates an electromagnetic brake which rapidly stops the motor, and effectively reduces over-run of the drive pin.

Classification

6. The actuator is classified by a type number, the basic standard Panther actuator being referred to as CZ82570. To indicate various plug positions (necessary for the particular applications for which the Panther actuator has been designed) a qualifying number has been added. Thus CZ82570/5 refers to one particular plug position.

7. In addition to a qualifying number, each actuator has a suffix letter to indicate the application stroke setting, front end fitting and rear end fitting. This is shown when the actuator is classified as CZ82570/5/F.

Actuator motor

8. The low power motor, Type C1606B/1, which is of the split-field series wound, reversible type, incorporating an electro-

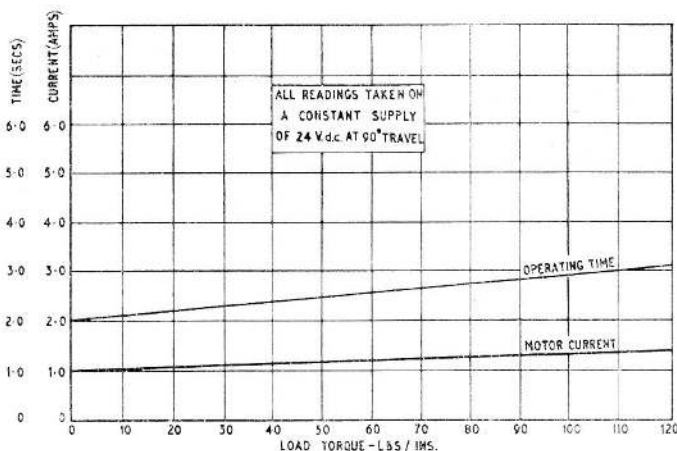

Fig. 3. Performance curves

magnetic brake, which brings the machine rapidly to rest when the electrical supply is discontinued, thus effectively preventing over-run of the output shaft.

9. The performance figures for actuator and motor are contained in Leading Particulars.

Limit switches

10. The switch housing contains the two limit switches, the visual indicator and switch operating mechanism. The electrical plug together with its associated wiring to the limit switches and motor also protrudes into the housing.

11. The switches are of the single-pole, snap-action type, and are so wired as to enable warning lights to be incorporated in the remote control position. The circuit diagram is a typical aircraft installation arrangement and shows the limit switches connected to a remote indicator.

Electrical connections

12. The wiring arrangements are shown (fig. 4). From the limit switches the leads to the motor pass through holes in the walls of the switch housing and actuator body to a terminal block attached to the rear of the actuator body by two screws. The lower half of this block is shrouded by the spigot mounting plate. A letter and number coding system is used for identifying the cable runs.

OPERATION

13. Consider an operating cycle to commence with the actuator in the position in fig. 6, i.e. in the "SHUT" limit condition. The motor is de-energized and the limit switch sleeve is held in its extreme right hand position by the left hand adjusting plate.

14. When the remote control switch is moved to "OPEN", the motor is energized via the normally closed contacts on the "OPEN" limit switch and the final gear rotates clockwise as seen (fig. 6).

Note . . .

The sequence of operations should be followed in conjunction with circuit diagram (fig. 6).

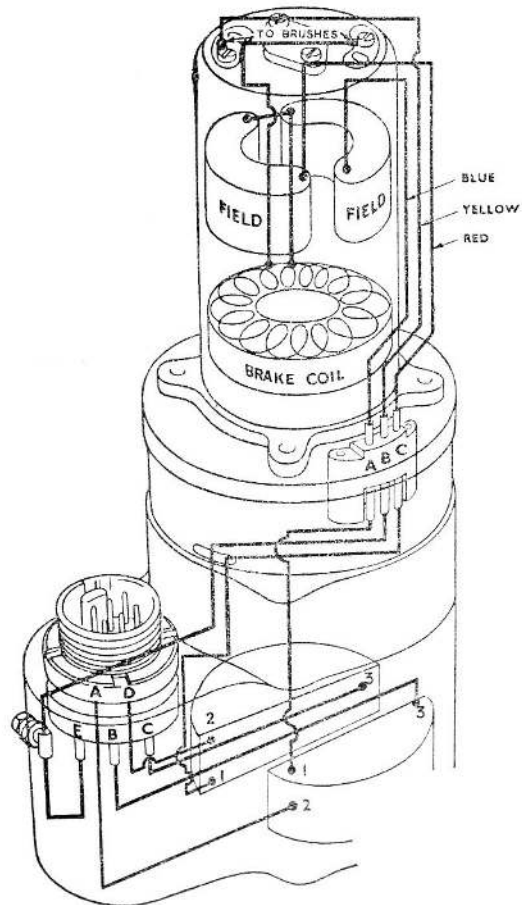

Fig. 4. Schematic wiring diagram

15. The adjusting plate driver, together with the adjusting plates, rotates clockwise with the final gear and releases the sleeve pin, the switch pin is then centralised by the scissor spring. The adjusting plate driver continues rotating until the right-hand adjusting plate strikes the sleeve pin. The sleeve pin moves to the left and rotates the limit switch sleeve into contact with the "OPEN" limit switch (fig. 5). The "OPEN" limit switch changes over, disconnecting the motor supply and closing the "OPEN" indicating circuit (fig. 6).

16. If now, the remote control switch is moved to "SHUT", the motor is energized via the normally-closed contacts on the "SHUT" limit switch (fig. 6) and the switch operating mechanism rotates anti-clockwise towards the

RESTRICTED

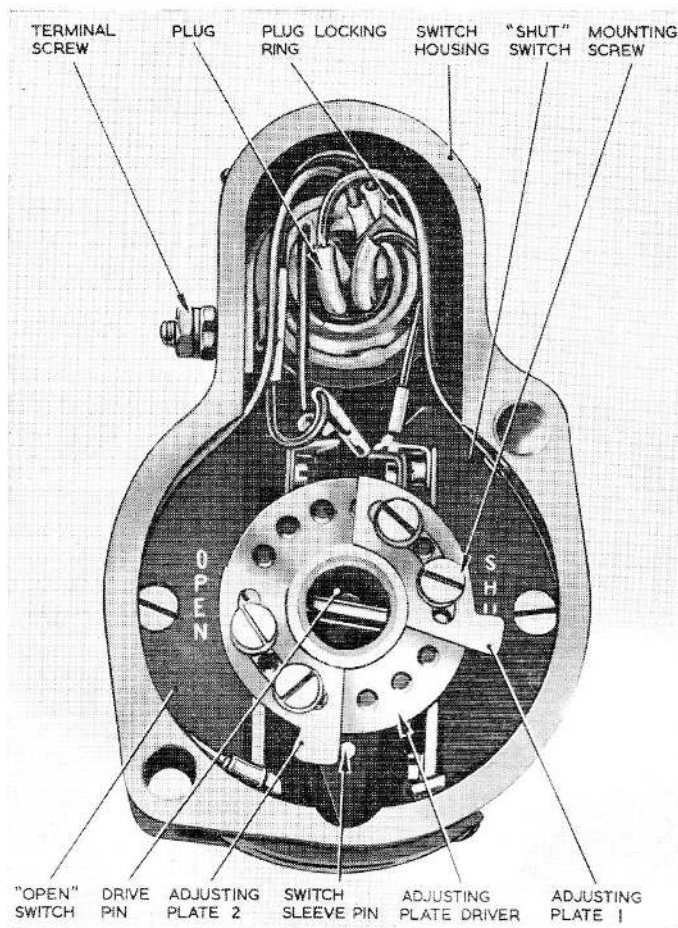

Fig. 5. End view of switch mechanism

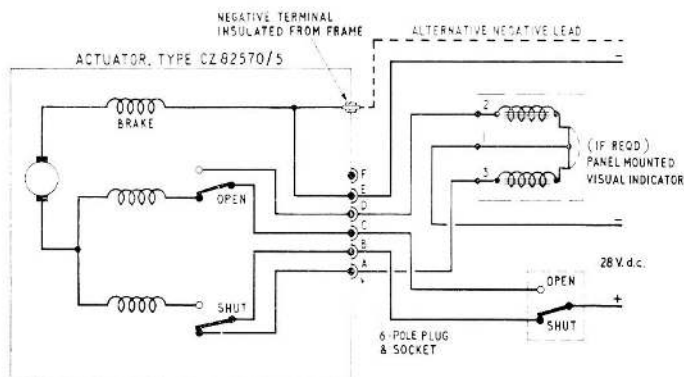

Fig. 6. Circuit diagram

“SHUT” limit position. This sequence of operations is repeated for each operating cycle of the actuator.

17. It can be seen from fig. 5 that the range of movement of the drive pin depends upon the positions of the adjusting plate on the adjusting plate driver. The range of movement is a minimum when both plates are so close as to be in permanent contact with the limit switch sleeve pin. In this case the amount of travel is that necessary for the switch sleeve to operate both switches, i.e. 30 degrees mechanical inclusive. On the other hand with the adjusting plates moved to the opposite extreme, maximum travel is obtainable.

Angular stroke travel

18. The CZ82570/5/F actuator has 90 degrees angular travel in 3.0 seconds (fig. 7).

INSTALLATION

19. Information on installation of the

Panther Series of actuators is contained in A.P.4343, Vol. 1, Sect. 17, Chap. 1, App 6.

20. For details of installing this type of actuator in a particular aircraft, reference should be made to the relevant Aircraft Handbook.

21. Installation drawing of the CZ82570/5 actuator is shown (fig. 8).

SERVICING

22. The servicing of this type of actuator is as for the Panther Series, described in A.P.4343, Vol. 1, Sect. 17, Chap. 1, App. 6

23. The following list details the changes in spares which are liable to deteriorate on contact with oil or grease, for spares which enable the actuator to become more resistant to ester base lubricants.

<i>Description</i>	<i>Plessey Spares Part Nos.</i>		<i>Quantity</i>
	<i>New</i>	<i>Old</i>	
Gasket	IZ.82491	Z.57588	1
Gasket	IZ.81843	Z.57219	1
Gasket	IZ.81842	Z.62838	1
Grease guard assembly (includes sealing washer)	ICZ.82483 IZ.82487	CZ.67609 Z.67612	1 1
Switch housing assembly	ICZ.82557	ICZ.82458	1
Epihard Clear Lacquer 480/1	99/0955	Kearsley's lacquer various Part Nos.	As reqd.
Epihard Accelerator 480/2	99/0023		As reqd.
Hermitite 1326, <i>or</i>	99/0222		As reqd.
Duralac 3389	99/0221		As reqd.

RESTRICTED

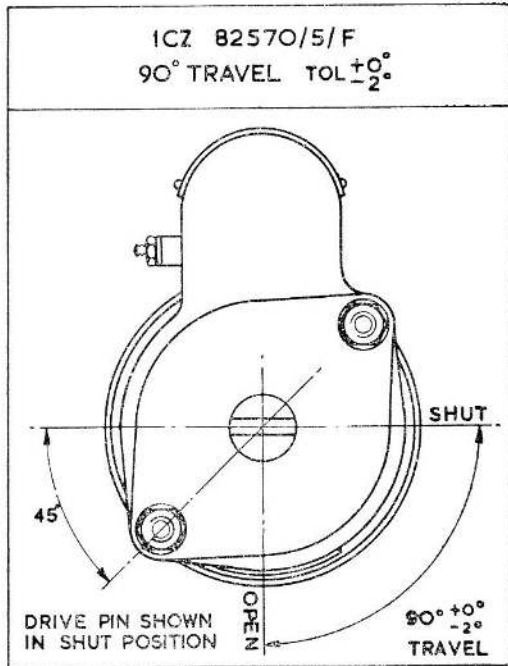

Fig. 7. Angular stroke travel drawing

24. Mixing instructions for Epihard clear lacquer 480/1 with Accelerator 480/2. This lacquer should be mixed in sufficient quantity (for one day's use only), as follows : —

3 parts (by volume) lacquer 480/1 to

1 part (by volume) lacquer 480/2.

Insulation resistance test

25. Using a 250 volt insulation resistance tester, measure the insulation resistance between the electrical circuit and earth, it must not be less than 2 megohms, when first installed in the aircraft.

26. Due to the humidity prevalent in aircraft and at dispersal points, the minimum insulation resistance permitted is 50,000 ohms.

27. These tests can best be effected at the Breeze plug while still installed in the aircraft.

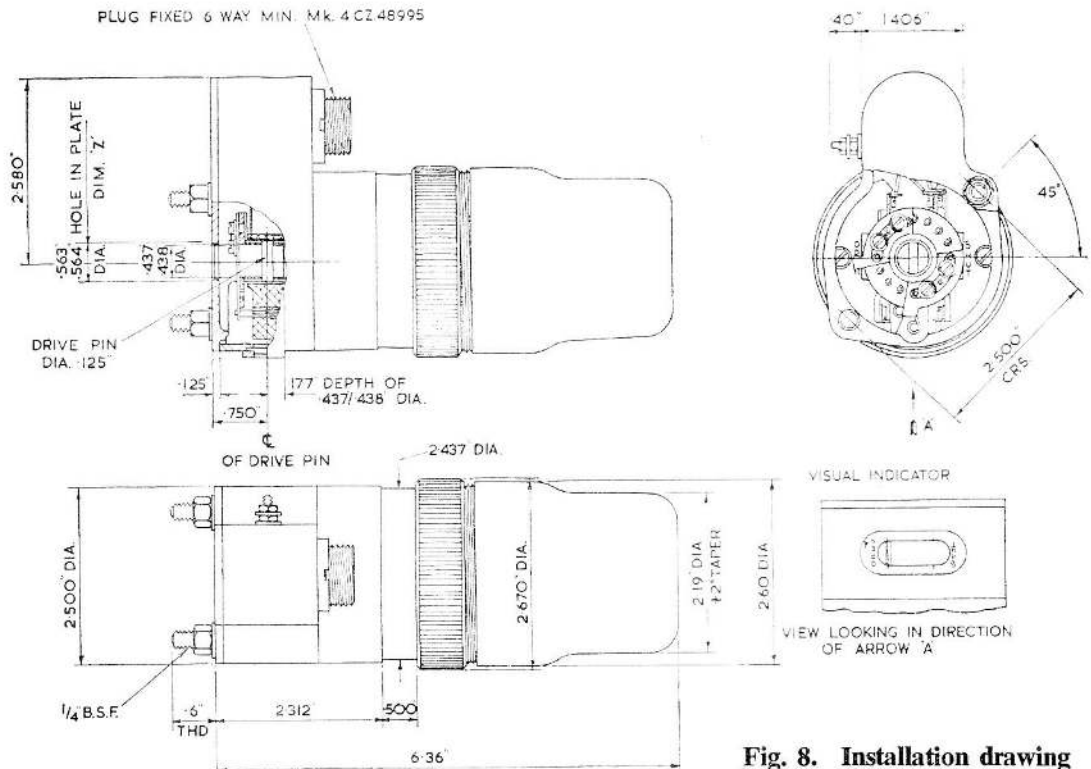

Fig. 8. Installation drawing

This file was downloaded
from the RTFM Library.

Link: www.scottbouch.com/rtfm

Please see site for usage terms,
and more aircraft documents.



**TELEBRIEF
CONNECTIONS**

E