

## Chapter 73

## RETRACTION UNIT, ROTAX, TYPE C8901

## LIST OF CONTENTS

	<i>Para.</i>		<i>Para.</i>
<i>Introduction</i> ... ..	1	<b>Installation</b> ... ..	8
<b>Description</b> ... ..	2	<i>Electrical connections</i> ... ..	9
<i>Motor and brake</i> ... ..	5	<b>Servicing</b> ... ..	10
<i>Operation</i> ... ..	6	<i>Millivolt drop test</i> ... ..	17
<i>Limit switches</i> ... ..	7	<i>Insulation resistance test</i> ... ..	18

## LIST OF ILLUSTRATIONS

	<i>Fig.</i>		<i>Fig.</i>
<i>Retraction unit, Type C8901</i> ... ..	1	<i>View of limit switches (unit retracted)</i> ... ..	3
<i>View of limit switches (unit extended)</i> ... ..	2	<i>Circuit diagram</i> ... ..	4

## LEADING PARTICULARS

<b>Retraction unit, Type C8901</b> ... ..	<i>Ref. No. 5UD/6230.</i>
<i>Normal voltage (no load)</i> ... ..	28 volts d.c.
<i>Current (no load)</i> ... ..	1.05 amp. (max.).
<i>Motor rating</i> ... ..	10 minutes.
<i>Angular movement (lamp arm)</i> ... ..	85 deg. $\pm$ 2 deg.
<i>Brush spring load (normal brush length)</i> ... ..	3½ to 4½ oz.
<i>Resistance of windings—</i>	
<i>Armature</i> ... ..	1.620 ohms $\pm$ 10 per cent.
<i>Field windings ("in" and "out")</i> ... ..	1.492 ohms $\pm$ 10 per cent.
<i>Brake</i> ... ..	2.92 ohms $\pm$ 10 per cent.
<i>Brush grade</i> ... ..	C.M.3 H.H.A.M.
<i>Brush length (new)</i> ... ..	0.390 in.
<i>Minimum brush length</i> ... ..	0.281 in.
<i>Overall dimensions:—</i>	
<i>Length (to quadrant pivot)</i> ... ..	5.437 in.
<i>(pivot to end of quadrant)</i> ... ..	4.140 in.
<i>(travel of quadrant from pivot)</i> ... ..	85 deg.
<i>Width</i> ... ..	4.875 in.
<i>Height</i> ... ..	4.437 in.
<i>Weight</i> ... ..	4½ lb.

RESTRICTED

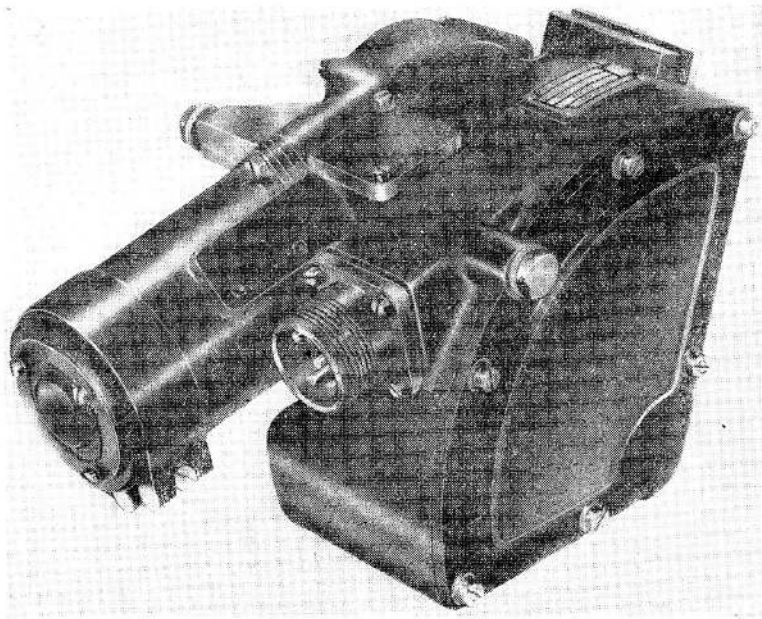

Fig. 1. Retraction unit, Type C8901

### Introduction

1. The unit (*fig. 1*) is a 28 volt d.c. rotary actuator having a gear ratio of 2,040 : 1, which is used to extend and retract a landing lamp, Type J, Mk. 2 or K, Mk. 2, situated in the aircraft wing. Reversal of rotation is effected by switching in the appropriate field windings of the motor.

### DESCRIPTION

2. The armature shaft, supported between ball bearings, extends into the gear box, driving the lamp arm via a worm wheel, compound gear, and quadrant gear. Integral with the worm wheel is an overload clutch, set to slip when the torque exceeds 180 lb. in. This torque represents a load of 35 lb., at the centre of the glass of the complete landing lamp which the unit drives, and corresponds to an air speed of approximately 160 m.p.h.

3. The total travel of the lamp arm is 85 degrees, and provision is made for an intermediate "low beam" position of 78 degrees. The time of operation on no load is a maximum of 3.8 seconds.

4. The switch compartment contains three sets of contacts and a filament lamp switch all operated by an actuating arm fixed on the lamp arm shaft, and therefore the switching of all contacts is dependent on the position of the lamp arm. A circuit diagram is given in *fig. 4*.

### Motor and brake

5. The motor is a 28 volt d.c., 2-brush, 4-pole, split field series machine incorporating an electro-magnetic disc type brake. The brake pulls in with a current of 1.5 amp. (max.) through the coil, and does not drop-out till the current is reduced below 0.25 amp.

### Operation

6. Operation of the unit is effected by remote switching in the cockpit, via the switch compartment in the main casting of the actuator. The switches are so arranged that the external lamp arm will move direct from any selected position to either of the two remaining positions. When double filament lamps are used the required filament can be selected remotely.

### Limit switches

7. The operation of the limit switches can be followed from the views of the mechanism in *fig. 2* and *3*. With the lamp in the retracted "off" position, as in the circuit diagram in *fig. 4*, the "in" limit switch is open (*fig. 3*). When the motor "out" field is energized by operation of the external switch, the lamp will be extended, and the filament lamp contacts closed by rotation of the actuating arm. If "low" beam has been selected, the lamp will be extended until the arm changes over the mid-position limit switch after 78 deg. of travel; if "high" beam has been

**RESTRICTED**

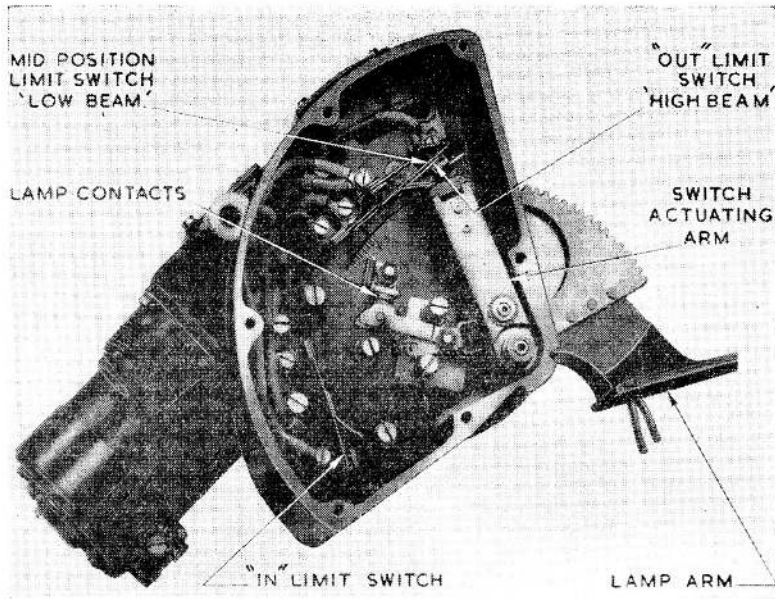

Fig. 2. View of limit switches (unit extended)

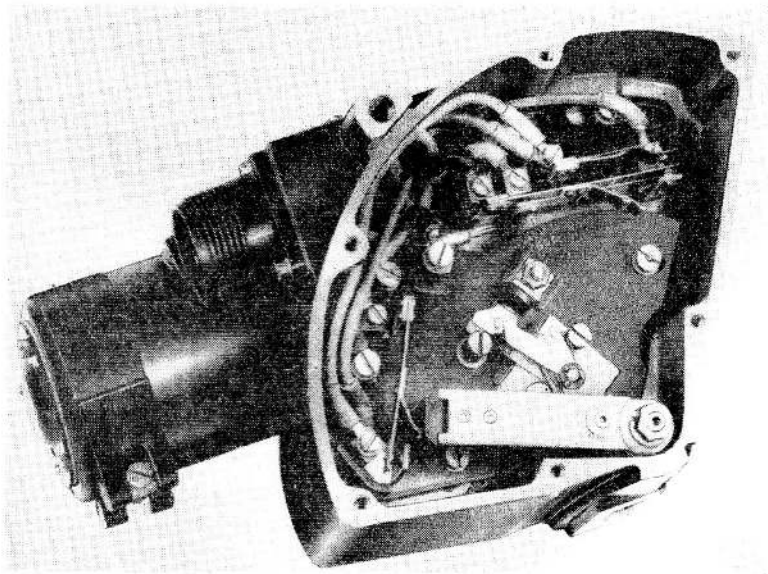

Fig. 3. View of limit switches (unit retracted)

**RESTRICTED**

selected, it will continue until the arm finally breaks the "out" limit switch after 85 deg. of travel to de-energize the motor field (fig. 2). When the external switch is then operated to select the "low" beam or retracted "off" position, the "out" field is energized and the mechanism operates in the reverse sequence until the lamp is fully retracted and the actuating arm finally breaks the "in" limit switch.

Mark the brushes to ensure that they are replaced in the same order, after removal of any excess carbon dust found in the brush box. Loose carbon dust can be removed with a jet of dry compressed air; wipe brushes and brush boxes with a cloth moistened with pure lead-free gasoline.

11. The minimum length beyond which brushes must not be used is 0.281 in. from a new length of 0.390 in. Brushes should be

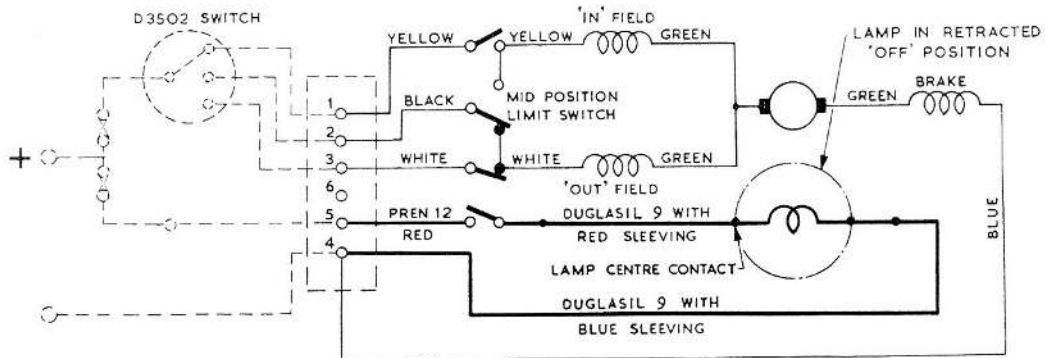

NOTE: CABLE PREN 6 UNLESS STATED OTHERWISE. IDENTIFICATION SLEEVES FITTED BOTH ENDS

Fig. 4. Circuit diagram

### INSTALLATION

8. The installation details will be determined by the landing lamp to which the unit is fitted. Eight csk/hd. screws, 6 B.A.  $\times$  0.250 in. long and 6 cup washers are supplied loose with each unit for assembly of the lamp outer body. There are two external bosses integral with the main body casting, each tapped 0.250 in. B.S.F.  $\times$  0.550 in. deep with their associated screws provided for mounting purposes.

### Electrical connections

9. All external electrical connections are made via a 6-pole Breeze plug (Ref. No. 5X/6041). Two additional external cable leads are provided for lamp connections at the lamp arm end of the unit.

### SERVICING

10. This retraction unit should be serviced in accordance with the general chapter in A.P.4343, Vol. 1, Sect. 17, Chap. 1, and the instructions contained in the relevant servicing schedule. Remove the brush cover band, and remove and examine the brushes for freedom of movement in the brush boxes.

renewed at periods prescribed in the relevant Servicing Schedule and whenever examination reveals that they will not remain serviceable for the period that must elapse before the next servicing.

12. The brush spring load taken with the end loop of the spring level with the top of the brush box must be between  $3\frac{1}{2}$  and  $4\frac{1}{2}$  oz.

13. Replace brushes in their respective boxes, assemble the cover band and ensure that the retaining screw is secure and tight.

14. Remove the gear box cover and lightly lubricate compound gears with grease XG-276 (Ref. No. 34B/9425139).

### Note . . .

*Take care not to damage the cover gasket on removal.*

15. The clutch is set to slip at  $180 \pm 20$  lb. in. and should not normally require adjustment. Replace gear box cover, and lightly smear gasket with "Wellseal" jointing compound. (Do not lubricate clutch.)

16. Remove the limit switch cover and lubricate the change-over switch fulcrum pin,

**RESTRICTED**

using one drop of oil OX-14 (Ref. No. 34B 9100589). Replace the limit switch cover and tighten all securing screws.

**Millivolt drop test**

**17.** With 20 amp. passing through the toggle switch, the millivolt drop across the

contacts should not exceed 90 millivolts.

**Insulation resistance test**

**18.** The insulation resistance, measured with a 250 volt insulation resistance tester between the positive terminals and the frame, should not be less than 50,000 ohms.

This file was downloaded  
from the RTFM Library.

Link: [www.scottbouch.com/rtfm](http://www.scottbouch.com/rtfm)

Please see site for usage terms,  
and more aircraft documents.

