

Chapter 77

ACTUATOR, PLESSEY, TYPE 1CZ135792

LIST OF CONTENTS

	<i>Para.</i>		<i>Para.</i>
<i>Introduction</i>	1	Operation	5
Description	2	Installation	6
<i>Limit switch operating mechanism</i>	3	Servicing	7
<i>Electrical connections</i>	4	<i>Insulation resistance test</i>	8

LIST OF TABLES

	<i>Table</i>
<i>Plug connections</i>	1

LIST OF ILLUSTRATIONS

	<i>Fig.</i>		<i>Fig.</i>
<i>General view of actuator</i>	1	<i>Limit switch operating mechanism</i>	3
<i>Sectional view of actuator</i>	2	<i>Installation details</i>	4

LEADING PARTICULARS

Actuator, Plessey Type 1CZ135792	Ref. No. 5W/2594
<i>Operating voltage (nominal 24V d.c.)</i>	18 — 29V d.c.
<i>Output (nominal)</i>	50 lb. in.
<i>Rating of motor</i>	1.5 min.
<i>Ambient temperature range</i>	-70° to +90° C
<i>Angular travel (1CZ135792)</i>	0°, 90°, 180°
<i>(for other types see A.P.4343, Vol. 1, Sect. 17, Chap. 1, App. 11)</i>	
<i>Time of travel 180 deg. (1CZ135792)</i>	4 sec.
<i>Weight</i>	2 lb. 4 oz.
<i>Fixing centres</i>	2.50 in.

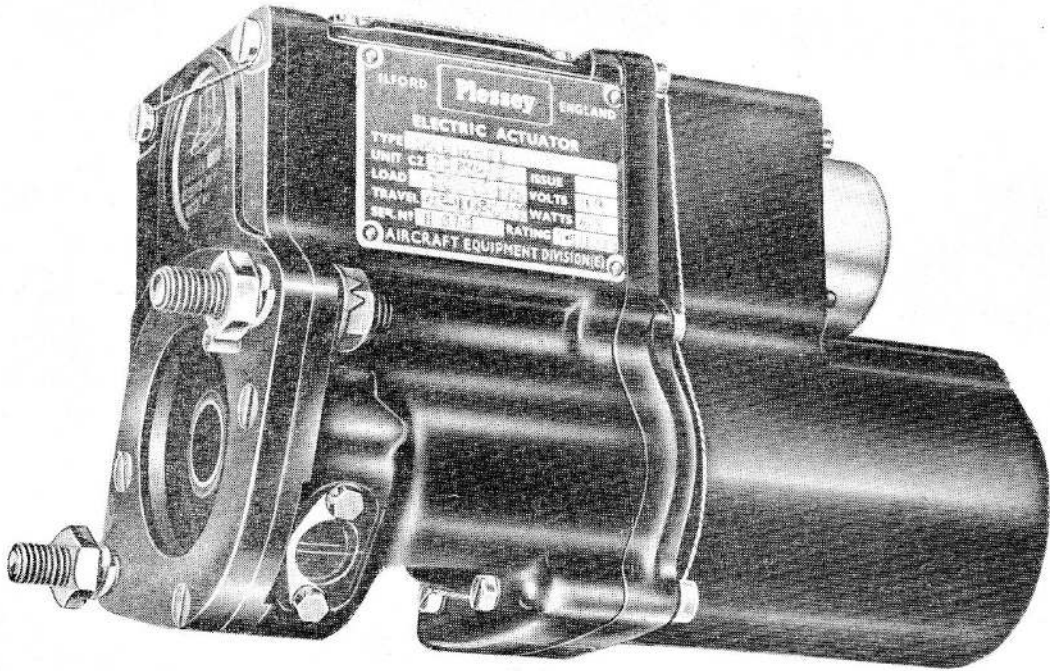

Fig. 1. General view of actuator

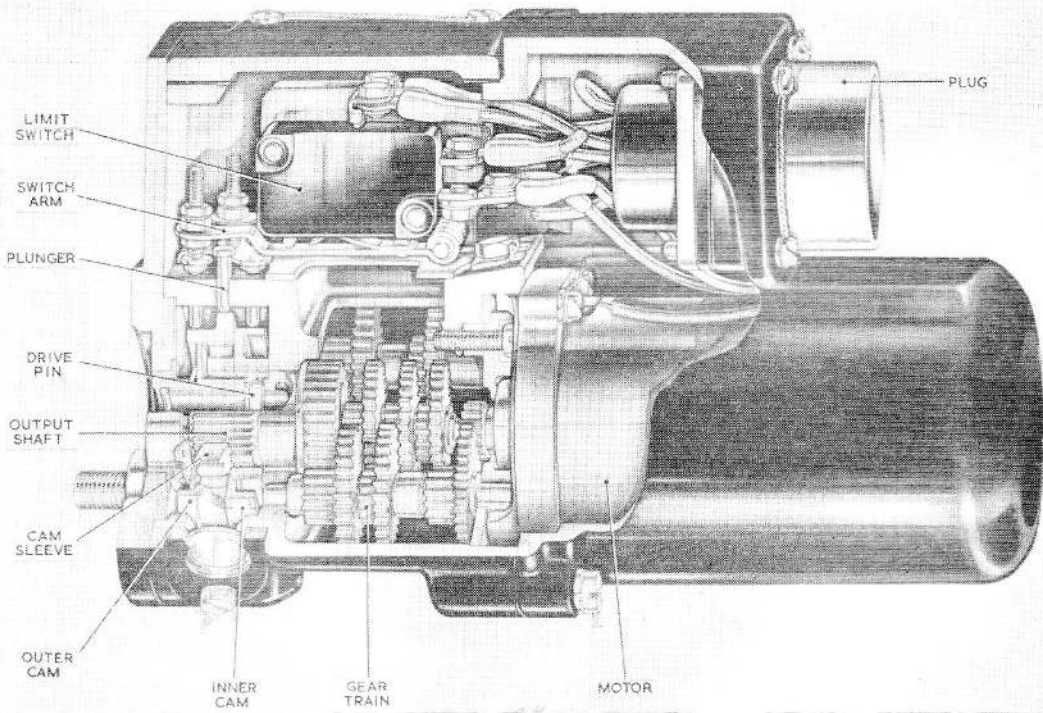

Fig. 2. Sectional view of actuator

RESTRICTED

Introduction

1. The actuator, Type 1CZ135792, belongs to the Squirrel series of actuators as described in A.P.4343, Vol. 1, Sect. 17, Chap. 1, App. 11.

DESCRIPTION

2. A sectional view of the actuator is shown in fig. 2. The general construction is as described in the Appendix on Squirrel actuators, to which reference should be made for further information. The motor brushes on this actuator are of High Altitude

“Morganite” carbon, and electrical connection is made by a tag attached to the flexible leads.

Limit switch operating mechanism

3. The limit switch cams are provided with roller followers (fig. 3) situated at one extremity of a short pivoted arm. The other extremity of the arm bears against an adjustable stud attached to the switch trip arm.

Electrical connections

4. The internal connections of the actuator are given in Table 1 below. The external

TABLE 1
Plug connections

<i>Pin No.</i>	<i>Lead Colour and Sleeve Coding</i>	<i>Circuit Function</i>
1	Blue (Motor)	—ve return from armature
2	Red (Com)	Clockwise rotation (0° — 180°) or Clockwise rotation (int. — 180°)
3	Yellow (Com)	Clockwise rotation (0° — int.) or Counter-clockwise rotation (180° — int.)
4	Green (Com)	Counter-clockwise rotation (180° — 0°) or Counter-clockwise rotation (int. — 0°)
5	White (N/O)	Indicator open (180°)
6	Black (N/O)	Indicator intermediate
7	Brown (N/O)	Indicator shut (0°)
8	Orange (N/C)	Continuous rotation (clockwise)
9	Violet (N/C)	Continuous rotation (counter-clockwise)

Note . . .

By “intermediate” is meant any stroke setting between 5° and 175° . For example, on /4 actuator, pins 1 and 3 provide clockwise rotation 0° — 125° , and pins 1 and 4 counter-clockwise rotation 125° — 0° .

connections are made by means of a Plessey 9-way socket CZ56101 (Ref. No. 5X/6379), which mates with a 9-way plug CZ28097 (Ref. No. 5X/6306), mounted on the actuator motor cover.

OPERATION

5. The operation described in A.P.4343, Vol. 1, for Squirrel actuators is applicable to this actuator.

INSTALLATION

6. The instructions given in A.P.4343, Vol. 1, for Squirrel actuators are applicable to this actuator.

SERVICING

7. The servicing of this actuator is as given for Squirrel actuators in A.P.4343.

Note . . .

It is recommended that the actuator be removed for bay servicing in accordance with the relevant Aircraft Servicing Schedule.

Insulation resistance test

8. With the actuator installed in the aircraft, an insulation resistance test can be affected at the Breeze plug. On first installation, using a 250 volt insulation resistance tester, the insulation resistance must not be less than 2 megohms.

9. Due to the humidity prevalent in the aircraft and at dispersal points, the insulation resistance of the actuator, after installation, must not be less than 50,000 ohms.

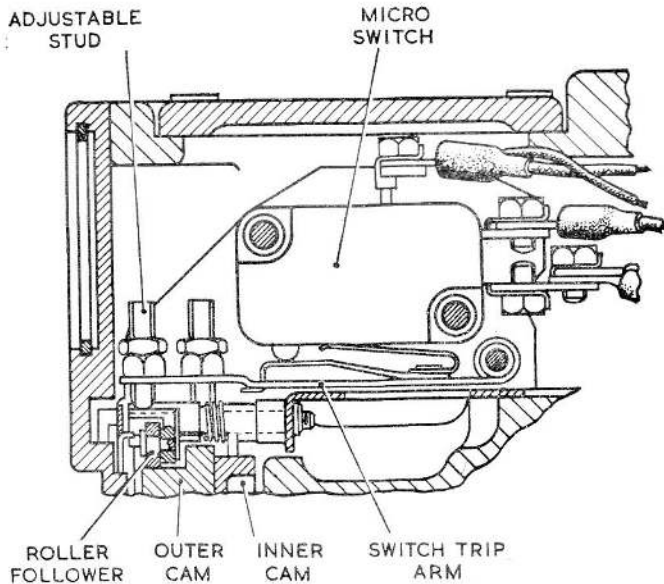

Fig. 3. Limit switch operating mechanism

RESTRICTED

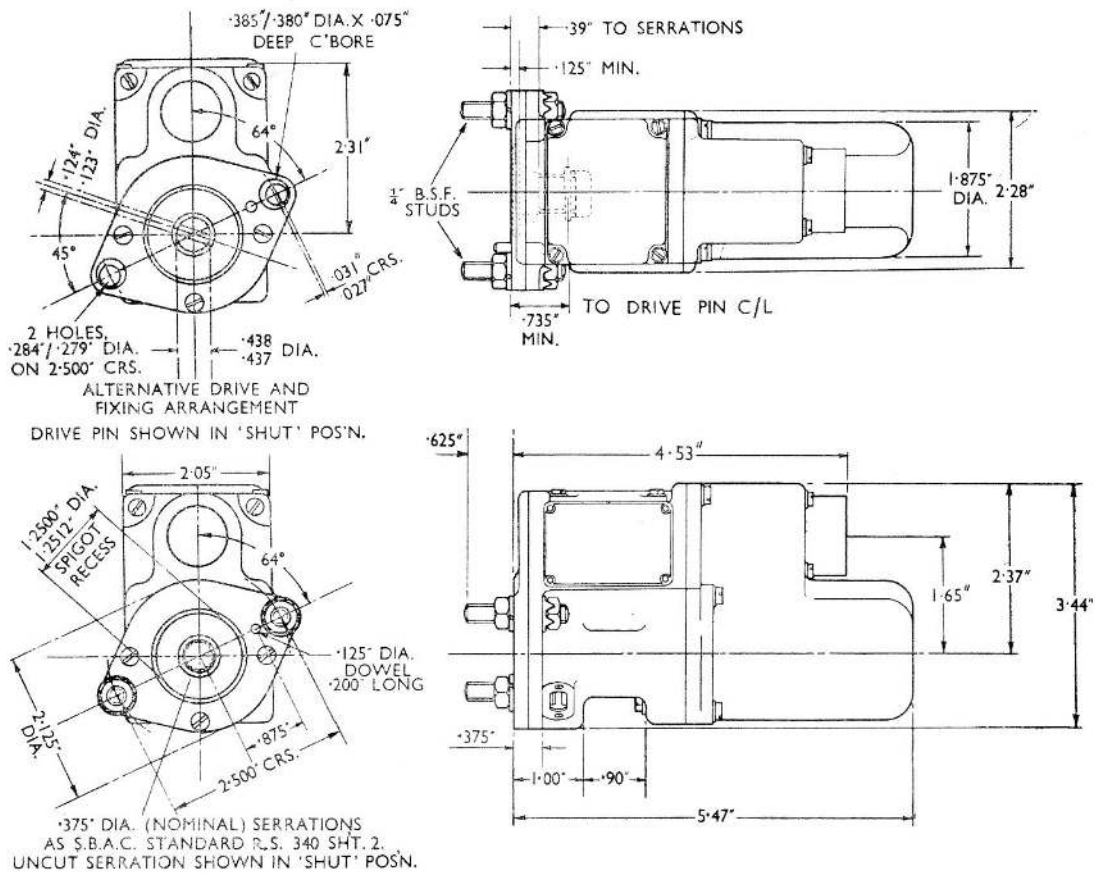

Fig. 4. Installation details

This file was downloaded
from the RTFM Library.

Link: www.scottbouch.com/rtfm

Please see site for usage terms,
and more aircraft documents.

