

## Chapter 90

## ACTUATOR, WESTERN, TYPE U.A.5456

## LIST OF CONTENTS

	<i>Para.</i>		<i>Para.</i>
<i>Introduction</i> .....	1	<i>Limit switches</i> .....	7
<b>Description</b> .....	<b>2</b>	<b>Operation</b> .....	<b>8</b>
<i>Motor unit</i> .....	3	<b>Installation</b> .....	<b>10</b>
<i>Gearbox unit</i> .....	4	<b>Servicing</b> .....	<b>11</b>
<i>Output unit</i> .....	5	<i>Testing</i> .....	13
<i>Mounting</i> .....	6	<i>Insulation resistance after installation</i>	14

## LIST OF ILLUSTRATIONS

	<i>Fig.</i>
<i>Sectional view of actuator</i> .....	1
<i>Installation drawing</i> .....	2
<i>Circuit diagram</i> .....	3

## LEADING PARTICULARS

<i>Actuator, Western, type U.A.5456</i> .....	<i>Ref. No.</i> 5W/2714
<i>Voltage, normal</i> .....	28V d.c.
<i>Weight</i> .....	2 lb. 10 oz.
<i>Working load, normal</i> .....	50 lb. in.
<i>Working load, max</i> .....	75 lb. in.
<i>Angular travel</i> .....	180 deg. $\pm 1$ deg.
<i>Time for 180 deg. travel at 50 lb. in. load</i> .....	4.5 sec.
<i>Setting of mid-position switch</i> .....	90 deg. $\pm 5$ deg.
<i>Rating of motor</i> .....	1 min.

## Introduction

1. The universal rotary actuator, Western type UA.5456, is designed to provide a torque, clockwise or anti-clockwise as necessary, for situations requiring a rotational movement under remote control, within the limits given under Leading Particulars. It is rated to operate for one minute at a nominal load of 50 lb. in. with current consumption not exceeding 2.25 amperes.

## DESCRIPTION

2. The actuator comprises three independent assemblies, namely motor unit, gearbox unit and output unit. These are bolted together to form one complete unit having the motor axis coincident with the output shaft.

### Motor unit

3. The motor unit consists of a fractional horse-power motor, output pinion and motor housing. The motor operates from a d.c. supply ranging from 18 to 29 volts. It is of the reversible, series split-field type and incorporates an electro-magnetic brake to

maintain accurate angular travel. The field assembly is secured to the motor housing and fitted around the armature, the latter being free to rotate between two ballraces. Both ballraces are housed in end plates which are held in position by tie rods. The rear end plate also supports the brake solenoid assembly and carries, on its inner face, the brushgear assembly. The brushes are high altitude electro-graphic type with adjustable spring pressure. The brake comprises a spring loaded brake shoe having a friction lining on the face adjacent to the brake disc. The brake disc is secured to, and rotates with, the armature shaft. Operation of the brake is controlled by the brake solenoid which is connected in parallel with the armature.

### Gearbox unit

4. The gearbox unit consists of a five-stage epicyclic gearbox and the housing, and is bolted to the output unit and to the motor unit. The gearbox consists of five carriers, each supporting four planet gears, all within an annulus. Motor input drive to the gears is via a pinion on the armature spindle

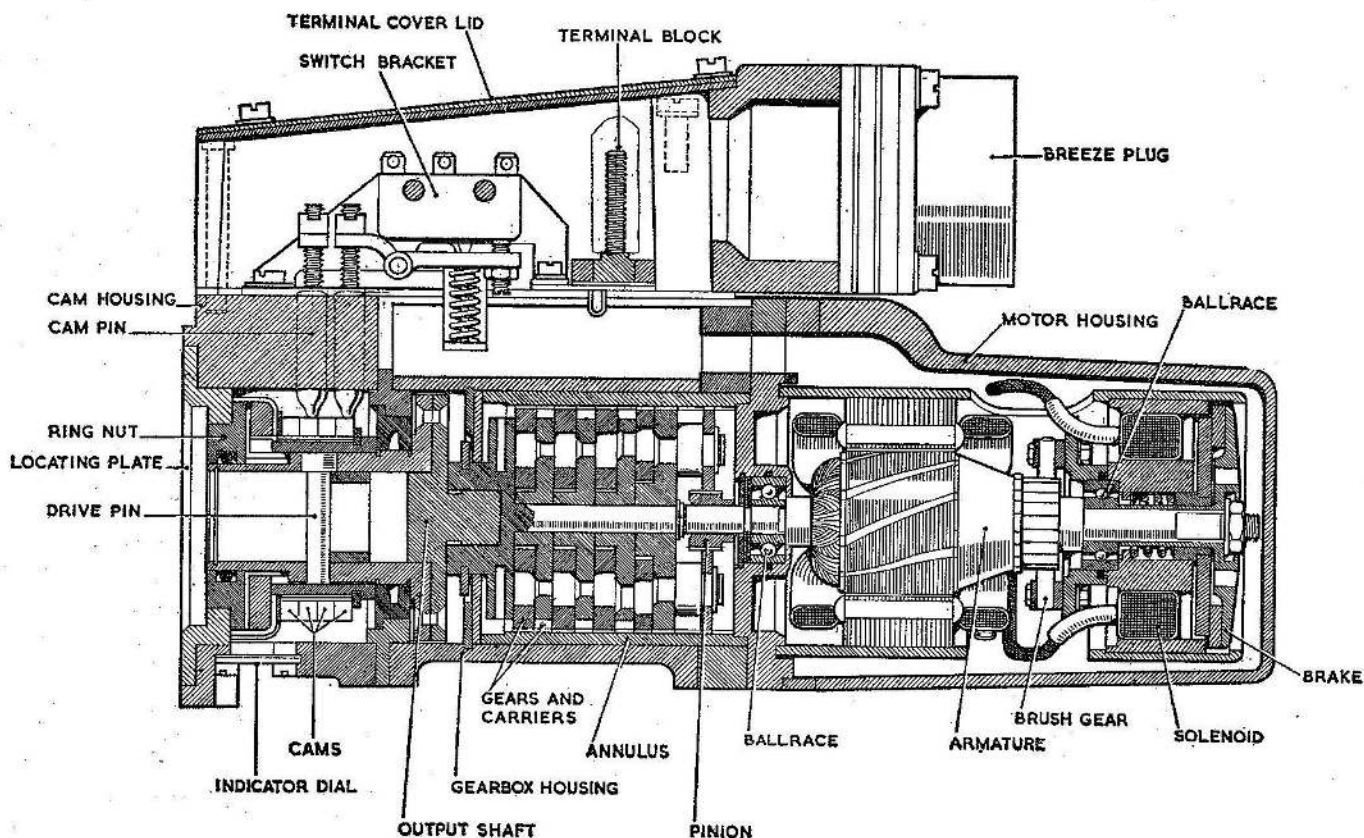

Fig. 1. Sectional view of actuator

RESTRICTED

in engagement with the first stage planet gears. Output from the gear train is imparted direct to the squared end of the output shaft at a total reduction ratio of 1895:1.

### Output unit

5. The output unit comprises an output shaft, electrical connection for external supply, limit switches, cams, open and shut indicators, housing and cover. The output end of the unit contains the drive pin and an insert. The latter can be plain or serrated as shown in Installation drawing Fig. 2.

### Mounting

6. The actuator is attached to the actuated component by a mounting flange and two  $\frac{1}{4}$  in. B.S.F. studs at 2.50 in centres.

### Limit switches

7. The four limit switches are of the snap action micro type, each operated by a cam on the output shaft, via a cam pin and lever.

## OPERATION

8. The motor drives the output shaft via the gearbox. Two of the four limit switches break the motor circuit, one of which limits the total clockwise travel and the other the total anti-clockwise travel. The two remaining limit switches are arranged to stop the movement of the output shaft at a position mid-way from either the fully closed or fully open positions.

9. On breaking the motor circuit, over-run of the armature is prevented by the magnetic brake. The brake solenoid is energised by the motor supply and holds the spring loaded brake shoe away from the brake disc. As soon as the supply is discontinued, the brake shoe springs back and engages the brake disc, thus limiting the shaft over-run.

## INSTALLATION

10. Installation of the actuator in the aircraft may be anywhere and in any attitude,

subject to an ambient temperature range of  $-65$  to  $+100$  deg. C. For details of individual installations, reference should be made to the appropriate Aircraft handbook.

## SERVICING

11. The servicing of this actuator is as given in A.P.4343, Vol. 1, Sect. 17, Chap. 1, on Western type actuators. If adjustment is necessary the actuator should be returned to the manufacturers.

### Note . . .

*The fine setting grub screws which adjust the micro switches and the cam pins must not be altered in any way at any time.*

12. It is recommended that the actuator be removed for Bay Servicing in accordance with the instructions contained in the relevant Aircraft Servicing Schedule.

### Testing

13. A functional test should be performed by connecting the actuator to a 28 volt d.c. supply and applying opposing loads of zero, 50 lb. in. and 75 lb. in. The maximum current consumption and the time the output shaft takes to complete its full 180 degrees travel, should not exceed the value given below:—

Load (lb. in)	Max. current (amp)	Max. time (sec.)
0	1.85	4.25
50	2.25	4.50
75	2.50	5.25

### Insulation resistance after installation

14. Using a 250 volt insulation resistance tester, measure the insulation resistance between live parts and the frame; it must not be less than 2 megohms.

15. Due to the humidity prevalent in aircraft and at dispersal points, the minimum permissible insulation resistance shall be 50,000 ohms.

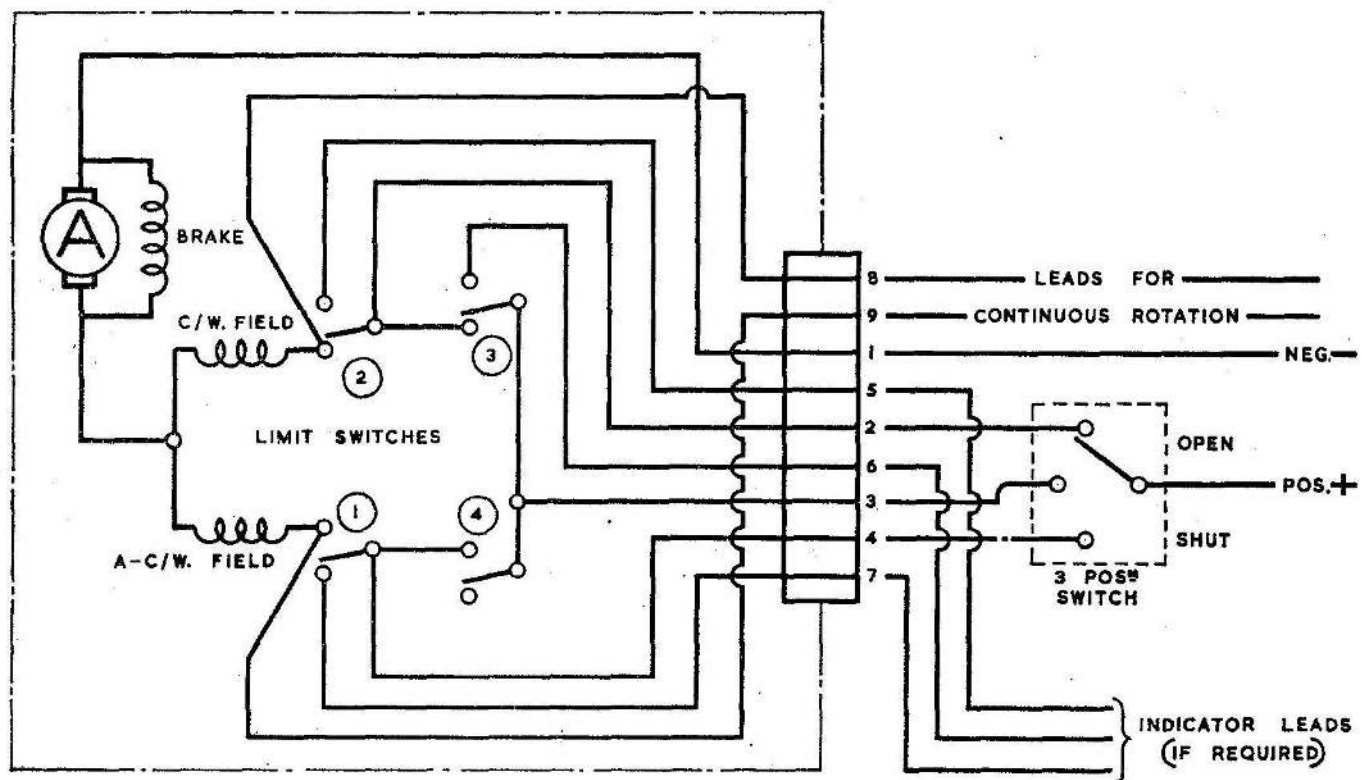

Fig. 3. Circuit diagram

RESTRICTED

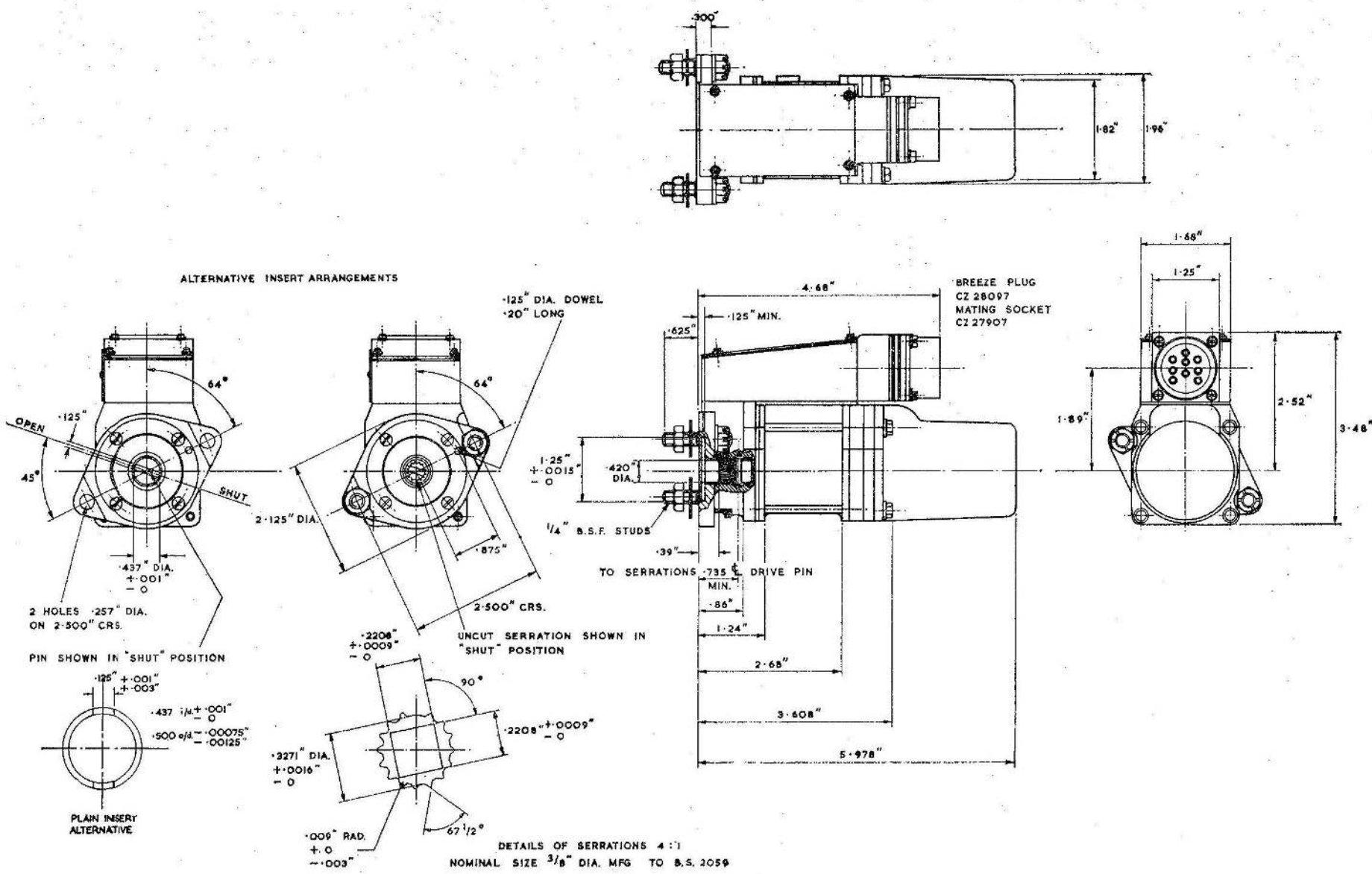

Fig. 2. Installation drawing

This file was downloaded  
from the RTFM Library.  
Link: [www.scottbouch.com/rtfm](http://www.scottbouch.com/rtfm)

Please see site for usage terms,  
and more aircraft documents.

