

## Chapter 1

## FUEL TRANSFER PUMP F.T.P.100 and 101

## LIST OF CONTENTS

	Para.		Para.
<i>Introduction</i> ... ..	1	<i>Removing the supply panel from</i>	
<b>Description</b>		<i>F.T.P.100</i> ... ..	20
<i>General</i> ... ..	4	<i>Pre-installation checks</i> ... ..	21
<i>Pump casing</i> ... ..	6	<i>Starting test</i> ... ..	22
<i>Supply panel (F.T.P.100)</i> ... ..	8	<i>Installation</i> ... ..	23
<i>Pump element</i> ... ..	9	<b>Servicing</b>	
<b>Operation</b> ... ..	15	<i>Routine inspection</i> ... ..	24
<b>Removal and installation</b>		<i>Electrical tests</i> ... ..	26
<i>Removal of the pump element</i> ... ..	18	<i>"No fuel flow" electrical test</i> ... ..	27
		<i>Insulation resistance test</i> ... ..	30

## LIST OF ILLUSTRATIONS

	Fig.
<i>General view of complete pump</i>	
<i>F.T.P.100</i> ... ..	1
<i>Sectional view of complete pump</i>	
<i>F.T.P.100 with F.T.P.101 details</i> ... ..	2
<i>Circuit diagram for pump motor</i> ... ..	3

## LEADING PARTICULARS

Fuel transfer pump consisting of:—

	F.T.P.100	F.T.P.101
<b>Transfer pump element (T.P.E.)</b> ... ..	<b>Ref. No. 5UE/6883</b>	<b>5UE/7885</b>
<b>Transfer pump casing (T.P.C.)</b> ... ..	<b>Ref. No. 5UE/6884</b>	<b>5UE/8536</b>
<b>Motor</b> ... ..	26 volts d.c. flameproof, radio interference suppressed	
<i>Rated voltage</i> ... ..	26V d.c.	
<i>Voltage range</i> ... ..	19 to 26V d.c.	
<i>Fuel delivery pressure</i> ... ..	5.2 lb/in <sup>2</sup>	
<i>No-flow delivery pressure</i> ... ..	9.0 lb/in <sup>2</sup>	
<i>Maximum current consumption (rated flow)</i> ... ..	10.7A + 0.5A	
<i>Current consumption at no-flow</i> ... ..	7.5A (max.)	
<i>Rate of fuel flow</i> ... ..	1460 g.p.h.	
<i>Motor brush grade</i> ... ..	K.C.E.G. 11	
<i>Brush spring tension</i> ... ..	3½ to 5 oz.	
<i>New brush length</i> ... ..	0.375 in	
<i>Minimum permissible brush length</i> ... ..	0.220 in	
<i>Undercut commutator segments</i> ... ..	½ in	
<i>Min permissible commutator diameter</i> ... ..	0.940 in	
<b>Weights</b>		
<i>Complete unit (F.T.P.100 or 101)</i> ... ..	8 lb	
<i>Pumping element (T.E.P.100 or 101)</i> ... ..	3 lb 10 oz	
<i>Pump casing (T.P.C. 100 or 101)</i> ... ..	4 lb 6 oz	

**RESTRICTED**

## Introduction

1. This type of fuel transfer pump forms part of a low pressure fuel system and is normally installed in an aircraft outer wing tank to maintain a supply of fuel from the tank to a collector compartment, usually contained in the wing tip, from which fuel is supplied to other units in the aircraft fuel system.

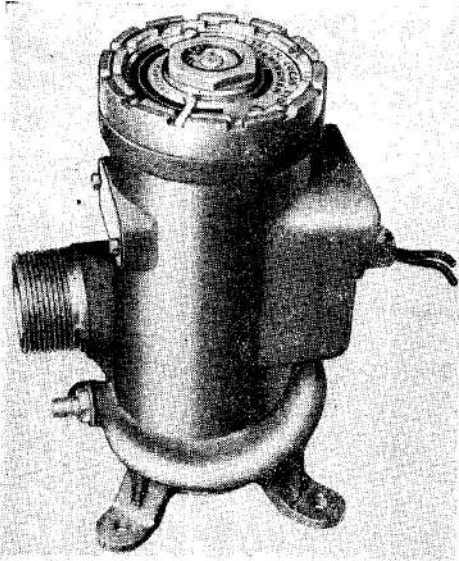

Fig. 1. General view of complete pump F.T.P.100

2. The complete transfer pump comprises two main sub-assemblies:—

(1) The transfer pump element (T.P.E.) consisting of an enclosed d.c. electric motor, an impeller, impeller housing and a seal assembly. Suppressors are fitted to one end of the T.P.E.101 element.

(2) The transfer pump casing (T.P.C.) consisting of an outer casing which incorporates the pump inlet, delivery outlet, and a gland drain connection. The T.P.C.100 casing incorporates an electrical supply panel, and suppressors. A cable union is fitted on the side of the casing to receive the supply cable.

3. The casing is fitted in the aircraft tank and, when once installed, it becomes a permanent fixture which is normally removed only during reconditioning of the

aircraft wing. The pump element can be removed from the casing for examination and servicing; the elements are interchangeable, for each type, to permit renewal and replacement.

## DESCRIPTION

### General

4. The main difference between the F.T.P.100 and the F.T.P.101 types of pump is in the position of the suppressors; the F.T.P.100 has the suppressors within the casing, and the F.T.P.101 has the suppressors on top of the motor for accessibility. The supply panel is omitted and a shrouded impeller has been incorporated in the F.T.P.101.

5. The pump element is located in the pump casing and is retained by a clamp ring. A seal carrier, with a sealing ring, is positioned between the clamp ring and the top end of the motor casing to prevent fuel leakage to the motor connections and suppressors; seal rings are also fitted between the top end of the motor casing and the pump casing, and between the impeller housing and the pump casing to prevent ingress of fuel to the motor. Sealing at the impeller end of the motor shaft is achieved by the provision of a spring loaded carbon face seal accommodated in the impeller housing.

### Pump casing (fig. 2)

6. The pump casing (T.P.C.) is a single casting in which a spiral volute is formed around the pumping chamber. An end cover is secured to the inlet end of the casing to direct fuel to the impeller eye, and an outlet connection is fitted to the volute end. Four mounting feet are cast integral with the casing, at the inlet end, for mounting the unit in the aircraft tank.

7. A housing is formed in the side of the pump casing on the F.T.P.100 to accommodate the electrical supply panel and the radio interference suppressors. The F.T.P.101 has the suppressors mounted on the end of the motor. A union body is fitted to the housing to provide a cable entry, and a connection for electrical conduit. A drain hole is drilled through the pump casing, to which a drain connection is fitted; the purpose of the drain hole is to drain off fuel, that may seep past the

RESTRICTED

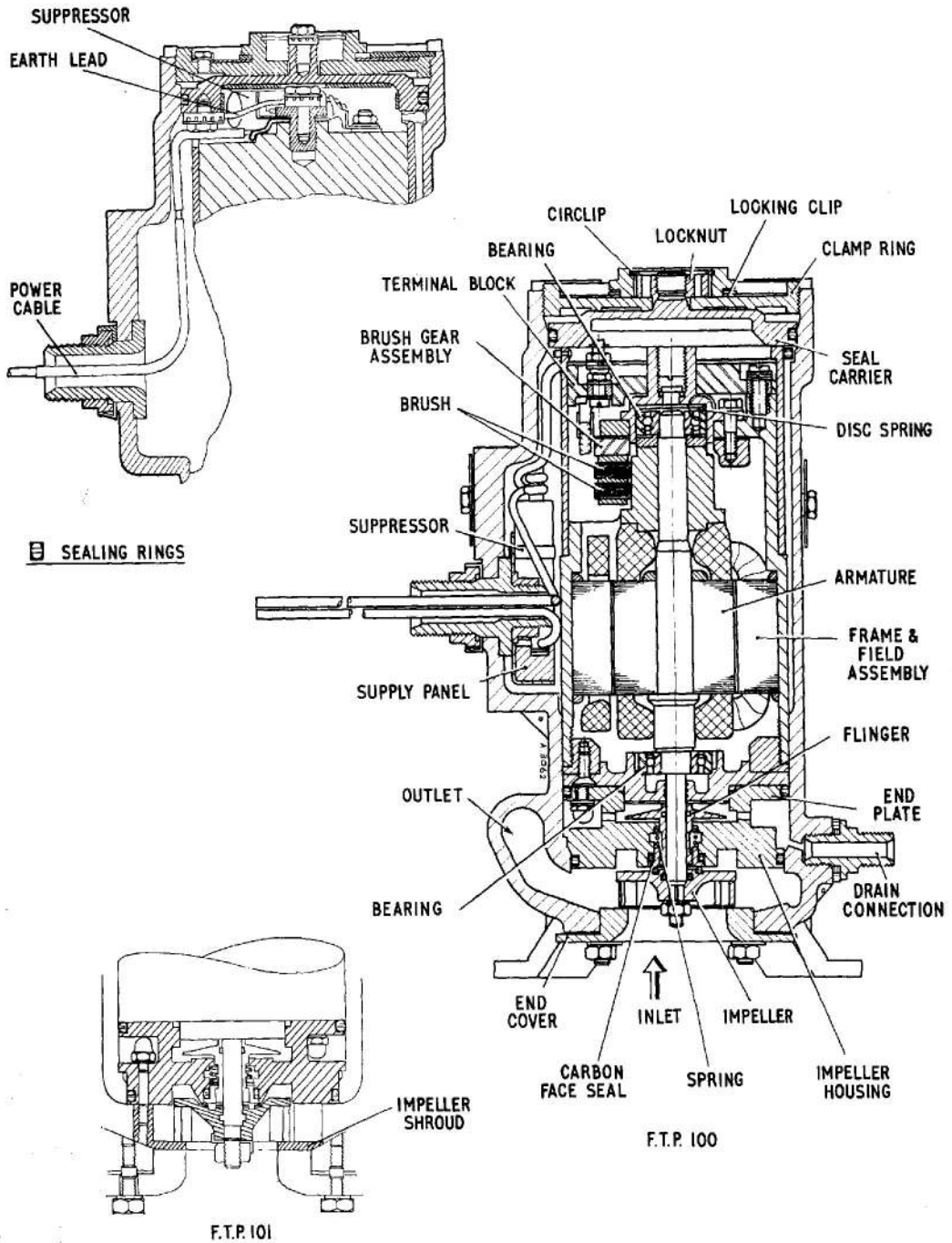

Fig. 2. Sectional view of complete pump F.T.P.100 with F.T.P.101 details.

RESTRICTED

face seal and be discharged by the flinger through holes in the impeller housing, to atmosphere.

#### Supply panel (F.T.P.100)

8. The supply panel is located on the inside of the housing in the pump casing and is locked, from the inside, to the cable union body. After the pump element has been removed from the pump casing, the supply panel can be removed without disturbing the casing or the union body. Two suppressors are mounted on the supply panel, each being a S.T.C. condenser, type 335/LWA/122A/2, having a capacitance of  $0.37F. \pm 30\%$  and a voltage rating, to EL1716, of 30V d.c.

#### Pump element (fig. 2)

9. The motor contained in the pump element is a totally enclosed compound wound, flame-proof motor, which is driven from a 26V d.c. supply. It comprises a frame and field assembly surrounding an armature which is supported at each end in a ball bearing; an open type ball race is used on the F.T.P.100 and a shielded type race is used on the F.T.P.101. The bearings are pre-packed, during manufacture, with high melting point/low freezing point grease, and they cannot be re-lubricated during their period of service.

10. The bearing at the impeller-end of the motor is housed in an end plate which is secured, by countersunk-headed screws, to a ring screwed into the end of the motor body casing. At the commutator-end of the motor, the bearing is housed in a bearing housing which is spigoted into a bore in the casing and is secured by hexagon-headed screws and spring washers. Two disc springs are assembled to the commutator-end bearing, and are located between the bearing and the bearing housing to absorb thrust.

11. At the impeller-end, the armature shaft is extended for direct mounting of a flinger disc and a radial centrifugal type impeller which is retained on a hexagon, formed on the shaft, and is secured by a nut locked with a tabwasher. A carbon face sealing ring is located in a counter-bore in the back face of the impeller, and a spring-loaded face seal abutment ring and sealing rings are positioned between the flinger and the impeller. To prevent fuel leakage along the drive shaft to the

motor, seals are fitted into the bores of both impeller and flinger.

12. The impeller housing is located by a dowel and is secured to studs, on the motor end plate, by three wire-locked dome nuts and washers. A chamber is formed, between the impeller housing and the motor end-plate, in which the flinger disc rotates, and radial holes are drilled through the housing to disperse any face seal fuel seepage that is discharged by the flinger (para. 16).

13. At the commutator-end of the motor casing, the brush gear assembly is secured to the bearing housing, and each brush contains a pair of carbon brushes from which leads are connected to a terminal block, located in the end of the motor casing and secured to the frame by cheese-headed screws and spring washers.

14. When fitted to the pump casing, the motor casing is retained by the clamp ring and seal carrier which prevents fuel leakage to the terminal block and motor (para. 5). After the seal carrier has been fitted, it is locked by a locknut and circlip, and the clamp ring is locked in the casing by a locking clip.

### OPERATION

15. The extreme range of operating temperatures for the pump is 115 deg. C. to -50 deg. C. The higher temperature extremity is in air only, and frequent contact of the carbon face seal with fuel is essential to avoid damage to the seal assembly. The maximum operating temperature for a pump immersed in fuel is 80 deg. C.

16. Fuel enters the eye of the impeller through the inlet formed by the end cover on the pump casing. The centrifugal action of the impeller, pumps the fuel to the spiral volute in the pump casing from which is directed through an outlet connection to the delivery line.

17. Any fuel which may seep past the seal retainer, along the drive shaft, is picked up by the rotating flinger and discharged through the radial drillings in the impeller housing to an annular space formed on the outside of the housing, to

**RESTRICTED**

drain away through the drain hole in the pump casing and the drain connection.

## REMOVAL AND INSTALLATION

### Removal of the pump element

18. Before attempting to remove the pumping element (T.P.E.) from the installed casing (T.P.C.) ensure that all fuel has been drained from the aircraft tank, and disconnect the electrical supply to the pump motor. The precise method of removing the element from the casing will be detailed in the relevant Aircraft Handbook. In general, this entails the removal of:—

- (1) Access panels in the wing and tank.
- (2) The circlip locking the central locknut, and the locknut, using a peg spanner T.324206.
- (3) The locking clip, locking the clamp ring to the casing, and the clamp ring.

19. It is important to clean out any fuel which may have penetrated into the cavity formed between the clamp ring and the seal carrier to prevent any fuel, that may be present, from entering the motor casing when the seal carrier is removed. Replace the clamp ring in the pump casing, screwing it in by hand pressure only, replace the locknut, and proceed as follows:—

- (1) Hold the locknut to prevent it from turning, then unscrew the clamp ring. The seal carrier will then be removed together with the clamp ring.
- (2) Unscrew the terminal nuts on the motor terminal block, and disconnect the cables. On F.T.P.101, remove the suppressors.
- (3) Using an extractor T.324208, withdraw the pump element from the pump casing.
- (4) Cover the end of the pump casing to prevent ingress of foreign matter.

### Removing the supply panel from F.T.P.100

20. If the supply panel is to be removed

for any reason, it can be removed from a pump casing "in situ" as follows:—

- (1) Remove the nuts and shakeproof washers, connecting the distribution cables to the supply panel, and disconnect the cables; replace the nuts and washers to prevent loss.
- (2) Bend back the tab of the lock-washer which locks the union body locknut, on the inside of the pump casing.
- (3) Using a torque spanner adapter T.344604, remove the locknut.
- (4) Remove the supply panel assembly from the inside of the pump casing, leaving the main power cable "in situ."

### Pre-installation checks

21. The installation of a new pump element should be preceded by the following checks:—

- (1) Ensure that the element has not been in storage longer than the specified maximum period.
- (2) Examine the exterior of the element, ensure that it is scrupulously clean and check for damage, security of locking devices and signs of corrosion. Blend out any slight areas of corrosion and apply a protective finish of ALACROM. Reject the pump element if corrosion is more than slight.
- (3) Remove the transit plugs, blanking caps and any protective material used for storage purposes.
- (4) Apply a starting test to the element.

### Starting test

22. (1) Immerse the inlet end of the pump in fuel, for a few seconds, to a depth of  $\frac{3}{4}$  inch, i.e., level with the lower of the two sealing rings to lubricate the carbon face seal.
- (2) Connect the motor cables to a 26V d.c. supply, and switch on the supply. The pump should start immediately.
- (3) Switch the supply on and off several times and repeat the test.

**RESTRICTED**

## Installation

23. Installation of the element and supply panel (if fitted) to the pump casing will be covered in detail in the relevant Aircraft Handbook.

Generally it will be the reverse of the operations detailed for removal and should include the following :—

- (1) Fit new sealing rings to the two external grooves on the impeller housing, to the seal carrier and the commutator end of the motor casing.
- (2) Smear the sealing rings lightly with petroleum jelly before inserting the element into the pump casing.
- (3) Using the assembly guide T.369936 to prevent cable damage and to facilitate installation, insert the element into the casing.
- (4) Ensure that the ends of the supply leads do not become trapped as the element is pressed into the casing, and ensure that, when fully entered, the impeller housing is located on the seating in the casing.
- (5) Connect the supply leads to the motor terminals on the terminal block, and attach the suppressor to the motor (F.T.P.101).
- (6) When fitting a clamp ring, a spanner with a maximum leverage of six inches should be used to prevent over tightening and possible internal damage to the unit.

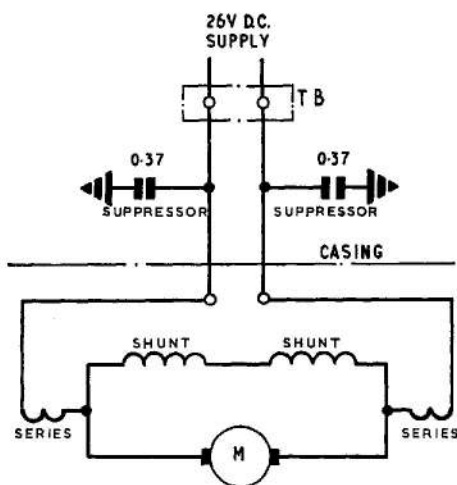

Fig. 3. Circuit diagram for pump motor

## SERVICING

### Routine inspection

24. At routine inspections the following procedure should be adopted :—

- (1) Examine all pipe connections and locking devices.
- (2) Test the pump as detailed in para. 26 to 30. If the pump does not comply with the performance data, the pump element must be removed and a new or reconditioned element must be fitted. No "in situ" maintenance is possible.

25. At the periods stipulated in the appropriate Servicing Schedules, the pump element must be removed and a new or reconditioned element must be fitted. Faulty or time expired pump elements must be returned to a Maintenance Unit or to the manufacturer for reconditioning. It is not possible to renew carbon brushes or bearings without partially dismantling the unit, and after re-assembling, the pump must be tested fully on a test rig; these tests can only be carried out at a suitably equipped maintenance unit, or by the manufacturers.

### Electrical tests

26. A routine electrical test, in accordance with the appropriate Servicing Schedule should be made to ascertain that the motor is functioning satisfactorily. This test must be made with the motor on load (i.e. with the pump installed and immersed in fuel). The pump element must be renewed if there is any indication of erratic performance, excessive current consumption or unusual running features.

### "No fuel flow" electrical test

27. Refer to the relevant Aircraft Handbook and ascertain the position of the pump test socket and switches, then proceed as follows :—

- (1) Close all the fuel cocks between the pump and the engine, and between the pump and collector box to ensure that there is no fuel flow.
- (2) Connect a suitable portable ammeter to the socket on the test panel.

### Note . . .

When using a "clip on" type of ammeter, open and close the tongs smartly, prior to use, to reduce hysteresis errors.

RESTRICTED

(3) Switch on the pump by operating the switch on the test panel (not the normal fuel pump switch). Allow the pump to run for a period of not less than half-a-minute, and record the ammeter readings during this period. Ensure that the voltage stated on the test schedule is registered at the motor terminals.

28. The readings obtained will indicate the condition of the pumping element as follows :—

- (1) A steady reading not in excess of 7.5A indicates that the pump is operating satisfactorily.
- (2) A reading in excess of 7.5A indicates a motor fault, a restriction in the fuel circulation, or a rise in torque loading due to the obstruction of moving parts.
- (3) A fluctuating reading indicates faulty brushes, unsatisfactory brush

contact, faulty commutator or partial binding of bearings or rotating parts.

(4) A zero reading indicates an open circuit, and is consistent with a blown fuse, defective switch or wiring, or a complete failure of the motor.

29. After completing the "No fuel flow" test, release the test switch, and disconnect the ammeter from the test socket.

#### Insulation resistance test

30. Using a 250 volt constant pressure insulation resistance tester, measure the insulating resistance between the supply cables and earth. On a pump that has been in service, and possibly been subjected to humidity through aircraft standing in the open, a minimum insulation resistance of 50,000 ohms is permissible. On new or reconditioned pump elements, the resistance should be measured between the motor terminals and the motor frame and should be above 2 megohms.

**RESTRICTED**

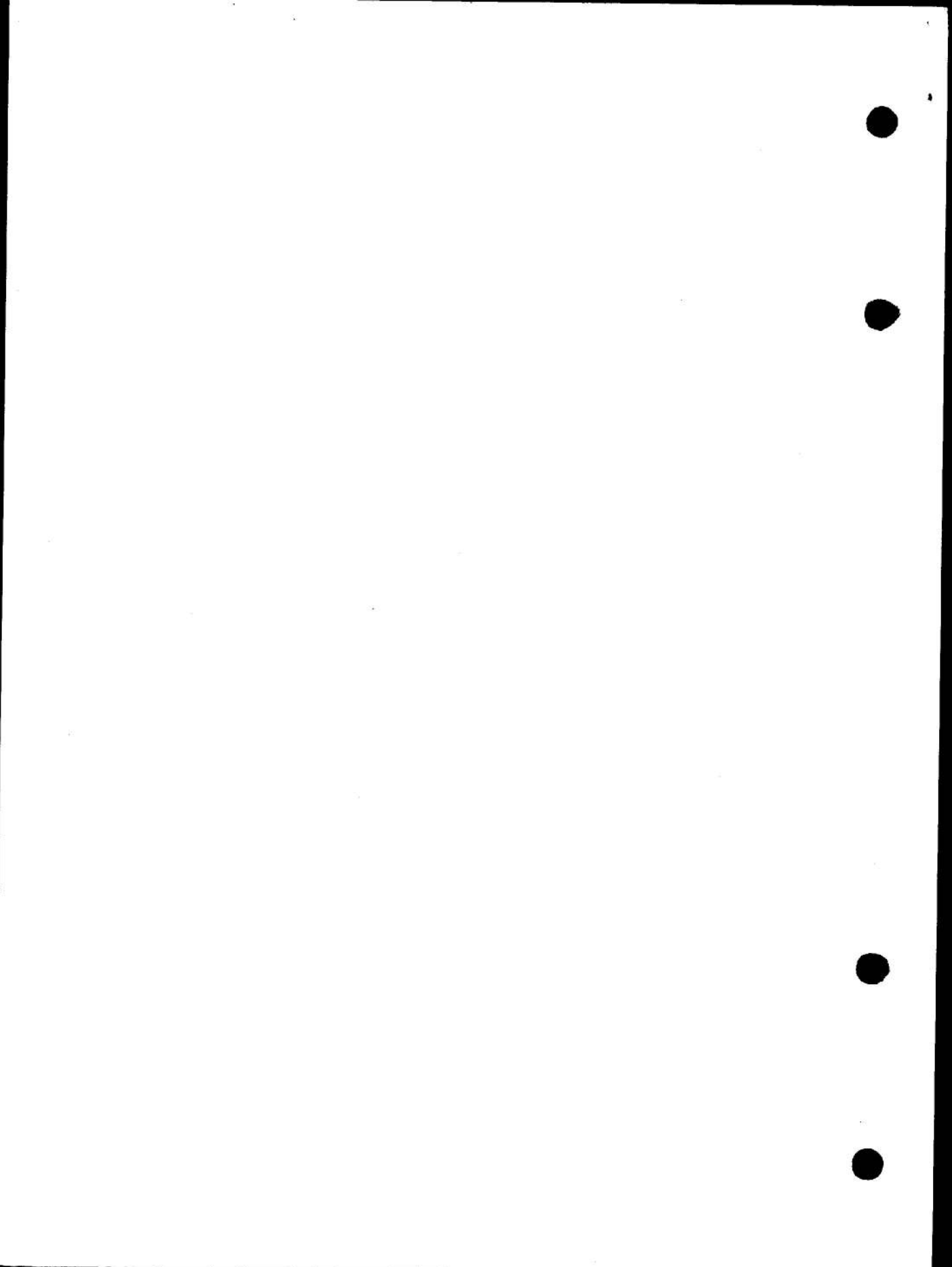

This file was downloaded  
from the RTFM Library.

Link: [www.scottbouch.com/rtfm](http://www.scottbouch.com/rtfm)

Please see site for usage terms,  
and more aircraft documents.

