

## Chapter 2

**PUMP, FUEL, TYPE PDC.1001, MK. 1, 2 AND 3**  
**WITH CASING, TYPE PDC.1002 MK. 1, 2 AND 3**

## LIST OF CONTENTS

	<i>Para.</i>		<i>Para.</i>
<i>Introduction</i> ... ..	1	<b>Servicing</b>	
<b>Description</b>		<i>Routine inspection</i> ... ..	11
<i>General</i> ... ..	3	<i>Electrical test</i> ... ..	13
<i>Motor unit</i> ... ..	4	<i>'No fuel flow' electrical test</i> ... ..	14
<i>Casing</i> ... ..	6	<i>Operational test</i> ... ..	17
<b>Operation</b> ... ..	7	<i>Gland leakage</i> ... ..	18
<b>Removal and installation</b> ... ..	8	<i>Insulation resistance test</i> ... ..	19

## LIST OF ILLUSTRATIONS

	<i>Fig.</i>		<i>Fig.</i>
<i>General view of Type PDC.1001, Mk. 1 fuel pump and casing Type PDC.1002, Mk. 1</i> ... ..	1	<i>Circuit diagram</i> ... ..	3
<i>Sectional view of Type PDC.1001, Mk. 1 fuel pump and casing Type PDC.1002, Mk. 1</i> ... ..	2	<i>Sectional view of Type PDC.1001, Mk. 2 and Mk. 3 fuel pump</i> ... ..	4
		<i>'No fuel flow' electrical test graph</i> ... ..	5

## LIST OF APPENDICES

	<i>App.</i>
<i>Pumps, fuel Type PDC.1001, Mk. 1, 2 and 3, fitted to casings Type PDC.1002, Mk. 1, 2 and 3</i> ... ..	1

**RESTRICTED**

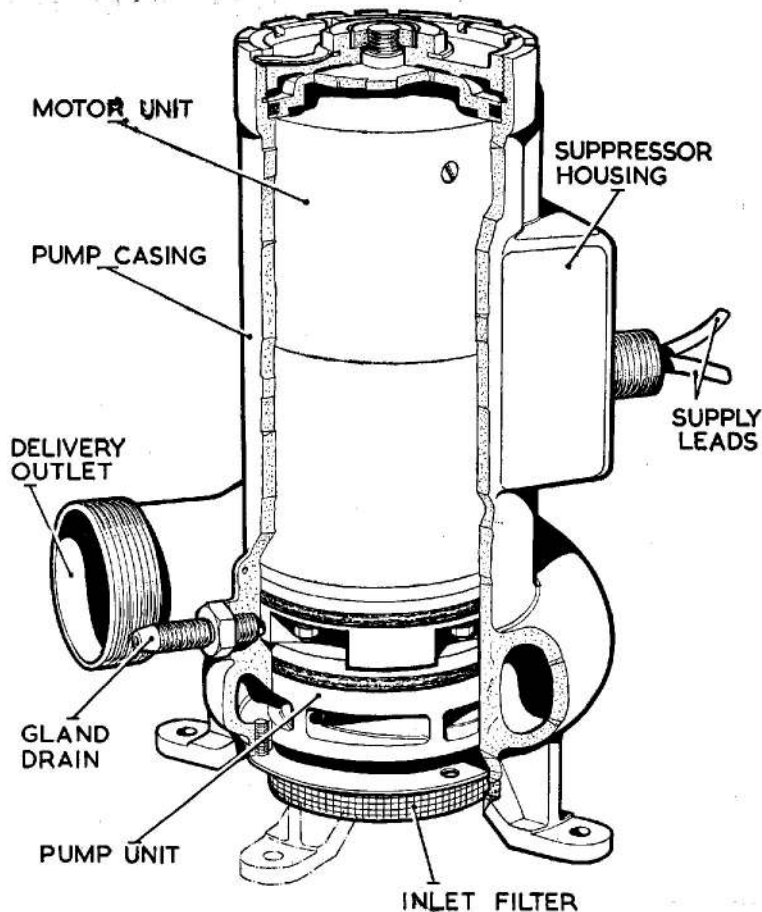

Fig. 1. General view of Type PDC.1001 Mk.1 fuel pump and casing Type PDC.1002 Mk.1

### Introduction

1. The Type PDC.1001 pumps are designed to supply fuel under pressure to the aircraft fuel supply line at all conditions of fuel de-aeration, high altitude vapour formation and extremes of temperature. Leading particulars of these pumps, are included in appendices to this chapter.

2. The complete pump comprises two separate sub-assemblies: (1) the motor unit with impeller assembly (PDC.1001) and (2) the outer casing (PDC.1002) incorporating the pump delivery outlet, the gland drain, the inlet filter and the radio interference suppression assembly. This casing can only be removed from the aircraft during a complete wing overhaul; the pump unit can be withdrawn from the casing when required, through a top surface tank panel.

### DESCRIPTION

#### General

3. A general and sectional view of a typical pump are illustrated in Fig. 1 and 2. The unit comprises mainly a d.c. motor unit with extended armature shaft driving a centrifugal high altitude type impeller. The motor unit is enclosed in the casing assembly and fuel is prevented from entering it by seal rings at each end of the unit together with a mechanical seal on the shaft.

#### Motor unit

4. The pump is driven by a motor operated from a 26 volts d.c. supply. The extended armature shaft is supported at each end by ball bearings and carries the impeller together with the mechanical seal referred to in para. 3. Rotation is anti-clockwise when viewed from the commutator end. The

RESTRICTED

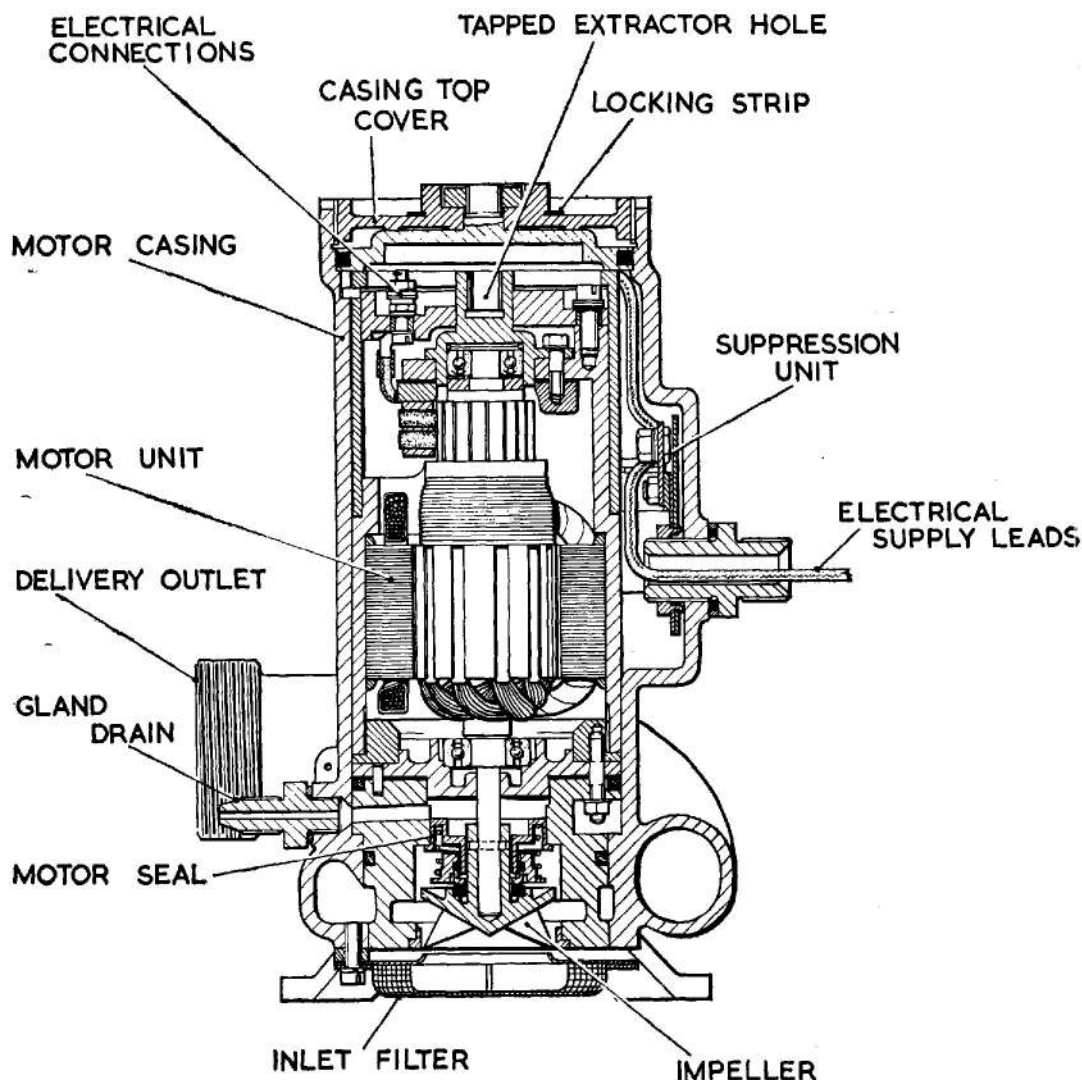

Fig. 2. Sectional view of Type PDC.1001, Mk.1 fuel pump and casing Type PDC.1002, Mk.1

electrical supply is connected to two terminal studs on the top of the motor unit and radio interference suppressors housed within the casing, are included in the circuit.

5. The rotating carbon member of the mechanical seal is recessed into the upper surface of the impeller assembly. Any slight leakage past this seal is drained through channels in the diffuser and casing castings, from which it is piped to atmosphere.

#### Casing

6. The pump unit casing is bolted in position through four fixing feet and carries the delivery outlet, the gland drain and the electrical conduit connections. Access to the pump/motor assembly is through a screwed end cap which is removable through a panel in the top of the fuel tank.

#### OPERATION

7. Fuel from the tank enters the pump

**RESTRICTED**

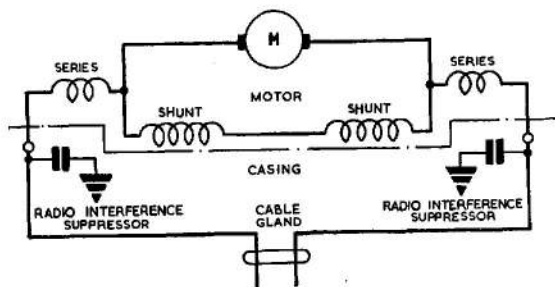

Fig. 3. Circuit diagram

through the wire mesh filter into the eye of an impeller driven by the extended armature shaft. From here it is forced through a diffuser channel into the casing fuel outlet and finally into the delivery line.

### REMOVAL AND INSTALLATION

8. Before attempting to remove a pump ensure that the tank has been drained of fuel and that the electrical supply to the pump has been disconnected. The precise method of removing the pump will be found detailed in the appropriate Aircraft Handbook. In general removal will comprise the following operations: (1) the detachment of access panels in wing and fuel tank, (2) the releasing of the locking strip on the top of the pump, (3) the unscrewing and removal of the casing top cover, (4) the release of the electrical connections to the two terminals and (5) the withdrawing of the motor unit (using a bar screwed  $\frac{3}{8}$  in. B.S.F. in the tapped hole in the motor end bearing housing).

9. Installation of a new pump unit (PDC. 1001) should be preceded by the following checks:—

- (1) Ensure that the unit has not been stored for longer than the specified maximum period (i.e. 12 months in original packing or 3 years when special packing has been provided).
- (2) Inspect the exterior of the pump for evidence of damage. Check for any signs of corrosion and apply a protective finish (e.g. chromic acid solution) to the unprotected area.
- (3) Ensure that the pump unit is scrupulously clean externally.
- (4) It is advisable to make a starting check on the pump unit before installation. To do this the carbon shaft bearing should be first lubricated with a

small quantity of fuel, taking care that none enters the gland drain channel. Apply a 26 volts d.c. supply through the end terminals. The pump should start immediately. Switch off the supply and repeat the test several times. If the pump fails to start immediately it should be returned to an overhaul base for further serviceability testing using approved equipment.

The above pre-installation instructions apply to all aircraft installations of these pumps. For detailed procedure covering installation in a particular aircraft refer to the appropriate Aircraft Handbook.

10. As a general example installation in the aircraft will comprise the following operations:—

- (1) Ensure that new seal rings are fitted in the two grooved housings of the diffuser casting. Smear each with a trace of an approved lubricant.
- (2) Screw a bar threaded  $\frac{3}{8}$  in. B.S.F. into the end of the upper bearing housing central embossment. Carefully lower the motor unit into the casing assembly ensuring that (a) the ends of the supply leads are outside the casing (clearance is provided) and (b) that the pump unit is positively located by the diffuser casting and motor end cover dowels.
- (3) Connect the supply leads to the pump unit terminals.
- (4) Fit a new seal ring in the rim groove of the top cover and screw the cover into position. Tighten using a  $\frac{7}{8}$  in. B.S.F. box spanner on the central cover boss. Fit the locking spring to top cover.
- (5) Replace the tank and wing access panels.

### SERVICING

#### Routine inspection

11. At routine inspections test the pump as detailed in para. 13 to 19. If the pump is found to be defective it must be removed as detailed (para. 8) and a new or reconditioned pump fitted. No in-situ maintenance is possible.

12. At the periods laid down in the appropriate servicing schedules, all pumps are to be replaced by new or reconditioned pumps drawn from stores. Faulty pumps must be

RESTRICTED

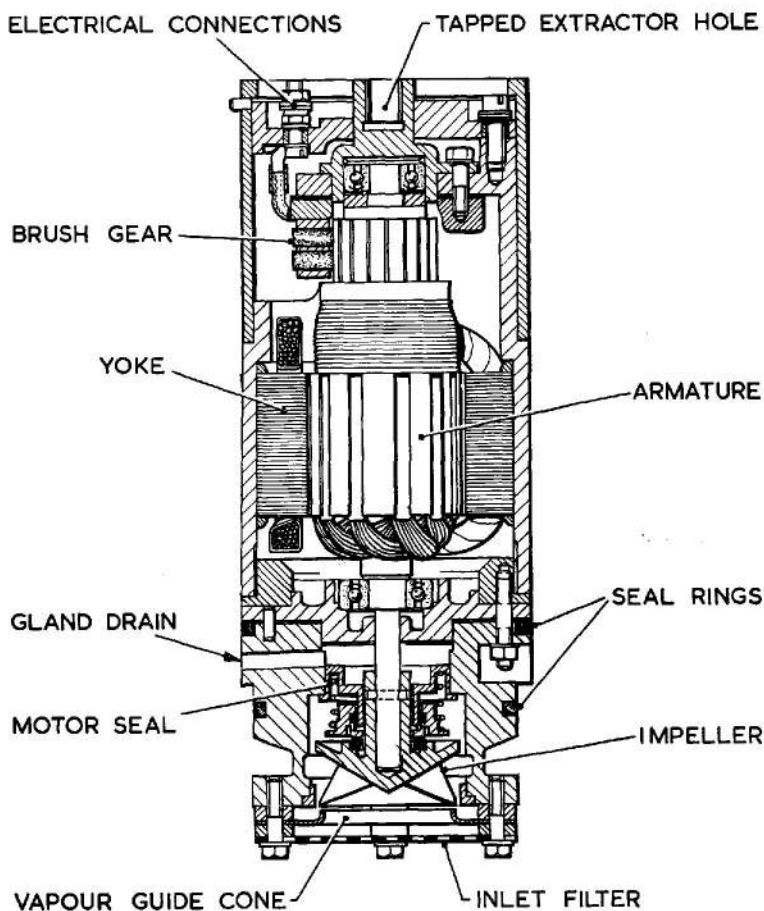

**Fig. 4. Sectional view of type P.D.C.1001 Mk. 2 and Mk. 3 fuel pump**

returned to a Maintenance Unit, or to the manufacturer for repair.

#### Electrical test

13. A periodic electrical check in accordance with the appropriate Servicing Schedule should be made to ascertain that the motor is functioning satisfactorily. The pump must be replaced by a new or reconditioned pump if there is any indication of erratic performance such as excessive current consumption. These tests should only be made with the motor on load i.e. immersed in and pumping fuel.

#### 'No fuel flow' electrical test

14. Before applying the electrical test at 'no fuel flow' ascertain the position of the aircraft pump test socket and switches, by

reference to the relevant Aircraft Handbook. When this has been done proceed as follows:—

- (1) Close all fuel cocks between pumps and engines to ensure that no fuel can flow.
- (2) Connect a suitable portable d.c. ammeter to the test socket on the test panel.
- (3) Switch on the pump by depressing the test push-switch on the test panel, and note the reading of the ammeter for a period of not less than half-a-minute.

15. Interpret readings obtained as follows:—

- (1) A steady reading not exceeding that indicated by the graph (Fig. 5) for the measured applied voltage, indicates

**RESTRICTED**

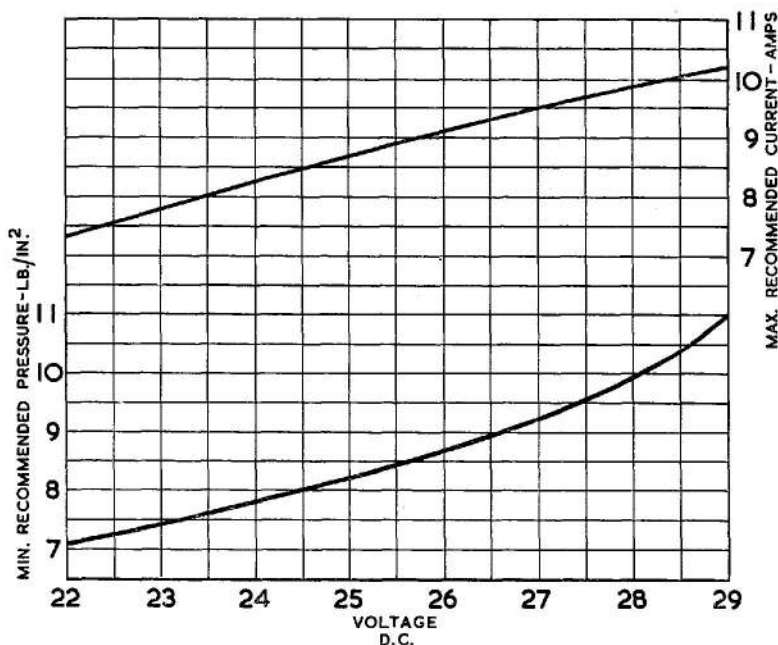

Fig. 5. "No fuel flow" electrical test graph

that the motor is functioning satisfactorily.

**Note . . .**

*The graph (fig. 5) is provided as a guide to pump performance under no-flow conditions; the figures derived from it are not to be interpreted as forming a part of the approved Acceptance Test Specification for the pump.*

- (2) Current consumption in excess of the graph reading indicates either a faulty motor unit, a rise in torque loading due to the obstruction of the moving parts, or a restriction of the fuel flow.
- (3) A fluctuating reading indicates faulty brushes or commutator or that the bearings or other rotating parts are binding.
- (4) A zero reading indicates an open circuit and is consistent with a blown fuse, defective switch, faulty wiring or in extreme cases, a complete motor failure.

16. When the above checks have been completed, release the test push switch on the test panel and disconnect the ammeter from the test socket.

**Operational test**

17. Subject to the electrical tests being satisfactory, the pump should be tested for

proof of performance, and checked against the given figures quoted in the appropriate appendix to this chapter.

Failure to obtain the quoted pressures and rate of fuel delivery could be caused by a faulty motor unit, damaged impeller, or an incorrect loading of the pump unit gland unit. The pump unit should be removed from the casing to ascertain the cause of failure.

**Gland leakage**

18. During the above tests an examination should be made of the gland drain exit for fuel leakage. The leakage must not exceed two drops per minute while the pump is running or one drop per minute while stationary. Any leakage in excess of these figures will necessitate removal of the pump.

**Insulation resistance test**

19. Using a 250-volt constant pressure insulation resistance tester measure the insulation resistance between live parts and the frame. The insulation resistance tester used for this check should be fitted with an electrical socket to suit the pump electrical connection. When a new pump is installed the insulation resistance should not be less than 2 megohms. After installation for operational service, due to the humidity prevalent in aircraft at dispersal points, the minimum insulation resistance permissible is 50,000 ohms.

## Appendix 1

### PUMPS, FUEL, TYPE PDC.1001 MK. 1, 2 AND 3

### FITTED TO CASINGS TYPE PDC.1002 MK. 1, 2 AND 3

Pump, fuel, Type PDC.1001 Mk.1	...	...	Ref. No. 5UE/6492
Casing, fuel pump, Type PDC.1002 Mk.1	...	...	Ref. No. 5UE/6525
Pump, fuel, Type PDC.1001 Mk.2	...	...	Ref. No. 5UE/
Casing, fuel pump, Type PDC.1002 Mk.2	...	...	Ref. No. 5UE/
Pump, fuel, Type PDC.1001 Mk.3	...	...	Ref. No. 5UE/7597
Casing, fuel pump, Type PDC.1002 Mk.3	...	...	Ref. No. 5UE/7641
Voltage limits	...	...	22·0/29·0V d.c.
Rated voltage	...	...	26·0V d.c.
Rated output at 26V d.c.	...	...	1000 gal./hr.
Delivery pressure at rated output/voltage	...	...	2·5 lb./in <sup>2</sup> . minimum
Maximum current consumption at rated output/voltage	...	...	7·25A (Mk. 1)
			7·5A (Mk. 2 and 3)
Maximum no-flow delivery pressure at rated voltage	...	...	27·0 lb. in <sup>2</sup> .
Minimum no-flow delivery pressure	...	...	See Fig. 4, basic chapter
Electrical connection	...	...	Flying leads
Delivery outlet (in casing)	...	...	1½ in. B.S.P. (male)
Gland drain	...	...	AGS.1105 Mk. A adapter
Electrical conduit connection	...	...	¾ in. B.S.P. (male)
Weight of unit (approximately)	...	...	4·0 lb.—PDC.1001
			3·75 lb.—PDC.1002
			7·75 lb.—Total weight

#### Introduction

1. Type PDC.1001 fuel pumps are designed for fitting to the type PDC.1002 casing which forms a semi-permanent fitting in the aircraft fuel tank. The assembly is similar to that described and illustrated in the main chapter.

#### Type differentiation

2. Basic differences between the various marks of PDC.1001/1002 pumps and casings covered by this appendix are as follows:—

PDC.1001 Mk.1	Initial production design.
PDC.1001 Mk.2	Basically as Mk.1 pump but incorporates a vapour guide cone and a base filter.
PDC.1001 Mk.3	Generally similar to Mk.2 pump.

but incorporates a new O-ring seal. Motor length revised to improve seal conditions.

#### Pump casings:

PDC.1002 Mk.1	Initial production design.
PDC.1002 Mk.2	Basically as Mk.1 casing but the vapour guide cone and filter are not incorporated in this assembly.
PDC.1002 Mk.3	Generally similar to Mk.2 casing but suppressor assembly redesigned to eliminate creepage, mis-assembly and vibration in-situ.

**RESTRICTED**

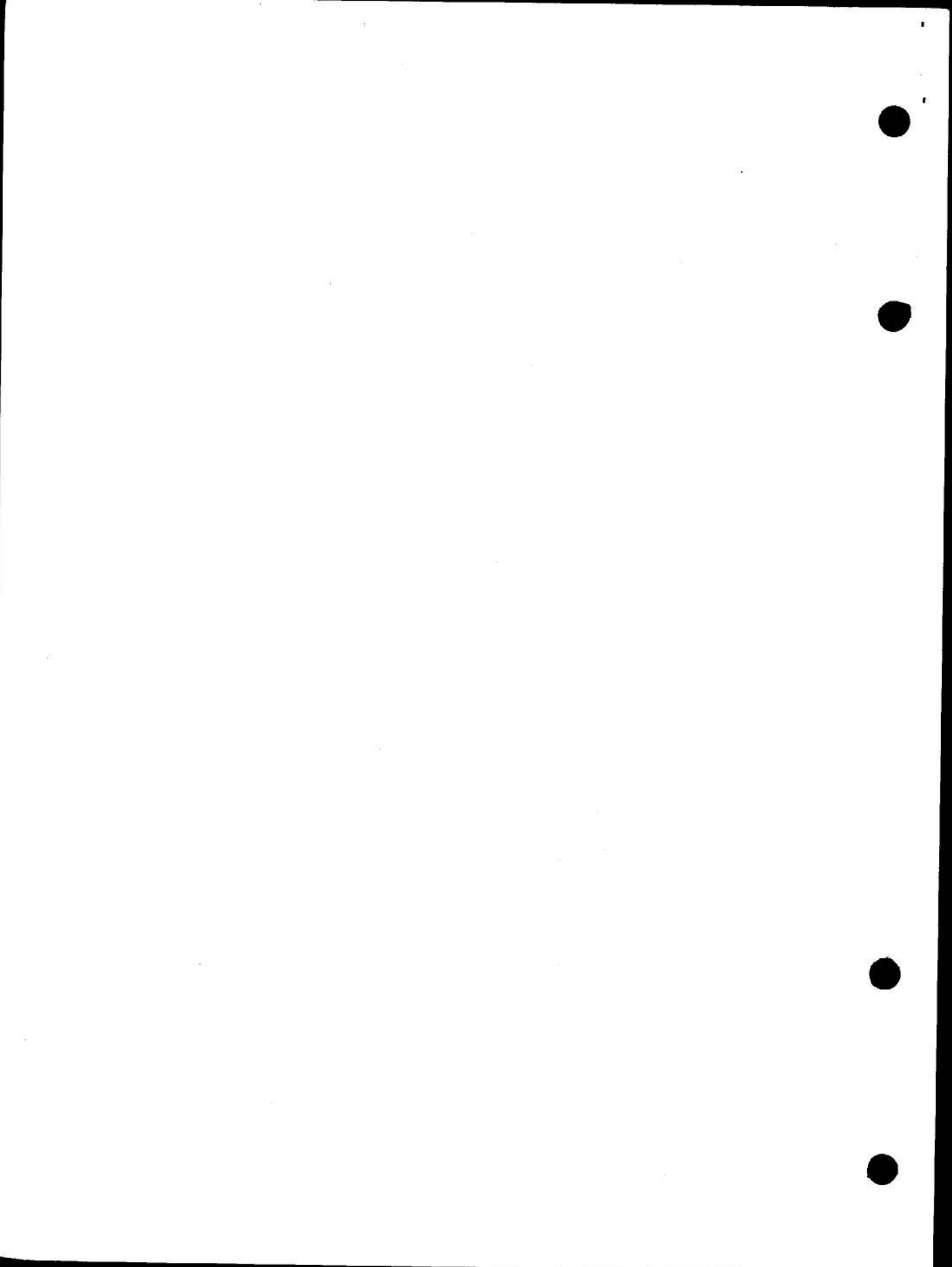



This file was downloaded from the RTFM Library.

Link: [www.scottbouch.com/rtfm](http://www.scottbouch.com/rtfm)

Please see site for usage terms, and more aircraft documents.

