

## Chapter 20

## PUMP, FUEL, B.P.14 and B.P.14/RS SERIES

## LIST OF CONTENTS

	<i>Para</i>		<i>Para.</i>
<i>Introduction</i> ... ..	1	<i>Pre-installation checks</i> ... ..	16
<b>Description</b>		<i>Installation</i> ... ..	18
<i>General</i> ... ..	3	<b>Servicing</b>	
<i>Pump body casting assembly</i> ... ..	5	<i>Routine inspection</i> ... ..	20
<i>Motor Unit</i> ... ..	9	<i>Electrical test</i> ... ..	22
<i>Filter</i> ... ..	11	<i>'No-fuel flow' test</i> ... ..	23
<b>Operation</b> ... ..	12	<i>Gland leakage</i> ... ..	26
<b>Removal and Installation</b>		<i>Insulation resistance test</i> ... ..	27
<i>Removal</i> ... ..	15	<i>Operational test</i> ... ..	28

## LIST OF ILLUSTRATIONS

	<i>Fig.</i>		<i>Fig.</i>
<i>External view of typical B.P.14/RS fuel pump</i> ... ..	1	<i>Section through the delivery duct...</i> ... ..	3
<i>Sectional view of B.P.14/RS Mk. 3 fuel pump</i> ... ..	2	<i>'No-fuel flow' test graph</i> ... ..	4

## LIST OF TABLES

	<i>Table</i>
<i>Faults, possible causes and rectification...</i>	1

## LIST OF APPENDICES

	<i>App.</i>		<i>App.</i>
<i>Pumps, fuel, Type B.P.14 Mk. 2, 2A, 3 and 3A</i> ... ..	1	<i>Pumps, fuel, Type B.P.14/RS Mk. 2, 2A, 3 and 3A</i> ... ..	2

RESTRICTED

## Introduction

1. Type B.P.14 and B.P.14/RS series fuel booster pumps are small electrically driven, self-contained units designed to supply fuel under pressure to the aircraft main fuel supply line, or alternatively to transfer fuel from auxiliary to main tanks. Rated operating voltage is 24V d.c.

2. Type B.P.14/RS pumps are fitted with built-in radio interference suppressors but are otherwise similar in construction and performance to the B.P.14. The unit is installed in the base of the aircraft fuel tank or in a collector box or sump, with the enclosed electric motor and the pump inlet submerged in the fuel. Details of the differences between the mark numbers of each type, together with the Leading Particulars are given in the appendices to this chapter.

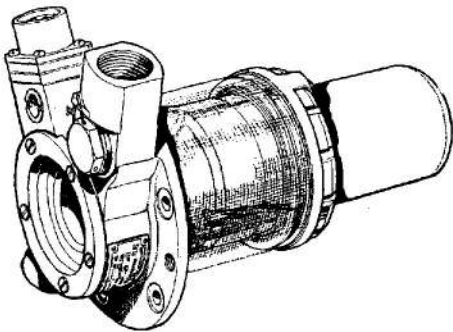

Fig. 1. External view of typical B.P.14/RS fuel pump

## DESCRIPTION

### General

3. A typical B.P.14/RS fuel pump is shown in Fig. 2 and 3. This basic arrangement is common to all B.P.14 and B.P.14/RS pumps except for the exclusion of the radio interference suppressors from the upper end on the motor unit of all B.P.14 pumps, and differences in components used for preventing fuel ingress into the motor unit on various mark numbers of each type. Details are given in the appendices to this chapter.

4. The basic pump design is a self-contained unit comprising two main sub-assemblies:—  
(1) The pump body casting assembly.  
(2) The motor unit with casing.

### Pump body casting assembly

5. The pump body casting is provided with a circular flange for attachment of the pump

assembly to the fuel tank stud ring, and also carries the fuel delivery outlet, gland drain and electrical supply connections. When installed, this part of the assembly is the only portion of the pump unit projecting below the fuel tank. The casting has a circular cavity in its base which, when the diffuser plug is in position, forms the impeller chamber.

6. A drain plug is fitted in the delivery duct, together with a by-pass flap valve which enables fuel to be drawn directly from the tank by the engine driven fuel pump when the booster pump is idle. This valve is normally held closed by pump delivery pressure.

7. The upper part of the pump body casting is machined internally to locate the motor unit, and threaded externally to receive the bezel ring by which the motor unit is clamped and sealed in the casting. Two cored pillars separate the upper and lower parts of the pump body casting. One pillar provides a conduit for the electrical supply leads to the motor unit and also serves as a motor breather, while the other is used to drain off fuel, which may seep past the main gland, to the gland drain outlet on the pump base. The portways between these pillars form the fuel inlet to the centrifugal impeller system fitted to the extended armature shaft of the motor unit.

8. The metallic bellows type gland, preventing fuel ingress into the motor unit is housed in the pump body casting. The polished face of the bellows gland is in contact with a lapped carbon insert in a vapour assister component which is fitted to the extended armature shaft of the motor unit, and effects the seal.

### Motor unit

9. The motor unit is a flameproof, two pole compound-wound machine, suitable for use on a supply voltage of 22.0/28.8V d.c. Rated operating voltage is 24V d.c. Brush gear is of unit construction to facilitate assembly, and contains four brushes, two on each side in pairs. The armature shaft is supported by two ball bearings, both of which are pre-packed during manufacture with an anti-freeze/high melting point grease and cannot be re-lubricated. The upper bearing is retained in a steel sleeve and the inner race of the lower bearing is locked to the armature shaft by a screwed ring which incorporates a 'thrower' to fling off any fuel which may seep past the main gland.

RESTRICTED

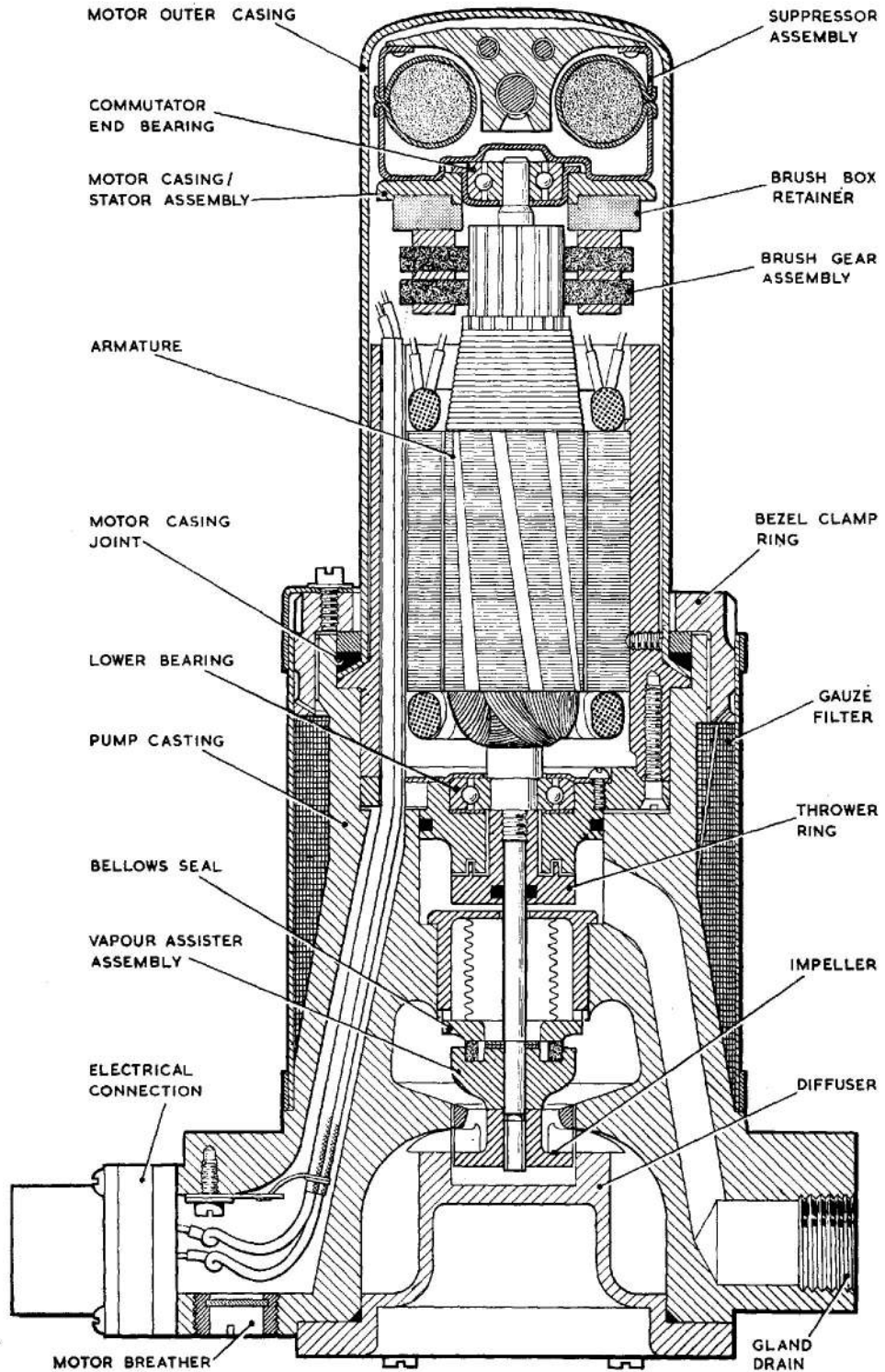

Fig. 2. Sectional view of B.P.14/RS Mk. 3 fuel pump

**RESTRICTED**

The design of thrower nut fitted varies according to the mark of pump being examined (refer to appendices).

10. Capacitors are fitted to the upper end of the motor casing of B.P.14/RS pumps, but not to B.P.14 pumps (para. 3) to suppress radio interference. The complete motor unit locates in a recess in the pump body casting and is enclosed in a light alloy casing which, when secured in position by a bezel ring and joint ring, form a fuel-tight assembly.

#### Filter

11. A cylindrical wire mesh filter completely surrounds the fuel inlet on the pump, and prevents the ingress of tank sediment into the impeller system and fuel delivery line.

#### OPERATION

12. When the pump motor is energised, fuel from the tank, which enters the pump through the wire mesh filter and passes into the centrifugal impeller, is forced via the diffuser in the base through the outlet duct into the fuel delivery line.

13. Under conditions in which the flow from the pump is low due to reduced engine requirements, the impeller continues to rotate at approximately normal speed without causing any excessive increase in fuel delivery pressure.

14. When the pump is idle the delivery pressure on the underside of the by-pass valve is reduced, allowing the valve to open and enabling the engine driven fuel pump to draw fuel direct from the tank without passing through the pump impeller system.

#### REMOVAL AND INSTALLATION

##### Removal

15. Before attempting to remove a pump, ensure that the fuel tank has been drained and that the electrical supply to the pump has been switched off. The former can be checked by easing the drain plug in the delivery duct of the pump body casting, when, if there is any fuel remaining in the tank, it will have an unrestricted flow through the by-pass valve and diffuser passages of the pump to the drain plug.

16. The precise method of removing a B.P.14 or B.P.14/RS series pump is detailed in the appropriate Aircraft Handbook. In general terms it will consist of disconnecting the fuel delivery and gland drain pipes and the electrical connection plug and socket. The pump can then be removed by unscrewing the six nuts securing the pump to the tank bolt ring. Take care to support the weight of the pump during this operation. Two  $\frac{1}{4}$  in. B.S.F. bolts can be used in the tapped holes of the mounting flange to assist in breaking the joint with the tank bolt ring.

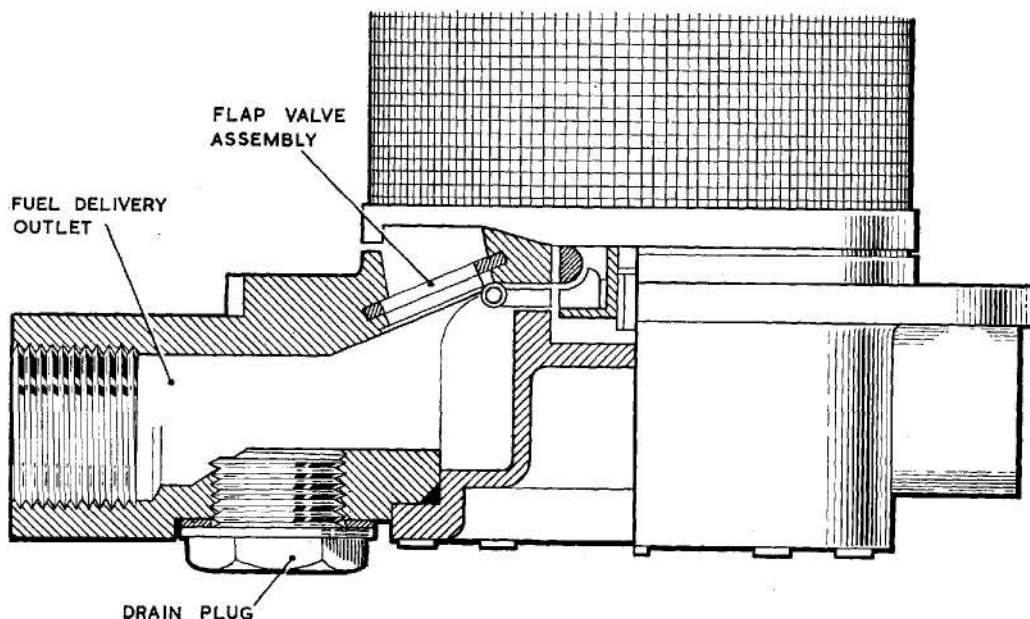

Fig. 3. Section through the delivery duct

RESTRICTED

**Pre-installation checks**

17. The installation of all new pumps should be preceded by the following checks:—

(1) Ensure that the pump has not been stored for longer than the specified maximum period (i.e. 12 months in its original packing and carton as supplied by the pump manufacturer, or 3 years where special packing has been provided). Pumps stored for periods in excess of these maxima must not be used without being dismantled, examined and tested as detailed in Vol. 6.

(2) Inspect the exterior of the pump for evidence of damage, security of locking wires, general cleanliness and corrosion. Blend out slight areas of corrosion and apply a protective finish (e.g. chromic acid solution) to the unprotected area.

(3) Check that the transit plugs have been removed from the delivery outlet, gland drain and electrical connection, and remove any tape or other protective material from the inlet filter and motor breather gauzes.

(4) It is advisable to make a starting check on the pump before installation. Apply 24V d.c. through the electrical connection. The pump must start immediately. Repeat the test several times. If the pump fails to start immediately it should be returned to an overhaul base for further serviceability testing, using approved equipment.

**Installation**

18. The above pre-installation checks apply to all aircraft installations of these pumps. For detailed instructions covering installation procedure in a particular aircraft refer to the relevant Aircraft Handbook.

19. As a general example, installation in the aircraft will comprise the following operations:—

(1) Fitting a new joint washer between the pump mounting flange and the tank stud ring, using an approved jointing compound on both sides of the washer.

(2) Securing the pump with six 2.B.A. nuts and lock washers, paying particular attention to the angular positioning of the delivery outlet and other connections for the installation in question.

(3) Reconnecting the fuel delivery and gland drain pipes, ensuring when relevant that the open end of the latter faces towards the rear of the aircraft to prevent possible pressurisation in flight.

(4) Reconnecting the electrical supply to the pump plug.

(5) Wire locking all pipe connections, union nuts, etc.

**SERVICING****Routine inspection**

20. At routine inspection, the following procedure applies:—

(1) Inspect all the pipe connections and wire locking to the pump. Check the joint between the pump and the fuel tank for leakage. Check that the motor breather gauze is not obstructed. Correct as necessary.

(2) Test the pump as detailed in para. 22-27. If the pump performance is found to be unsatisfactory in any way, the pump must be removed from the aircraft and a new or reconditioned unit fitted. No in-situ maintenance is possible.

(3) Ensure that the by-pass valve is functioning satisfactorily by completing the tests detailed in the relevant Aircraft Handbook.

21. At the periods laid down in the appropriate Servicing Schedules, all pumps are to be replaced by new or reconditioned units drawn from Stores. Faulty and time-expired pumps must be returned to a maintenance Unit or to the manufacturer for repair.

**Electrical test**

22. A routine electrical test in accordance with the appropriate Servicing Schedule should be made to ascertain that the motor unit is functioning satisfactorily. These tests must be made with the motor unit on load—i.e. immersed in and pumping fuel. The pump must be replaced by a new or reconditioned unit if there is any indication of erratic performance (e.g. excess current consumption).

**'No-fuel flow' test**

Note . . .

*The following 'No-fuel flow' electrical test is only applicable to aircraft with the*

**RESTRICTED**

necessary instrumentation. Where no test panel is provided, particular attention should be paid to the Electrical test (para. 22) and the Operational test (para. 28).

23. Ascertain the position of the aircraft pump test socket and switches by reference to the relevant Aircraft Handbook.

Proceed as follows:—

(1) Close all the fuel cocks between pumps and engines so that no fuel can flow.

(2) Connect a suitable portable ammeter to the socket on the test panel. Note that when using a clip-on type ammeter the tongs should be opened and closed smartly prior to use to reduce the hysteresis error.

(3) Start the pump by depressing the switch on the test panel (not the normal fuel pump switch). Observe the ammeter reading for a period of not less than 30 seconds.

24. Interpret the readings obtained as follows:—

(1) A steady reading not exceeding that indicated by the graph (fig. 4) for the measured applied voltage, indicates that the motor is functioning satisfactorily.

Note . . .

The graph (fig. 4) is provided as a guide to pump performance under 'no-flow' conditions. The figures derived from it must not be interpreted as forming a part of the approved Acceptance Test Specification for the pump.

(2) Current consumption in excess of the graph reading indicates a fault in the unit (e.g. faulty motor unit, a rise in torque loading due to the obstruction of moving parts, or a restriction of the fuel flow).

(3) A fluctuating reading indicates faulty contacts, defective brushes, faulty commutation or that bearings or other rotating parts are binding.

(4) A zero reading, denoting an open circuit, indicates a blown fuse, defective wiring or switch, or in extreme cases, complete motor failure.

25. When the above tests have been completed, release the test switch and disconnect the ammeter.

#### Gland leakage

26. During the above tests an examination should be made of the gland drain exit for fuel leakage. The leakage must not exceed 2 drops per minute while the pump is

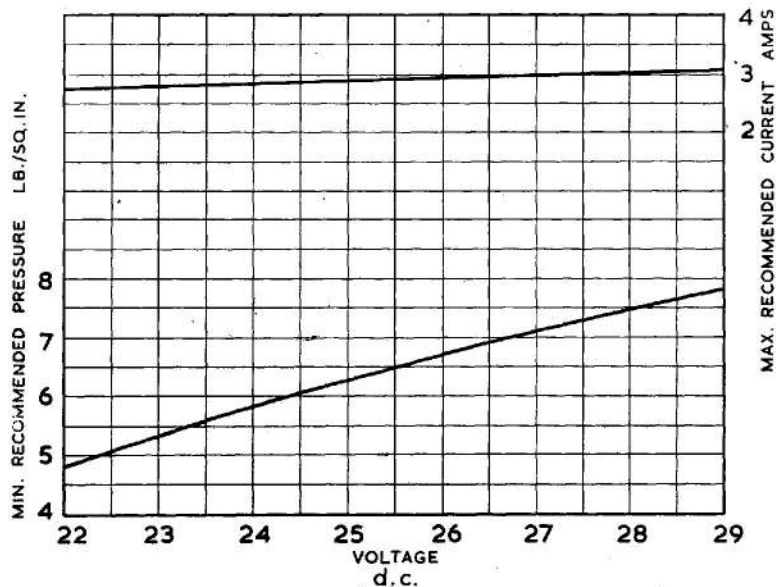

Fig. 4. 'No-fuel flow' test graph

**RESTRICTED**

running, or 1 drop per minute while stationary. Any leakage in excess of these figures will necessitate removal of the pump from the aircraft.

#### Insulation resistance test

27. Using a 500 volt insulation resistance tester for B.P.14 pumps or a 250 volt constant pressure insulation resistance tester for B.P.14/RS pumps, measure the insulation resistance between the plug pins and earth. When a new pump is drawn from Stores, the insulation resistance must be not less than 2 megohms. After installation, due to humidity conditions prevalent in aircraft at

dispersal points, the minimum permissible insulation resistance is 50,000 ohms.

#### Operational test

28. Subject to the preceding tests being completed satisfactorily, pumps that have been removed should be tested, where possible, on a suitable test rig for proof of performance, and the results obtained should be checked against the performance figures quoted in the appropriate appendix to this chapter. Refer to the relevant Aircraft Handbook for procedure details. For possible causes of failure to obtain the required performance, refer to Table 1.

**TABLE 1**  
**Faults, possible causes and rectification**

Fault	Possible causes	Rectification
Gland Leakage	(1) Bad finish between gland seal faces (2) Insufficient pressure between gland seal faces	All these conditions require that the pump is removed from the aircraft and returned to a Maintenance Unit or to the pump manufacturer for re-conditioning
Excessive current	(1) Excessive loading on metallic bellows gland (2) Faulty motor unit (3) Fouling of impeller by foreign matter	
Low delivery pressure	(1) Faulty motor unit	
Pressure surge	(1) Tight or pre-loaded bearings (2) Excessive loading on metallic bellows gland	
Low insulation resistance	Dampness in motor windings	

**RESTRICTED**



## Appendix 1

### PUMPS, FUEL, B.P.14, Mk. 2, 2A, 3 and 3A

#### LEADING PARTICULARS

Pump, fuel, Type B.P.14 Mk. 2	...	...	...	...	Ref. 5UE/5011
Pump, fuel, Type B.P.14 Mk. 2A	...	...	...	...	Ref. 5UE/
Pump, fuel, Type B.P.14 Mk. 3	...	...	...	...	Ref. 5UE/6533
Pump, fuel, Type B.P.14 Mk. 3A	...	...	...	...	Ref. 5UE/
Voltage limits	...	...	...	...	22.0/28.8V d.c.
Rated voltage	...	...	...	...	24.0V d.c.
Rated output at 24.0V d.c.	...	...	...	...	50 gal./hour
Delivery pressure at rated output/voltage	...	...	...	...	5.0 lb./in <sup>2</sup> . min.
Maximum current consumption at rated output/voltage	...	...	...	...	2.8A (AVTUR fuel)
Maximum no-flow delivery pressure at 28.8V d.c.	...	...	...	...	12.0 lb./in <sup>2</sup> .
Minimum no-flow delivery pressure	...	...	...	...	See Fig. 3, basic chapter
Electrical connection (Plessey 2CZ140052)	...	...	...	...	Ref. No. 5X/6720
Delivery outlet tapping	...	...	...	...	$\frac{1}{2}$ in. B.S.P.
Gland drain tapping	...	...	...	...	$\frac{1}{4}$ in. B.S.P.
Weight of unit	...	...	...	...	2.6 lb.

#### Introduction

1. The type B.P.14 Mk. 2, 2A, 3 and 3A fuel pumps are generally similar to that described in the basic chapter and are *not* fitted with radio interference noise suppressors.

#### Type differentiation

2. Basic differences between the various marks of B.P.14 series pumps covered by this appendix are as follows:—

##### B.P.14 Mk. 2

Basic design covered in this chapter.

##### B.P.14 Mk. 2A

Generally similar to the B.P.14 Mk. 2 pump but the inlet filter is finished electro-tin plate instead of cadmium plate to resist corrosion caused by slight acidity in the fuel.

##### B.P.14 Mk. 3

Generally similar to the B.P.14 Mk. 2 pump but a revised thrower nut incorporating a labyrinth type seal fitted to reduce the possibility of fuel ingress into the motor unit.

The ground diameter of the stator laminations is reduced to give an improved starting torque.

##### B.P.14 Mk. 3A

Generally similar to the B.P.14 Mk. 3 pump but the inlet filter is finished electro-tin plate instead of cadmium plate to resist corrosion caused by slight acidity in the fuel.

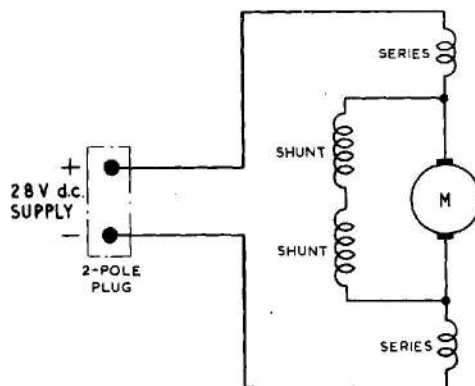

Fig. 1. Circuit diagram — B.P.14 Mk. 2, 2A, 3 and 3A pumps

RESTRICTED

## Appendix 2

### PUMP, FUEL, B.P.14/RS Mk. 2, 2A, 3 and 3A

#### LEADING PARTICULARS

Pump, fuel, Type B.P.14/RS Mk. 2	...	...	...	...	Ref. 5UE/
Pump, fuel, Type B.P.14/RS Mk. 2A	...	...	...	...	Ref. 5UE/
Pump, fuel, Type B.P.14/RS Mk. 3	...	...	...	...	Ref. 5UE/6892
Pump, fuel, Type B.P.14/RS Mk. 3A	...	...	...	...	Ref. 5UE/
Voltage limits	...	...	...	...	22.0/28.8V d.c.
Rated voltage	...	...	...	...	24.0V d.c.
Rated output at 24.0V d.c....	...	...	...	...	50 gal./hour
Delivery pressure at rated output/voltage	...	...	...	...	5.0 lb./in <sup>2</sup> ./min.
Maximum current consumption at rated output/voltage	...	...	...	...	2.8A (AVTUR fuel)
Maximum no-flow delivery pressure at 28.8V d.c.	...	...	...	...	12.0 lb./in <sup>2</sup> .
Minimum no-flow delivery pressure	...	...	...	...	See Fig. 3, basic chapter
Electrical connection (Plessey 2CZ140052)	...	...	...	...	Ref. No. 5X/6720
Delivery outlet tapping	...	...	...	...	$\frac{1}{2}$ in. B.S.P.
Gland drain tapping	...	...	...	...	$\frac{1}{4}$ in. B.S.P.
Weight of unit	...	...	...	...	2.75 lb.

#### Introduction

1. The type B.P.14/RS Mk. 2, 2A, 3 and 3A fuel pumps are generally similar to that described in the basic chapter. Radio interference noise suppressors are included in the internal electrical circuit of each pump.

#### Type differentiation

2. Basic differences between the various marks of B.P.14/RS series pumps covered by this appendix are as follows:—

##### B.P.14/RS Mk. 2

Basic design covered in this chapter.

##### B.P.14/RS Mk. 2A

Generally similar to the B.P.14/RS Mk. 2 pump but the inlet filter is finished electro-tin plate instead of cadmium plate to resist corrosion caused by slight acidity in the fuel.

##### B.P.14/RS Mk. 3

Generally similar to the B.P.14/RS Mk. 2 pump, but a revised thrower nut incorporating a labyrinth type seal fitted to reduce the possibility of fuel ingress into the motor

unit. The ground diameter of the stator laminations is reduced to give an improved starting torque.

##### B.P.14/RS Mk. 3A

Generally similar to the B.P.14/RS Mk. 3 pump but the inlet filter is finished electro-tin plate instead of cadmium plate to resist corrosion caused by slight acidity in the fuel.

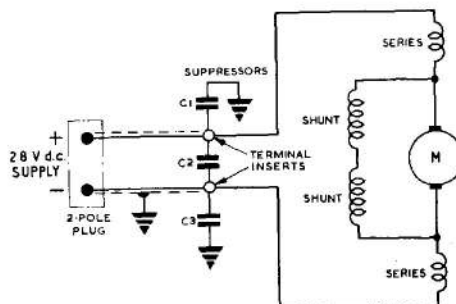
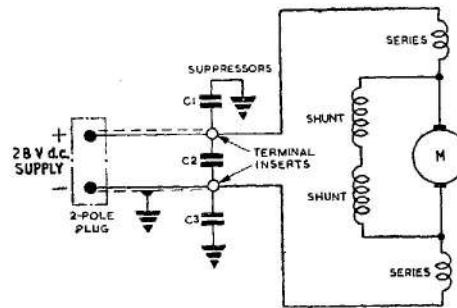
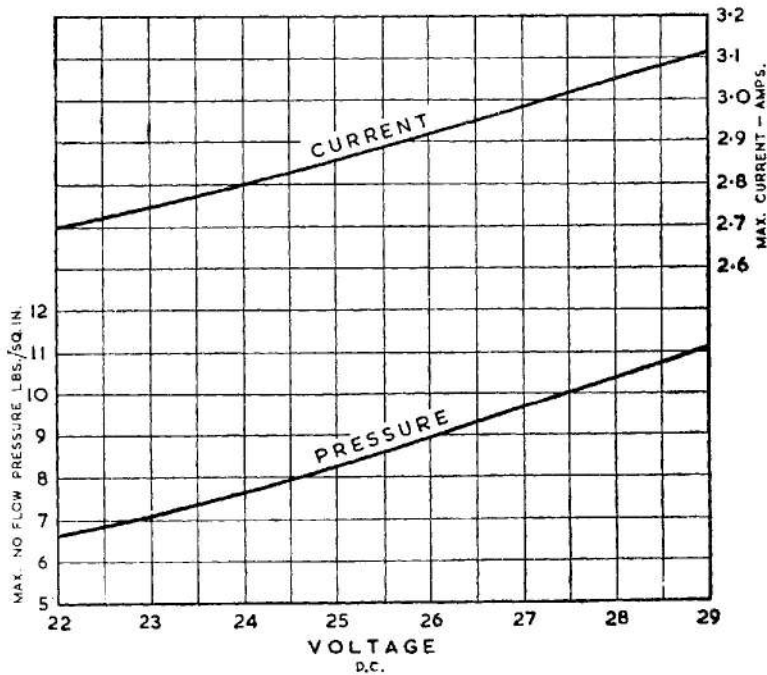

Fig. 1. Circuit diagram— B.P.14/RS, Mk. 2, 2A, 3 and 3A pumps

**RESTRICTED**

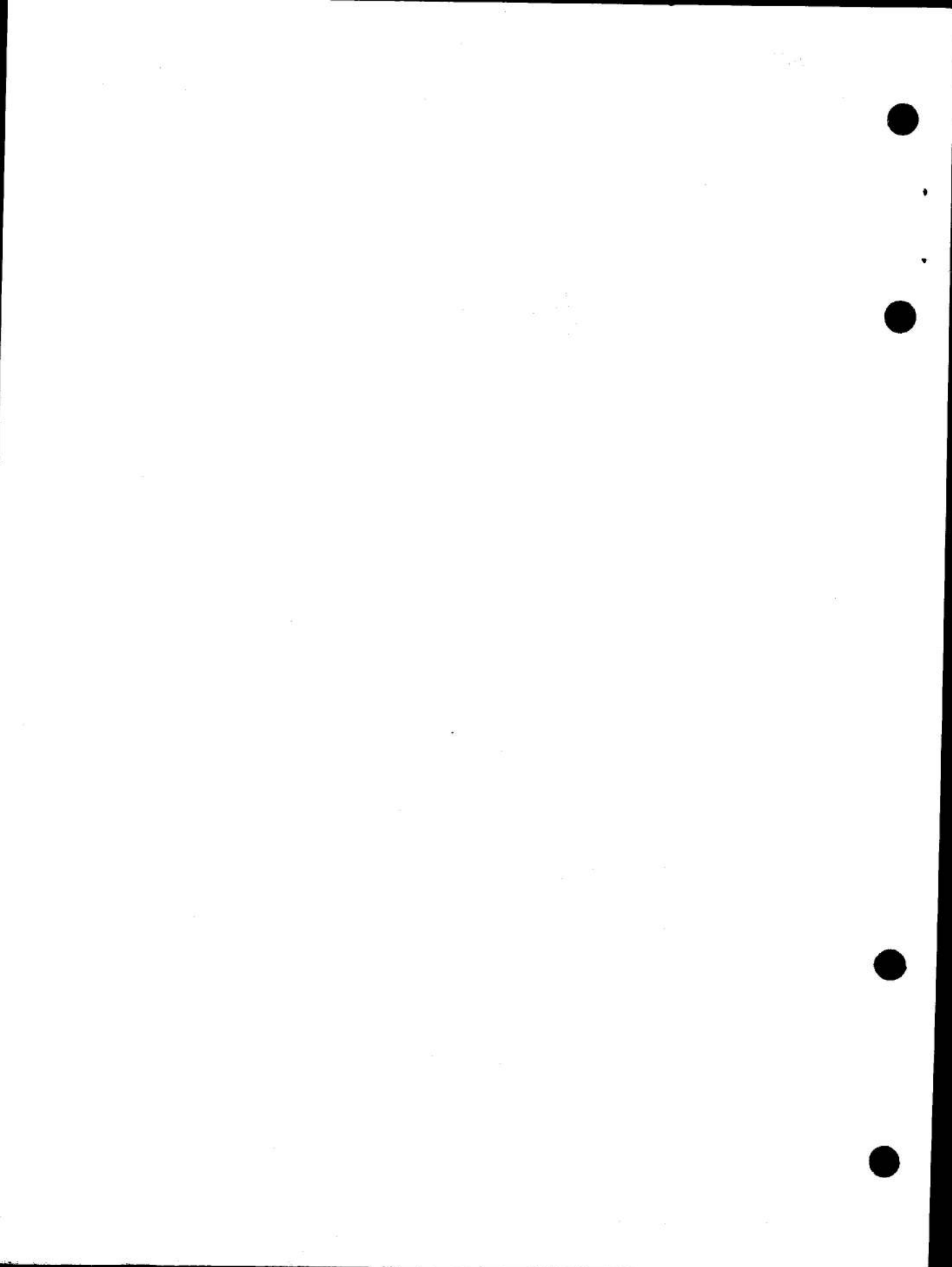

**Fig. 2** Circuit diagram of BP 14/RS, Mark 3



**Fig. 3** Performance graph of BP 14, Mk. 3 and 14/RS, Mk. 3 pumps

**RESTRICTED**



This file was downloaded  
from the RTFM Library.

Link: [www.scottbouch.com/rtfm](http://www.scottbouch.com/rtfm)

Please see site for usage terms,  
and more aircraft documents.

