

Chapter 24

PUMPS, FUEL, SPE.1302 SERIES

LIST OF CONTENTS

	<i>Para.</i>		<i>Para.</i>
<i>Introduction</i>	1	<i>Installation</i>	14
Description			
<i>Motor unit</i>	3	Servicing	
<i>Pump unit</i>	6	<i>Routine inspection</i>	16
Operation	9	<i>Electrical tests</i>	18
Removal and Installation		<i>'No-fuel flow' electrical tests</i>	19
<i>Removal</i>	11	<i>Operational test</i>	22
<i>Pre-installation checks</i>	12	<i>Gland leakage</i>	23
<i>Starting test before installation</i>	13	<i>Insulation resistance test</i>	24

LIST OF ILLUSTRATIONS

	<i>Fig.</i>		<i>Fig.</i>
<i>General view of SPE.1302 pump</i>	1	<i>Part section of suppressor housing</i>	3
<i>Sectional arrangement of typical SPE.1302 pump</i>	2	<i>'No fuel flow' test graph</i>	4
		<i>Circuit diagram</i>	5

LIST OF TABLES

	<i>Table</i>
<i>Faults, possible causes and rectification</i>	1

LIST OF APPENDICES

	<i>App.</i>
<i>Pumps, fuel, SPE.1302 Mk. 1, Mk. 2 and Mk. 3</i>	1

Introduction

1. The SPE.1302 electrically driven fuel booster pump is designed to maintain the required fuel supply to the aircraft engine-driven pump under the varying fuel temperature and altitude conditions experienced in flight. The pump is for use with a 26V d.c. aircraft supply and the internal electrical circuit includes radio noise suppressors.

2. The pump is of the direct drive type and when installed it is completely housed within the fuel tank. All connections to the pump are inside the tank and must therefore

be made before fitting its mounting plate to the tank. The mounting plate forms a part of the aircraft tank structure. Details of the differences between the various SPE.1302 mark numbers, together with the leading particulars, are given in an appendix to this chapter.

DESCRIPTION**Motor unit**

3. A typical pump assembly is illustrated in Fig. 2 and 3. The motor unit is a totally enclosed compound wound four pole machine designed to operate on a 26V d.c. supply.

RESTRICTED

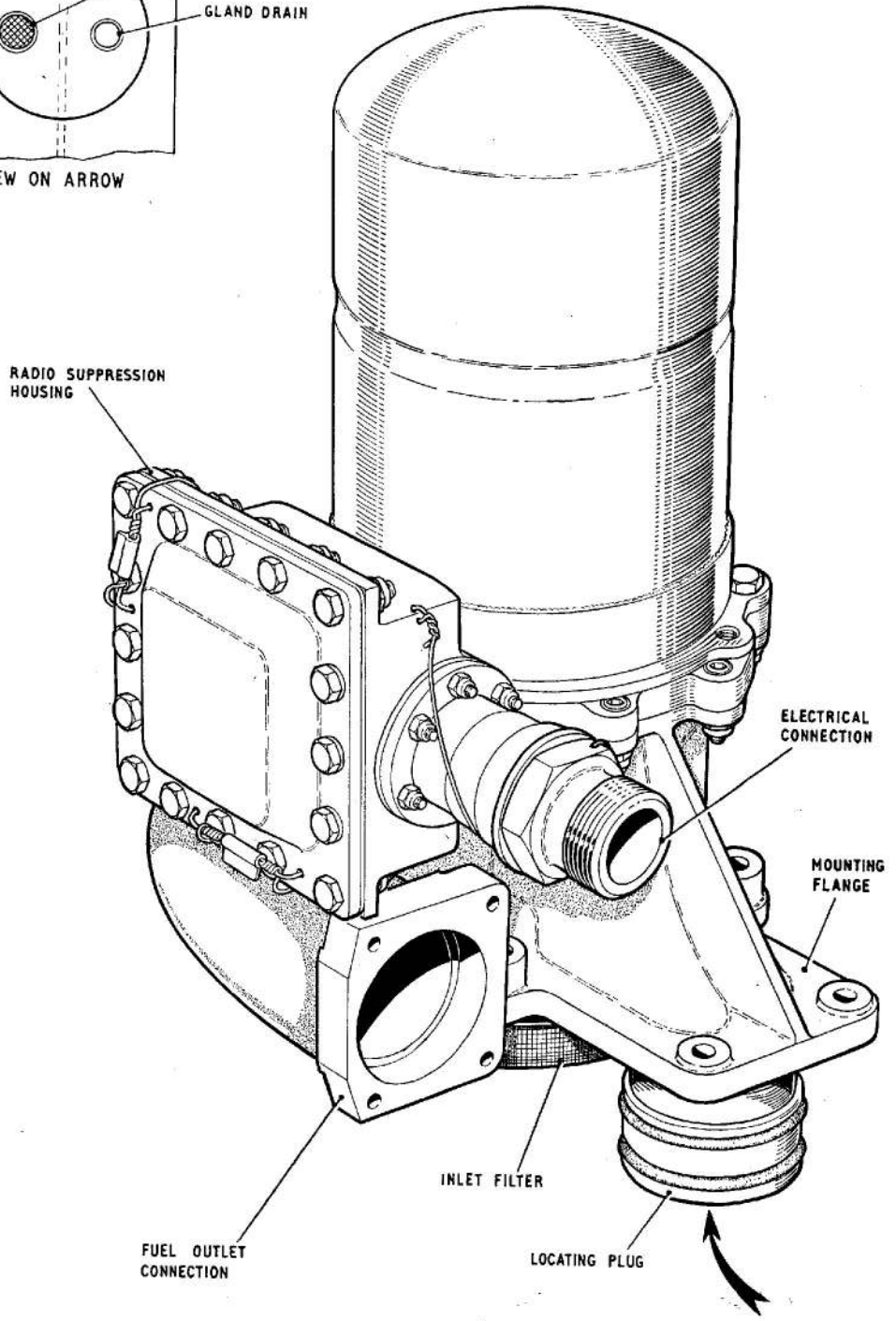
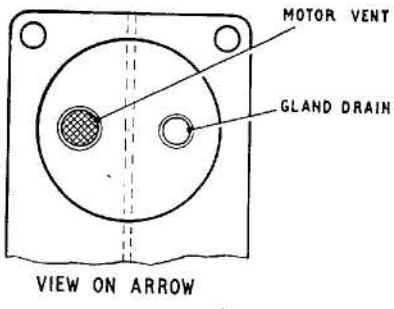

Fig. 1. General view of SPE.1302 pump

RESTRICTED

It locates in the pump casting and is bolted in position through a flange on the lower motor casing. The armature is supported by shielded bearings, the inner race of the lower bearing being secured to the armature shaft by a labyrinth seal type thrower ring which will fling off any fuel, which has seeped past the main gland, before it can enter the motor unit. Both bearings are pre-packed with an anti-freeze/high melting point grease during manufacture and cannot be re-lubricated.

4. The brush gear is of unit construction and comprises four brushes in boxes mounted, singly at 90 degrees spacing, to a silicone bonded glass paxolin carrier.

5. Radio interference noise suppression units are fitted away from the motor unit in a cast housing which forms a part of the pump body casting (fig. 3).

Pump unit

6. The two stage centrifugal pump unit comprises a first stage helical impeller and second stage centrifugal impeller mounted to the extended armature shaft. Fuel from the impeller system is fed into a spiral volute which is an integral part of the pump body casting. This casting also houses the main gland which prevents fuel ingress into the motor unit. Any slight seepage past this gland will drain to atmosphere through a cored channel in the casting which has its exit in the boss which forms a part of the mounting flange of the pump. A second gland drain connection is made to a tapping on the body of the pump casting, to drain any fuel seepage past the gland when the aircraft wings are folded during stowage. Motor venting is through a separate cored channel in the pump casting.

7. A wire mesh filter is fitted between the impeller system and the base of the fuel tank to prevent ingress of any tank sediment into the fuel delivery line. Air and fuel vapour, evolved under operating conditions, is dissipated from the tips of the helix blades and is directed out of the fuel entering the impeller system by a formed vapour guide cone fitted around the inlet.

8. The electrical connection on the pump unit is of special fuel tight design, mating

with a socket on a lead assembly within the tank.

OPERATION

9. Fuel from the tank is picked up by the helical impeller which serves the dual purpose of de-aerating and pressurising the fuel at the eye of the centrifugal impeller. This latter forces the fuel through the spiral volute and into the delivery line.

10. Under conditions in which the flow from the pump is low due to reduced engine requirements, the impeller continues to rotate at approximately normal speed without causing any excessive increase in fuel delivery pressure.

REMOVAL AND INSTALLATION

Removal

11. Before attempting to remove a pump ensure that the tank has been drained of fuel and that the electrical supply to the pump motor unit has been switched off. For precise details of the removal procedure applicable to a particular installation, refer to the relevant Aircraft Handbook. Generally, removal will comprise the withdrawal of the mounting plate bolts to separate the mounting plate from the tank, care being taken to support the weight of the pump during this operation. At this stage it will only be possible to partly withdraw the unit depending on the length of the flexible electrical delivery, and the gland drain connections to the pump within the tank. With the pump suitably supported, these connections should be dismantled and the four bolts securing the pump to the mounting plate removed. Separate the pump from the mounting plate by withdrawing the gland drain boss of the pump casting from its housing in the mounting plate.

Note . . .

The mounting plate is part of the aircraft tank structure and reference should be made to the relevant Aircraft Handbook for further instructions appertaining to it.

Pre-installation checks

12. The installation of all new pumps should be preceded by the following checks:—

- (1) Ensure that the pump has not been stored for longer than the specified

RESTRICTED

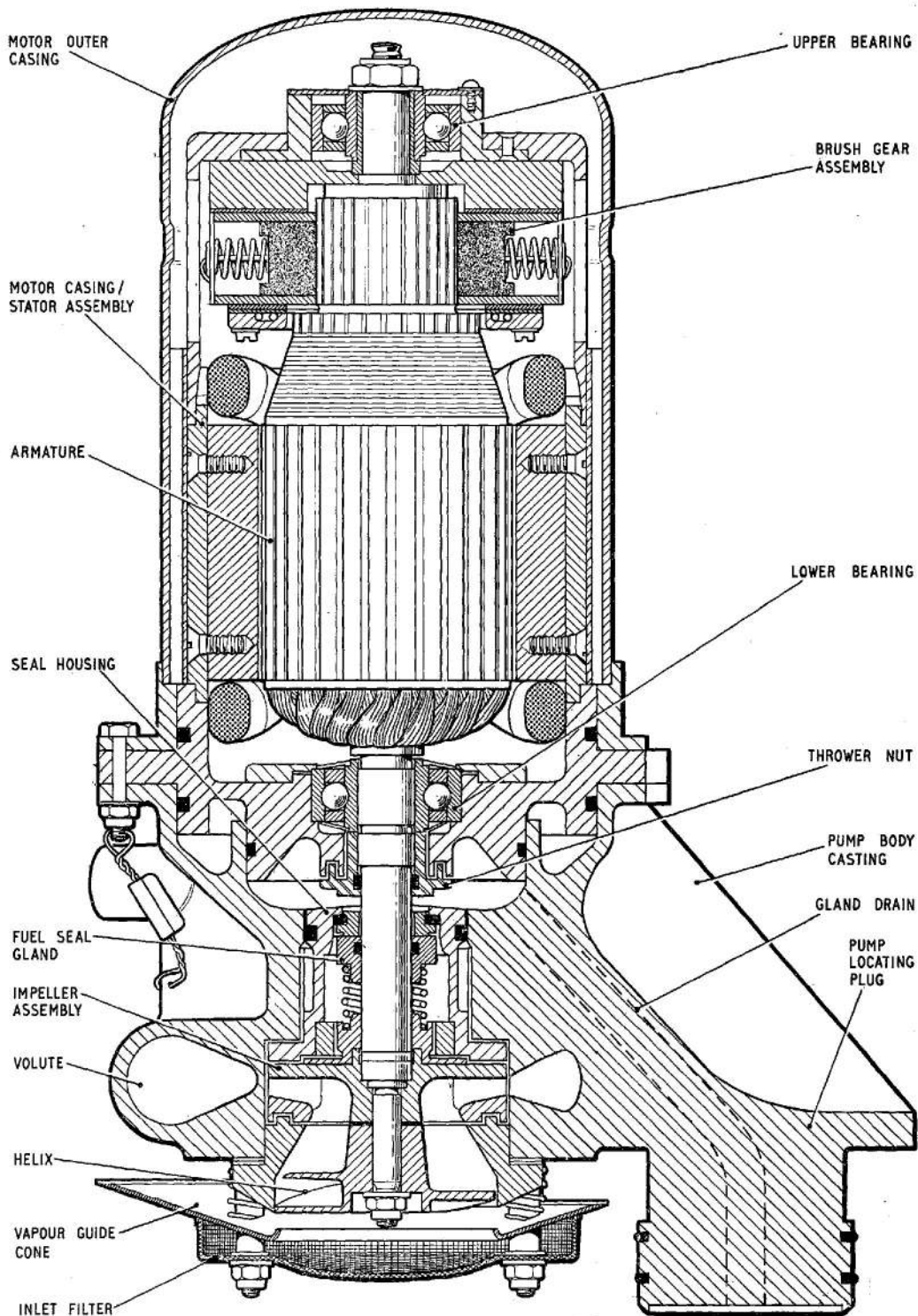

Fig. 2. Sectional arrangement of typical SPE.1302 pump

RESTRICTED

maximum period (i.e. 12 months in the original packing and carton as supplied by the manufacturer, or 3 years where special packing has been provided). Pumps stored for longer periods must not be used without being dismantled, examined and tested as detailed in Vol. 6.

(2) Inspect the exterior of the pump for evidence of damage and security of locking wires and seals at the motor unit outer casing fixing bolt, inlet filter and capacitor housing cover.

(3) Check that transit plates, plugs and/or tape have been removed from the delivery outlet, gland and motor vent boss, and the electrical connection.

Starting test before installation

13. Apply a 26V d.c. supply through the electrical connection on the capacitor housing. The pump should start immediately. If it starts satisfactorily, switch off the supply and repeat the test several times. If the pump fails to start immediately it should be returned to an overhaul base for further serviceability testing using approved equipment.

Installation

14. For detailed procedure covering installation in a particular aircraft, reference should be made to the relevant Aircraft Handbook.

15. As a general example, installation in the aircraft of a pump which has completed the pre-installation checks, will comprise the following operations:

(1) Ensuring that new seal rings have been fitted in the two grooves of the pump mounting boss.

(2) Checking that mounting plate seals and gaskets have been replaced as detailed in the appropriate Aircraft Handbook.

(3) Smearing an approved silicone grease on the seal rings in the pump mounting boss before locating in the mounting plate. Securing the pump to the mounting plate with four bolts and lockwashers.

(4) Reconnecting the internal tank electrical, delivery line and secondary gland connections to the pump and effecting any security measures required.

(5) Securing the pump mounting plate to the fuel tank bolt ring as detailed in the relevant Aircraft Handbook.

SERVICING

Routine inspection

16. At routine inspections the pump should be tested in-situ as detailed in para. 18-24. If the pump is found to be defective in any way, a new or reconditioned unit must be fitted. No in-situ maintenance is possible.

17. At the periods laid down in the appropriate Servicing Schedule, all pumps are to be replaced by new or reconditioned units drawn from Stores. Faulty and time-expired pumps must be returned to a Maintenance Unit, or to the manufacturer, for repair.

Electrical tests

18. A routine electrical check in accordance with the appropriate Servicing Schedule should be made to ascertain that the motor unit is functioning satisfactorily. These tests must be made with the motor unit on load—i.e. with the pump immersed in and pumping fuel. The pump must be replaced by a new or reconditioned unit if there is any indication of erratic performance, such as excessive current consumption, or unusual running feature.

Note . . .

The following 'no-fuel flow' electrical test is only applicable to aircraft with a test panel. Where no provision is made for this test, particular attention must be paid to the Electrical Test (para. 18) and Operational Test (para. 22).

'No-fuel flow' electrical test

19. Ascertain the position of the pump test socket and switches, then proceed as follows:—

(1) Close all fuel cocks between the pump and engine to ensure that no fuel can flow.

(2) Connect a suitable portable ammeter to the socket on the panel.

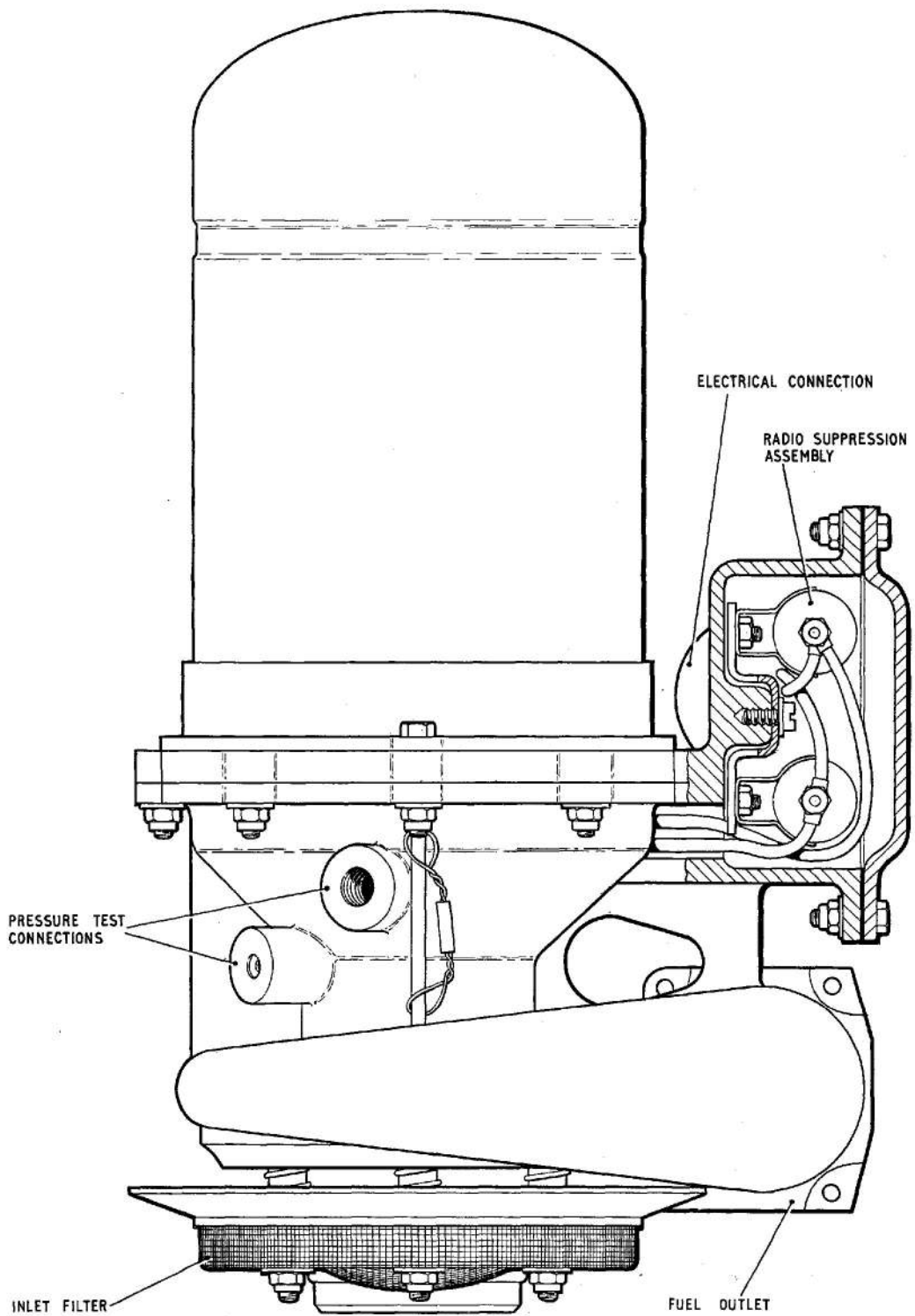

Fig. 3. Part section of suppressor housing

RESTRICTED

(3) Switch on the pump by pressing the switch on the test panel (not the normal fuel pump switch) and note the reading of the ammeter for a period of not less than half-a-minute.

Note . . .

When using a clip-on type ammeter, open and close the tongs smartly before use to reduce the hysteresis errors.

20. Interpret the readings obtained as follows:—

(1) A steady reading not exceeding the figure obtained from the graph (fig. 4) for the measured applied voltage, indicates that the motor unit is satisfactory.

Note . . .

The graph (fig. 4) is provided as a guide to pump performance under no-flow conditions: the figures derived from it are not to be interpreted as forming a part of the Approved Test Specification for the pump.

(2) A current consumption in excess of the graph reading indicates either a faulty motor unit, a rise in torque loading due to the obstruction of moving parts or a restriction of the fuel flow.

(3) A fluctuating reading indicates faulty contacts, defective brushes, faulty commutation, or that bearings or other rotating parts are binding.

(4) A zero reading indicates an open circuit and is consistent with a blown fuse, defective switch, faulty wiring, or a complete motor failure.

21. When these tests have been completed, release the test switch and disconnect the ammeter from the test socket.

Operational test

22. Subject to the electrical test being satisfactory, the pump should be tested where possible for proof of performance, and checked against the figures given in the appropriate Appendix to this chapter. For possible causes of failure to obtain the quoted performance see Table 1.

Gland leakage

23. During the tests an examination should be made of the gland drain exit in the mounting plate boss for fuel leakage. The leakage rate must not exceed $\frac{1}{4}$ c.c. in any 15 minute period when the pump is stationary, or $\frac{1}{2}$ c.c. in any 15 minute period when running.

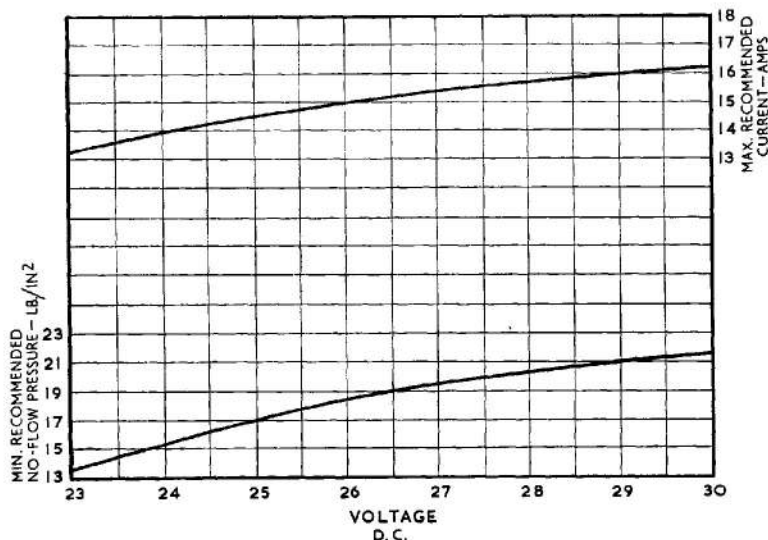

Fig. 4. 'No fuel flow' test graph

RESTRICTED

Note . . .

When the aircraft wings are in the folded position, the gland drain to the under-surface of the wing is inoperative, and the check must be made at the second gland drain outlet (for position, refer to the relevant Aircraft Handbook).

Insulation resistance test

24. Using a 250V constant pressure insulation resistance tester, measure the insulation resistance between the plug pins of the external (tank) electrical connection and earth. When a new pump is installed, the insulation resistance must be not less than 2 megohms. After installation, due to humidity conditions at aircraft dispersal points, the minimum permissible insulation resistance is 50,000 ohms.

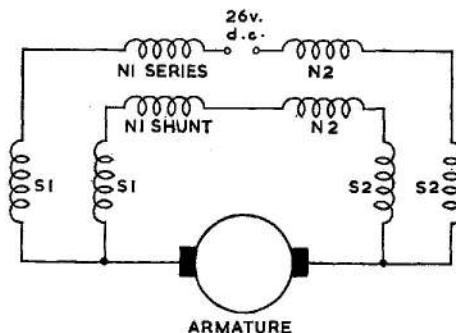

Fig. 5. Circuit diagram

TABLE 1

Faults, possible causes and rectification

Fault	Possible cause	Rectification
Gland leakage	<ul style="list-style-type: none"> (1) Bad finish between gland faces. (2) Insufficient pressure between gland seal faces. (3) Faulty seal rings in gland assembly. 	All these conditions require that the pump is removed from the aircraft and returned to a Maintenance Unit or to the pump manufacturer for reconditioning.
Excessive current consumption.	<ul style="list-style-type: none"> (1) Excessive gland loading. (2) Faulty motor unit. (3) Moving parts (e.g. impeller) fouled by foreign matter. 	
Low delivery pressure	<ul style="list-style-type: none"> (1) Faulty motor unit. 	
Pressure surges	<ul style="list-style-type: none"> (1) Tight or pre-loaded bearings. (2) Excessive gland loading. 	
Low insulation resistance	<ul style="list-style-type: none"> (1) Dampness in motor windings. 	

Appendix 1

PUMPS, FUEL, SPE.1302 MK. 1, MK. 2 AND MK. 3

LEADING PARTICULARS

Pump, fuel, Type SPE.1302 Mk. 1	Ref. No. 5UE/7242
Pump, fuel, Type SPE.1302 Mk. 2	Ref. No. 5UE/7426
Pump, fuel, Type SPE.1302 Mk. 3	Ref. No. 5UE/7883
Voltage limits 25-29V d.c.
Operating voltage 26V d.c.
Rated output at operating voltage 1200 g.p.h.
Fuel delivery pressure at rated output/operating voltage 13.0 lb./in ² (min.)
Maximum current consumption at rated output/operating voltage 16.5A
Minimum no-flow delivery pressure at 26V d.c. 18.5 lb/in ²
Electrical connection on pump....	SPE.12418 (special)
Delivery outlet on pump Special
Weight of unit 12.5 lb.

Introduction

1. The Type SPE.1302 Mk. 1, Mk. 2 and Mk. 3 fuel pumps are similar to that described in the basic chapter. The Mk. 2 pump differs from the Mk. 1 unit in that a longer gland spring is fitted to increase the efficiency of the seal. The Mk. 3 pump differs from the Mk. 2 unit in that it incorporates improved sealing of the electrical connection to prevent fuel ingress into the suppression chamber.

Note . . .

The difference between the Mk. 3 and Mk. 2 and Mk. 1 pumps detailed above are correct at the date of issue of this appendix. Subsequent modifications affecting Mk. 3 pumps but not necessarily incorporated in Mk. 1 and Mk. 2 units may increase the points of difference.

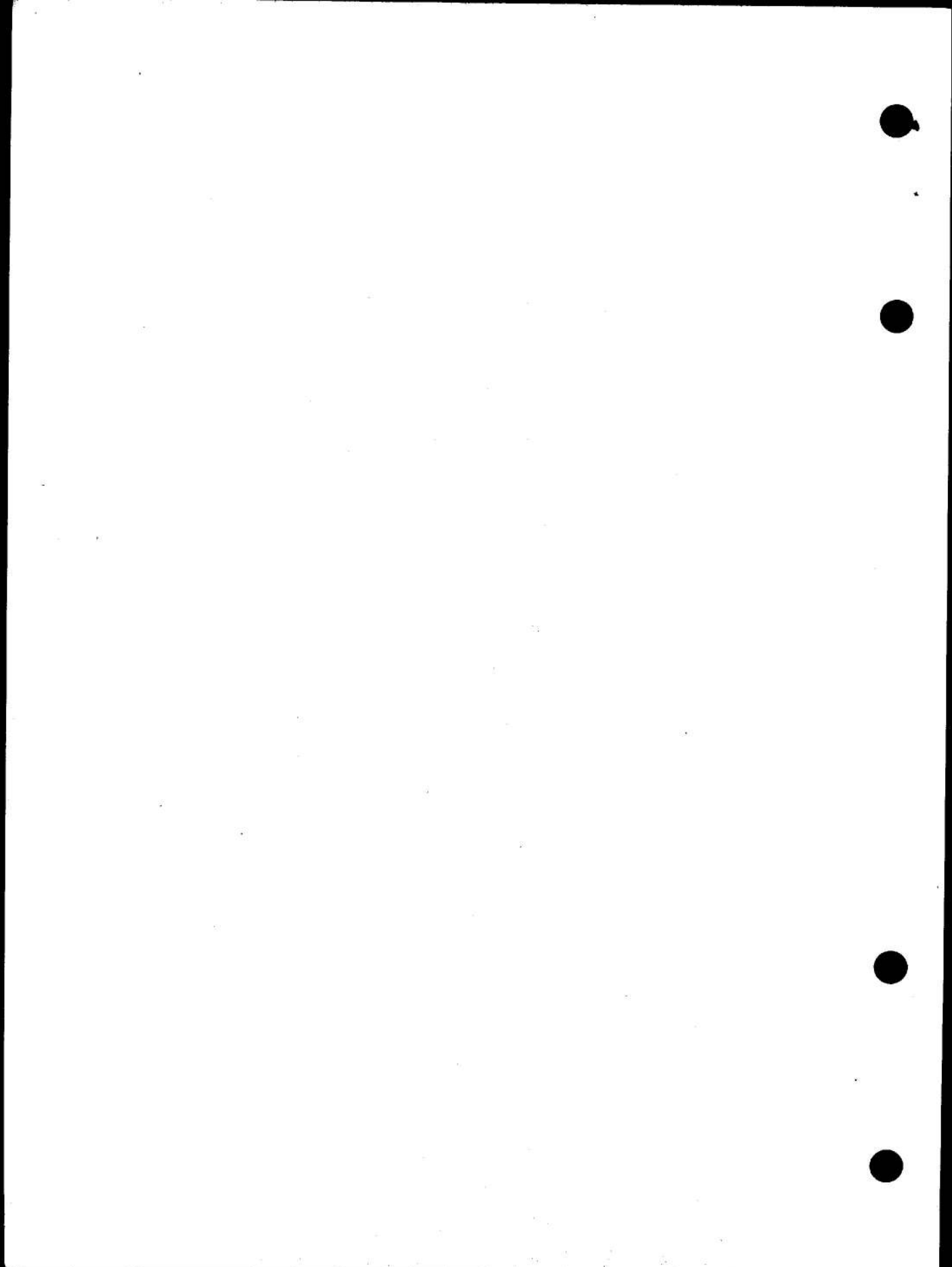

This file was downloaded
from the RTFM Library.

Link: www.scottbouch.com/rtfm

Please see site for usage terms,
and more aircraft documents.

