

Chapter 31

PUMP, FUEL, CH 4, Mk. 3

LIST OF CONTENTS

	Para.		Para.
Introduction	1	Relief valve	4
Description		Servicing	5
Pump unit	2		

LIST OF ILLUSTRATIONS

	Fig.		Fig.
Sectional view of pump	1	Part sectional view of pump	2

LEADING PARTICULARS

Pump, fuel, CH 4, Mk. 3	Stores Ref. 5UE/634I
Delivery rate	10 gallons per hour
Delivery pressure	100 lb. per sq. in.
Current consumption	4.25 amp.
Operating voltage	26 volts
Weight	5 lb. 13 oz.
Electrical connection	2-pole Breeze plug

Introduction

1. This pump is designed to deliver fuel at high pressure to the aircraft combustion heaters. It is installed vertically at the bottom of the supply tank, both the inlet and the motor being immersed in fuel.

DESCRIPTION

Pump unit

2. The pump unit differs slightly from that described in A.P.4343, Vol. 1, Sect. 16, Chap. 4, as does the relief valve, but in all other particulars the units are similar. Pumping is effected by one long and one short stainless steel gear running in mesh between aluminium alloy plates which are faced with poly-tetra-fluoro-ethylene. The gears are located in a tungum steel pump chamber.

3. The pump gear unit is driven directly from the armature shaft through a semi-flexible coupling to the long gear, which is geared to the short gear. The upper and lower aluminium alloy bearing blocks which

back the poly-tetra-fluoro-ethylene faced plates, are each fitted with two carbon bearing bushes, and serve as gear shaft bearings. An upper and lower cover plate secured by two stainless steel dowel pins and slotted nuts completes the assembly. The complete unit is secured in the pump base casting by a flanged cover and distance piece, made leak proof by two paper washers and held by six 4 B.A. screws, nuts and washers.

Relief valve

4. The relief valve consists of a stainless steel ball, held on its seating by a calibrated spring which limits the delivery pressure to a pre-determined figure. As will be seen in fig. 2, the valve is fitted in a recess on the upper face of the pump base in the fuel delivery outlet line.

SERVICING

5. Servicing is as described in A.P.4343, Vol. 1, Sect. 16, Chap. 4, to which reference should be made as required.

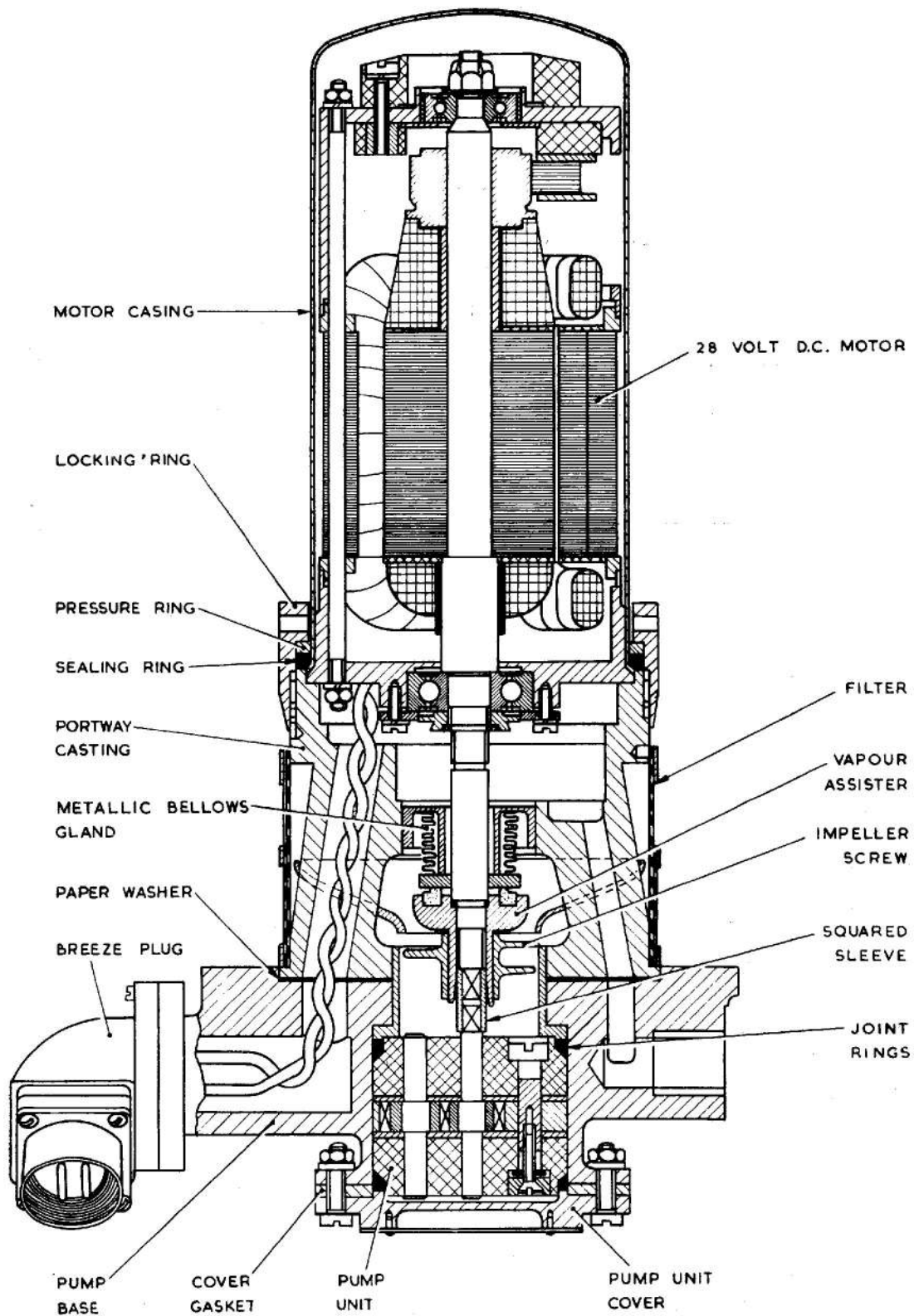

Fig. 1. Sectional view of pump

RESTRICTED

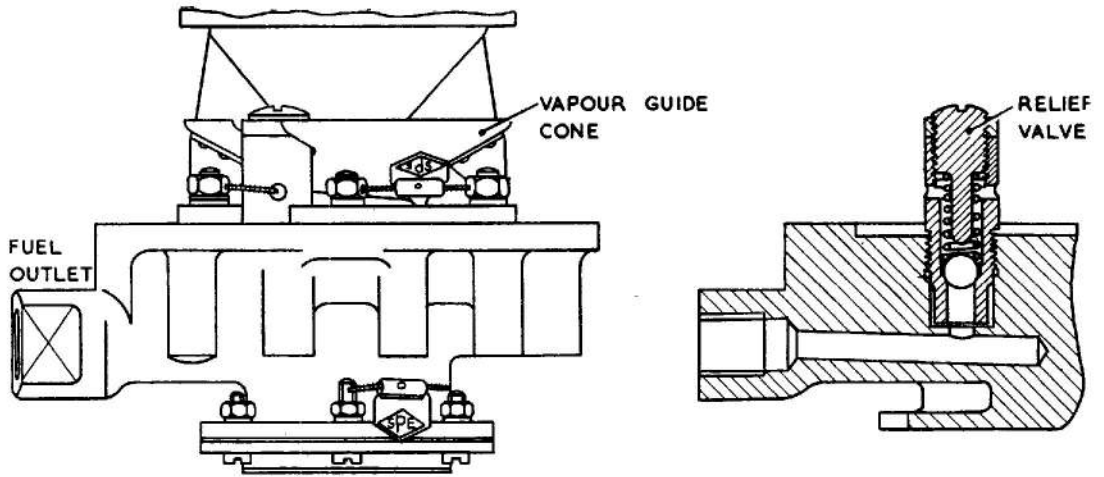

Fig. 2. Part sectional view of pump



This file was downloaded
from the RTFM Library.

Link: www.scottbouch.com/rtfm

Please see site for usage terms,
and more aircraft documents.

