

Chapter 36

PUMP, FUEL, EF6, Mk. 3

LIST OF CONTENTS

	Para.		Para.
Introduction	1	By-pass valve	10
Description		Principle of operation	11
General	2	Installation	12
Motor and gear box	3	Servicing	
Pump unit	6	Routine inspection	16
Gland seal	7	Insulation resistance test	19
Relief valve	8		

LIST OF ILLUSTRATIONS

	Fig.		Fig.
General view of pump	1	Cross-sectional view	3
Sectional view of pump	2	Circuit diagram	4

LEADING PARTICULARS

Pump, fuel, EF6, Mk. 3	Stores Ref. 5UE/5417
Delivery rate	310 gall. per hr.
Pressure	12 lb. per sq. in.
Nominal voltage	24 volt. d.c.
Normal F.L. current	13.5 amp.
Weight	8.5 lb.
Relief valve preset pressure at zero flow	17 lb. per sq. in.

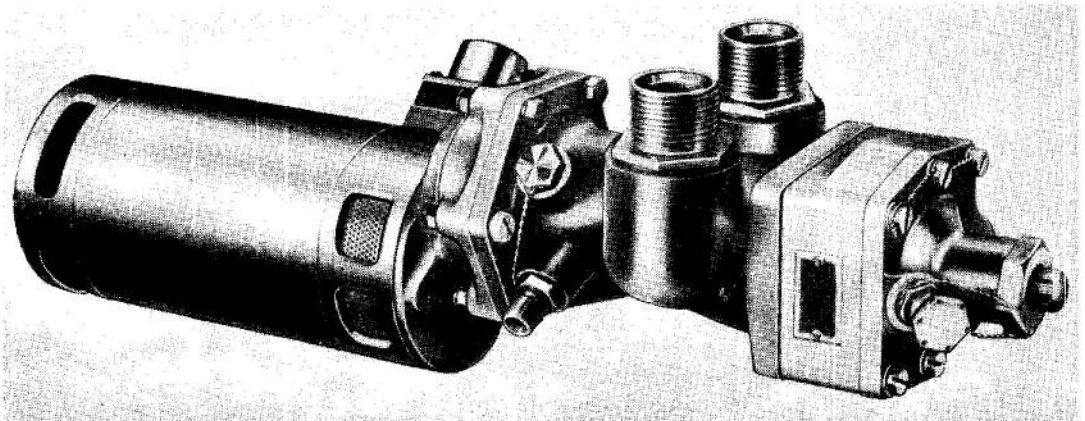
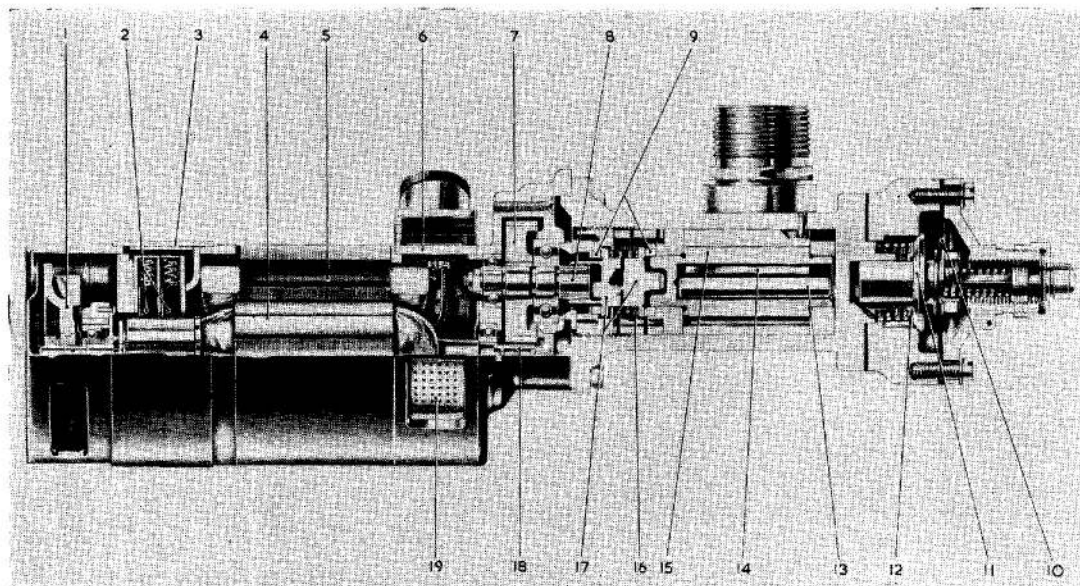

Fig. 1. General view of pump



- | | | | |
|---------------------|-----------------------|------------------|------------------------|
| 1 COOLING FAN | 6 ADAPTOR RING | 11 RELIEF VALVE | 16 SEAL LOADING SPRING |
| 2 TWIN BRUSH SET | 7 DRIVEN GEAR | 12 BY-PASS VALVE | 17 UNIVERSAL COUPLING |
| 3 INSPECTION COVER | 8 SPLINED DRIVE SHAFT | 13 CENTRAL PIN | 18 DRIVER GEAR |
| 4 ARMATURE ASSEMBLY | 9 CARBON RING | 14 SLIDING VANE | 19 COOLING VENT |
| 5 FIELD ASSEMBLY | 10 DIAPHRAGM | 15 ROTOR | |

Fig. 2. Sectional view of pump

Introduction

1. The EF6 Mk. 3 is an electrically driven pump designed for use either as a booster in the fuel supply line or as a transfer pump; it may also serve as an emergency pump to provide a direct supply in the event of failure of the main-engine driven-pump.

DESCRIPTION

General

2. The complete unit consists of a pump unit and a driving motor, the latter having a self-contained gear box.

Motor and gear box

3. The motor is of the fan cooled flame-proof type, compound wound and suitable for continuous operation. The d.c. operating voltage is from 16 volts (min.) for starting, to 22 to 29 volts for running. At 24 volt d.c. the full load speed is approximately 3,000 r.p.m. and a single stage reduction gear box, ratio 3.66:1, is housed in the drive end frame; power rating is 0.25 b.h.p. at 24 volt., current consumption 13.5 amp.

4. The armature shaft runs in ball bearings housed in the two end frames, between which are located the laminated field

assembly and an adaptor ring which carries the Breeze connection plug; the whole assembly is rigidly secured by two bolts passing through from one end frame to the other. Commutator and brush gear are located at the end remote from the gear box and may be inspected by removal of the circular band covering apertures in the end frame. A cooling fan is also mounted on the armature shaft at the commutator end, the air being drawn in at the gear box end; all cooling vents are flameproofed.

5. The gear assembly consists of a hardened steel pinion fitted to an extension of the armature shaft, and a fabric bakelite gear mounted on the ball bearing supported output shaft.

Note . . .

The gears are lubricated on assembly with anti-freeze grease D.T.D. 825, Stores Ref. 34B/9100512.

Pump unit

6. This consists, essentially, of an aluminium alloy housing containing a hardened meehanite sleeve, this sleeve having an eccentric bore in which the pumping rotor

RESTRICTED

with four equally spaced sliding vanes is rotated. Since these parts are machined and fitted with a high degree of accuracy, the drive to the rotor is effected by means of a universal—Oldham type—coupling, which takes up even small magnitudes of misalignment between the axis of the rotor and that of the gear box output shaft.

Gland seal

7. To prevent leakage, two face type seals are provided—one by spring loading the flange of the universal block against a stationary carbon ring inserted in the face of the rotor bearing, and the other by (the same) spring loading of a flange on the drive shaft against a carbon ring insert in the locknut. This gland chamber is provided with two draining outlets.

Note . . .

Lubrication of the pump is provided by the circulating fuel. No other lubrication is necessary.

Relief valve

8. The relief valve assembly is contained in a separate housing at the end of the pump body. Its function is to govern the delivery pressure, and to provide a means of bypassing excess delivery back to the inlet side.

9. It consists of a spring-loaded valve on a seating which separates two chambers, one of these being vented to the delivery side, and the other to the inlet side, of the pump; the spring loading is adjusted to the required maximum delivery pressure. Also mounted on the stem of the valve is a diaphragm separating the inlet side from a third chamber which is vented either to atmosphere or to engine induction pressure. Now the area of the diaphragm is the same as that of the seated valve, so that

- (a) The delivery pressure at which the valve operates is completely independent of inlet pressure conditions,
and
- (b) The delivery pressure at which the valve operates is automatically controlled with respect to atmospheric or induction conditions.

Two, alternative, positions are provided for the atmospheric or induction vent. The small size of the (restrictor) hole in the

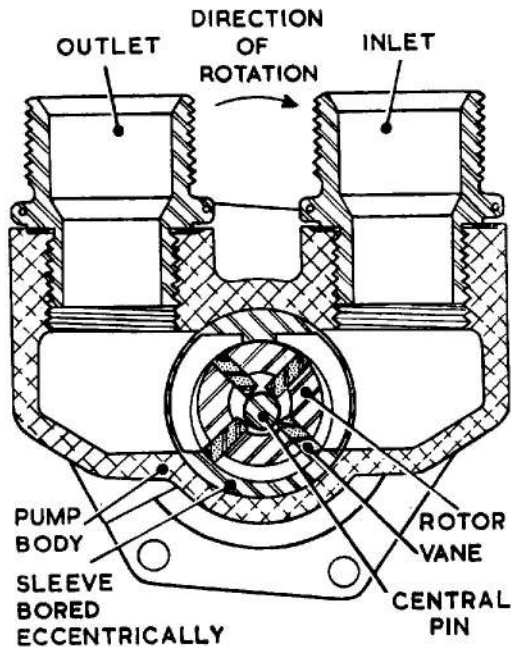

Fig. 3. Cross-sectional view

union, and in the vent nut, prevents excessive leakage in the event of failure of the diaphragm.

Note . . .

The relief valve is set at the factory to operate at 17 lb. per sq. in. at zero flow (delivery blanked off) and 29 volts. It should not be set to operate at any higher value.

By-pass valve

10. The by-pass valve allows fuel to pass through the pump when it is stationary. It consists of a spring loaded disc-valve with ports in the seated relief valve.

Principle of operation

11. The pump is of the single-stage positive displacement type. The action, in the present design, will be evident from the cross-sectional view (fig. 3). This shows, also, how the rotating vanes are constrained to slide in the rotor; the central pin is floating.

INSTALLATION

12. The unit must be installed in accordance with the instructions in the relevant Aircraft Handbook. A suitable filter must be included in the inlet line to the pump.

13. To fit a replacement pump, remove any transit protective coverings, including dust covers on the pump, and on the motor connection fittings. If practicable, apply 24 volt. d.c. to the motor: if it does not rotate quite freely and steadily the unit should be rejected.

14. The unit may be mounted with any desired orientation from horizontal to vertical, but when not horizontally mounted the motor must always be uppermost. The disposition of the pump ports may be altered as required by rotating the unit, care being taken that, when it is mounted horizontally, one of the two gland drain connections is on the underside and within 65 deg. of the vertical centre line.

15. Connect up the ports, the drain union, and the atmospheric induction union, also the electrical connection; polarity of the latter does not affect direction of rotation. If a pressure balance connection other than to atmosphere is not required, the original vent nut must be retained as this incorporates an atmospheric vent hole. Ensure that this hole is clear: a stoppage will result in fluctuating delivery pressure and a general rise in pressure with altitude.

SERVICING

Routine inspection

16. Any failure of the internal mechanism will be shown up immediately by erratic performance, e.g., loss of delivery pressure or excessive gland leakage. Such pumps must be returned to the manufacturers for examination and reconditioning.

17. Inspection in the aircraft should be made for security of fixing and in particular the bolts securing the pump to its motor.

All locking wires should be examined and replaced where necessary, and any fuel leakage from the pump connections should be rectified by fitting new sealing gaskets. The electrical connections should also be checked.

18. Where the relief valve diaphragm is vented to atmosphere, ensure that the hole in the vent nut (0.0135 in. dia.) is clear by passing through a wire of appropriate size. The diameter of the hole must not be enlarged, and air blast must not be used for clearing, since such pressure might damage the diaphragm.

Note . . .

Servicing will be carried out in accordance with the base servicing schedules.

Insulation resistance test

19. Using a 250 volt insulation resistance tester, measure the insulation resistance between the electrical circuit and earth. This test can be effected at the Breeze plug, whilst still installed in the aircraft. The insulation resistance must not be less than 50,000 ohms.

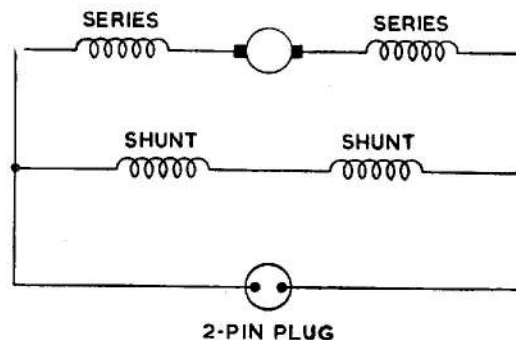

Fig. 4. Circuit diagram

This file was downloaded
from the RTFM Library.

Link: www.scottbouch.com/rtfm

Please see site for usage terms,
and more aircraft documents.

