

Chapter 42

PUMPS, FUEL, SPE.2009 AND SPE.2009A

LIST OF CONTENTS

	<i>Para.</i>		<i>Para.</i>
<i>Introduction</i>	1	<i>Pre-installation checks</i>	18
Description	4	<i>Installation</i>	19
<i>Pump base</i>	5	Servicing	
<i>Upper base</i>	7	<i>Routine inspection</i>	21
<i>Motor unit</i>	9	<i>Electrical test</i>	23
<i>Thrower assembly</i>	11	<i>Operational test</i>	27
Operation	13	<i>Gland leakage test</i>	28
Removal and installation		<i>Insulation resistance test</i>	29
<i>Removal</i>	16		

LIST OF ILLUSTRATIONS

	<i>Fig.</i>
<i>External view of typical SPE.2009/ SPE.2009A fuel pump</i>	1
<i>Sectional view of typical SPE.2009 fuel pump</i>	2
<i>Sectional view of pump fuel outlet</i> ...	3
<i>'No fuel flow' electrical test graph</i> ...	4
<i>Circuit diagram, SPE.2009</i>	5

LIST OF TABLES

	<i>Table</i>
<i>Faults, possible causes and rectifica- tion</i>	1

LIST OF APPENDICES

	<i>App.</i>
<i>Pumps, fuel, Type SPE.2009 Mk. 4, Mk. 5, Mk. 6 and Mk. 7</i>	1
<i>Pumps, fuel, Type SPE.2009A Mk. 4, Mk. 5, Mk. 6 and Mk. 7</i>	2

Introduction

1. Type SPE.2009 and SPE.2009A Series fuel booster pumps are electrically driven self-contained units designed to supply fuel under pressure to the aircraft engine-driven

pump or alternatively to transfer fuel from auxiliary to main tanks. Installation is made in the base of the aircraft fuel tank, or in a collector box or sump; the enclosed electric motor and the pump inlet are submerged in the fuel.

RESTRICTED

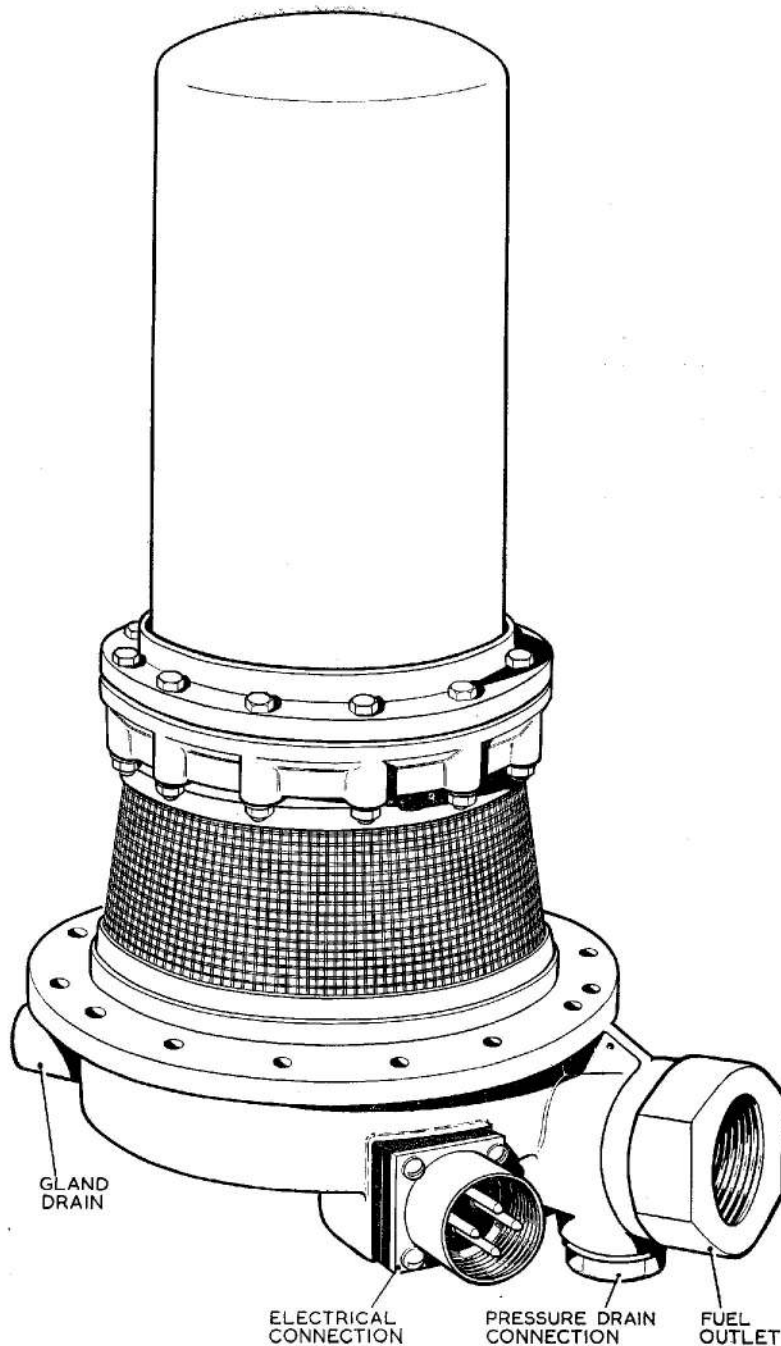

Fig. 1. External view of typical SPE.2009/SPE.2009A fuel pump

2. The motor unit is wired to allow two-speed operation, the speed being controlled by switching the shunt field so that at high speed the shunt field is open-circuited. There is a time limit on high speed operation of not more than a $\frac{1}{2}$ hour continuous running in a $1\frac{1}{2}$ hour period. The pump is fitted with a

network of radio interference noise suppressors, variations in this network constituting the difference between an SPE.2009 and an SPE.2009A pump.

3. Details of the differences between the mark numbers of each type, together with

RESTRICTED

the leading particulars, are given in the appendices to this chapter.

DESCRIPTION

4. The pump consists of three main sub-assemblies as follows:—

- (1) Pump base casting and by-pass valve assembly.
- (2) Upper base casting, incorporating the main gland preventing fuel access to the motor unit.
- (3) Motor unit.

Pump base

5. The circular flange of the lower base casting is provided with fourteen clearance holes for attachment of the pump to the tank stud ring. The lower base casting carries the delivery outlet, pressure fuel drain, gland drain, and electrical supply connections and is fitted with a protected motor breather inlet.

6. The lower half of a spiral delivery volute is cast into the pump base, the upper half being formed by a volute plate casting which spigots into the lower base casting. The centrifugal impeller system secured to the extended motor shaft, rotates within this volute. A by-pass flap valve, normally kept closed by pump delivery pressure, is mounted in the upper face of the volute plate, and allows fuel to by-pass the impeller system and flow directly into the outlet duct when the booster pump is idle.

Upper base

7. The upper base casting comprises mainly two circular end plates separated by two cored pillars, one of which serves as a conduit for the electrical leads and as a motor breather, the other serves as a gland drain. The lower end of the casting spigots into the pump base and is secured to studs.

8. The motor unit spigots into the upper base casting and a central housing contains the metallic bellows-type gland, which prevents fuel ingress into the electrical unit. The lower end of the casting houses the impeller helix which serves to separate any air and fuel vapour which may be evolved from the main fuel stream before they can pass into the centrifugal impeller and cause vapour

locking of the pump. A vapour guide cone fitted around the inlet to the helix, directs the air and fuel vapour out of the pump inlet. The inlet is completely surrounded by a wire mesh filter to prevent ingress of tank sediment and large particles of foreign matter into the impeller system.

Motor unit

9. The motor unit spigots into the upper base casting and is of laminated construction employing lap wound, short shunt, field connections. The yoke assembly is clamped between motor end casings, each of which houses a ball race to support the armature assembly. Each bearing is shielded, and pre-packed during manufacture with an anti-freeze/high melting point grease. They cannot be re-lubricated. The motor unit is flameproof and connected for two-speed operation (para. 2).

10. Brush gear is of unit construction to facilitate assembly. One brush per pole is fitted, each brush being slightly offset to produce a trailing angle to improve stability.

Thrower assembly

11. The inner race of the lower motor unit bearing is locked to the armature spindle by a labyrinth seal type thrower nut designed to throw off any slight fuel seepage past the main gland. A lapped carbon insert in this thrower nut forms the rotary member of the gland unit. Fuel seepage up the armature shaft is prevented by a sealing ring within the thrower nut.

12. The motor unit is totally enclosed in a flanged light alloy casing and is sealed against the ingress of fuel by a sealing ring secured by a clamping ring. Between the motor frame and this outer casing, a corrugated aluminium sleeve is fitted to assist with the dissipation of heat from the motor unit.

OPERATION

13. When the pump motor is energised, fuel from the tank is drawn into the eye of the helico-centrifugal impeller and then forced through the spiral volute in the pump base castings to the fuel outlet connection and to the delivery line.

RESTRICTED

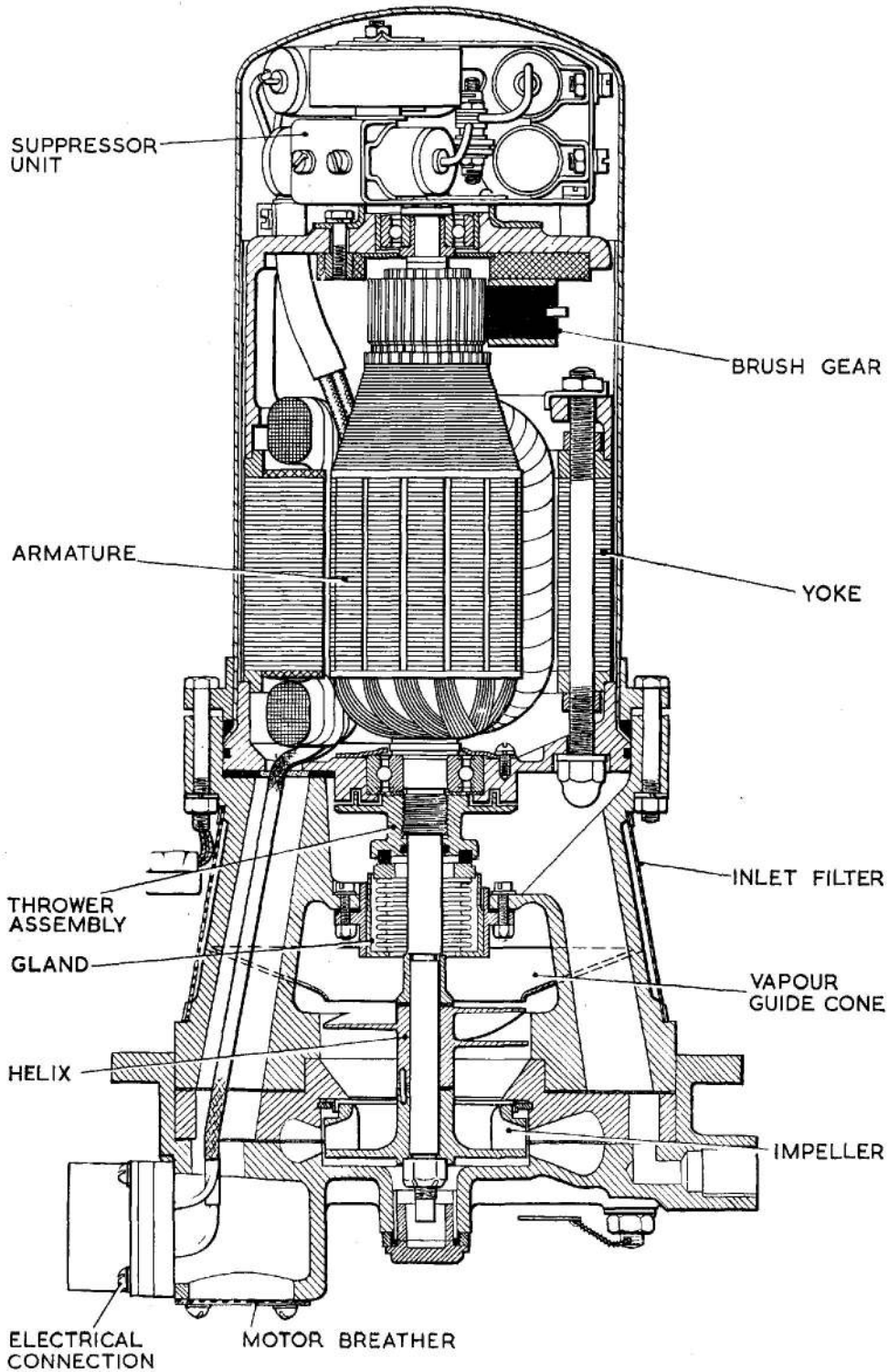

Fig. 2. Sectional view of typical SPE.2009 fuel pump

RESTRICTED

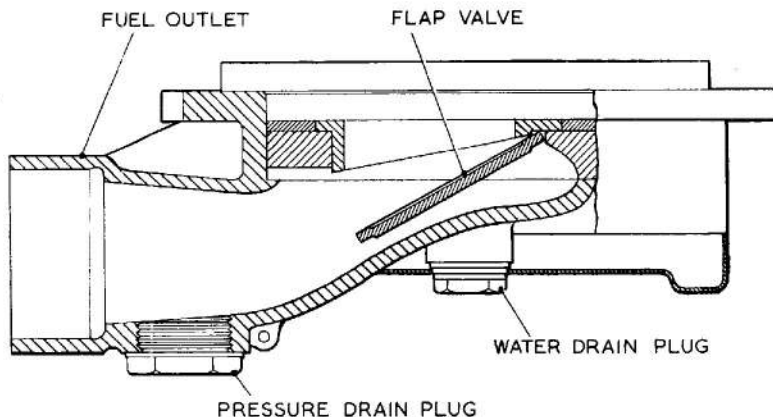

Fig. 3. Sectional view of pump fuel outlet

14. Under conditions in which the flow from the pump is low due to reduced engine requirements, the impellers continue to rotate at approximately normal speed without causing any excessive increase in fuel delivery pressure.

15. When the pump is idle, delivery pressure on the underside of the by-pass flap valve is relieved, allowing the valve to open and enabling the engine-driven pump to draw fuel direct from the tank and so maintain a pressure in the delivery line.

REMOVAL AND INSTALLATION

Removal

16. Before attempting to remove a pump, ensure that the tank has been drained of fuel and that the electrical supply to the pump has been switched off. The former can be checked by easing the water drain plug in the base of the pump, when, if there is any fuel remaining in the tank, it will have a free flow through the by-pass valve and volute passages of the pump to the drain plug.

17. The precise method of removing an SPE.2009 or SPE.2009A pump is detailed in the appropriate Aircraft Handbook. In general terms it will consist of disconnecting the fuel delivery pipe, the gland drain pipes and the electrical supply cable and plug from the pump socket. The pump can then be removed by releasing the fourteen nuts securing it to the tank stud ring. Support the weight of the pump during this operation.

Two $\frac{1}{2}$ in. B.S.F. screws can be used, if necessary, in the lower base casting tapped flange holes to assist in breaking the joint with the tank stud ring.

Pre-installation checks

18. The installation of all new pumps should be preceded by the following checks:—

(1) Ensure that the pump has not been stored for longer than the specified maximum period (i.e. 12 months in the original packing and carton as supplied by the manufacturer or 3 years where special packing has been provided). Pumps stored for periods in excess of these maxima must not be used without being first dismantled; examined and tested as detailed in Vol. 6.

(2) Inspect the exterior of the pump for evidence of damage, security of locking wires, general cleanliness and corrosion. Blend out small areas of corrosion and apply a protective finish (e.g. chromic acid solution) to the unprotected area.

(3) Check that transit plugs have been removed from the delivery outlet, gland drain and electrical connection and any tape or other protective material removed from the inlet filter and motor breather gauzes.

(4) It is advisable to make a starting check on the pump before installation. Apply a 26V d.c. electrical supply through the electrical connection. The pump must start immediately. Repeat

RESTRICTED

the test several times. If the pump fails to start immediately on any check it should be returned to an overhaul base for further serviceability testing using approved equipment.

Installation

19. The above pre-installation checks apply to all aircraft installations of these pumps. For detailed procedure covering the installation in a particular aircraft, reference should be made to the relevant Aircraft Handbook.

20. As a general example, installation in the aircraft will comprise the following operations:—

- (1) Fitting a new joint washer between the pump mounting flange and the tank stud ring, using an approved jointing compound on both sides of the washer.
- (2) Securing the pump with fourteen 2-B.A. nuts and lockwashers.
- (3) Reconnecting the fuel delivery and gland drain pipes, ensuring when relevant that the open end of the latter is in a low pressure area to prevent possible pressurisation during flight.
- (4) Reconnecting the electrical supply to the pump socket.
- (5) Wire locking all pipe connections, union nuts, etc.

SERVICING

Routine inspection

21. At routine inspections the following procedure applies:—

- (1) Inspect all the pipe connections and wire locking to the pump. Check the joint between the pump and the fuel tank for leakage. Correct as necessary.
- (2) Test the pump as detailed in para. 23-29. If the pump performance is found to be unsatisfactory in any way, the pump must be removed from the aircraft and a new or reconditioned unit fitted. No in-situ maintenance is possible.
- (3) Ensure that the by-pass valve is functioning correctly by completing relevant tests detailed in the appropriate Aircraft Handbook.
- (4) Ease the water drain plug and drain off any water which has separated in the fuel tank.

22. At the periods laid down in the appropriate Servicing Schedules, all pumps are to be replaced by new or reconditioned units drawn from stores. Faulty and time expired pumps must be returned to a Maintenance Unit or to the manufacturer for repair.

Electrical test

23. A routine electrical test in accordance with the appropriate Servicing Schedule should be made to ascertain that the motor unit is functioning satisfactorily. These tests must be made with the motor unit on load i.e. immersed in and pumping fuel. The pump must be replaced by a new or reconditioned unit if there is any indication of erratic performance, such as excessive current consumption.

'No fuel flow' test

Note . . .

The following 'no fuel flow' electrical test is only applicable to aircraft with the necessary instrumentation. Where no test panel is provided, particular attention should be paid to the Electrical test (para. 23) and Operational test (para. 27).

24. Ascertain the position of the aircraft pump test socket and switches by reference to the relevant Aircraft Handbook. Proceed as follows:—

- (1) Close all fuel cocks between the pump and engine to ensure that no fuel can flow.
- (2) Connect a suitable portable ammeter to the socket on the test panel.

Note . . .

When using a clip-on type ammeter the tongs should be opened and closed smartly prior to use to reduce the hysteresis error.

- (3) Switch on the pump by depressing the switch on the test panel. Observe the ammeter reading for a period of not less than 30 seconds.

25. Interpret the readings obtained as follows:—

- (1) A steady reading not exceeding that indicated by the graph (Fig. 4) for the measured applied voltage, indicates that the motor unit is functioning satisfactorily.

RESTRICTED

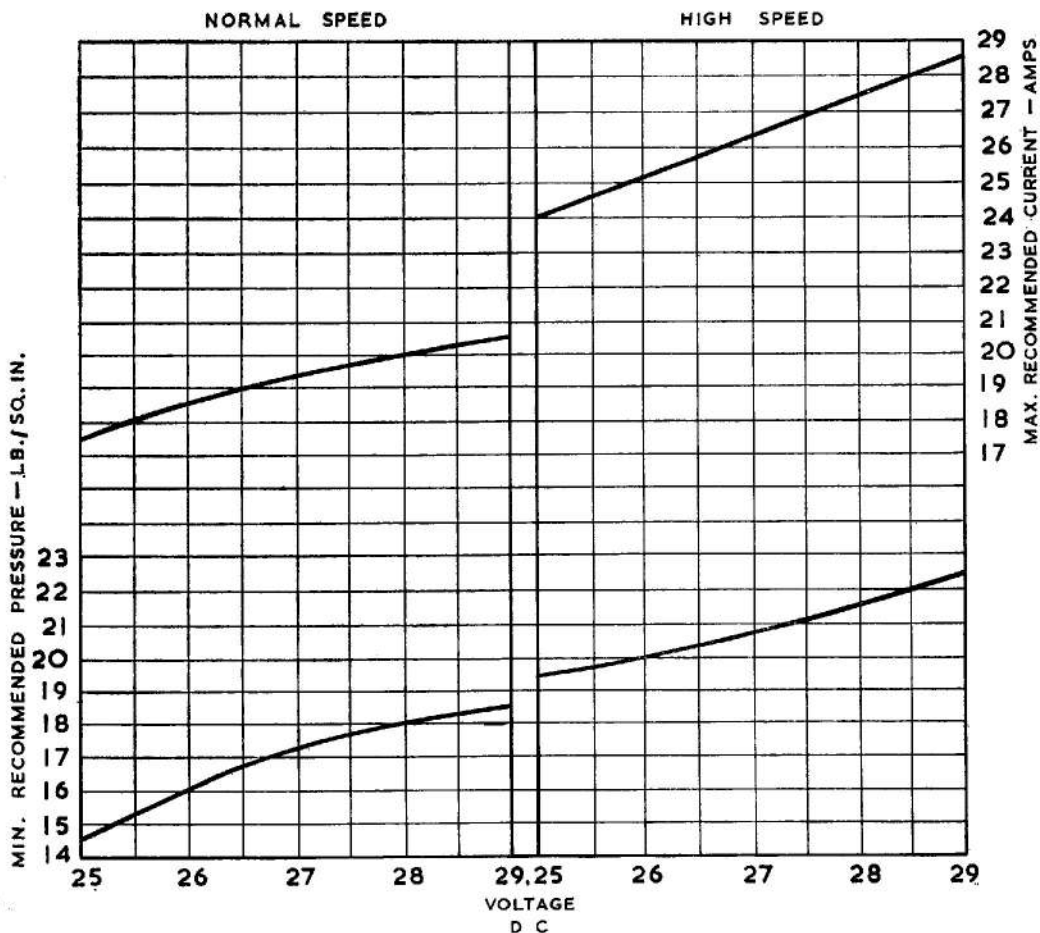

Fig. 4. "No fuel flow" electrical test graph

Note . . .

The graph (fig. 4) is provided as a general guide to the pump performance under no-flow conditions. The figures derived from it are not to be interpreted as forming a part of the approved Acceptance Test Specification of the pump.

(2) Current consumption in excess of the graph reading indicates either a faulty motor unit, a rise in torque loading due to the obstruction of moving parts, or a restriction of the fuel flow.

(3) A fluctuating reading indicates faulty contacts, defective brushes, faulty commutation or that bearings or other rotating parts are binding.

(4) A zero reading indicates an open circuit and is consistent with a blown fuse, defective switch, faulty wiring or a complete motor failure.

26. When the above tests have been completed satisfactorily, release the test switch and disconnect the ammeter.

Operational test

27. Subject to the electrical test being completed satisfactorily, the pump should be tested where the installation permits for proof of performance, and checked against the performance figures quoted in the appropriate appendix to this chapter. Refer to the relevant Aircraft Handbook for procedure details. Possible causes of failure, to obtain the required performance are given in Table 1.

RESTRICTED

Gland leakage test

28. During the above tests an examination should be made of the gland drain exit for fuel leakage. The leakage must not exceed a rate of 2 c.c. per hour with the pump running and 1 c.c. per hour with the pump stationary. Any leakage in excess of these figures will necessitate removal of the pump from the aircraft.

Insulation resistance test

29. Using a 250 Volt constant pressure insulation resistance tester measure the insulation resistance between the socket pins and earth. When a new pump is drawn from stores the insulation resistance must not be less than 2 megohms. After installation, due to the humidity conditions prevalent in aircraft at dispersal points, the minimum permissible insulation resistance is 50,000 ohms.

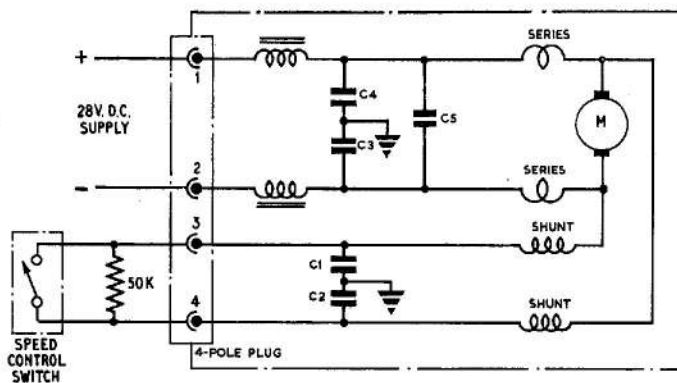

Fig. 5. Circuit diagram, SPE.2009

TABLE 1
Faults, possible causes and rectification

Fault	Possible cause	Rectification
Gland leakage	(1) Bad finish between gland seal faces. (2) Insufficient pressure between gland seal faces.	All these conditions require that the pump is removed from the aircraft and returned to a Maintenance Unit or to the pump manufacturer for reconditioning.
Excessive current	(1) Excessive loading on metallic bellows gland. (2) Faulty motor unit. (3) Fouling of impeller by foreign matter.	
Low delivery pressure	(1) Faulty motor.	All these conditions require that the pump is removed from the aircraft and returned to a Maintenance Unit or to the pump manufacturer for reconditioning.
Pressure surge	(1) Tight or pre-loaded bearings. (2) Excessive loading on metallic bellows gland.	
Low insulation resistance	Dampness in motor windings.	

RESTRICTED

Appendix 1

PUMPS, FUEL, SPE.2009 MK. 4, MK. 5, MK. 6 and MK. 7

Pump, fuel, Type SPE.2009 Mk.4	Ref 5UE/6622
Pump, fuel, Type SPE.2009 Mk.5	Ref 5UE/6878
Pump, fuel, Type SPE.2009 Mk.6	Ref 5UE/7516
Pump, fuel, Type SPE.2009 Mk.7	Ref 5UE/7582
Voltage limits	25.0/29.0V d.c.
Rated voltage	26.0V d.c.
Rated output at 26V d.c. (Normal speed)	1,000 gal./hr.
Rated output at 26V d.c. (High speed)	2,000 gal./hr.
Min. delivery pressure at rated output/voltage (Normal speed)	14 lb./in ² .
Min. delivery pressure at rated output/voltage (High speed)	12.5 lb./in ² .
Maximum current consumption at rated output/voltage (Normal speed)	18.0A.
Maximum current consumption at rated output/voltage (High speed)	25.0A.
Maximum no-flow delivery pressure at 29.0V d.c. (High speed)	28 lb./in ² .
Minimum no-flow delivery pressure	See Fig. 4, basic chapter.
Electrical connection (Plessey 2CZ.111228)	Ref. No. 5X/7154
Delivery outlet tapping	1½ in. B.S.P.
Gland drain tapping	¼ in. B.S.P.
Weight of unit	approx. 14.5 lb.

Type differentiation

1. Basic differences between the various marks of SPE.2009 series pumps covered by this appendix are as follows :—

SPE.2009 Mk.4

Basic design covered in this chapter.

SPE.2009 Mk.5

Generally similar to Mk.4 pump but the method of mounting the upper and lower motor unit bearings improved to give increased component lives (see Mk.7 below).

SPE.2009 Mk.6

Generally similar to the Mk.5 pump but the base cover deleted to facilitate accessibility to the to the base casting securing nuts during maintenance.

SPE.2009 Mk.7

Generally similar to the Mk.6 pump but felt sealed bearings fitted and bearing abutments of the armature spindle modified.

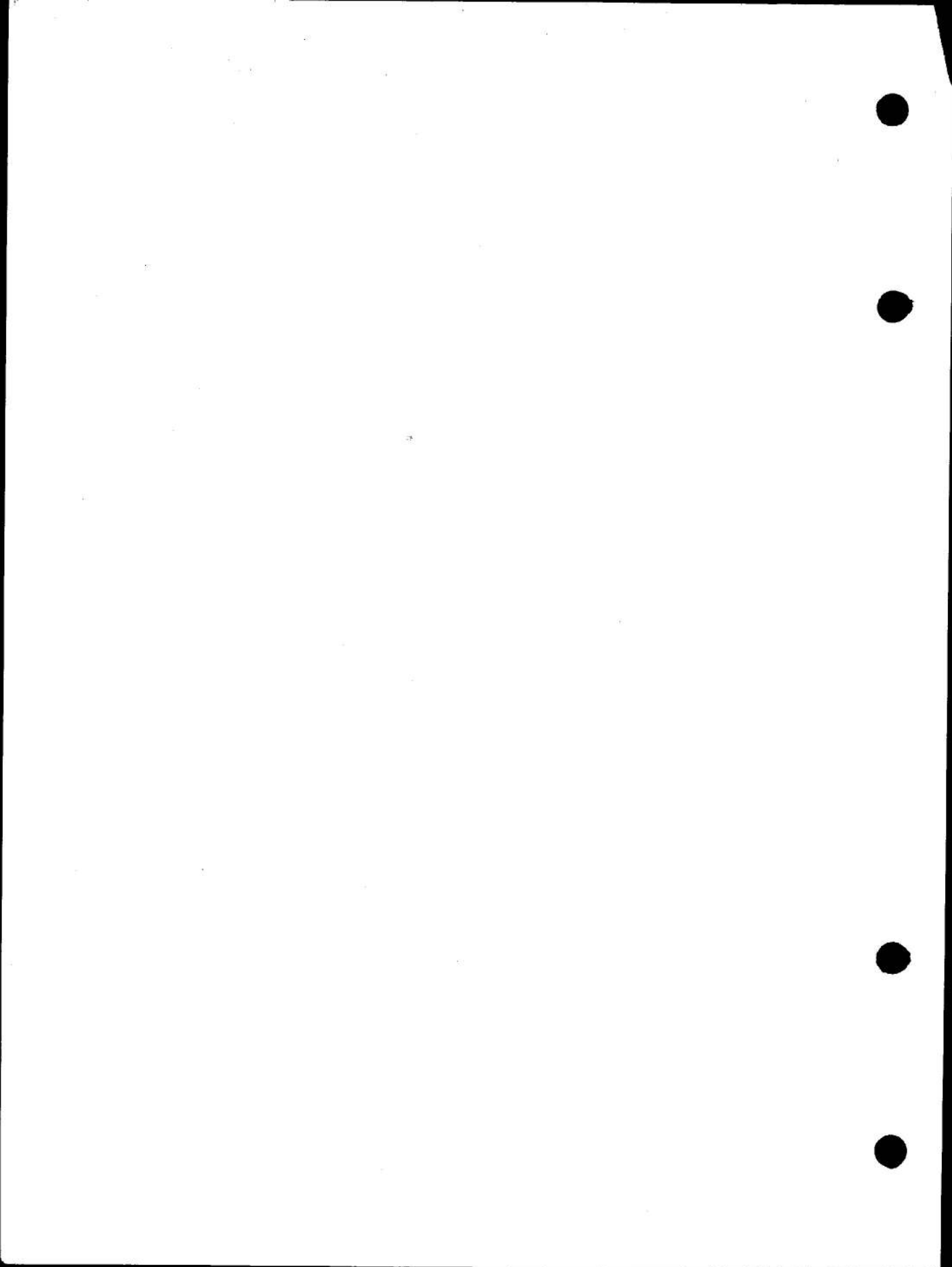

Appendix 2

PUMPS, FUEL, SPE.2009A MK. 4, MK. 5, MK. 6 and MK. 7

Pump, fuel, Type SPE.2009A Mk.4	Ref. 5UE/
Pump, fuel, Type SPE.2009A Mk.5	Ref. 5UE/6882
Pump, fuel, Type SPE.2009A Mk.6	Ref. 5UE/7517
Pump, fuel, Type SPE.2009A Mk.7	Ref. 5UE/7583
Voltage limits	25.0/29.0V d.c.
Rated voltage	26V d.c.
Rated output at 26V d.c. (Normal speed)	1,000 gal./hr.
Rated output at 26V d.c. (High speed)	2,000 gal./hr.
Min. delivery pressure at rated output/voltage (Normal speed)	14 lb./in ² .
Min. delivery pressure at rated output/voltage (High speed)	12.5 lb./in ² .
Maximum current consumption at rated output/voltage (Normal speed)	18.0A.
Maximum current consumption at rated output/voltage (High speed)	25.0A.
Maximum no-flow delivery pressure at 29.0V d.c. (High speed)	28 lb./in ² .
Minimum no-flow delivery pressure	See Fig. 4, basic chapter.
Electrical connection (Plessey 2CZ.111228)	Ref. No. 5X/7154
Delivery outlet tapping	1½ in. B.S.P.
Gland drain tapping	¼ in. B.S.P.
Weight of unit	approx. 14.5 lb.

Introduction

1. The SPE.2009A fuel pump is basically similar to the SPE.2009 pump apart from the radio noise suppression network fitted internally on the top casing of the motor unit.

upper and lower motor unit bearings improved to give increased component lives (see Mk.7 below).

Type differentiation

2. Basic differences between the various marks of SPE.2009A series fuel pumps covered by this appendix are as follows:—

SPE.2009A Mk.4

Basic design covered by this chapter.

SPE.2009A Mk.6

Generally similar to the Mk.5 pump but the base cover deleted to facilitate accessibility to the base casting securing nuts during maintenance.

SPE.2009A Mk.5

Generally similar to the Mk.4 pump but the method of mounting the

SPE.2009A Mk.7

Generally similar to the Mk.6 pump but felt sealed bearings fitted and the bearing location abutments of the armature spindle modified.

RESTRICTED

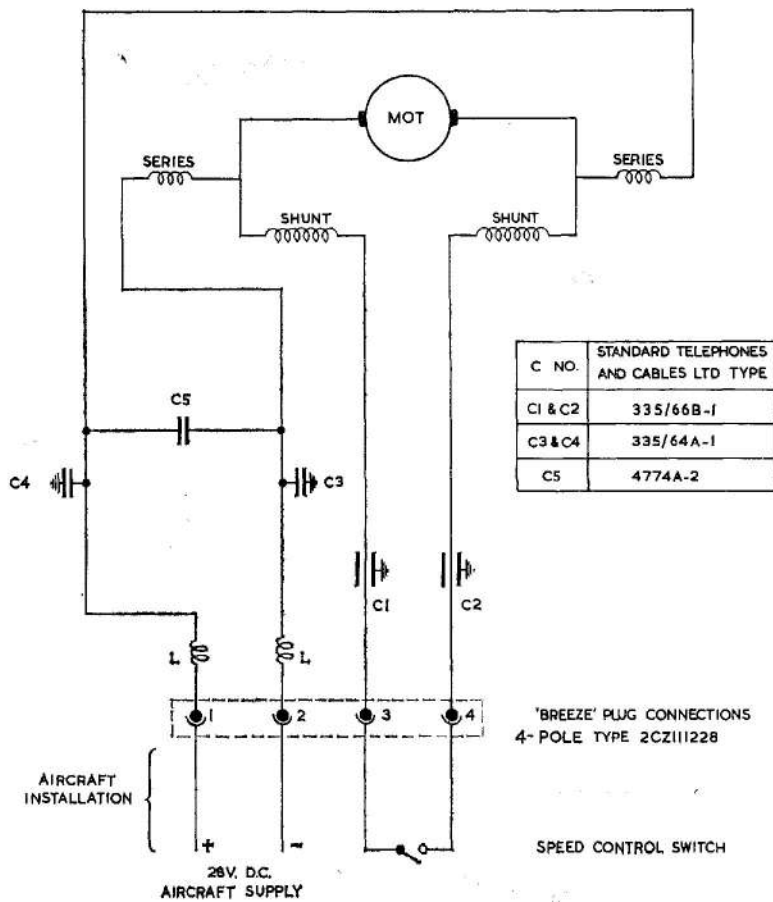

SUPPLY POLES 1 AND 2
FOR NORMAL SPEED CONNECT 3 AND 4
FOR HIGH SPEED OPEN 3 AND 4

Fig. 1. Circuit diagram, SPE.2009A

RESTRICTED

This file was downloaded from the RTFM Library.
Link: www.scottbouch.com/rtfm

Please see site for usage terms, and more aircraft documents.

