

Chapter 47

PUMP, FUEL, SPE.352

LIST OF CONTENTS

	Para.		Para.
<i>Introduction</i>	1	Removal and installation	
Description		<i>Removal</i>	10
<i>General</i>	3	<i>Pre-Installation checks</i>	12
<i>Impeller system</i>	4	<i>Installation</i>	13
<i>Bearings</i>	5	Servicing	
<i>Motor unit</i>	6	<i>Routine inspection</i>	15
<i>Electrical connection</i>	7	<i>Electrical test</i>	17
Operation	8	<i>Operational test</i>	21
		<i>Gland leakage</i>	22
		<i>Insulation resistance test</i>	23

LIST OF ILLUSTRATIONS

	Fig.
<i>External view of typical SPE.352 fuel pump</i>	1
<i>Sectional view of SPE.352, Mk. 4A fuel pump</i>	2
<i>'No fuel flow' electrical test graph</i>	3
<i>Circuit diagram</i>	4

LIST OF TABLES

	Table
<i>Faults, possible causes and rectification</i>	1

LIST OF APPENDICES

	App.
<i>Pump, fuel, Type SPE.352 Mk. 4A</i>	1

RESTRICTED

Introduction

1. Type SPE.352 fuel transfer or booster pumps are electrically driven and mounted wholly within the aircraft fuel tank. The particular application for the pump detailed in this chapter is as a transfer pump for fuel from a wing pod tank to the main fuel tank.
2. The pump is of the right-angle drive type to suit installations where the fuel tank depth is restricted, and is bolted to a cast mounting plate secured to a stud ring in the base of the tank. The electrical connection to the pump motor is through a special fuel tight socket on the pump casting.

Impeller system

4. The two stage impeller system comprises a helical impeller surmounted by a centrifugal impeller, the latter closely contained within a spiral volute casting bolted to the base of the pump body. A vapour guide cone works in conjunction with the helical impeller in separating any air bubbles and fuel vapour, which may be evolved, before they reach the centrifugal impeller. A short elbow attached to the open end of the spiral volute forms an outlet to which the delivery line is connected (within the fuel tank).

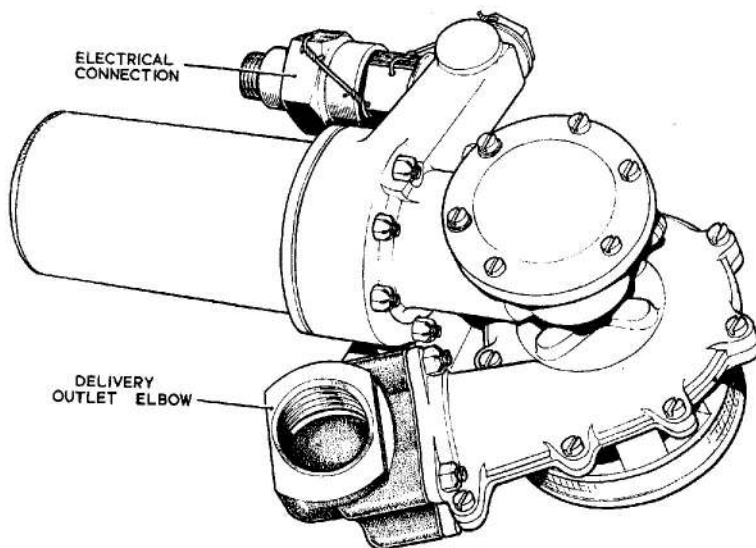

Fig. 1. External view of typical SPE.352 fuel pump

DESCRIPTION

General

3. A typical SPE.352 pump is illustrated in Fig. 2. Basically the unit consists of a pump unit spindle mounted vertically in the main pump casting and driven through right angle reduction gearing, by a horizontally mounted pump motor. A metallic bellows unit fitted into the pump casting and a carbon seal seat in the upper face of the centrifugal impeller, together form a gland preventing ingress of fuel into the gear chamber and the motor unit. Any leakage of fuel past this gland is led away to the circular mounting boss of the pump where connection is made to a drain pipe to atmosphere.

Bearings

5. The pump spindle is supported at its upper end in a shielded ball race and at its lower end in a plain carbon bearing which is lubricated by the fuel. Motor bearings are of the shielded type and both pump and motor ball races are pre-packed during manufacture with an anti-freeze/high melting point grease and cannot be re-lubricated.

Motor unit

6. The motor is of conventional design, being a totally enclosed, 2 pole, compound wound machine, spigot mounted to the side of the pump body and clamped in position. The extended armature shaft carries a bevel pinion which engages the larger bevel gear of the pump unit spindle. These gears are contained within a gear chamber at the top

RESTRICTED

of the pump unit, which is pre-packed on assembly with sufficient grease for the normal life of the pump.

Electrical connection

7. Electrical connection to the motor is by a special two-pole socket and plug assembly mounted on the pump casting. The socket assembly is normally assembled on to the aircraft conduit which carries the aircraft supply cables. The connection is within the fuel tank and sealed against ingress of fuel.

OPERATION

8. Fuel from the tank enters the pump through a wire mesh filter into the underside of the impeller helix which is driven by the motor through right-angle bevel gearing. The fuel stream is drawn into the centrifugal impeller from which it is forced into the volute and through the pump outlet into the delivery line. Air and fuel vapour evolved during flight are separated by the action of the impeller helix in conjunction with a vapour guide cone before it enters the centrifugal impeller.

9. Under conditions in which the flow from the pump is low due to reduced engine requirements, the impeller continues to rotate at approximately normal speed without causing any excessive increase in fuel delivery pressure. A by-pass valve is not fitted to this design of pump.

REMOVAL AND INSTALLATION

Removal

10. Before attempting to remove a pump, ensure that the tank has been emptied of fuel and that the electrical supply to the pump has been switched off. The latter can be checked by easing the drain valve in the fuel tank or pump mounting plate.

11. The exact method of removing an SPE.352 pump is detailed in the appropriate Aircraft Handbook. In general terms it will comprise disconnecting any gland drain pipe fitted and removing the nuts securing the mounting plate to the tank stud ring, taking care to support this plate as both electrical and fuel delivery pipe connections to the pump are made within the tank. Dis-

connect the fuel delivery pipe and electrical supply conduit at the pump. The four bolts securing the pump to the mounting plate can then be removed.

Pre-installation checks

12. The installation of all new pumps should be preceded by the following checks :—

(1) Ensure that the pump has not been stored for longer than the specified maximum period of 12 months in its original packing and carton as supplied by the manufacturer, or 3 years where special packing has been provided. Pumps stored for periods in excess of these limits must not be used without being dismantled and tested as detailed in Vol. 6.

(2) Inspect the exterior of the pump for damage, security of locking wires, general cleanliness and corrosion. Blend out slight areas of corrosion and apply an approved protective finish (Chromic acid solution) to the unprotected area.

(3) Check that transit plugs have been removed from the delivery outlet and electrical connections and that any tape or other protective material has been removed from the inlet filter, and from the motor breather gauze and gland drain pipe on the underside of the mounting boss.

(4) It is advisable to make a starting check on the pump before installation. Apply a 26V d.c. electrical supply through the electrical connection. The pump must start immediately. Repeat the test several times. If the pump fails to start immediately it should be returned to an overall base for further serviceability testing using approved equipment.

Installation

13. The above pre-installation checks apply to all aircraft installations of these pumps. For detailed procedure relating to installation in a particular aircraft, reference should be made to the relevant Aircraft Handbook.

14. As a general example, installation in the aircraft will comprise the following operations :—

RESTRICTED

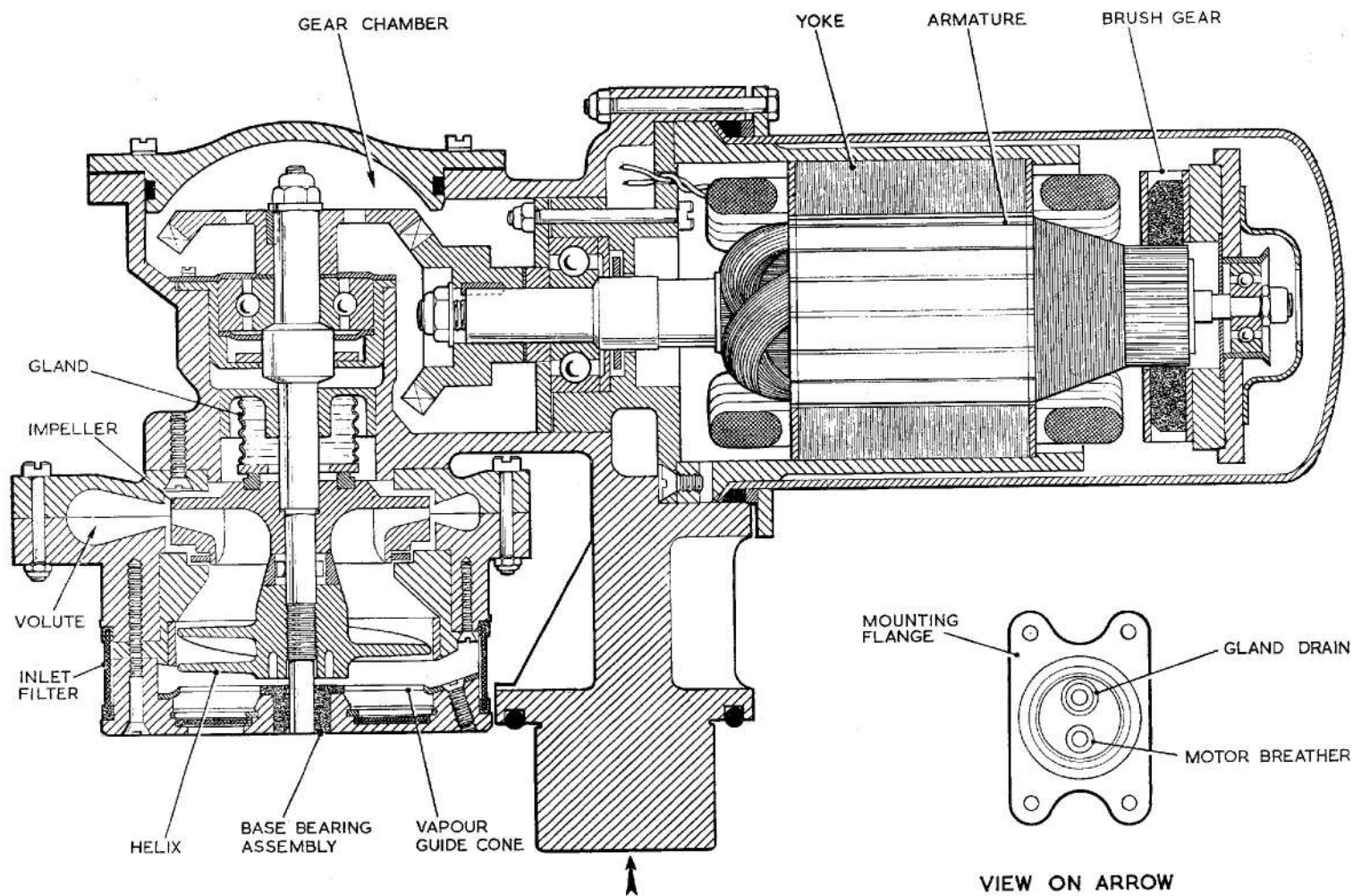

Fig. 2. Sectional view of SPE.352, Mk.4A fuel pump

- (1) Fit a new seal ring in the groove under the mounting flange.
- (2) Bolt the pump to the tank mounting plate. Wire lock the bolts.
- (3) Support the pump and mounting plate assembly below the tank aperture. Reconnect the fuel delivery hose and electrical supply conduit to the delivery outlet adapter and pump socket respectively. Wire lock the connections.
- (4) Check that the pump mounting plate is clean and that any drain valve fitted is closed. Renew any sealing ring in the mounting plate, sealing it in accordance with the instructions in the relevant Aircraft Handbook. Bolt the mounting plate to the tank, refill the tank and check for leaks.

SERVICING

Routine inspection

15. At routine inspection the following procedure applies:—

- (1) Inspect the tank mounting plate joint for leakage. Correct as necessary.
- (2) Test the pump as detailed in para. 17-23. If the pump performance is found to be unsatisfactory in any way, the pump must be removed from the aircraft and a new or reconditioned unit fitted. No in-situ maintenance is possible.

16. At the periods laid down in the appropriate Servicing Schedules, all pumps are to be replaced by new or reconditioned units drawn from Stores. Faulty and time expired pumps must be returned to a Maintenance Unit or to the pump manufacturer for repair and reconditioning.

Electrical test

17. A routine electrical test in accordance with the appropriate Servicing Schedule should be made to ascertain that the motor unit is functioning satisfactorily. These tests must be made with the motor unit on load i.e. immersed in and pumping fuel. The pump must be replaced by a new or reconditioned unit if there is any indication of erratic performance such as excessive current consumption.

'No fuel flow' test

Note . . .

The following 'no fuel flow' electrical test is only applicable to aircraft with the necessary instrumentation. Where no test panel is provided, particular attention should be paid to the Electrical test (para. 17) and Operational test (para. 21).

18. Ascertain the position of the aircraft pump test socket and switches by reference to the relevant Aircraft Handbook. Proceed as follows:—

- (1) Close all fuel cocks between the pump and main tanks (transfer pumps) or engine (fuel booster applications) to ensure that no fuel can flow.
- (2) Connect a suitable portable ammeter to the socket on the test panel.

Note . . .

When using a clip-on type ammeter the tongs should be opened and closed smartly prior to use to reduce the hysteresis error.

- (3) Switch on the pump by depressing the switch on the test panel. Observe the ammeter reading for a period of not less than 30 seconds.

19. Interpret the readings obtained as follows:—

- (1) A steady reading not exceeding that indicated by the graph (fig. 3) for the measured applied voltage, indicates that the motor unit is functioning satisfactorily.

Note . . .

The graph (fig. 3) is provided as a guide to pump performance under no-flow conditions: the figures derived from it are not to be interpreted as forming a part of the approved Acceptance Test Specification for the pump.

- (2) Current consumption in excess of the graph reading indicates either a faulty motor unit, a rise in torque loading due to the obstruction of moving parts, or a restriction of fuel flow.
- (3) A fluctuating reading indicates faulty contacts, defective brushes, faulty commutation or that bearings or other rotating parts are binding.
- (4) A zero reading indicates an open circuit and is consistent with a blown

RESTRICTED

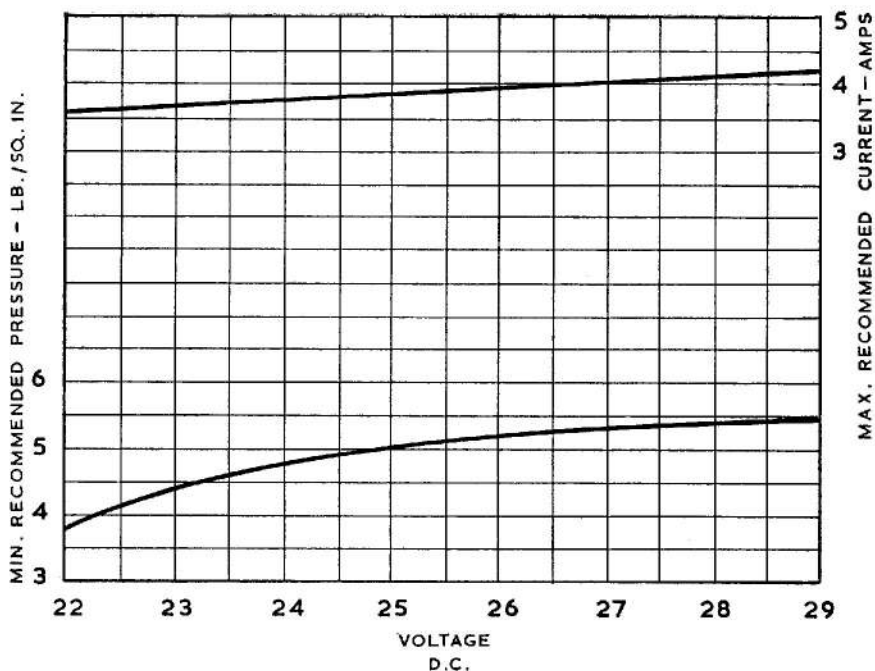

Fig. 3. "No fuel flow" electrical test graph

fuse, defective switch, faulty wiring or a complete motor failure.

20. When the above tests have been completed release the test switch and disconnect the ammeter.

Operational test

21. Subject to the electrical test being completed satisfactorily, the pump should be tested where aircraft instrumentation permits for proof of performance and checked against the rated performance figures quoted in the appropriate appendix to this chapter. Refer to the relevant Aircraft Handbook for procedure details. Possible causes of failure, to meet the required performance, are given in Table 1.

Gland leakage

22. During the above tests an examination should be made of the gland drain exit for fuel leakage. The leakage must not exceed two drops per minute while the pump is running, or, one drop per minute while it is stationary. Any leakage in excess of these figures will necessitate the removal of the pump from the aircraft.

Insulation resistance test

23. Using a 500 volt insulation resistance tester, measure the insulation resistance between the socket pins of the external tank/pump electrical connection and earth. When a new pump is drawn from stores the insulation resistance must be not less than 2 megohms. After installation, due to humidity conditions prevalent in aircraft at dispersal points, the minimum permissible insulation resistance is 50,000 ohms.

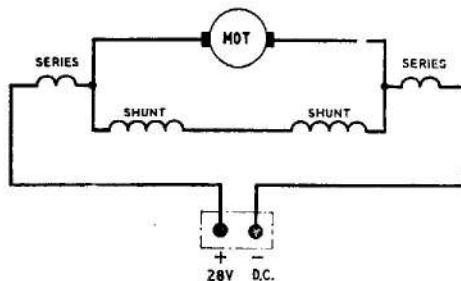

Fig. 4. Circuit diagram

TABLE 1**Faults, possible causes and rectification**

Fault	Possible cause	Rectification
Gland leakage	(1) Bad finish between gland seal faces. (2) Insufficient pressure between gland seal faces.	All these conditions require that the pump is removed from the aircraft and returned to a Maintenance Unit or to the pump manufacturer for reconditioning.
Excessive current	(1) Excessive loading on metallic bellows gland. (2) Faulty motor unit. (3) Fouling of impeller by foreign matter.	
Low delivery pressure	(1) Faulty motor unit.	
Pressure surge	(1) Tight or pre-loaded bearings. (2) Excessive loading on metallic bellows gland.	
Low insulation resistance	(1) Dampness in motor windings.	

RESTRICTED



Appendix 1

PUMP, FUEL, TYPE SPE.352 MK. 4A

Pump, fuel, Type SPE.352 Mk. 4A	Ref. No. 5UE/7057
<i>Voltage limits</i>	22.0/28.8V d.c.
<i>Rated voltage</i>	24.0V d.c.
<i>Rated output at 24.0V d.c.</i>	350 gal./hr.
<i>Min. delivery pressure at rated output/voltage (AVTUR)</i>	3.5 lb./in ² .
<i>Min. delivery pressure at rated output/voltage (Pool distillate)</i>	3.4 lb./in ² .
<i>Maximum current consumption at rated output/voltage (AVTUR)</i>	3.7A
<i>Maximum current consumption at rated output/voltage (Pool distillate)</i>	3.6A
<i>Maximum no-flow delivery pressure at 28.8V d.c. (AVTUR)</i>	4.2A
<i>Maximum no-flow delivery pressure at 28.8V d.c. (Pool distillate)</i>	4.1A
<i>Minimum no-flow delivery pressure</i>	See Fig. 3, basic chapter.
<i>Electrical connection</i>	2-pin special
<i>Delivery outlet</i>	Internal tank
<i>Gland drain tapping</i>	Special
<i>Weight of unit</i>	5.25 lb.

RESTRICTED

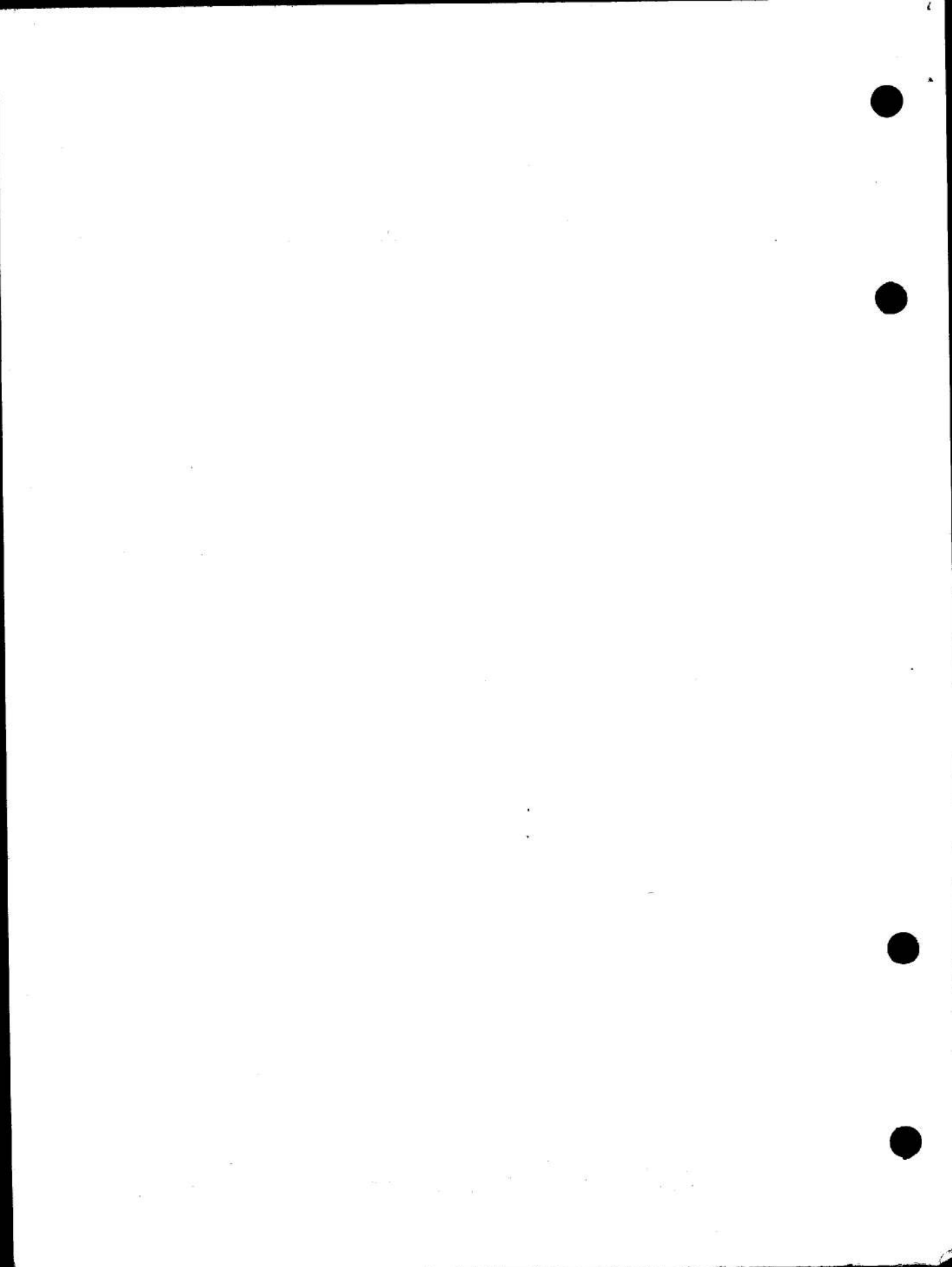

This file was downloaded
from the RTFM Library.
Link: www.scottbouch.com/rtfm
Please see site for usage terms,
and more aircraft documents.

