

Chapter 8

PUMP, FUEL, PUL 403, Mk. 1

LIST OF CONTENTS

	Para.		Para.
Introduction	1	By-pass valve	10
Description	2	Filter	11
Motor	4	Operation	12
Portway casting assembly	5	Installation	16
Impeller	6	Servicing	
Vapour deflector	7	Electrical test	21
Flexibox fuel sealing gland	8	Operational test	24
Pump base assembly	9	Routine inspection	25

LIST OF ILLUSTRATIONS

	Fig.		Fig.
General view of PUL 403, Mk. 1 fuel pump	1		
Sectional view of PUL 403, Mk. 1 fuel pump	2	Circuit diagram	3

LEADING PARTICULARS

Pump, fuel, PUL 403, Mk. 1	Stores Ref. 5UE/5639
Operating voltage	24 volts d.c.
Normal current	8 amp.
Delivery rate	400 gallons per hour
Delivery pressure	10 lb. per sq. in.
Weight	8½ lb.
Aviation gasoline	100/130 Octane

Introduction

1. The PUL 403, Mk. 1 fuel pump is designed for vertical mounting in the base of aircraft fuel tanks, fuel collector box, or sump. The pump is electrically driven, and self contained, operating at 24 volts d.c., and is intended primarily for use as a booster pump, to maintain the fuel supply to the engine driven pump under all conditions of fuel temperature, rate of climb, altitude, etc., which can be experienced in flight. When in service the body of the pump is inserted through a suitable reinforced aperture in the fuel tank, and is secured in position by bolting the flange of the pump base to the bottom of the tank.

F.S./1

DESCRIPTION

2. A sectional view of the pump is shown (*fig. 2*), and consists mainly of a driving motor, supported in the upper end of the pump body, or portway casting, which in turn is secured to the pump base assembly. A paper washer is provided as a joint, together with a Hermetical Wellseal jointing compound, between the upper face of the pump base, and the portway casting. Fourteen $\frac{7}{32}$ in. clearance holes, equally spaced around the flange, permit the pump to be bolted to the fuel tank, into which the body of the pump extends. Two $\frac{1}{4}$ in. B.S.F., tapped holes, diametrically opposite

(A.L. 1, July 57)

RESTRICTED

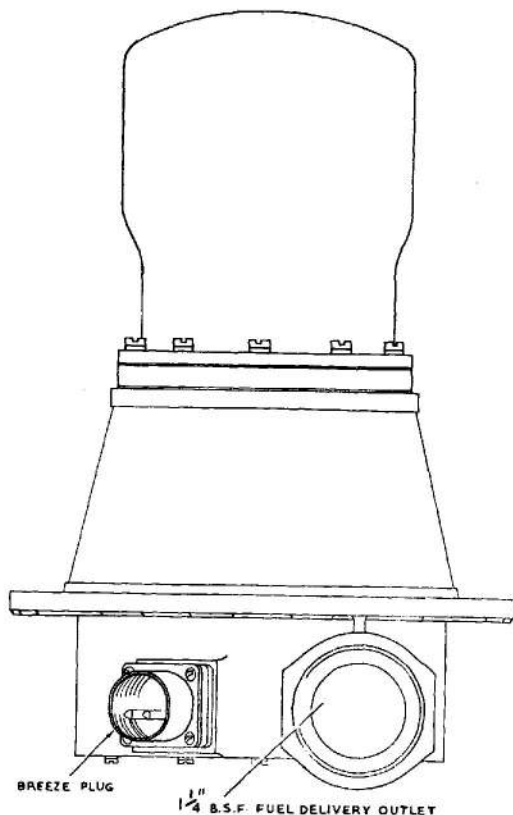

Fig. 1. General view of PUL 403, Mk. I fuel pump

in the flange, assist in breaking the joint, when it is necessary to remove the pump from the tank.

3. The motor casing, which is completely immersed in fuel, is hermetically sealed, to prevent the ingress of fuel. The motor armature shaft, or, impeller spindle, extends downwards through the portway casting and flexibox fuel sealing gland. The pump impeller is fitted to the lower end of the armature shaft, and is secured by a self-locking nut. The impeller is positioned within the volute chamber, formed by the portway and base castings.

Motor

4. The motor, which is a totally enclosed, compound wound, two pole machine, is of the fan cooled type, inlet and outlet passages being cored in the pump castings and yoke. A gauze air screen is fitted to the bottom of the pump base casting to prevent foreign matter from the atmosphere being drawn into the motor, it also serves as a fire screen, thus preventing flames from damaging the

interior of the pump. The motor armature rotates in ball bearings, the upper bearing being secured to the shaft by a pinnacle nut, whilst the lower bearing is secured to the shaft by a special shaped nut which serves as a thrower ring. The upper bearing is housed in the motor inner casing, between the brush-box retainer and the brush-box, whilst the lower bearing is housed in the motor casing base-plate. The base-plate is flanged, to permit the accurate location in the end of the motor casing, and is provided with three elongated holes. Two of these holes provide ventilation for the motor, and the third hole serves as an entry for the electrical supply leads to the motor.

Portway casting assembly

5. The pump body, more familiarly known as the portway casting, upon which the motor is mounted, comprises two circular flanged ends, separated by cored out pillars. These cored out pillars serve as (1) a conduit for the electrical supply leads to the motor, (2) ventilation, to prevent the motor overheating, and (3) as a drain duct, from the space between the motor lower bearing, and the upper surface of the flexibox fuel sealing gland. When the pump is assembled, a flared cone, known as a vapour deflector, is fitted on the motor shaft extension, immediately below the flexibox gland. A three section vapour guide cone, located around the mouth of the impeller chamber, is designed to carry away accumulations of fuel vapour and air, developed during high rates of climb to altitude.

Impeller

6. The impeller, which is designed for operation at high altitudes, is of the top entry type, and particular care has been exercised during manufacture in smoothing the suction passages, to prevent undue disturbances of the fuel passing through the pump.

Vapour deflector

7. A conical vapour deflector is mounted immediately above the impeller eye, to lead away any vapour separated from the fuel by the impeller.

Flexibox fuel sealing gland

8. This type of fuel sealing gland is an improvement on the metallic bellows gland, its sealing qualities being based on a carbon

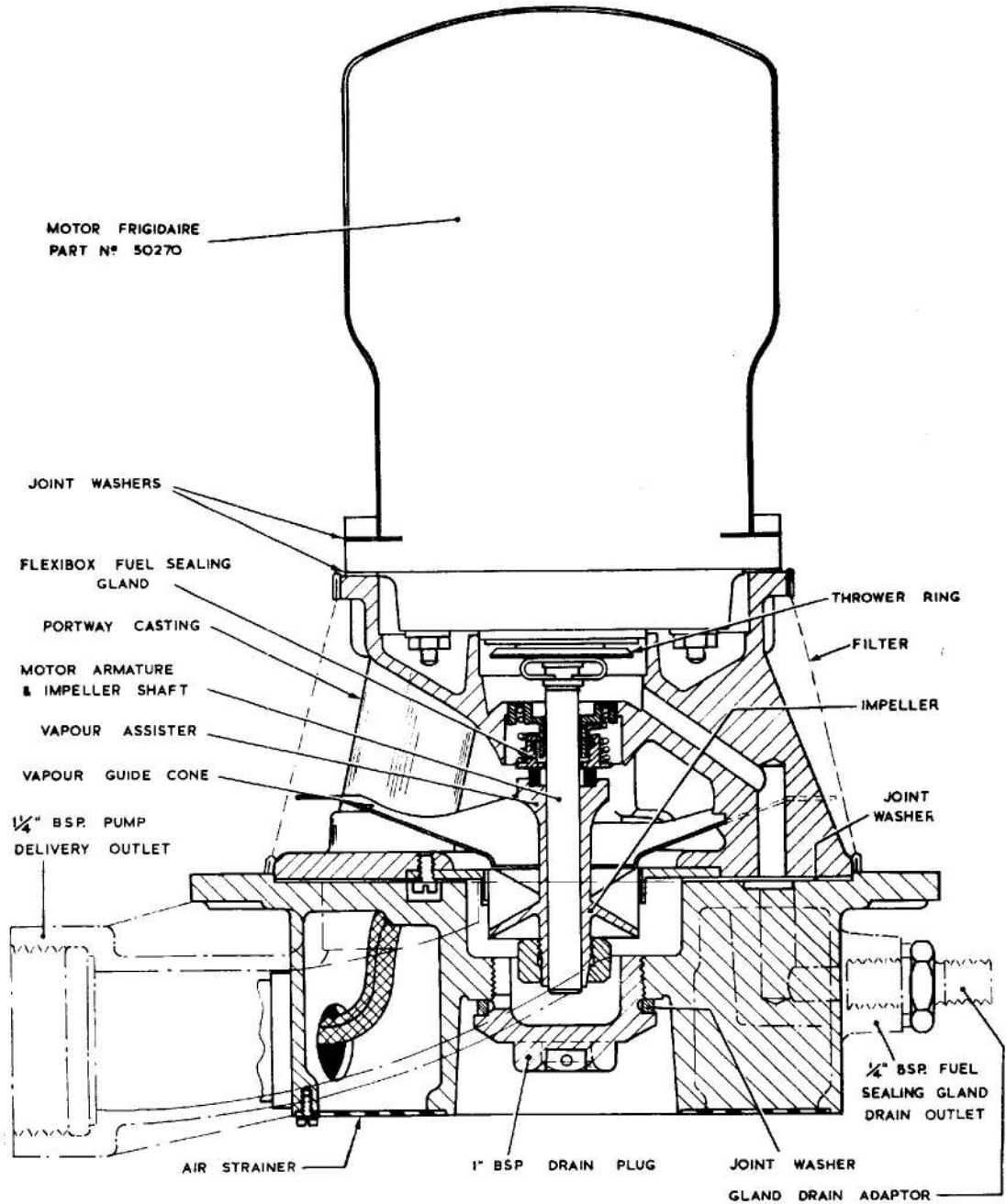

Fig. 2. Sectional view of PUL 403, Mk. I fuel pump

ring, secured to the rotating impeller sleeve. The carbon ring rubs against a stationary stainless steel, lapped face, held by a spring at a pre-determined pressure.

Pump base assembly

9. The pump base is a casting, in which is formed a volute chamber, leading to the fuel pump outlet. A machined boss, adjacent to the outlet, provides a seating for a two-pole Breeze type plug, which is the location for the electrical connection for the input leads to the motor. Fitted to the other side of the pump outlet is the $\frac{1}{4}$ in. B.S.P. tapped hole, which is the exit for the gland drain duct. A 1 in. B.S.P. threaded plug, located centrally in the underside of the pump base, allows any accumulations of water to drain from the fuel tank, without having to remove the pump.

By-pass valve

10. The by-pass valve is located in a recess, cast in the pump base, and is clamped in position, when the portway casting is mated to the pump base. The valve is hinged to an annular seating, just above the fuel delivery outlet. During the operation of the pump, the pressure of fuel passing through the pump delivery outlet, prevents the valve from opening, but is open, due to the resultant drop in pressure, when the pump is idle.

Filter

11. A cylindrical wire gauze filter completely encloses the portway casting, and prevents the ingress of foreign matter to the interior of the pump, from the fuel tank.

OPERATION

12. The impeller, driven at constant speed, accepts fuel from the tank, and generates the required pressure in the volute, to the pump delivery outlet, and thence to the fuel line.

13. Under conditions when the pump is supplying fuel in excess of engine requirements, the impeller continues to rotate, but the pressure is maintained within pre-determined limits.

14. When the pump is idle, the pressure on the underside of the by-pass valve is relieved, and therefore opens, to allow fuel to pass from the tank through the sump, when the engine driven pump is drawing fuel from the tank.

15. The type of impeller used in the pump ensures maximum performance of the pump under conditions of sudden and rapid deceleration, due to high rates of climb, and other manoeuvres. It also assists in quick recovery from vapour locking, caused by the temporary removal of fuel from the vicinity of the impeller.

INSTALLATION

16. When fitting a new pump, ensure that the fuel tank has been emptied, before removing the old pump, by easing off the joint of the fuel delivery outlet pipe. If there is any fuel left in the tank, it will have a free passage through the by-pass valve, which will be open when the pump is idle.

17. When it is certain that the fuel tank is empty, disconnect the fuel delivery outlet pipe, and the electrical supply cable from the Breeze type plug. Next remove the nuts securing the pump to its seating on the fuel tank, and carefully withdraw the pump from the tank. Suitable bolts screwed into the two $\frac{1}{4}$ in. B.S.F. tapped extractor holes in the pump base, will assist in this operation.

18. Before fitting the new pump make sure that it is clean externally, and that any adhesive tape, or plugs, which serve as protection over the pump apertures have been removed. In addition, ensure that the jointing ring on the mounting flange of the pump is in good condition. Insert the pump through the aperture in the fuel tank, and tighten up the securing nuts around the pump mounting flange.

19. To ensure that the pump is free from foreign matter, prior to finally connecting the fuel supply pipes, the electrical supply cable should be connected to the pump and the motor switched on. A small quantity of fuel put into the tank will then be delivered by the pump into a suitable receptacle, and in passing through the pump the fuel will carry any impurities with it. When this has been done the pump outlet may be connected with the fuel supply line.

20. When received from Stores the gland drain exit will be fitted with a plug. When the new pump has been installed, and tested, this plug should be removed, and a drain pipe fitted. This pipe should be installed in such a manner, that the level of the pipe at no point is higher than the connection,

when the aircraft is on the ground, or, in level flight. The outlet end of this pipe must be external to the aircraft, and should terminate in a low pressure area. The end of the pipe should be cut at 45 degrees with the chamfer facing aft. Failure to fit this pipe may result in fuel, which may have seeped through the flexibox fuel sealing gland, washing away the grease from the motor lower bearing, and causing possible failure of the bearing.

Note . . .

In all instances where any doubt exists with regard to the method of installing, or removing a pump from the aircraft, reference should be made to the appropriate Aircraft Handbook.

SERVICING

Electrical test

21. A routine electrical test must be made to ascertain that the motor of the fuel pump is operating correctly. ENSURE THAT THE PUMP IS IMMERSSED IN FUEL WHEN THESE TESTS ARE IN PROGRESS.

22. Having ascertained the position of the aircraft fuel pump test socket and switches, by reference to the appropriate Aircraft Handbook, proceed as follows :—

- (1) Close all fuel cocks between pumps and engines to ensure that no fuel can flow.
- (2) Connect a suitable portable ammeter to the socket on the test panel.
- (3) Switch on the pump by pressing the switch on the test panel, NOT THE NORMAL FUEL PUMP SWITCH, for a period of not less than half a minute. During this period the current consumption of the motor should

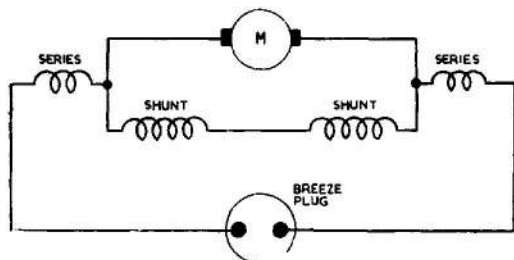

Fig. 3. Circuit diagram

be noted, and the readings as registered by the ammeter, should be interpreted as follows :—

- (a) A steady reading of not more than 8 amp. indicates that the motor is satisfactory.
- (b) A reading in excess of the figure in (a) indicates that the pump motor is faulty.
- (c) A fluctuating reading indicates faulty contacts, defective brushes, or faulty commutator.
- (d) A zero reading is consistent with, either a blown fuse, defective wiring or switch, or complete motor failure.

23. When these tests have been satisfactorily completed, release the test switch, and disconnect the ammeter from the test socket.

Operational test

24. When the electrical tests have been completed, the pump should be tested to observe the pressure of fuel being delivered. The pressure should be 9 lb. per sq. in. minimum. If this pressure is not obtained, the fault may probably be traced to a damaged impeller, or, a defective flexibox fuel sealing gland.

Routine inspection

25. When examining the pump at the appropriate inspection periods, care should be taken to conform with the following points :—

- (1) Examine the fuel outlet pipe coupling, and Breeze type plug connection for fuel tightness.
- (2) Test the pump as detailed in para. 21 to 24. If the pump is found to be faulty it must be returned to Stores, and a replacement fitted.
- (3) Ensure that the by-pass valve is functioning correctly. To do this turn on the tank selector cock, and the appropriate engine master cock ; then switch on the pump and observe the fuel pressure, as indicated by the fuel pressure gauge, or fuel pressure warning light. Very low pressure, or failure to extinguish the warning light, indicates that the by-pass valve is not

functioning correctly. In certain installations the fuel pressure warning light is set to operate at a pressure higher than that which the pump can deliver. Therefore observe the light setting before rejecting a suspected pump. The pump is unlikely to be

defective if it delivers fuel at a pressure in excess of 9 lb. per sq. in.

26. At the period laid down in the appropriate Servicing Schedules, all pumps are to be replaced by new or reconditioned pumps drawn from Stores. Old or faulty pumps are to be returned for reconditioning.

RESTRICTED

This file was downloaded
from the RTFM Library.
Link: www.scottbouch.com/rtfm

Please see site for usage terms,
and more aircraft documents.

