

Chapter 12

PUMPS, FUEL, PAC. 500 SERIES

LIST OF CONTENTS

| | Para. | | Para. |
|--------------------------|-------|--|-------|
| <i>Introduction</i> | 1 | Removal and Installation | 12 |
| Description | | Servicing | |
| <i>General</i> | 5 | <i>Routine inspection</i> | 15 |
| <i>Motor unit</i> | 6 | <i>Operational test</i> | 17 |
| <i>Pump unit</i> | 7 | <i>Gland leakage</i> | 18 |
| <i>Mounting</i> | 9 | <i>Insulation resistance test</i> | 19 |
| Operation | 10 | | |

LIST OF ILLUSTRATIONS

| | Fig. |
|---|------|
| <i>General view of Type PAC. 500 fuel pump</i> | 1 |
| <i>Sectional view of Type PAC. 500 fuel pump</i> | 2 |
| <i>Circuit diagram</i> | 3 |

LIST OF APPENDICES

| | App. |
|--|------|
| <i>Pumps, fuel, Type PAC. 500 Mk. 1, 2 and 3</i> | 1 |

RESTRICTED

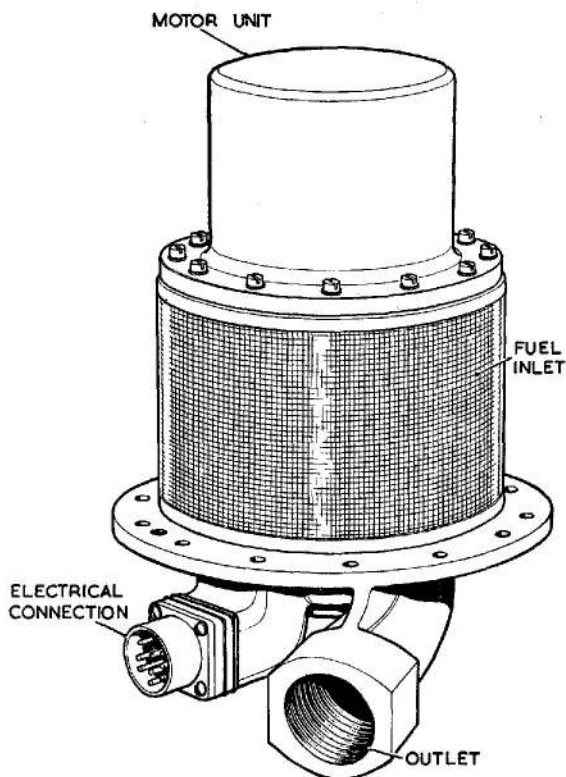

Fig. 1. General view of Type PAC. 500 fuel pump

Introduction

1. Type PAC. 500 fuel booster or transfer pumps are designed to supply fuel under pressure to the aircraft fuel supply line at all conditions of fuel de-aeration, high altitude vapour formation and extremes of temperature.

2. The pump is of the base mounting type with the fuel delivery outlet, gland drain and electrical connections arranged below the mounting flange. Motor unit cooling is effected by the fuel in the tank.

3. In service the pump is bolted through the base flange and associated gasket to a reinforced stud ring in the aircraft tank.

4. Differences between the various marks of Type PAC. 500 fuel pumps are detailed in the appendix to this chapter.

DESCRIPTION

General

5. General and sectional arrangements of the complete pump are illustrated in Fig. 1. and 2. The unit comprises mainly an a.c.

motor unit with extended rotor shaft driving a high altitude centrifugal type impeller. A vapour deflector fitted around the impeller inlet directs the fuel and air vapour evolved away from the impeller, the fuel inlet to which is protected by a wire mesh filter.

Motor unit

6. The pump is driven by a motor operating from a 200V, 3-phase, 400 c/s supply. The extended rotor shaft, supported at each end by ball bearings, carries the impeller together with a mechanical seal preventing fuel ingress into the motor unit. Rotation is anti-clockwise when viewed from the drive-end, with phases connected in sequence red (A) white (B) and blue (C), from left to right. Electrical connection to the motor is by way of a 9-pin Breeze plug. A circuit diagram is shown in fig. 3.

Pump unit

7. A mechanical seal, the rotating carbon member of which is fitted to the upper surface of the impeller stem, prevents fuel access into the motor unit. Any slight leakage past the seal is drained through pump casing channels to the undersurface of the pump base from where a piped connection carries it to atmosphere.

8. The fuel inlet to the impeller is protected by a wire mesh filter, and a vapour guide cone ensures that fuel and air vapour evolved is directed away from the impeller and has access back to the tank through ports in the pump casing.

Mounting

9. The pump base casting carries the 9-pin electrical connection, $1\frac{1}{4}$ in. B.S.P. delivery outlet and a $\frac{1}{4}$ in. B.S.F. gland drain tapping, and provides a flange for securing the pump assembly to a reinforced stud ring in the base of the aircraft tank.

OPERATION

10. Fuel from the tank enters the pump through the wire mesh filter into the eye of a centrifugal impeller driven by the extended rotor shaft. From here it is forced through a spiral volute into the delivery line and thence to the inlet side of the engine driven pump or into main or auxiliary fuel tanks, dependent on whether unit is being used as a booster or transfer pump.

11. Under conditions in which the flow from a unit used as a booster pump is low, due to low engine requirements, the impeller

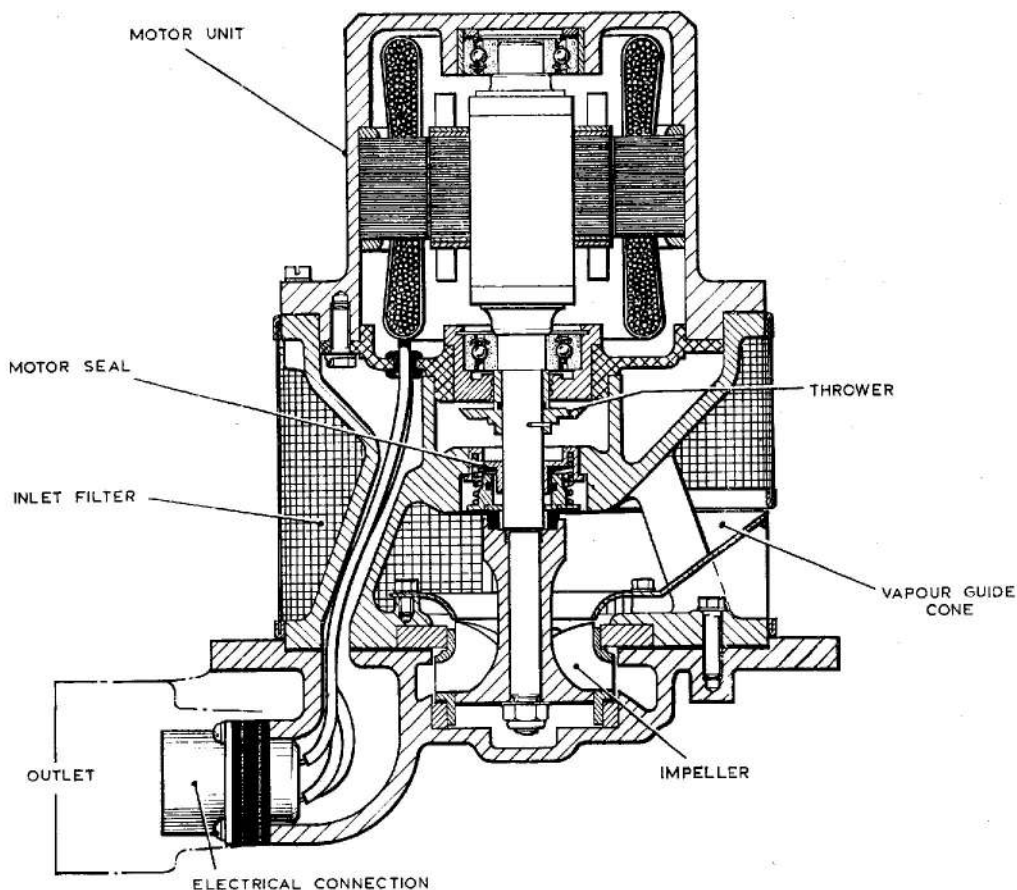

Fig. 2. Sectional view of Type PAC. 500 fuel pump

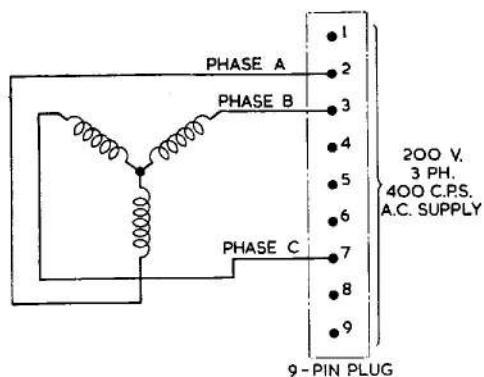

Fig. 3. Circuit diagram

continues to rotate at approximately normal speed without causing any excessive increase in fuel pressure.

REMOVAL AND INSTALLATION

12. Before attempting to remove a pump ensure that the tank has been drained of fuel and that electrical supply to the pump motor unit has been disconnected. The precise method of removing the pump will be found in the appropriate Aircraft Handbook. In general terms it will comprise disconnection of the fuel delivery, electrical and gland drain connections, and removal of the pump from the tank bolt ring. Care should be taken to support the weight of the pump during the latter operation.

13. Installation of a new pump should be preceded by the following checks:—

- (1) Ensure that the pump has not been stored longer than the specified maximum period (i.e. 12 months in original packing and carton as supplied by

RESTRICTED

manufacturer or 3 years where special packing has been provided).

(2) Inspect the exterior of the pump for evidence of damage and security of locking wires. Parts most susceptible to damage are the electrical connection and inlet filter. Check for any signs of corrosion. Blend out slight areas of corrosion and apply a protective finish (e.g. chromic acid solution) to the unprotected area.

(3) Ensure that the pump is scrupulously clean externally.

(4) Remove any transit plugs, caps or other protective material from the delivery outlet, the electrical connection and the gland drain.

(5) It is advisable to make a starting check on the pump before installation. To do this the carbon shaft bearing should be first lubricated by inverting the pump and partially immersing it in fuel. Take care that no fuel enters the gland drain or contaminates the electrical connection. Apply a 200V, 3-phase, 400 c/s supply through the Breeze plug connection using an approved mating socket. The pump should start immediately. Switch off the supply current and repeat the test several times. If the pump fails to start immediately it should be returned to base for further serviceability testing using approved equipment.

Note . . .

The above pre-installation instructions apply to all aircraft installations of these pumps. For detailed procedure covering installation in a particular aircraft reference should be made to the appropriate Aircraft Handbook.

14. As a general example installation in the aircraft will comprise the following operations:—

(1) Smear the mating surfaces of the pump and tank stud with approved jointing compound, fit new gasket and secure pump in position.

(2) Connect the fuel delivery line, electrical supply and gland drain connections. Note that the pipe connection from the gland drain must face towards the rear of aircraft to prevent possible pressurisation in flight.

(3) Wire lock all external connections to the pump assembly.

SERVICING

Routine inspection

15. At routine inspections care should be taken to conform to the following procedure:—

(1) Inspect all pipe connections and wire locking to the pump. Correct as necessary. If the pump is found to be defective in any way a substitute must be fitted. No in-situ servicing is possible.

16. At the periods laid down in the appropriate servicing schedules, all pumps are to be replaced by new or reconditioned pumps drawn from stores. Faulty or life expired pumps must be returned to a maintenance unit or to the manufacturer for repair.

Operational test

17. Subject to the electrical tests being satisfactory, the pump should be tested for proof of performance, and checked against the figures given under Leading Particulars. Failure to obtain the quoted pressures and rate of fuel delivery could be caused by a faulty motor unit, damaged impeller or an incorrect loading of the pump unit gland. The pump should be removed to ascertain cause of failure.

Gland leakage

18. During these tests examination should be made of the gland drain exit for fuel leakage. Leakage must not exceed two drops per minute while the pump is running or one drop per minute while stationary. Any leakage in excess of these figures will necessitate removal of the pump.

Insulation resistance test

19. Using a 500V insulation resistance tester measure the insulation resistance of the pump between live parts and the frame. The insulation resistance tester used for this check should be fitted with an electrical socket to suit the pump Breeze plug. When a new pump is installed the insulation resistance should not be less than 2 megohms. After installation for operational service, due to the humidity prevalent in aircraft at dispersal points, the minimum insulation resistance permissible is 50,000 ohms.

R E S T R I C T E D

Appendix 1

PUMPS, FUEL, PAC. 500 Mk. 1, 2 and 3

LEADING PARTICULARS

| | | | |
|---|------|--|---|
| Pump, fuel, Type PAC. 500 Mk. 1 | | | Ref. No. 5UE/6353 |
| Pump, fuel, Type PAC. 500 Mk. 2 | | | Ref. No. 5UE/ |
| Pump, fuel, Type PAC. 500 Mk. 3 | | | Ref. No. 5UE/6851 |
| Operating voltage | | | 200V, 3-phase a.c. |
| Frequency | | | 400 c/s |
| Motor unit | | Fuel cooled English Electric Type AE.1160 | |
| Rated output | | | 500 g.p.h. |
| Fuel delivery pressure at operating voltage | | | 12.0-14.0 lb/in ² |
| Maximum power output | | | 340W |
| No-flow delivery pressure (max) | | | 17 lb/in ² |
| Breeze plug, Plessey Type CZ. 50357 | | | Ref. No. 5X/6182 |
| Phase connections | | | Red (A)—to pin 2 White (B)—to pin 3 Blue (C)—to pin 7 |
| Maximum shaft eccentricity when running in its own bearing | | 0.001 in. total indicator reading | |
| Motor spigot concentricity to shaft | | 0.002 in. total indicator reading | |
| Motor unit bearings | | Single shielded. Packed with XG/295 grease | |
| Delivery outlet | | | 1¼ in. B.S.P. |
| Gland drain | | | ¼ in. B.S.P. |
| Weight of unit (all marks) | | | 10.0 lb. |

Note . . .

Dismantling the above pump to inspect or renew bearings, gland faces, etc., will necessitate full re-testing of the unit in accordance with the approved Schedule of Acceptance Tests.

TYPE DIFFERENTIATION

Basic differences between the various marks of PAC. 500 pumps are as follows:—

| | | | |
|----------------|------|------|--|
| PAC. 500 Mk. 1 | | | Basic design |
| PAC. 500 Mk. 2 | | | Generally as Mk. 1 but impeller re-designed and bottom slipring removed |
| PAC. 500 Mk. 3 | | | Generally as Mk. 2 but steel vapour baffle fitted in place of light alloy components |

RESTRICTED



This file was downloaded
from the RTFM Library.

Link: www.scottbouch.com/rtfm

Please see site for usage terms,
and more aircraft documents.

