

Chapter 14

PUMPS, FUEL, SPE.1230 SERIES

LIST OF CONTENTS

	Para.		Para.
<i>Introduction</i>	1	<i>Base sump mounting fuel booster pumps</i>	18
<i>Pump mountings</i>	3	<i>Twin base sump mounting fuel booster pumps</i>	21
Description		Operation	24
<i>Typical pump and motor unit assembly</i>	4	Removal and installation	27
<i>Motor unit</i>	5	Servicing	
<i>Pump unit</i>	7	<i>Routine inspection</i>	30
<i>Type descriptions:</i>		<i>Electrical test</i>	32
<i>Side mounting fuel booster pumps</i>	11	<i>'No fuel flow' electrical test</i>	33
<i>Base flush mounting fuel booster pumps</i>	15	<i>Operational test</i>	36
		<i>Gland leakage</i>	37
		<i>Insulation resistance test</i>	38

LIST OF ILLUSTRATIONS

	Fig.		Fig.
<i>Typical fuel tank pump mountings</i>	1	<i>Typical base sump mounting fuel booster pump</i>	5
<i>Typical SPE.1230 series pump and motor unit assembly</i>	2	<i>Typical twin base sump mounting fuel booster pump assembly</i>	6
<i>Typical side mounting fuel booster pump</i>	3	<i>Circuit diagram</i>	7
<i>Typical base flush mounting pump</i>	4	<i>'No fuel flow' electrical test graph</i>	8

LIST OF APPENDICES

	App.		App.
<i>Pump, fuel, SPE.1234</i>	1	<i>Pump, fuel, SPE.1236</i>	3
<i>Pump, fuel, SPE.1235</i>	2	<i>Pump, fuel, SPE.1237</i>	4

Introduction ...

1. The SPE.1230 series of electrically driven fuel booster pumps are designed to maintain the required fuel supply to the aircraft engine driven pump under the varying fuel temperature and altitude conditions experienced in flight. The pumps are suitable for use on a 200 volt, 400 cycle, 3-phase a.c. aircraft supply and have a nominal delivery rating of 1,200 gallons per hour.

2. All the pumps in this series are of the right-angled drive type to suit installation requirements where fuel tank depth is restricted by thin wing sections or other considerations. The method of mounting the pump (side, base flush or base sump) constitutes one of the main differences between basic types of pump in the series (para. 3).

RESTRICTED

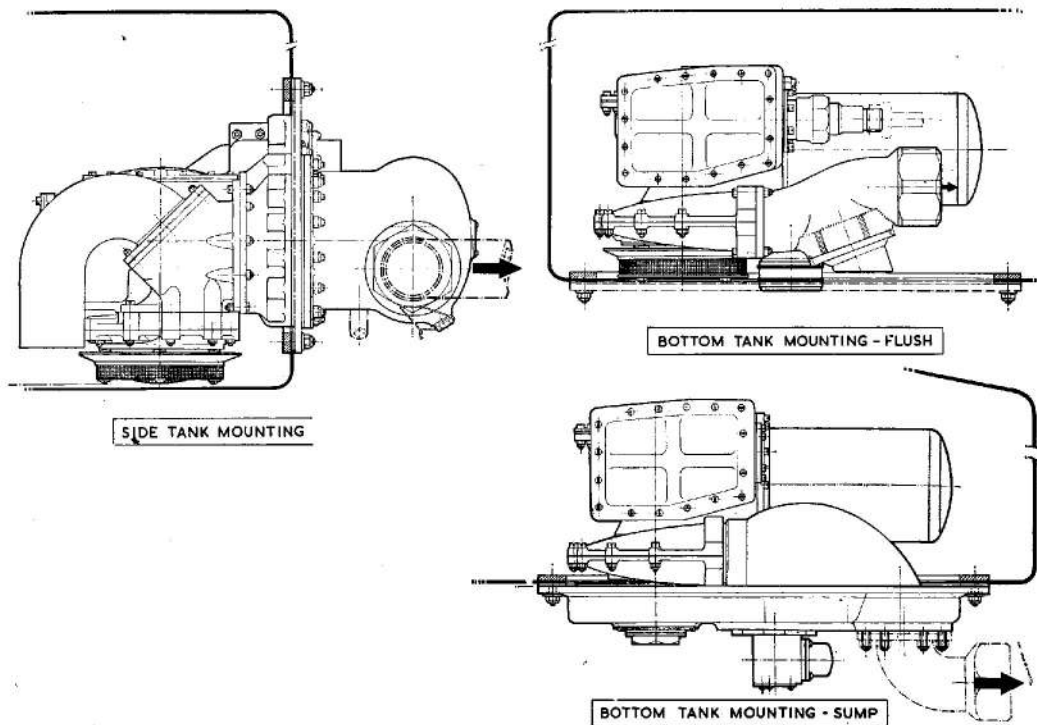

Fig. 1. Typical fuel tank pump mountings

Pump mountings

3. The different types of mounting are illustrated in fig. 1, and may be defined as follows:—

(1) **Side mounting.** Provision is made for including in the assembly a mounting plate for securing the pump to the side of the tank so that the pump unit is within the tank with the motor unit protruding. The electrical connection to the pump motor is made externally.

(2) **Base flush mounting.** With this type of mounting the pump is wholly within the fuel tank and bolted to a cast mounting plate secured to a stud ring in the base of the tank. The electrical connection to the pump motor is through a special fuel tight electrical connection on the pump casting.

(3) **Base sump mounting.** The use of a sump or dished mounting plate for the pump enables the fuel tank to which it is fitted to be completely drained, either by the action of the pump or by a removal of a drain plug located in the mounting plate. The electrical connection to the pump is made externally.

DESCRIPTION

Typical pump and motor unit assembly

4. A typical pump and motor unit assembly is illustrated in fig. 2. This basic arrangement is common to all SPE.1230 series pumps except for minor casting profile details to suit the various installation requirements.

Motor unit

5. The motor units fitted to these pumps are totally enclosed, consequent wound, four-pole laminated machines, operating on a 200-volt, 400 cycle, 3-phase supply. The rotor is of squirrel cage construction supported by two shielded bearings, and is fitted with a bevel pinion engaging with a bevel gear on the pump shaft, providing a reduction of approximately 2:1.

6. The type and position of the electrical connections to the motor unit varies with the mounting arrangement.

Pump unit

7. The two stage centrifugal pump unit, driven through the right-angled bevel gearing, comprises a first stage helical impeller and a second stage centrifugal impeller

RESTRICTED

mounted on a common vertical shaft. This shaft is supported at its upper end by a shielded ball-bearing and at its lower end in a plain carbon bearing lubricated by fuel. Fuel from the impeller system is fed into the delivery line, by way of a spiral volute.

8. The main casting or pump body housing the impeller system also contains the metallic bellows type seal unit which prevents fuel ingress into the motor unit and gear chamber. Any slight fuel leakage past this gland will be dissipated by a thrower ring incorporating a labyrinth type seal, and drained to atmosphere through drain channels in the pump castings.

9. Foreign matter is prevented from entering the pump unit by a wire mesh filter which encloses the inlet. A vapour guide cone surrounding the inlet to the impeller system assists in separating fuel and air bubbles dissipated from the tips of the impeller helix.

10. The delivery outlets from the volute chamber differ in each mounting arrangement. All the pumps in the series are however fitted with a simple hinged-plate by-pass valve at some point in or adjacent to the delivery outlet which enables the engine driven pump to draw fuel from the tank in the event of booster pump failure.

The valve is normally held closed by booster pump pressure.

Type descriptions

11. *Side mounting fuel booster pumps.* In a typical side mounting SPE. 1230 series fuel booster pump, the pump and motor unit are basically as described in para. 4-10, but the pump shaft is slightly longer to suit installation requirements.

12. The fuel delivery line is connected outside the tank to either of two horizontally opposed $1\frac{1}{2}$ in. B.S.P. outlet connections on the fuel jacket surrounding the motor unit. This fuel jacket also includes a $\frac{1}{4}$ in. B.S.P. gland drain tapping, the channel to which is incorporated in the casting and mates with a similar duct in the main pump body. A by-pass valve is mounted over the delivery duct and is backed by a fabricated duct formed so that the end is immersed in fuel until the tank is almost empty.

13. The electrical connection is made to a special plug fitted to an external mounting surface of the pump casting.

14. The side mounting fuel pumps are normally supplied with a mounting plate and associated gaskets. The fuel jacket is attached in a few positions only with additional nuts supplied in a separate package.

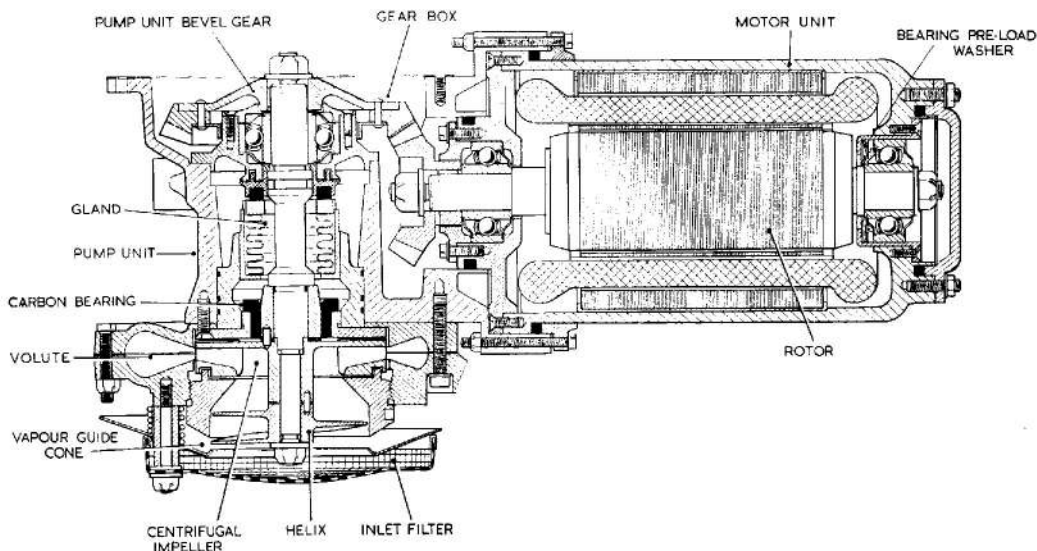

Fig. 2. Typical SPE. 1230 series pump and motor unit assembly

RESTRICTED

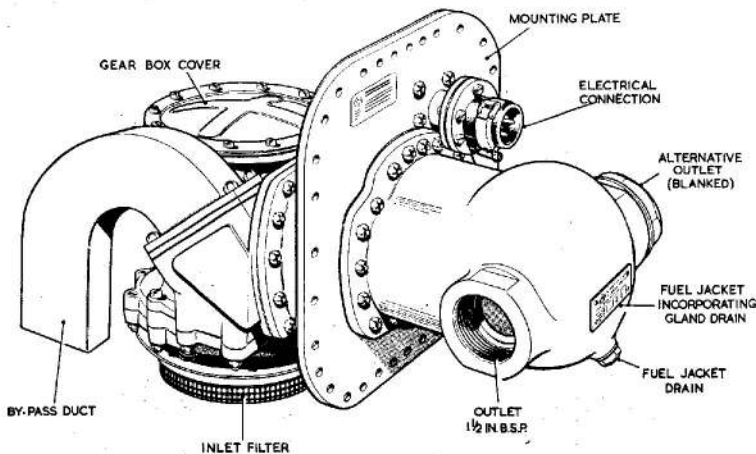

Fig. 3. Typical side mounting fuel booster pump

15. *Base flush mounting fuel booster pump.* The SPL. 1230 series base flush mounting fuel booster pumps are fitted with a pump and motor unit basically as described in para. 4-10.

16. The fuel delivery line is connected within the tank to a 1½ B.S.P. outer casting which includes the by-pass valve enabling fuel to be drawn from the tank with the booster pump idle. A mounting flange and boss is provided for bolting the pump to the tank mounting plate (not normally supplied with the pump). Both the gland drain and motor breather channels are brought to the outside of the tank through this mounting boss.

17. The electrical connection to the pump is made within the fuel tank and is of a special flameproof and fuel tight design.

18. *Base sump mounting fuel booster pump.* In a typical base sump mounting SPE. 1230 series fuel booster pump, both the pump and motor unit are basically as described in para. 4-10.

19. The pump is bolted to a dished sump type mounting plate through an extension of the lower volute casting. The fuel delivery line connection is made outside the tank to a stud ring in the base of the sump. The by-pass valve which enables fuel to be drawn from the tank when the pump is idle, is

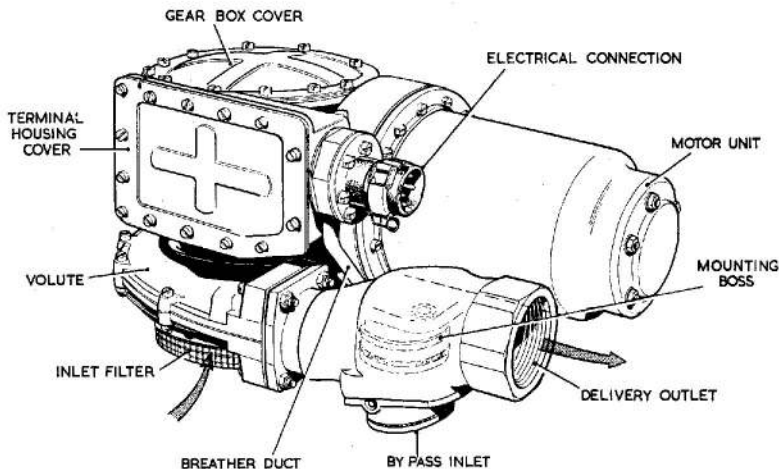

Fig. 4. Typical base flush mounting pump

RESTRICTED

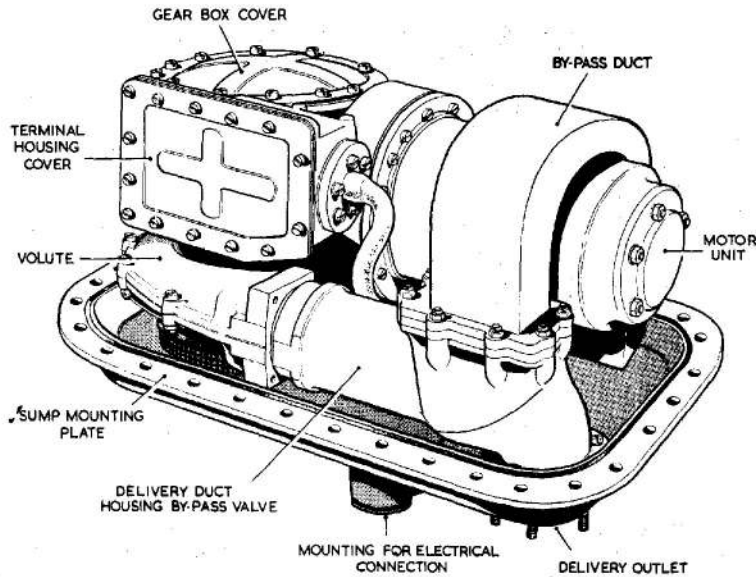

Fig. 5. Typical base sump mounting fuel booster pump

included in the connector casting assembly linking the pump volute to the sump outlet.

20. The electrical connection to the pump is made externally through a special plug fitted to a carrier assembly secured to the undersurface of the sump mounting plate.

This carrier casting also incorporates the motor breather.

21. *Twin base sump mounting fuel booster pump.* This type of unit comprises two fuel booster pumps mounted to one large base sump casting. The pump and motor units are basically as described in para. 4-10.

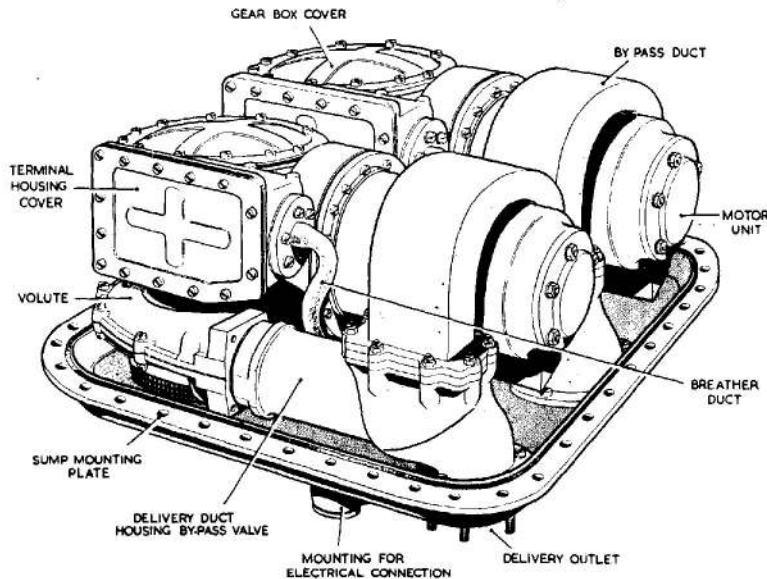

Fig. 6. Typical twin base sump mounting fuel booster pump assembly

RESTRICTED

22. The pumps are bolted to a dished sump type mounting plate through extensions of the lower volute castings. The fuel delivery line connections are made outside the tank to stud rings in the base of the sump. The by-pass valves which enable fuel to be drawn from the tank when the pumps are idle, are included in the connector casting assemblies linking the pumps to the sump outlets.

23. The electrical connections to these pumps are made externally through special plugs fitted to the carrier assemblies secured to the undersurface of the sump mounting plate. These carrier castings also incorporate the motor breathers.

OPERATION

24. Fuel from the tank enters the pump through a wire mesh filter and is picked up by a helical impeller which serves the dual purpose of de-aerating and pressurising the fuel at the eye of the centrifugal impeller. This latter impeller feeds the fuel through the spiral volute chamber and finally into the outlet duct.

25. Under conditions in which the flow from the booster pump is low, due to reduced engine requirements, the impeller continues to rotate at approximately normal speed without causing any excessive increase in fuel pressure.

26. When the pump is idle the pressure on the by-pass valve is relieved. As a result the valve opens and allows the engine driven pump to draw fuel direct from the tank without passage through the pump impeller system.

REMOVAL AND INSTALLATION

27. Before attempting to remove a pump ensure that the tank has been drained of fuel and that the electrical supply to the pump motor unit has been switched off. The former can be checked by easing the tank drain plug which may be fitted either in the tank itself or on the pump mounting plate. The precise method of removing each type of pump will be detailed in the appropriate Aircraft Handbook. Generally it will comprise the disconnection of the fuel delivery and the electrical and gland drain connections, and the removal of the pump mounting plate from the tank bolt ring. Care should be taken to support the weight of the pump during the latter operation.

28. The installation of a new pump should be preceded by the following checks:

(1) Ensure that the pump has not been stored for longer than the specified maximum period (i.e. 12 months in the original packing and carton as supplied by the manufacturer or 3 years where special packing has been provided.)

(2) Inspect the exterior of the pump for evidence of damage and security of the pump locking wires. Check for any signs of corrosion. Blend out slight areas of corrosion and apply a protective finish (e.g. chromic acid solution) to the unprotected area.

(3) Ensure that the pump is scrupulously clean externally.

(4) Remove the transit plugs, caps and other protective material from the delivery outlet, the electrical connection, the gland drain and the motor breather.

(5) It is advisable to make a starting check on the pump before installation. To do this the carbon shaft bearing should be lubricated by pouring a small quantity of fuel through the small holes in the pump casting at seal level, care being taken to ensure that fuel does not contaminate the electrical connection or flow into the gland drain or motor breather ducts. Apply a 200 volts, 400 cycles, 3-phase a.c. supply to the pump. The pump should start immediately. Switch off the supply and repeat the test several times. If the pump fails to start immediately it should be returned to a Repair Depot for further serviceability testing using approved equipment.

The above pre-installation instructions apply to all aircraft installations of these pumps. For detailed procedure covering installation in a particular aircraft reference should be made to the appropriate Aircraft Handbook.

29. As a general example installation in the aircraft will comprise the following operations:

(1) Ensure that new seal rings and gaskets are fitted where necessary to all pump/mounting plate or mounting plate/tank bolt joints. Note that the seal ring in the periphery groove of the base and sump mounting plates is fixed in position with rubber cement.

(2) Connect the fuel delivery line, the electrical supply and gland drain connections either before or after offering the pump assembly to the tank bolt ring;

RESTRICTED

this being dependent on whether these connections are inside or outside the fuel tank. The pipe from the gland drain should always face to the rear of the aircraft; this will prevent possible pressurisation in flight.

(3) Secure the pump mounting plate to the fuel tank bolt ring with the requisite number of nuts and lock-washers. Tighten the nuts in turn to ensure even compression of the joint washers and seal rings.

(4) Wire lock all the internal and external connections to the pump assembly.

SERVICING

Routine inspection

30. At routine inspections care should be taken to conform to the following procedure:

(1) Inspect all the pipe connections and wire locking to the pump. Correct as necessary.

(2) Test the pump as detailed in para. 32-38. If the pump is found to be defective it must be removed, and a new or reconditioned one fitted. No in-situ maintenance is possible.

(3) Ensure that the by-pass valve is functioning correctly. To do this turn on the tank selector cock and the appropriate engine master cock. Switch on the pump and observe the fuel pressure indicated by the aircraft fuel pressure gauge or warning light. Very low pressure on the gauge or failure to extinguish the warning light indicates that the by-pass valve is not functioning efficiently. In certain installations the fuel pressure warning light may be set to operate at a higher pressure than that at which the pump is rated. The warning light setting for the particular installation should therefore be checked before rejecting a suspected pump.

31. At the periods laid down in the appropriate servicing schedules, all pumps are to be replaced by new or reconditioned pumps drawn from stores. Faulty pumps must be returned to a Maintenance Unit, or to the manufacturer for repair.

Electrical test

32. A periodic electrical check in accordance with the appropriate Servicing Schedule

should be made to ascertain that the motor is functioning satisfactorily. The pump must be replaced by a new or reconditioned one, if there is any indication of erratic performance such as excessive current consumption, or unusual running features. These tests should only be made with the motor on load, i.e., immersed in and pumping fuel.

Note . . .

The following "No fuel flow" electrical test is only applicable to aircraft, provided with a test panel. Where no provision is made for this test, particular attention should be made to the Electrical test and the Operational test described in para. 32 and 36.

'No fuel flow' electrical test

33. Before applying the electrical test at 'no fuel flow' ascertain the position of the aircraft pump test panel and switches, by reference to relevant Aircraft Handbook. When this has been done proceed as follows:—

(1) Close all the fuel cocks between the pumps and engines to ensure that no fuel can flow.

(2) Connect a clip on type, portable ammeter to the test coil on the test panel.

(3) Switch on the pump by depressing the test push-switch on the test panel and note the reading of the ammeter for a period of not less than half-a-minute.

Note . . .

Before using the tong tester, open and close the tongs smartly; this reduces errors due to hysteresis which otherwise may be considerable if the value of the current in the coil is increasing or decreasing.

34. Interpret readings obtained as follows:

(1) A steady reading not exceeding that indicated by the graph (Fig. 8) for the measured applied voltage, indicates that the motor is functioning satisfactorily.

Note . . .

The graph (Fig. 8) is provided as a guide to pump performance under 'no flow' conditions: the figures derived from it are not to be inter-

RESTRICTED

puted as forming a part of the approved Acceptance Test Specification for the pump.

(2) Current consumption in excess of the graph reading indicates either a faulty motor unit, a rise in torque loading due to the obstruction of moving parts, or a restriction of the fuel flow.

(3) A fluctuating reading indicates faulty contacts, defective brushes, faulty commutation or that bearings or other rotating parts are binding.

(4) A zero reading indicates an open circuit and is consistent with a blown fuse, defective switch, faulty wiring or in extreme cases, a complete motor failure.

35. When the above checks have been completed, release the test push switch on the test panel and release the ammeter from the test coil.

Operational test

36. Subject to the electrical tests being satisfactory, the pump should be tested for proof of performance, and checked against the figures given in the appropriate appendix to this chapter.

Failure to obtain the quoted pressures and rate of fuel delivery could be caused by a faulty motor unit, damaged impeller, or an incorrect loading of the pump unit bellows

type gland unit. The pump should be removed to ascertain the cause of failure.

Gland leakage

37. During the tests an examination should be made of the gland drain exit for fuel leakage. The leakage must not exceed 2 drops per minute while the pump is running or 1 drop per minute while stationary. Any leakage in excess of these figures will necessitate removal of the pump.

Insulation resistance test

38. Using a 500-volt insulation resistance tester, measure the insulation resistance between live parts and earth. When a new pump is installed the insulation resistance should not be less than 2 megohms. After installation for operational service, due to the humidity prevalent in aircraft at dispersal points, the minimum insulation resistance permissible is 50,000 ohms.

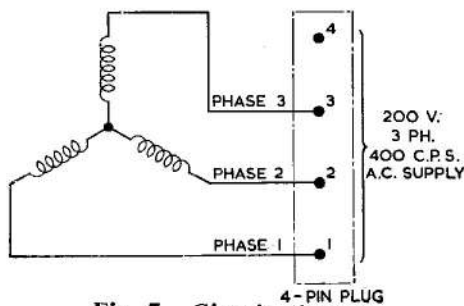

Fig. 7. Circuit diagram

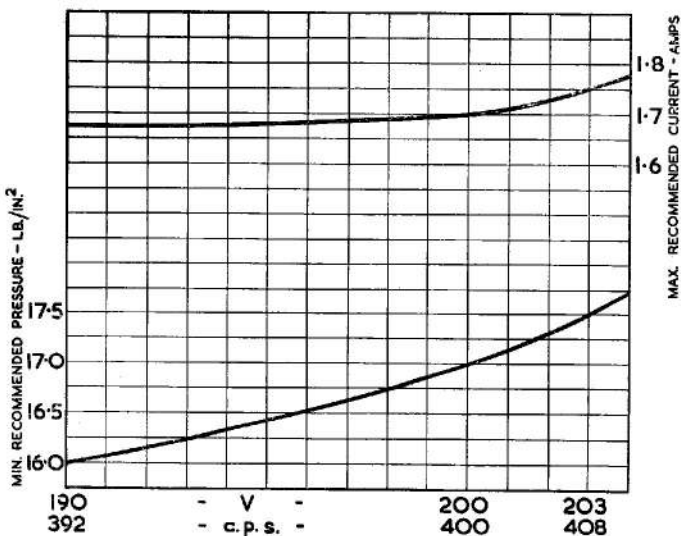

Fig. 8. "No fuel flow" electrical test graph

RESTRICTED

Appendix 1

PUMPS, FUEL, SPE.1234

LIST OF ILLUSTRATIONS

	Fig.
Sectional view of SPE.1234, Mk. 2 fuel pump	1
Sectional view of SPE.1234, Mk. 2 bypass valve	2

LEADING PARTICULARS

Pump, fuel, Type SPE.1234 Mk. 1	Ref. No. 5UE/6712
Pump, fuel, Type SPE.1234 Mk. 1A	Ref. No. 5UE/6712
Pump, fuel, Type SPE.1234 Mk. 1B	Ref. No. 5UE/7511
Pump, fuel, Type SPE.1234 Mk. 1D	Ref. No. 5UE/
Pump, fuel, Type SPE.1234 Mk. 2	Ref. No. 5UE/6712
Pump, fuel, Type SPE.1234 Mk. 3	Ref. No. 5UE/7492
Pump, fuel, Type SPE.1234 Mk. 5	Ref. No. 5UE/
Operating voltage	200V, 3-phase, a.c.
Frequency 400 c/s
Motor unit	Fuel cooled: consequent wound 4-pole laminated construction.
Rated output at operating voltage	1200 gal./hr.
Minimum fuel delivery pressure at rated output/operating voltage	
Mk. 1 only	11.75 lb./in. ²
All Mk. except Mk. 1	12.75 lb./in. ²
Max. current consumption at rated output/ operating voltage	
Mk. 1 only 1.6A
All Mk. except Mk. 1 1.7A
Maximum 'no flow' delivery pressure at 200V., 400 c/s	22.0 lb./in. ²
Minimum 'no flow' delivery pressure	See Fig. 8, basic chapter.
Electrical connection	SPE.13995 (special)
Phase connections	Red (1)—to pin 1. Yellow (2)—to pin 2. Blue (3)—to pin 3.
Delivery outlet	1½ in. B.S.P.
Gland drain	¼ in. B.S.P.
Weight of unit	
Mk. 1 only 16.5 lb.
All Mk. except Mk. 1	16.25 lb. approx.

RESTRICTED

Introduction

1. The type SPE.1234 fuel pump is of the side mounting, right-angled drive type as described in para. 11-14 of the basic chapter. Illustrations showing the main features of this type of pump will be found at the end of this appendix.

Type differentiation

2. Basic differences between the various marks of SPE.1234 pumps are as follows:—

SPE.1234 Mk. 1

Basic design.

SPE.1234 Mk. 1A

Generally as Mk. 1 but the motor unit windings redesigned.

SPE.1234 Mk. 1B

Generally as Mk. 1A but gear box and terminal board chamber covers redesigned to include bonded rubber gaskets. Type of gear chamber lubricant changed.

SPE.1234 Mk. 1D

Generally as Mk. 1B but fitted with redesigned gear and pinion. Further change of specified gear chamber lubricant.

SPE.1234 Mk. 2

Internal design similar to the Mk. 1A pump but the main pump body castings redesigned to reduce the total weight of the pump. It is not economically possible to convert a Mk. 1A pump to Mk. 2 standard.

SPE.1234 Mk. 3

Generally similar to Mk. 2 but gear box and terminal board chamber covers redesigned to include bonded rubber gaskets. Type of gear chamber lubricant changed.

SPE.1234 Mk. 5

Generally as Mk. 3 pump, but fitted with redesigned gear and pinion. Further change of specified gear chamber lubricant.

Note . . .

SPE.1234 Mk. 1C and Mk. 4 were not produced.

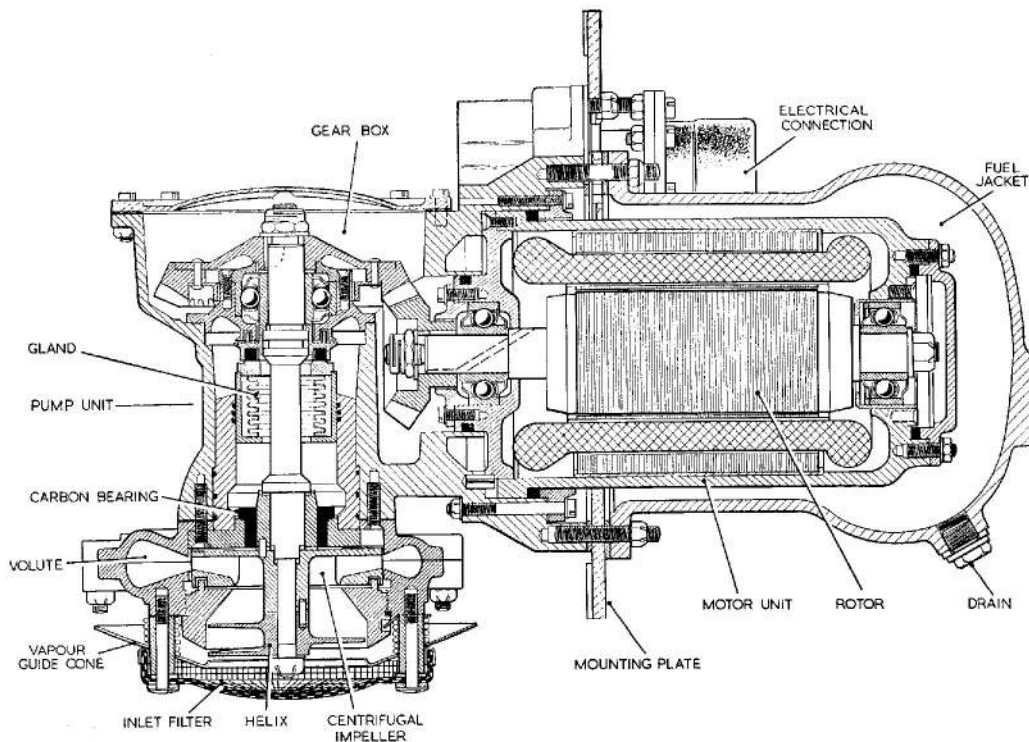

Fig. 1. Sectional view of SPE, 1234 Mk. 2 fuel pump

RESTRICTED

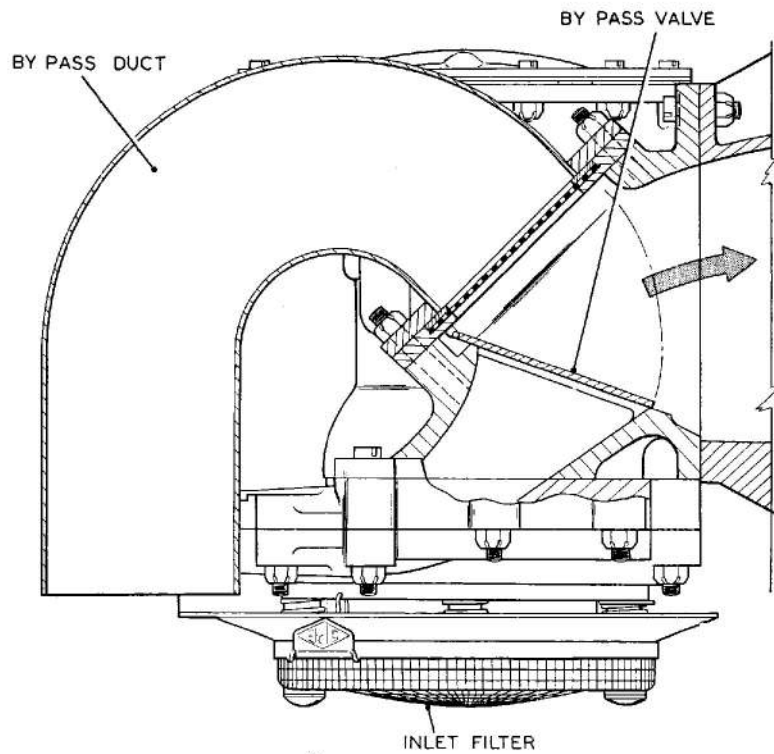

Fig. 2. Sectional view of SPE. 1234 Mk. 2 by-pass valve

RESTRICTED



Appendix 2

PUMPS, FUEL, SPE.1235

LIST OF ILLUSTRATIONS

	Fig.
Sectional view of SPE.1235, Mk. 2 fuel pump	1
Sectional view of SPE.1235, Mk. 2 bypass valve	2

LEADING PARTICULARS

Pump, fuel, Type SPE.1235 Mk. 1	Ref. No. 5UE/6713
Pump, fuel, Type SPE.1235 Mk. 1A	Ref. No. 5UE/6713
Pump, fuel, Type SPE.1235 Mk. 1B	Ref. No. 5UE/7512
Pump, fuel, Type SPE.1235 Mk. 1D	Ref. No. 5UE/
Pump, fuel, Type SPE.1235 Mk. 2	Ref. No. 5UE/6713
Pump, fuel, Type SPE.1235 Mk. 3	Ref. No. 5UE/7493
Pump, fuel, Type SPE.1235 Mk. 5	Ref. No. 5UE/
Operating voltage	200V. 3-phase, a.c.
Frequency 400 c/s
Motor unit	...	Fuel cooled: consequent wound 4-pole laminated construction.		
Rated output at operating voltage	1200 gal./hr.
Minimum fuel delivery pressure at rated output/operating voltage				
Mk. 1 only	11.75 lb./in. ²
All Mk. except Mk. 1	12.75 lb./in. ²
Max. current consumption at rated output/operating voltage				
Mk. 1 only	1.6A
All Mk. except Mk. 1	1.7A
Maximum 'no flow' delivery pressure at 200V., 400 c/s	22.0 lb./in. ²
Minimum 'no flow' delivery pressure	See Fig. 8. basic chapter.
Electrical connection	Special
Phase connections	Red (1)—to pin 1. Yellow (2)—to pin 2. Blue (3)—to pin 3.
Delivery outlet	1½ in. B.S.P.
Gland drain	¼ in. B.S.P.
Weight of unit				
Mk. 1 only	13.75 lb.
All Mk. except Mk. 1	13.5 lb. approx.

RESTRICTED

Introduction

1. The type SPE.1235 fuel pump is of the base flush mounting right-angled drive type as described in para. 15-17 of the basic chapter. Illustrations showing the main features of this type of pump will be found at the end of this appendix.

Type differentiation

2. Basic differences between the various marks of SPE.1235 pump are as follows:—

SPE.1235 Mk. 1

Basic design.

SPE.1235 Mk. 1A

Generally as Mk. 1 but the motor unit windings redesigned.

SPE.1235 Mk. 1B

Generally as Mk. 1A but gear box and terminal board chamber covers redesigned to include bonded rubber gaskets. Type of gear chamber lubricant changed.

SPE.1235 Mk. 1D

Generally as Mk. 1B but fitted with a redesigned gear and pinion. Further change of specified gear chamber lubricant.

SPE.1235 Mk. 2

Internal design similar to the Mk. 1A pump but the main pump body castings redesigned to reduce the weight of the pump. It is not economically possible to convert a Mk. 1A pump to Mk. 2 standard.

SPE.1235 Mk. 3

Generally similar to Mk. 2 but gear box and terminal board chamber covers redesigned to include bonded rubber gaskets. Type of gear chamber lubricant changed.

SPE.1235 Mk. 5

Generally as Mk. 3 pump but fitted with a redesigned gear and pinion. Further change of specified gear chamber lubricant.

Note . . .

SPE.1235 Mk. 1C and Mk. 4 were not produced.

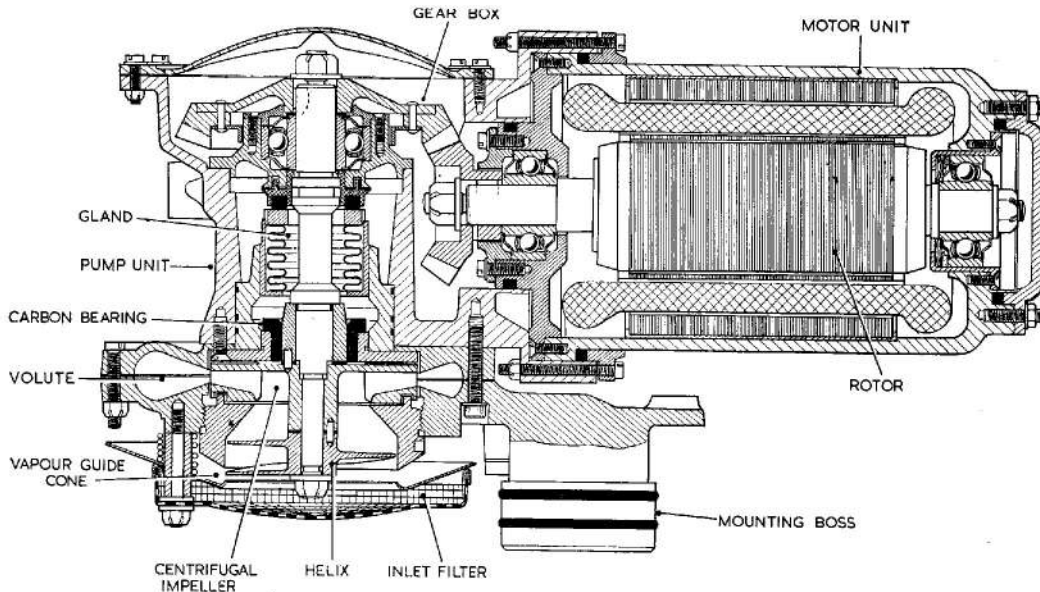

Fig. 1. Sectional view of SPE. 1235 Mk. 2 fuel pump

RESTRICTED

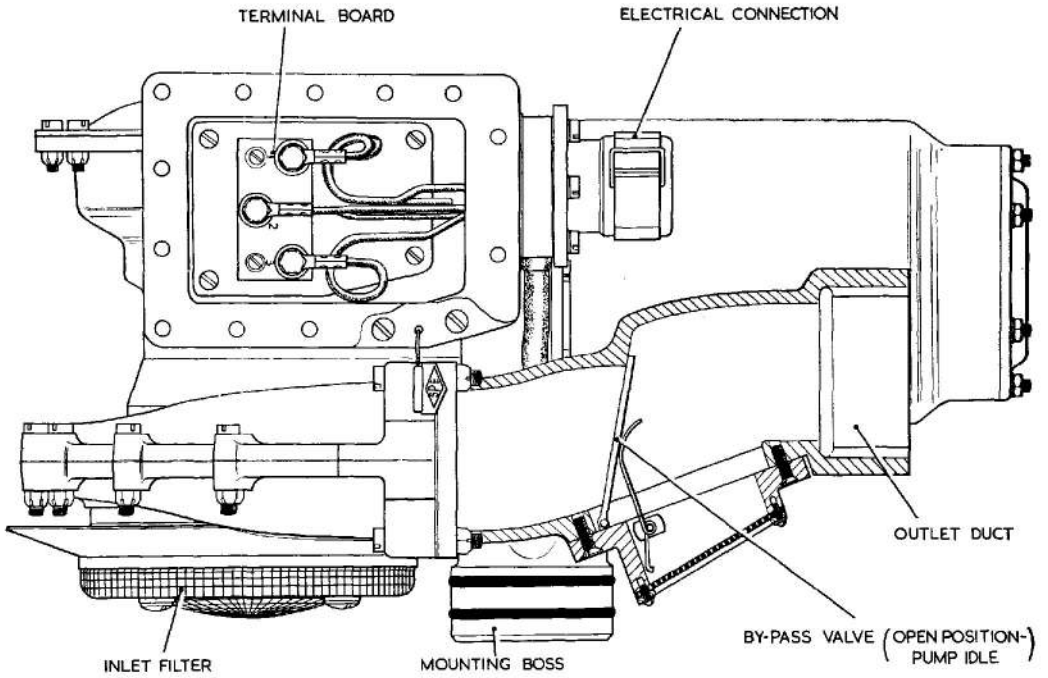
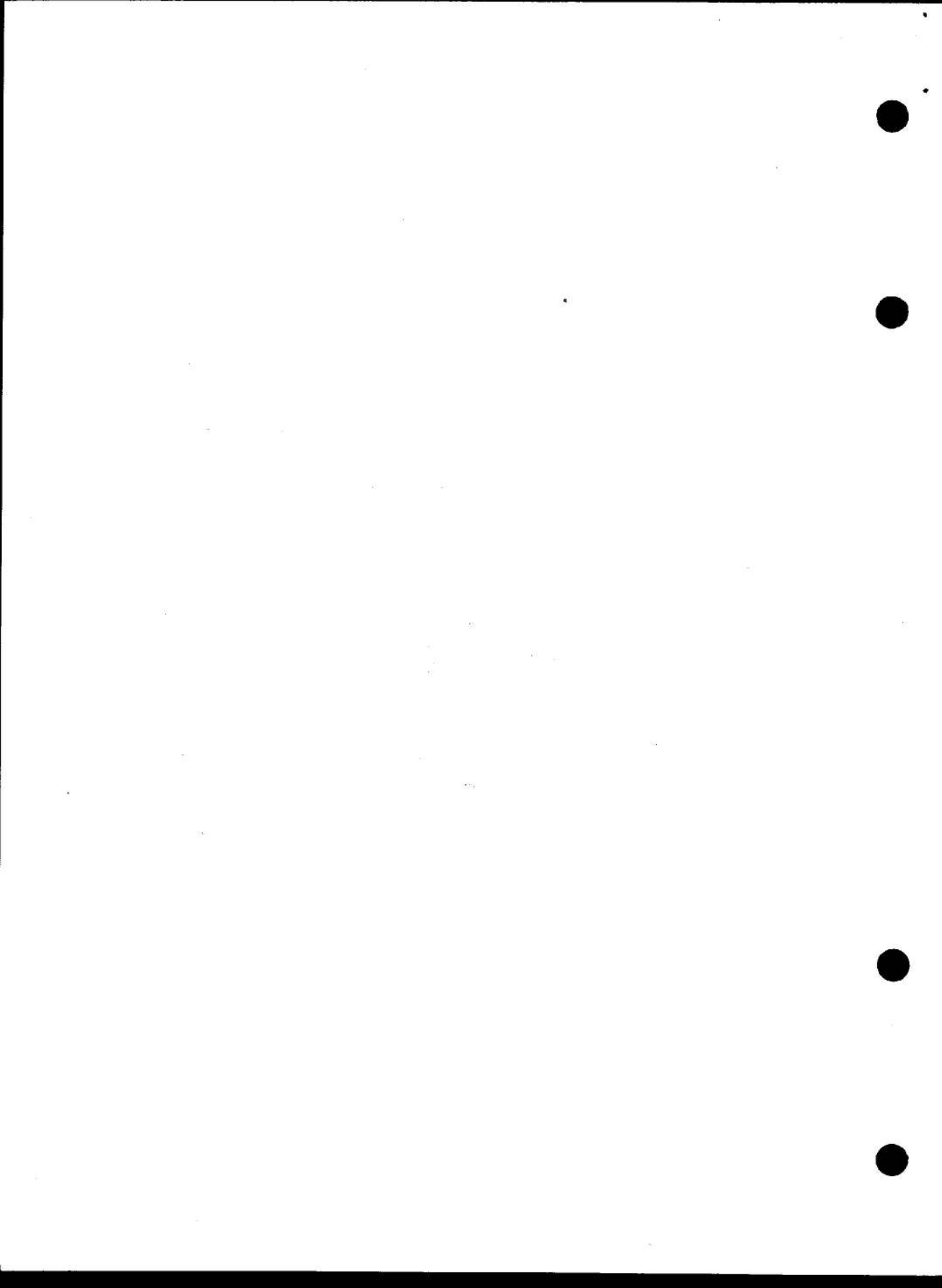

Fig. 2. Sectional view of SPE. 1235 Mk. 2 by-pass valve

RESTRICTED



Appendix 3

PUMPS, FUEL, SPE.1236

LIST OF ILLUSTRATIONS

	Fig.
Sectional view of SPE.1236, Mk. 2 fuel pump	1
Sectional view of SPE.1236, Mk. 2 by-pass valve	2
Sectional view of SPE.1236 gland drain	3

LEADING PARTICULARS

Pump, fuel, Type SPE.1236 Mk. 1	Ref. 5UE/6714
Pump, fuel, Type SPE.1236 Mk. 1A	Ref. 5UE/6714
Pump, fuel, Type SPE.1236 Mk. 1B	Ref. 5UE/7513
Pump, fuel, Type SPE.1236 Mk. 1D	Ref. 5UE/
Pump, fuel, Type SPE.1236 Mk. 2	Ref. 5UE/6714
Pump, fuel, Type SPE.1236 Mk. 3	Ref. 5UE/7494
Pump, fuel, Type SPE.1236 Mk. 5	Ref. 5UE/
Operating voltage	200V. 3-phase, a.c.
Frequency	400 c/s
Motor unit	...	Fuel cooled: consequent wound 4-pole laminated construction.			
Rated output at operating voltage	1200 gal./hr.
Minimum fuel delivery pressure at rated output/operating voltage					
Mk. 1 only	11.75 lb./in. ²
All Mk. except Mk. 1	12.75 lb./in. ²
Max. current consumption at rated output/ operating voltage					
Mk. 1 only	1.6A
All Mk. except Mk. 1	1.7A
Maximum 'no flow' delivery pressure at 200V., 400 c/s	22.0 lb./in. ²
Minimum 'no flow' delivery pressure	See Fig. 8, basic chapter.
Electrical connection	SPE.13920 (special)
Phase connections	Red (1)—to pin 1. Yellow (2)—to pin 2. Blue (3)—to pin 3.
Delivery outlet	Stud ring.
Gland drain	¼ in. B.S.P.
Weight of unit					
Mk. 1 only	16.5 lb.
All Mk. except Mk. 1	16.25 lb. approx.

RESTRICTED

Introduction

1. The type SPE.1236 fuel pump is of the base sump mounting, right-angled drive type as described in para. 18-20 of the basic chapter. Illustrations showing the main features of this type of pump will be found at the end of this appendix.

Type differentiation

2. Basic differences between the various marks of SPE.1236 pumps are as follows:—

SPE.1236 Mk. 1

Basic design.

SPE.1236 Mk. 1A

Generally as the Mk. 1 pump, but the motor unit windings redesigned.

SPE.1236 Mk. 1B

Generally as Mk. 1A but the gear box and terminal board chamber covers redesigned to include bonded rubber gaskets. The type of gear chamber lubricant changed.

SPE.1236 Mk. 1D

Generally as Mk. 1B but fitted with a redesigned gear and pinion. A further change of the specified gear chamber lubricant.

SPE.1236 Mk. 2

Internal design similar to the Mk. 1A pump but the main pump body castings redesigned to reduce the weight of the pump. It is not economically possible to convert a Mk. 1A pump to Mk. 2 standard.

SPE.1236 Mk. 3

Generally similar to the Mk. 2 pump, but the gear box and terminal board housing covers redesigned to include bonded rubber gaskets. Type of gear chamber lubricant changed.

SPE.1236 Mk. 5

Generally as the Mk. 3 pump, but fitted with a redesigned gear and pinion. Further change of specified gear chamber lubricant.

Note . . .

SPE.1236 Mk. 1C and Mk. 4 were not produced.

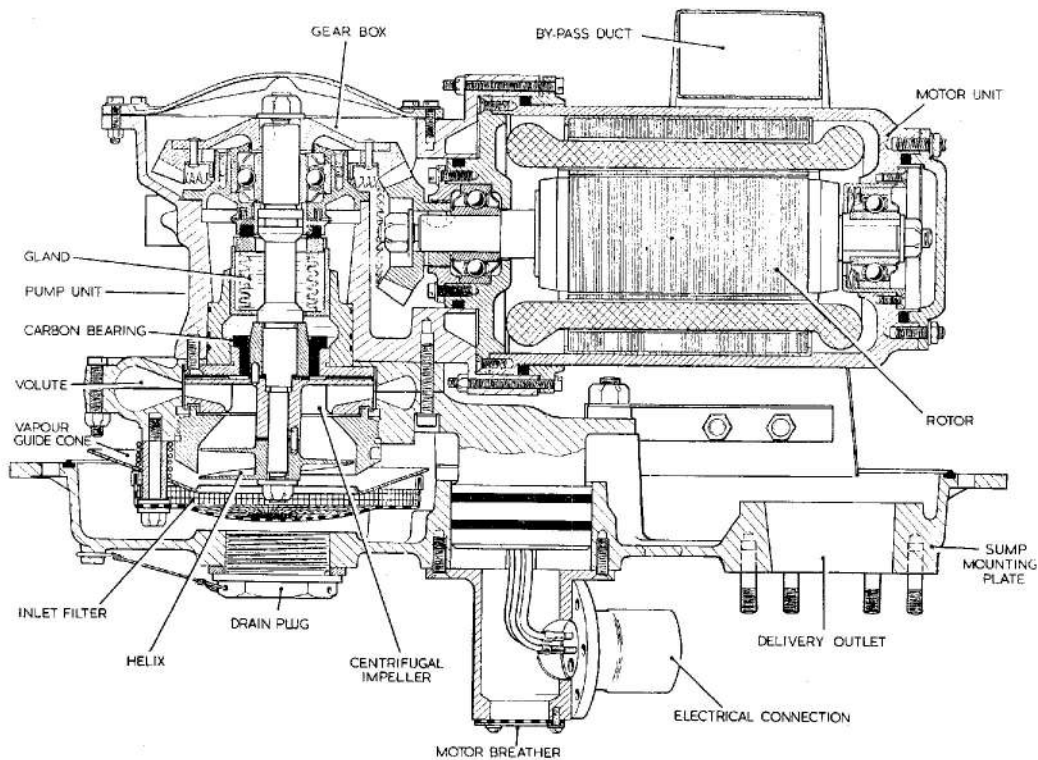

Fig. 1. Sectional view of SPE. 1236 Mk. 2 fuel pump

RESTRICTED

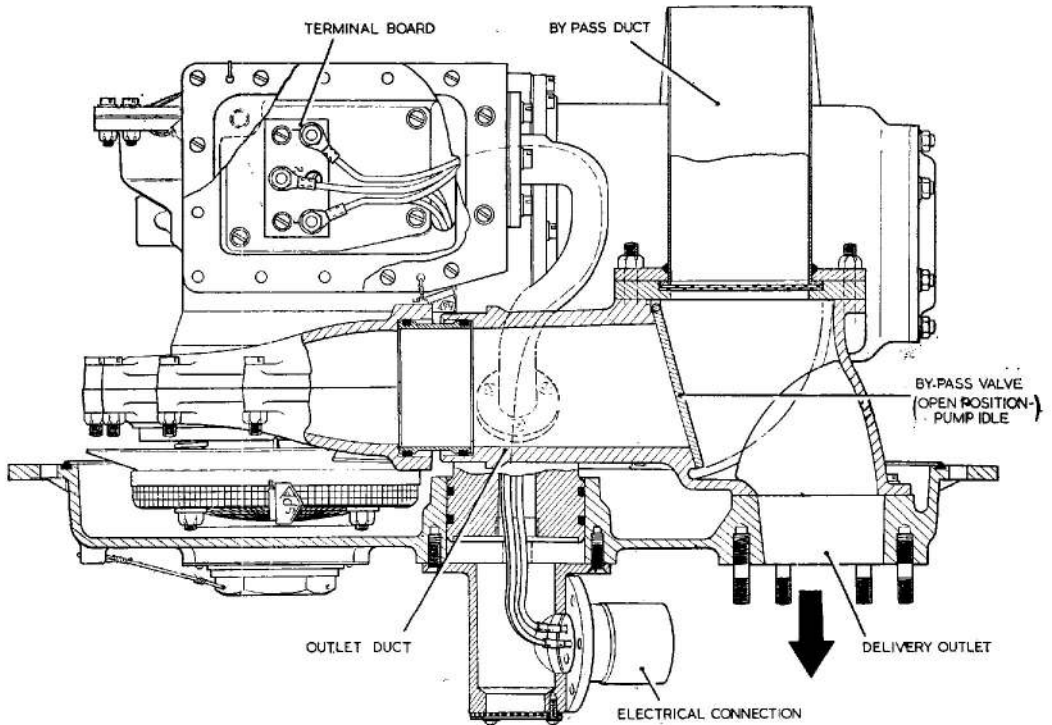

Fig. 2. Sectional view of SPE. 1236 Mk. 2 by-pass valve

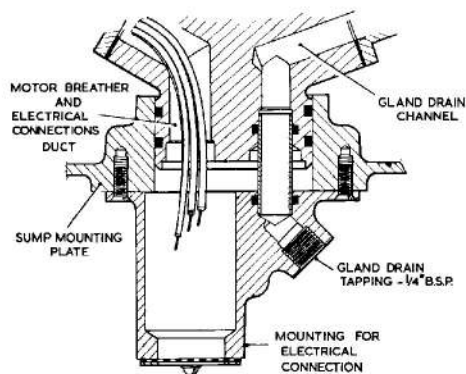

Fig. 3. Sectional view of SPE. 1236 gland drain

RESTRICTED



Appendix 4

PUMPS, FUEL, SPE.1237

LEADING PARTICULARS

Pump, fuel, Type	SPE.1237 Mk. 1	Ref. No. 5UE/6715
Pump, fuel, Type	SPE.1237 Mk. 1A	Ref. No. 5UE/6715
Pump, fuel, Type	SPE.1237 Mk. 1B	Ref. No. 5UE/7514
Pump, fuel, Type	SPE.1237 Mk. 1D	Ref. No. 5UE/
Pump, fuel, Type	SPE.1237 Mk. 2	Ref. No. 5UE/6715
Pump, fuel, Type	SPE.1237 Mk. 3	Ref. No. 5UE/7495
Pump, fuel, Type	SPE.1237 Mk. 5	Ref. No. 5UE/

Note . . .

SPE.1237 Mk. 1C and Mk. 4 were not produced.

Type differentiation

The SPE.1237 fuel pump comprises two Type SPE.1236 fuel pumps mounted on a common base sump mounting plate, as described in para. 18-20 and illustrated in Fig. 6 of the basic chapter. All connections are duplicated, and all data applicable to SPE.1236 pumps will apply to the individual pumps used in the SPE.1237 arrangement.

RESTRICTED



This file was downloaded
from the RTFM Library.
Link: www.scottbouch.com/rtfm
Please see site for usage terms,
and more aircraft documents.

