

Chapter 15

PUMP, FUEL, TYPE SPE.3536

LIST OF CONTENTS

	<i>Para.</i>		<i>Para.</i>
<i>Introduction</i>	1	<i>Starting check</i>	15
Description		<i>Installation</i>	16
<i>Pump unit</i>	2	Servicing	
<i>Motor unit</i>	7	<i>Routine inspection</i>	18
<i>Reduction gearing</i>	9	<i>Electrical test</i>	20
Operation	10	<i>'No fuel flow' test</i>	21
Removal and Installation		<i>Operational test</i>	24
<i>Removal</i>	13	<i>Gland leakage</i>	25
<i>Pre-installation checks</i>	14	<i>Insulation resistance test</i>	26

LIST OF ILLUSTRATIONS

	<i>Fig.</i>
<i>External view of SPE.3536 fuel pump</i>	1
<i>Sectional view of SPE.3536 fuel pump</i>	2
<i>Sectional view of outlet duct</i>	3
<i>Circuit diagram</i>	4

LIST OF TABLES

	<i>Table</i>
<i>Faults, possible causes and rectification</i>	1

LIST OF APPENDICES

	<i>App.</i>
<i>Pump, fuel, Type SPE.3536 Mk. 1</i> ...	1

RESTRICTED

Introduction

1. The fuel booster pump, Type SPE.3536 Mk. 1 (fig. 1), is designed to maintain the required fuel flow to the aircraft engine driven pump under the varying fuel temperature and altitude conditions experienced in flight. The unit is of the inclined, base sump mounting type and comprises a two-stage centrifugal pump driven through a right-angle bevel gearing by a 200-volt, 400 c/s, 3-phase a.c. motor.

DESCRIPTION

Pump unit

2. The two-stage centrifugal pump unit, shown sectioned in Fig. 2, is driven through right-angled bevel gearing, consisting of a

first stage helical impeller, and a second stage centrifugal impeller both of which are mounted on a common vertical shaft. This shaft is supported at its upper end by a shielded ball bearing and at its lower end in a plain carbon bearing lubricated by fuel. Fuel from the impeller system is fed into the volute and thereby into the main delivery line by way of an outlet channel cast into the pump mounting plate.

3. The main pump casting, housing the impeller system also contains the metallic bellows type gland preventing fuel ingress into the motor unit and gear chamber. Any slight leakage of fuel past this gland will be contained by shaft seals and a labyrinth type thrower arrangement, and drained through channels in the pump castings and external piping to atmosphere.

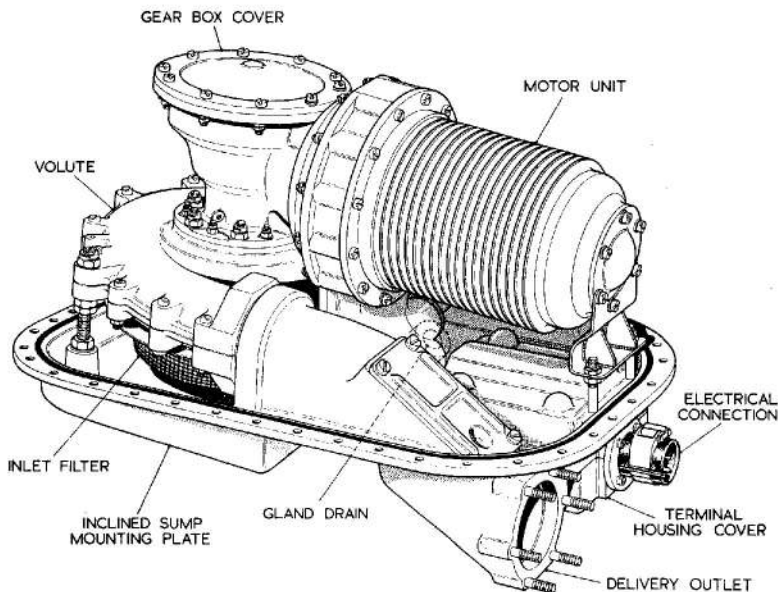

Fig. 1. External view of SPE.3536 fuel pump

RESTRICTED

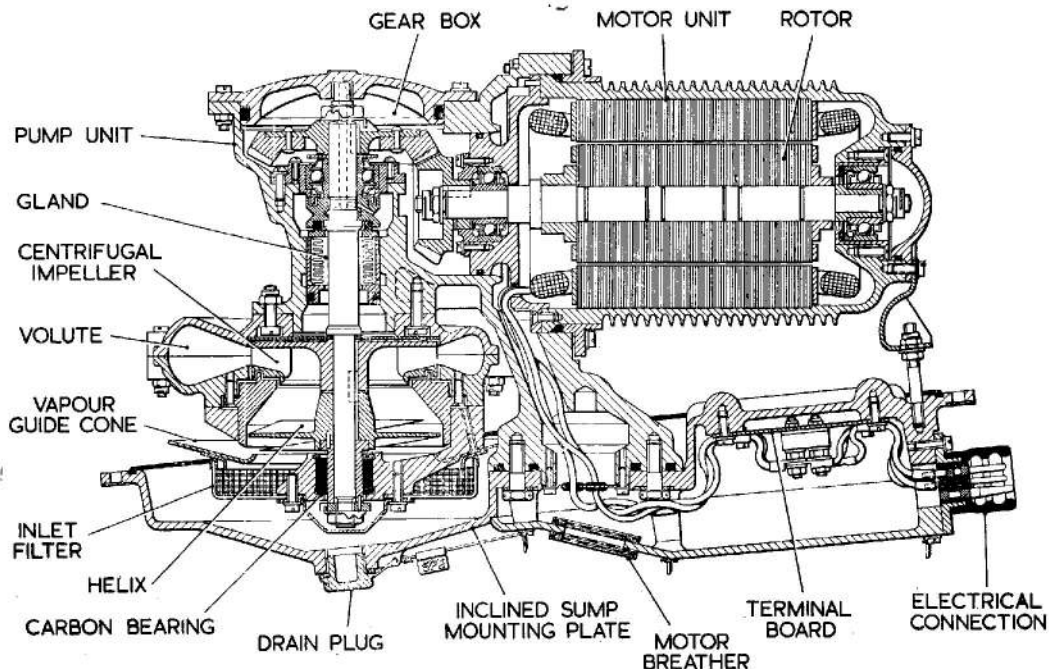

Fig. 2. Sectional view of SPE.3536 fuel pump

4. A wire mesh filter surrounding the fuel inlet to the pump prevents entry of foreign matter into the impeller system. Separation of fuel and air bubbles dissipated from the tips of the helix blades is assisted by a guide cone, fitted around this inlet.

5. The delivery outlet (*fig. 3*) of the volute assembly connects by means of an internal sleeve and seal rings with an outlet duct cast into the inclined sump mounting plate. The external fuel line connection to the mounting plate is by a stud ring. A simple flap valve in the outlet duct, normally held open by fuel pressure, serves to minimise reverse flow through the pump during re-fuelling operations.

6. The sump mounting plate is inclined, to suit the configuration of the aircraft fuel tank and is attached to the tank stud ring by 38 nuts. Sealing is effected by a synthetic rubber seal ring fitted to the upper surface of the mounting plate flange.

Motor unit

7. The motor unit is a totally enclosed, salient wound, six-pole laminated machine operating on a 200-volt, 400 c/s 3-phase a.c. aircraft supply. For the greater part of its

operating time the motor unit will be fully or partially immersed in fuel and dissipation of heat is facilitated by a finned casing.

8. The rotor is of a squirrel-cage construction and supported at each end in felt sealed ball-bearings pre-packed with XG295 grease Ref. No. 34B/9423152. The outer bearing assembly includes a pre-loaded washer to eliminate any end float in the rotor shaft.

Reduction gearing

9. The right angle bevel gearing gives a reduction of approximately 1.75 to 1 and comprises a steel bevel gear mounted to the pump shaft engaging a phosphor-bronze

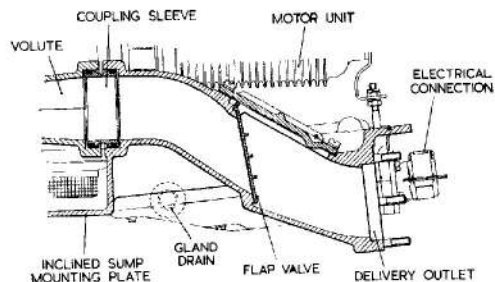

Fig. 3. Sectional view of outlet duct

RESTRICTED

pinion fitted to the motor unit. Lubrication of the gear is provided for during assembly and no further re-lubrication should be necessary between overhauls.

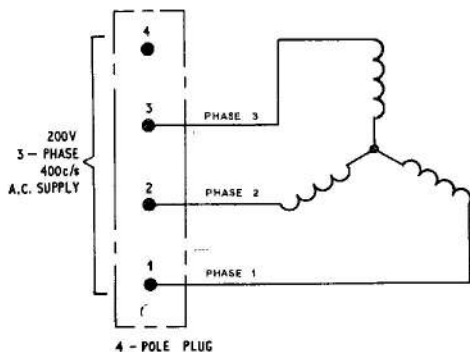

Fig. 4. Circuit diagram

OPERATION

10. Fuel from the tank enters the pump through a wire mesh filter and is picked up by a helical impeller which serves the dual purpose of de-aerating and pressurising the fuel at the eye of the centrifugal impeller. This latter impeller forces the fuel through the volute into the outlet duct and delivery line.

11. Under conditions in which the flow from the booster pump is low due to reduced engine requirements, the impeller continues to rotate at normal speed without causing any increase in fuel pressure.

12. In the event of a pump failure, fuel delivery pressure on the by-pass valve is relieved. As a result the valve opens and allows the engine driven pump to drain fuel at reduced pressure direct from the tank without passage through the pump impeller system.

REMOVAL AND INSERTION

Removal

13. Before attempting to remove a pump, check that the tank and associated delivery system has been drained of fuel by easing the drain plug in the base of the mounting plate assembly. Ensure that the aircraft electrical supply to the pump motor has been switched off. The precise method of removing the fuel pump will be detailed in the appropriate Aircraft Handbook. In general it will comprise the detachment of the fuel

delivery and gland drain pipes, the disconnection of the aircraft electrical socket by operating the quick-release clamp, and the detachment of the pump assembly from the thirty-eight studs of the tank mounting ring. The pump should be supported when carrying out this latter operation.

Pre-installation checks

14. The installation of a new pump should be preceded by the following checks:—

- (1) Ensure that the pump has not been stored for longer than the specified maximum period (i.e. 12 months in the original packing and carton as supplied by the manufacturers or 3 years where special packing has been provided).
- (2) Inspect the exterior of the pump for evidence of damage and security of pump locking wires. Check for any signs of corrosion, and where evident blend out and apply a protective finish (e.g. chromic acid solution) to the unprotected area.
- (3) Ensure that the pump is scrupulously clean externally.
- (4) Remove the transit plugs, caps and any other protective material from the delivery outlet, the electrical connection, the gland drain and the motor breather.

Starting check

15. It is advisable to make a starting check on the pump before installation. Apply a 200V., 3-phase a.c. supply through the electrical connection. The pump must start immediately. Repeat the test several times. If the pump fails to start immediately it should be returned to an overhaul base for further serviceability testing using approved equipment.

Installation

16. The above pre-installation checks apply to all aircraft installations of these pumps. For detailed procedure covering installation in a particular aircraft, reference should be made to the relevant Aircraft Handbook.

17. As a general example, installation in the aircraft will comprise the following operations:—

- (1) Ensuring that the seal ring in the periphery groove of the mounting plate flange is secure. It is fixed in position with rubber cement and should be removed at each overhaul of the pump or after any pump removal if it should show signs of damage or deterioration.

RESTRICTED

(2) Fitting the pump mounting plate to the tank bolt ring and securing it with thirty-eight nuts and lockwashers. Tighten diagonally opposite nuts in turn by degrees to ensure even compression of the seal ring

(3) Connecting the fuel delivery line to the stud ring on the mounting plate, using a gasket and an approved jointing compound to effect the seal.

(4) Connecting the gland drain pipe, ensuring when relevant that the open end of the latter faces towards the rear of the aircraft to prevent possible pressurisation in flight.

(5) Reconnecting the electrical supply plug to the pump socket. Secure the clamp.

(6) Wire-locking all pipe connections, union nuts, etc.

SERVICING

Routine inspection

18. At routine inspections the following procedure applies:—

(1) Inspect all the pipe connections and wire-locking to the pump. Check the joint between the pump and the fuel tank for leakage. Correct as necessary.

(2) Test the pump as detailed in para. 20-26. If the pump performance is found to be unsatisfactory in any way, the pump must be removed from the aircraft and a new or reconditioned unit fitted. No in-situ maintenance is possible.

(3) Ensure that the by-pass valve is functioning correctly by completing relevant tests detailed in the appropriate Aircraft Handbook.

19. At the periods laid down in the appropriate Servicing Schedules, all pumps are to be replaced by new or reconditioned units drawn from Stores. Faulty and time expired pumps must be returned to a Maintenance Unit or to the manufacturer for repair.

Electrical test

20. A routine electrical test in accordance with the appropriate Servicing Schedule should be made to ascertain that the motor unit is functioning satisfactorily. These tests must be made with the motor unit on load—i.e. immersed in and pumping fuel. The

pump must be replaced by a new or reconditioned unit if there is any indication of erratic performance such as excessive current consumption.

'No fuel flow' test

Note . . .

The following 'no fuel flow' electrical test is only applicable to aircraft with the necessary instrumentation. Where no test panel is provided, particular attention should be paid to the Electrical Test (para. 20) and to the Operational Test (para. 24).

21. Ascertain the position of the aircraft pump test socket and switches by reference to the relevant Aircraft Handbook. Proceed as follows:—

(1) Close all fuel cocks between the pump and engine to ensure that no fuel can flow.

(2) Connect a suitable portable ammeter to the socket on the test panel.

Note . . .

When using a clip-on type ammeter, open and close the tongs smartly prior to use to reduce the hysteresis errors.

(3) Switch on the pump by depressing the switch on the test panel. Observe the ammeter reading for a period of not less than 30 seconds.

22. Interpret the readings obtained as follows:—

(1) A steady reading, not exceeding that given for no-flow conditions in the appropriate appendix to this chapter, indicates that the motor is functioning satisfactorily.

(2) Current consumption in excess of the quoted figure indicates either a faulty motor unit, a rise in torque loading due to the obstruction of moving parts, or a restriction of the fuel flow.

(3) A fluctuating reading indicates faulty contacts, defective brushes, faulty commutation, or that bearings or other rotating parts are binding.

(4) A zero reading indicates an open circuit and is consistent with a blown

RESTRICTED

fuse, defective switch, faulty wiring or a complete motor failure.

23. When the above tests have been completed, release the test switch and disconnect the ammeter.

Operational test

24. Subject to the electrical test being completed satisfactorily, the pump should be tested where possible for proof of performance and checked against the performance figures quoted in the appropriate Appendix to this chapter. Refer to the relevant Aircraft Handbook for procedure details. Possible causes of failure to obtain the required performance are given in Table 1.

Gland leakage

25. During the above tests an examination should be made of the gland drain exit for fuel leakage. The leakage must not exceed a rate of two c.c. per hour when the pump is running, or one c.c. per hour when stationary. Any leakage in excess of these figures will necessitate removal of the pump from the aircraft.

Insulation resistance test

26. Using a 500V insulation resistance tester, measure the insulation resistance between the socket pins and the frame. When a new pump is drawn from Stores, the insulation resistance must not be less than 2 megohms. After installation, due to humidity conditions prevalent in aircraft at dispersal points, the minimum permissible insulation resistance is 50000 ohms.

TABLE 1

Fault	Possible cause	Rectification
Gland leakage	(1) Bad finish between gland seal surfaces. (2) Insufficient pressure between gland seal faces	All these conditions require that the pump is removed from the aircraft and returned to a Maintenance Unit or to the pump manufacturer for reconditioning.
Excessive current consumption	(1) Faulty motor unit (2) Excessive loading on metallic bellows gland (3) Fouling of impeller by foreign matter	
Low delivery pressure	(1) Faulty motor unit (2) Impeller impedance	
Pressure surge	(1) Tight or pre-loaded bearings (2) Excessive loading on bellows gland	
Low insulation resistance	(1) Dampness in motor windings	

RESTRICTED

Appendix 1

PUMP, FUEL, SPE.3536 Mk. 1

LEADING PARTICULARS

Pump, fuel, Type 3536 Mk. 1	Ref. No. 5UE/6750
<i>Operating voltage</i>	200V, 3-phase a.c.
<i>Frequency</i> 400 c/s
<i>Motor unit</i>	<i>Fuel cooled: salient wound 6-pole laminated construction</i>
<i>Rated output at operating voltage</i>	3500 gall./hr.
<i>Minimum fuel delivery pressure at rated output/voltage</i>	11.0 lb./in. ²
<i>Maximum current consumption at rated output/voltage</i>	4.25A
<i>Recommended maximum 'no flow' current consumption at 200V, 400 c/s</i>	4.3A
<i>Maximum 'no flow' delivery pressure at 200V, 400 c/s</i>	19.5 lb./in. ²
<i>Recommended minimum 'no flow' delivery pressure at 200V, 400 c/s</i>	17.0 lb./in. ²
<i>Electrical connection</i>	SPE.16368 (special)
<i>Phase connections</i>	Red (1)—to pin 1 Yellow (2)—to pin 2 Blue (3)—to pin 3
<i>Delivery outlet connection</i>	Stud ring on mounting plate
<i>Gland drain</i>	¼ in. B.S.P.
<i>Weight of unit</i>	26 lb. approx.

RESTRICTED

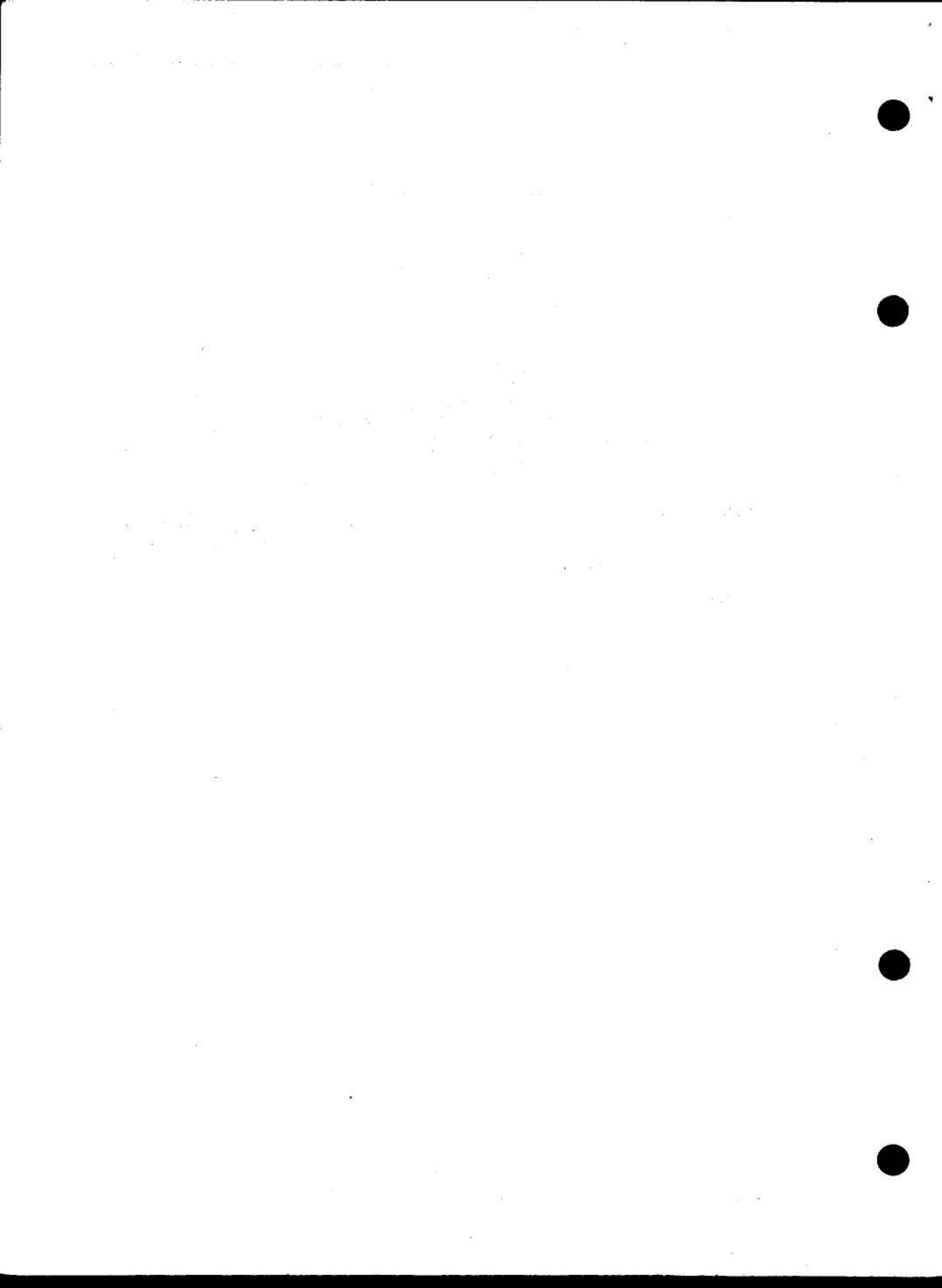

This file was downloaded
from the RTFM Library.

Link: www.scottbouch.com/rtfm

Please see site for usage terms,
and more aircraft documents.

