

Chapter 3

PUMP, FUEL, SPE.808

LIST OF CONTENTS

	<i>Para.</i>		<i>Para.</i>
<i>Introduction</i>	1	<i>Pre-installation checks</i>	13
Description		<i>Installation</i>	14
<i>General</i>	2	Servicing	
<i>Motor unit</i>	3	<i>Routine inspection</i>	16
<i>Pump unit</i>	4	<i>Electrical test</i>	18
<i>Mounting plate</i>	7	<i>'No fuel flow' electrical test</i>	19
Operation	8	<i>Operational test</i>	22
Removal and installation		<i>Gland leakage</i>	23
<i>Removal</i>	11	<i>Insulation resistance test</i>	24

LIST OF TABLES

	<i>Table</i>
<i>Faults, possible causes and rectification</i>	1

LIST OF ILLUSTRATIONS

	<i>Fig.</i>		<i>Fig.</i>
<i>External view of typical SPE.808 fuel pump</i>	1	<i>Circuit diagram</i>	4
<i>Sectional view of SPE.808 Mk. 3 pump</i>	2	<i>'No fuel flow' electrical test graph (Low speed)</i>	5
<i>Section through by-pass valve and electrical connection</i>	3	<i>'No fuel flow' electrical test graph (High speed)</i>	6

LIST OF APPENDICES

	<i>App.</i>
<i>Pumps, fuel, Type SPE.808 Mk. 2 and Mk. 3</i>	1

Introduction

1. Type SPE.808 electrically driven fuel booster pumps are designed to meet aircraft installation requirements where the fuel tank depth is restricted in thin wing sections. The pumps are for operation on 112V d.c. aircraft supply and are of the base sump mounting type. With this type of

mounting the use of a sump or dished mounting plate enables the fuel tank to be completely drained either by the action of the pump or by the removal of a drain plug in the mounting plate. The electrical connection to the pump is made externally through a socket on this mounting plate. Details of the differences between the mark

RESTRICTED

numbers of SPE.808 fuel pumps together with the Leading Particulars are given in appendices to this chapter.

DESCRIPTION

General

2. A typical SPE.808 fuel pump is illustrated in Fig. 2. The basic design consists of a horizontally mounted motor driving a vertical pump shaft through reduction gearing and comprises three main sub-assemblies as follows :

- (1) The motor unit.
- (2) The pump unit.
- (3) The mounting plate.

tion, provision being made for external switching of the shunt leads by connecting a variable resistance in the motor field circuit. Brush gear is of unit construction comprising four brushes, two either side in tandem producing two brush tracks. The armature shaft is supported by two ball bearings both of which are pre-packed during manufacture with an anti-freeze/high melting point grease and cannot be re-lubricated. A bevel gear on the extended armature shaft engages with a larger bevel gear on the pump shaft to drive the pump impeller system. These gears give a speed reduction of 2 : 1. The complete motor unit is enclosed in a fuel tight light alloy casing and clamped horizontally in position to the pump body.

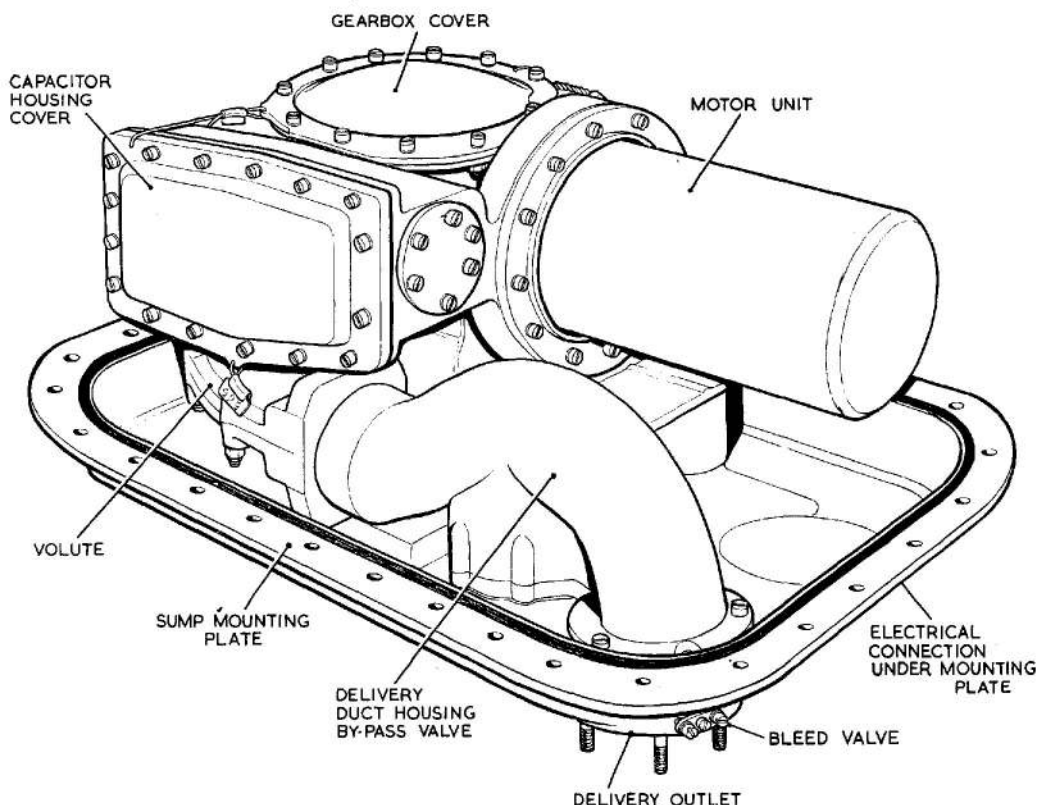

Fig. 1. External view of typical SPE.808 fuel pump

Motor unit

3. The SPE.808 motor unit is a totally enclosed, compound wound, two pole machine provided with radio interference noise suppression capacitors in a separate compartment of the main pump body casting. The motor unit is wired for two speed opera-

Pump unit

4. The two stage centrifugal pump unit, which is driven through the right-angled bevel gearing, comprises a first stage helical impeller and a second stage five-vaned centrifugal impeller mounted on a common shaft. This shaft is supported at its upper

RESTRICTED

vertical end by a shielded ball bearing and at its lower end in a plain carbon bearing lubricated by the fuel. Fuel from the impeller system is fed into a spiral volute and thence through a delivery outlet casting into the delivery line to the engine driven pumps.

5. The main casting or pump body, housing the impeller system, also contains the metallic bellows type seal unit which prevents the fuel ingress into the gear chamber and motor unit. Any slight fuel leakage past this gland will be dissipated by a thrower ring incorporated in the shaft machining, and on later mark numbers by an additional labyrinth type seal, and drained to atmosphere through drain channels in the pump castings.

6. Foreign matter is prevented from entering the pump impeller system by a wire mesh filter which encloses the fuel inlet to the pump. A vapour guide cone surrounding the fuel inlet to the impeller system assists in separating air and fuel vapour dissipated from the tips of the impeller helix. A simple hinged-plate by-pass valve is fitted in the delivery outlet casting and enables the engine-driven fuel pump to draw fuel from the tank when the booster

pump is idle. This valve is normally held closed by the pressure of the fuel in the delivery outlet.

Mounting plate

7. The SPE.808 pump and motor unit assembly is mounted to a dished sump-type mounting plate through an extension of the lower volute casting of the pump body. The fuel delivery line connection is made outside the tank to a stud ring in the base of this sump and a special carrier assembly, incorporating the motor breather, is provided for the electrical connection. Fitted in the delivery outlet under the mounting plate is a bleed valve which can be used to regulate the fuel delivery pressure during bench testing of the pump. This enables pumps, being fitted to the same aircraft fuel system, to be matched for performance.

OPERATION

8. When the pump motor is energised, fuel from the tank is drawn into the eye of the helical and centrifugal impellers and then forced through the spiral volute and delivery outlet castings into the fuel delivery line.

9. Under conditions in which the flow from the pump is low due to reduced engine requirements, the impellers continue to rotate at approximately normal speed with-

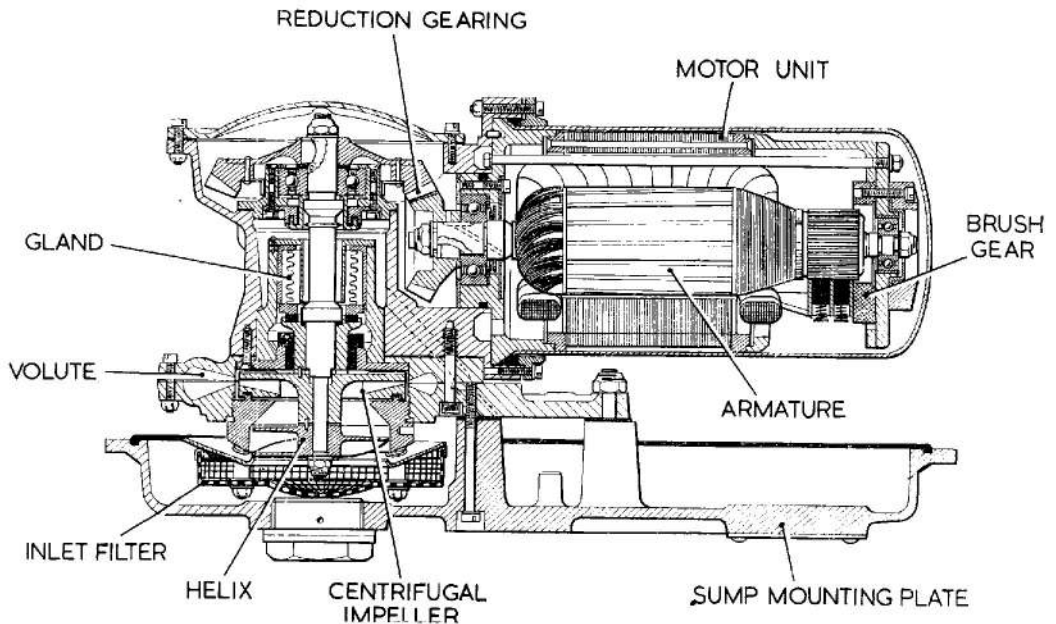

Fig. 2. Sectional view of SPE.808 Mk. 3 pump

RESTRICTED

out causing any excessive increase in fuel delivery pressure.

10. When the pump is idle, the delivery pressure on the top of the by-pass valve flap is relieved. The suction of the engine driven pump causes the valve to open and fuel passes directly from the tank into the fuel delivery line without passing through the booster pump impeller system.

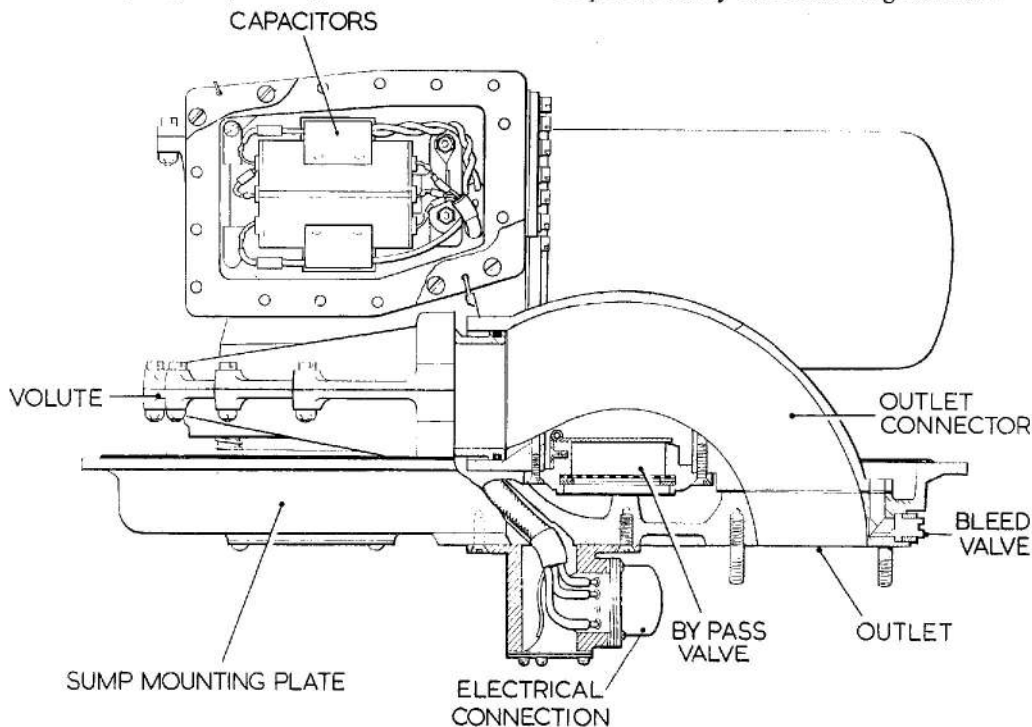

Fig. 3. Section through by-pass valve and electrical connection

REMOVAL AND INSTALLATION

Removal

11. Before attempting to remove a pump ensure that the tank has been drained of fuel and that the electrical supply to the pump motor has been switched off. The former can be checked by easing the drain plug in the pump mounting plate. The drain plug is provided with a drilled drainage hole through which any fuel remaining in the tank will flow before the plug is fully withdrawn.

12. The precise method of removing an SPE.808 fuel pump is detailed in the appropriate Aircraft Handbook. In general terms it will consist of disconnecting the fuel delivery pipe from the pump outlet stud ring or from a tapped elbow casting

fitted to this stud ring, together with the electrical connection and the gland drain pipe. The pump can then be removed by removing the thirty-four lock nuts from the studs of the tank mounting ring. Care should be taken to support the weight of the pump during this operation.

Pre-installation checks

13. The installation of a new pump should be preceded by the following checks :

(1) Ensure that the pump has not been stored for longer than the specified maximum period (i.e. 12 months in the original packing and carton as supplied by the manufacturer, or 3 years where special packing has been provided). Pumps stored for periods in excess of these maxima must not be used without being dismantled, examined and tested as detailed in Volume 6.

(2) Inspect the exterior of the pump for evidence of damage and for the security of all locking wires. Check the general cleanliness and for corrosion. Blend out slight areas of corrosion and apply an approved protective finish (chromic acid solution) to the unprotected area.

RESTRICTED

(3) Check that transit plugs or caps have been removed from the delivery outlet stud ring, gland drain connection and electrical connection socket, and remove any tape or any other protective material from the pump inlet filter and motor breather gauzes.

(4) It is advisable to make a starting check on the pump before installation. Lubricate the carbon pump shaft bearing by pouring a small quantity of fuel through the small holes in the pump casting at seal level, care being taken to ensure that fuel does not contaminate the electrical connection, or flow into the gland drain or motor breather ducts. Apply a 112V d.c. electrical supply through the socket on the underside of the mounting plate. The pump must start immediately. Repeat the test several times. If the pump fails to start immediately it must be returned to an overhaul base for further testing using approved equipment.

Installation

14. The above pre-installation checks apply to all aircraft installations of these pumps. For detailed procedure covering installations in a particular aircraft, reference should be made to the relevant Aircraft Handbook.

15. As a general example, installation in the aircraft will comprise the following operations :—

- (1) Checking that the seal ring in the periphery groove of the mounting plate is secure. This seal ring is fixed in position with rubber cement and must be secure over its full length. Lubricate the seal ring with a smear of an approved grease.
- (2) Securing the pump to the tank stud ring with thirty-four nuts and lock washers. Tighten the nuts in turn by degrees to ensure even compression of the seal ring.
- (3) Reconnecting the fuel delivery connection either to the stud ring in the mounting plate or to a screwed elbow already in position.
- (4) Reconnecting the gland drain pipe, ensuring when relevant that the

open end of the latter faces towards the rear of the aircraft to prevent possible pressurisation in flight.

(5) Reconnecting the electrical supply to the socket on the pump mounting plate.

(6) Wire locking all pipe connections, union nuts, etc.

SERVICING

Routine inspection

16. At routine inspections the following procedure applies :—

(1) Inspect all the pipe connections and wire-locking to the pump. Check particularly the joint between the pump mounting plate and the tank stud ring for signs of fuel leakage. Correct where possible.

(2) Test the pump as detailed in para. 18-24. If the pump performance is found to be unsatisfactory in any way, the pump must be removed from the aircraft and a new or reconditioned unit fitted. No in-situ maintenance is possible.

(3) Ensure that the by-pass valve is functioning correctly. This can be done by turning on the tank selector cock and the appropriate engine master cock. Switch on the pump and observe the fuel pressure indicated by the aircraft fuel pressure gauge or warning light. Very low pressure on the gauge or failure to extinguish the warning light indicates that the by-pass valve is not functioning efficiently.

Note . . .

In certain installations the fuel pressure warning light may be set to operate at a higher pressure than that at which the pump is rated. The warning light setting for the particular installation should therefore be checked before rejecting a suspect pump, by reference to the appropriate Aircraft Handbook.

17. At the periods laid down in the appropriate Servicing Schedules, all pumps are to be replaced by new or reconditioned units drawn from Stores. Faulty and time

RESTRICTED

expired pumps must be returned to a Maintenance Unit or to the manufacturer for repair.

Electrical test

18. A routine electrical test in accordance with the appropriate Servicing Schedule should be made to ascertain that the motor unit is functioning satisfactorily. These tests must be made with the motor unit on load—i.e. immersed in and pumping fuel. The pump must be replaced by a new or reconditioned unit if there is any indication of erratic performance such as excessive current consumption,

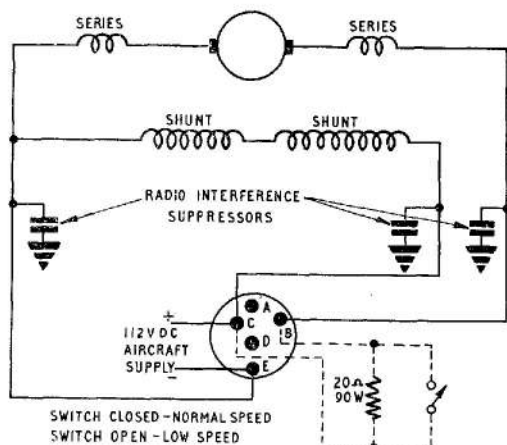

Fig. 4. Circuit diagram

'No fuel flow' electrical test

Note . . .

The following 'No fuel flow' electrical test is only applicable to aircraft with the necessary instrumentation. Where no test panel is provided, particular attention should be paid to the electrical test (para. 18) and to the operational test (para. 22).

19. Ascertain the position of the aircraft pump test socket and switches by reference to the relevant Aircraft Handbook. Proceed as follows:—

- (1) Close all fuel cocks between the pumps and engines to ensure that no fuel can flow.
- (2) Connect a suitable portable ammeter to the coil or socket provided on the test panel.

Note . . .

When using a clip-on type ammeter the tongs should be opened and

closed smartly when taking readings to reduce the hysteresis errors. These errors may be considerable if the value of the coil is increasing or decreasing slowly.

- (3) Switch on the pump by depressing the switch on the test panel. Observe the ammeter reading for a period of not less than 30 seconds.

20. Interpret the readings obtained as follows:—

- (1) A steady reading not exceeding that indicated by the graphs (Fig. 5 and 6) for the measured applied voltage, indicates that the motor unit is functioning satisfactorily.

Note . . .

The graphs (fig. 5 and 6) are provided as a guide to pump performance under 'no flow' conditions: the figures derived from them are not to be interpreted as forming a part of the approved Acceptance Test Specification for the pump.

- (2) Current consumption in excess of the graph reading indicates either a faulty motor unit, a rise in torque loading due to the obstruction of moving parts, or a restriction of the fuel flow.
- (3) A fluctuating reading indicates faulty contacts, defective brushes, faulty commutation or that bearings or other rotating parts are binding.
- (4) A zero reading indicates an open circuit and is consistent with a blown fuse, defective switch, faulty wiring or a complete motor failure.

21. When the above tests have been completed satisfactorily, release the test push switch on the test panel and disconnect the ammeter.

Operational test

22. Subject to the electrical test being completed satisfactorily, the pump should be tested where possible for proof of performance and checked against the performance figures quoted in the appropriate appendix to this Chapter. Refer to the relevant Aircraft Handbook for procedure details. Possible causes of failure to obtain the required performance are given in Table 1.

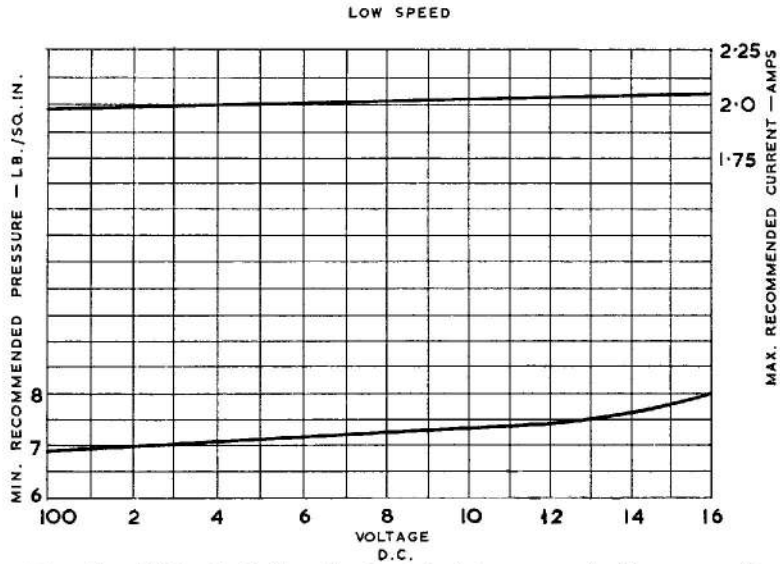

Fig. 5. "No fuel flow" electrical test graph (Low speed)

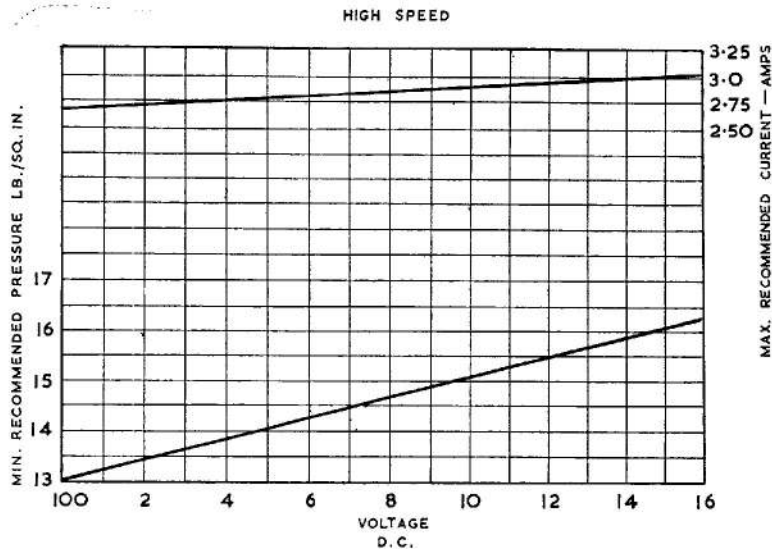

Fig. 6. "No fuel flow" electrical test graph (High speed)

Gland leakage

23. During the above tests an examination should be made of the gland drain exit for fuel leakage. The leakage must not exceed two drops per minute while the pump is running, or one drop per minute while stationary. Any leakage in excess of these figures will necessitate removal of the pump from the aircraft.

Insulation resistance test

24. Using a 250 volt constant pressure insulation resistance tester measure the insulation resistance between the socket pins and the frame. When a new pump is installed the insulation resistance should not be less than 2 megohms. After installation for operational service, due to the humidity prevalent in aircraft at dispersal points, the insulation resistance must not be less than 50,000 ohms.

TABLE 1
Faults, possible causes and rectification

Fault	Possible causes	Rectification
Gland leakage	<ul style="list-style-type: none"> (1) Bad finish between gland seal faces. (2) Insufficient pressure between gland seal faces. (3) Cracked carbon. 	All these conditions require that the pump is removed from the aircraft and returned to a Maintenance Unit or to the manufacturer for reconditioning.
Excessive current consumption	<ul style="list-style-type: none"> (1) Faulty motor unit. (2) Excessive loading on metallic bellows gland. (3) Fouling of impeller by foreign matter. (4) Faulty bearings. (5) Incorrect meshing of gears. 	
Very high current	<ul style="list-style-type: none"> (1) Short circuit. 	
Low or fluctuating current	<ul style="list-style-type: none"> (1) Faulty motor unit. 	
Low delivery pressure	<ul style="list-style-type: none"> (1) Faulty motor unit. (2) Impeller impedance. 	
Pressure surge	<ul style="list-style-type: none"> (1) Tight or pre-loaded bearings. (2) Excessive loading on bellows gland. 	
Low insulation resistance	<ul style="list-style-type: none"> (1) Dampness in motor windings. 	

RESTRICTED

Appendix 1

PUMPS, FUEL, TYPE SPE.808 MK. 2 AND MK. 3

Pump, fuel, Type SPE.808 Mk. 2	Stores Ref. 5UE/6214
Pump, fuel, Type SPE.808 Mk. 3	Stores Ref. 5UE/6522
Voltage limits	100/116V d.c.
Rated voltage	112V d.c.
Rated output at 112V d.c. (High speed)	400 gal./hr.
Rated output at 112V d.c. (Low speed)	200 gal./hr.
Delivery pressure at rated output/voltage (High speed)	14.5 lb./in ² . (min.)
Delivery pressure at rated output/voltage (Low speed)	7.0 lb./in ² . (min.)
Max. current consumption at rated output/voltage (High speed)	2.9A
Max. current consumption at rated output/voltage (Low speed)	2.0A
Max. 'no-flow' delivery pressure at 116V d.c. (High speed)	19.0 lb./in ² .
Minimum 'no-flow' delivery pressure	See Fig. 5 and 6, basic chapter	
Electrical connection (Plessey 2CZ.111401)	Ref. No. 5X/7142
Delivery outlet	Stud ring
Gland drain tapping	$\frac{1}{4}$ in. B.S.P.
Weight of unit	15 lb. approx.

Type differentiation

1. Basic differences between the various marks of SPE.808 pumps covered by this appendix are as follows:

- SPE. 808 Mk. 2* Basic production design covered in chapter.
- SPE. 808 Mk. 3* Generally similar to SPE.808 Mk. 2 but incorporating a venting between the motor unit and the gear box. An improved thrower arrangement in-

cluding labyrinth type seal and a fuel trap to contain bellows seal leakage under negative "g" conditions has been introduced. The clearance between the bellows seal body and the carbon seal is increased to avoid seizure hazards during high altitude operations.

RESTRICTED





This file was downloaded from the RTFM Library.

Link: www.scottbouch.com/rtfm

Please see site for usage terms, and more aircraft documents.

