

## Chapter 6

## PUMPS, FUEL, SPE. 1200 SERIES

## LIST OF CONTENTS

	Para.		Para.
<i>Introduction</i> ... ..	1	<i>Inclined sump mounting fuel booster pumps</i> ... ..	23
<i>Pump mountings</i> ... ..	3	<i>Operation</i> ... ..	26
<i>Description</i>		<i>Removal and installation</i> ... ..	29
<i>Typical pump and motor unit assembly</i>	4	<i>Servicing</i>	
<i>Motor unit</i> ... ..	5	<i>Routine inspection</i> ... ..	32
<i>Pump unit</i> ... ..	9	<i>Electrical test</i> ... ..	34
<i>Type descriptions:</i>		<i>'No fuel flow' electrical test</i> ... ..	35
<i>Side mounting fuel booster pumps</i> ...	13	<i>Operational test</i> ... ..	38
<i>Base flush mounting fuel booster pumps</i>	17	<i>Gland leakage</i> ... ..	39
<i>Base sump mounting fuel booster pumps</i>	20	<i>Insulation resistance test</i> ... ..	40

## LIST OF ILLUSTRATIONS

	Fig.
<i>Typical fuel tank pump mountings</i> ... ..	1
<i>Typical Spe.1200 series pump and motor unit assembly</i> ... ..	2
<i>Typical side mounting fuel booster pump</i>	3
<i>Typical base flush mounting pump</i> ... ..	4
<i>Typical base sump mounting fuel booster pump</i> ... ..	5
<i>Typical inclined sump mounting fuel booster pump</i> ... ..	6

## LIST OF APPENDICES

	App.
<i>Pumps, fuel, SPE.1204 Mk. 1, 2 and 3</i> ...	1
<i>Pumps, fuel, SPE.1207 Mk. 1 and 2</i> ...	2
<i>Pumps, fuel, SPE.1214 Mk.1, 1A, 2 and 3</i>	3
<i>Pumps, fuel, SPE.1215 Mk.1, 1A and 2</i> ...	4
<i>Pumps, fuel, SPE.1216 Mk.1 and 2</i> ... ..	5

RESTRICTED

### Introduction

1. The SPE.1200 series of electrically driven fuel booster pumps are designed to maintain the required fuel supply to the aircraft engine driven pump under the varying fuel temperature and altitude conditions experienced in flight. The pumps are for operation on 112 volts d.c. aircraft supply and all internal electrical circuits include built-in radio noise suppressors. The nominal delivery rating of the SPE.1200 series pumps is 1200 gallons per hour.

2. All the pumps in this series are of the right-angled drive type to suit installation requirements where fuel tank depth is restricted by thin wing sections or other considerations. The method of mounting the pump - side, base flush or base sump - constitutes one of the main differences between basic types of pump in each series (*para. 3*).

### Pump mountings

3. The different types of mounting are illustrated in Fig. 1 and may be defined as follows:-

- (1) **Side mounting.**- Provision is made for including in the assembly a mounting plate for securing the pump to the side of the tank so that the pump unit is within the tank with the motor unit protruding. The electrical connection to the pump motor is made externally.
- (2) **Base flush mounting.**- With this type of mounting the pump is wholly within the fuel tank and bolted to a cast mounting plate secured to a stud ring in the base of the tank. The electrical connection to the pump motor is through a special fuel tight electrical connection on the pump casting.

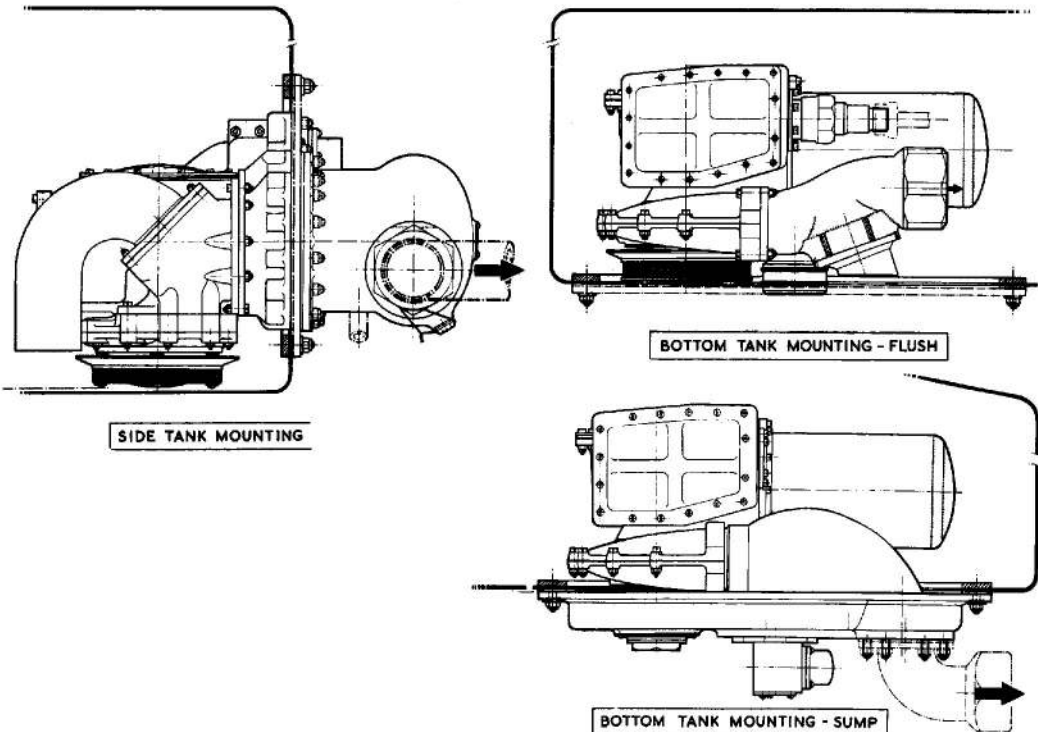

Fig. 1. Typical fuel tank pump mountings

**RESTRICTED**

- (3) **Base sump mounting.**— The use of a sump or dished mounting plate for the pump enables the fuel tank to which it is fitted to be completely drained, either by the action of the pump or by removal of a drain plug located in the mounting plate. The electrical connection to the pump is made externally.
- (4) **Inclined sump mounting.**— Similar to the Base sump mounting, but it is designed for use where the tank bottom is angled to suit the configuration of the aircraft.

### DESCRIPTION

#### Typical pump and motor unit assembly

4. A typical pump and motor unit assembly is illustrated in Fig. 2. This basic arrangement is common to all 112 volts d.c. SPE.1200 series pumps except for minor casting profile details to suit the various installation configurations.

#### Motor unit

5. The motor units fitted to these pumps are suitable for a 112 volts d.c. aircraft supply. All motor units are totally enclosed compound wound machines using a conventional two pole construction. The armature laminations are skewed.
6. In a typical motor the armature shaft is supported by shielded bearings, the bearing at the commutator end being retained in a steel sleeve. The shaft drive is fitted with a bevel pinion which engages with a bevel gear on the pump shaft, providing a reduction of approximately 2:1.
7. The brush gear is of unit construction, comprising four brushes, two either side in tandem producing two brush tracks. The type and position of the electrical connection varies with the mounting arrangement.
8. The motors are generally wired for single speed operation, although certain

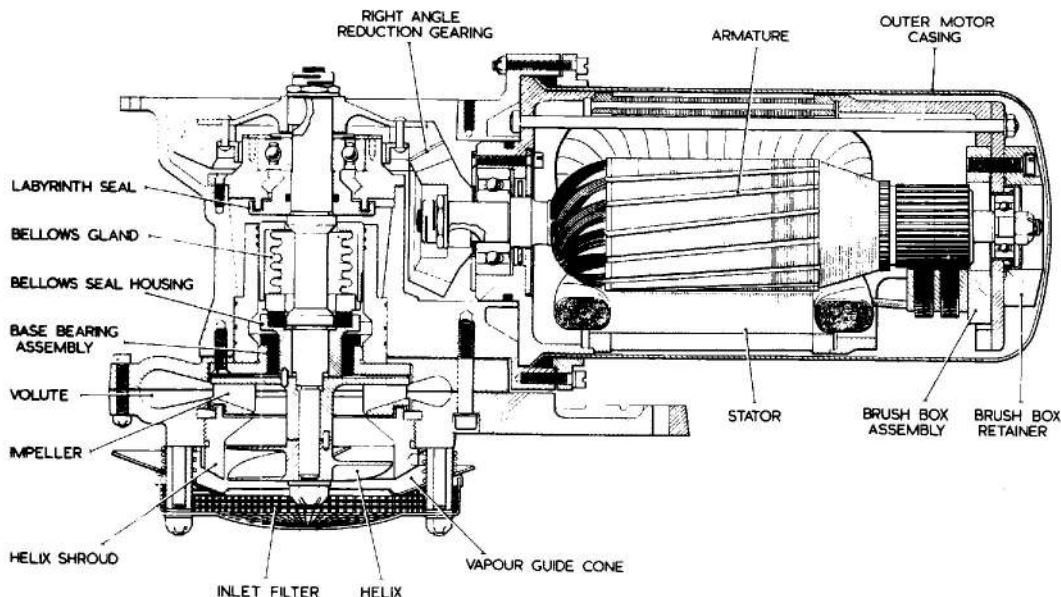

Fig. 2. Typical SPE.1200 series pump and motor unit assembly

RESTRICTED

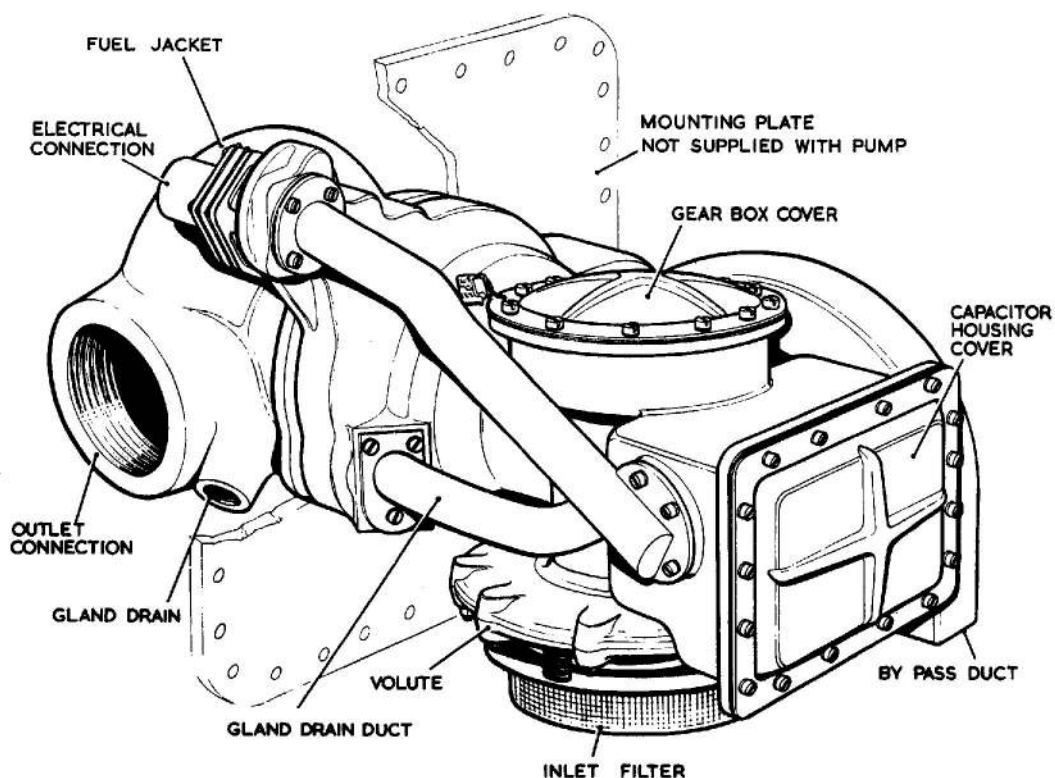

Fig. 3. Typical side mounting fuel booster pump

SPE.1200 series pumps were originally designed for use as two speed machines with provision for externally switching the shunt loads. The internal electrical circuits include radio noise suppressors, but the positioning of these varies with the mounting configuration.

#### Pump unit

9. The two stage centrifugal pump unit, which is driven through the right-angled bevel gearing, comprises a first stage helical impeller and a second stage centrifugal impeller mounted to a common vertical shaft. This shaft is supported at its upper end by a shielded ball-bearing and at its lower end in a plain carbon bearing lubricated by fuel. Fuel from the impeller system is fed into a spiral volute and thence to the delivery line.

10. The main casting or pump body housing the impeller system also contains the metallic bellows type seal unit preventing fuel ingress into the motor unit and gear chamber. Any slight fuel leakage past this gland will be dissipated by a thrower ring incorporated in the shaft machining and drained to atmosphere through drain channels in the pump castings.

11. Foreign matter is prevented from entering the pump unit by a wire mesh filter which encloses the inlet. A vapour guide cone surrounding the inlet to the impeller system assists in separating the fuel and air bubbles dissipated from the tips of the impeller helix.

12. The delivery outlets from the volute chamber differ in each mounting arrange-

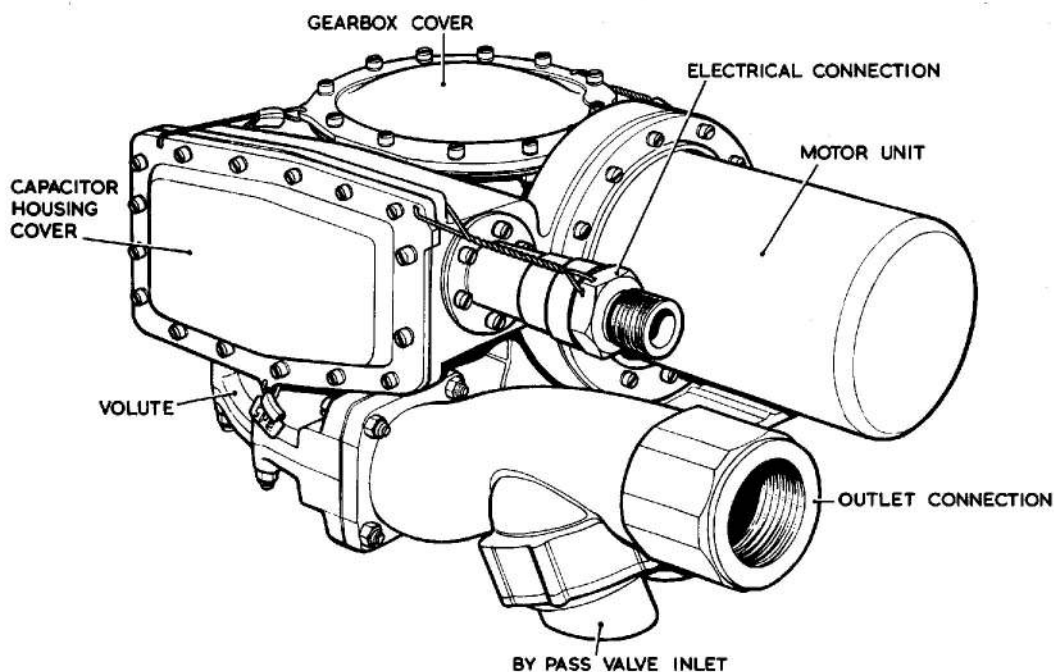

Fig. 4. Typical base flush mounting pump

ment. All pumps in the series are however fitted with a simple hinged-plate by-pass valve at some point in or adjacent to the delivery outlet which enables the engine driven pump to draw fuel from the tank in the event of booster pump failure. The valve is normally held closed by booster pump pressure.

#### Type description

13. Side mounting fuel booster pumps.— In a typical side mounting SPE.1200 series fuel booster pump, the pump and motor unit are basically as described in para. 4-12, but the pump shaft is slightly longer to suit installation requirements.

14. The fuel delivery line is connected outside the tank to either of two horizontally opposed  $1\frac{1}{2}$  in. B.S.P. outlet connection on the fuel jacket surrounding the motor unit. This fuel jacket also includes

a  $\frac{1}{4}$  in. B.S.P. gland drain tapping, the channel to which is incorporated in the casting and mates with a similar duct in the main pump body. A by-pass valve is mounted over the delivery duct and is backed by a fabricated duct formed so that the end is immersed in fuel until the tank is almost empty.

15. Radio interference suppressors are contained in a housing on the end of the main pump body casting and the electrical connection is made to a Plessey plug fitted to an external mounting surface of the pump casting.

16. Side mounting fuel pumps are normally supplied without a mounting plate or associated gaskets. The fuel jacket is attached in a few positions only with additional nuts supplied in a separate package.

**RESTRICTED**

17. **Base flush mounting fuel booster pump.**—The SPE.1200 base flush mounting fuel booster pumps, are fitted with a pump and motor unit basically as described in para. 4-12.

18. The fuel delivery line is connected within the tank to a 1½ in. B.S.P. outlet casting, which includes the by-pass valve enabling fuel to be drawn from the tank when the booster pump is idle. A mounting flange and boss is provided for bolting the pump to a tank mounting plate (not normally supplied with pump). Both the gland drain and the motor breather channels are brought to the outside of the tank through this mounting boss.

19. The electrical connection to the pump is made within the fuel tank and is of a special flameproof and fuel tight

design. The radio noise suppressors are contained in a housing on the side of the main pump body casting.

20. **Base sump mounting fuel booster pumps.**—In a typical base sump mounting SPE.1200 series fuel booster pump, both the pump and the motor unit are basically as described in para. 4-12.

21. The pump is bolted to a dished sump type mounting plate, through an extension of the lower volute casting. The fuel delivery line connection is made outside the tank to a stud ring in the base of the sump, and the by-pass valve which enables fuel to be drawn from the tank when the pump is idle is included in the connector casting assembly linking the pump volute to the sump outlet.

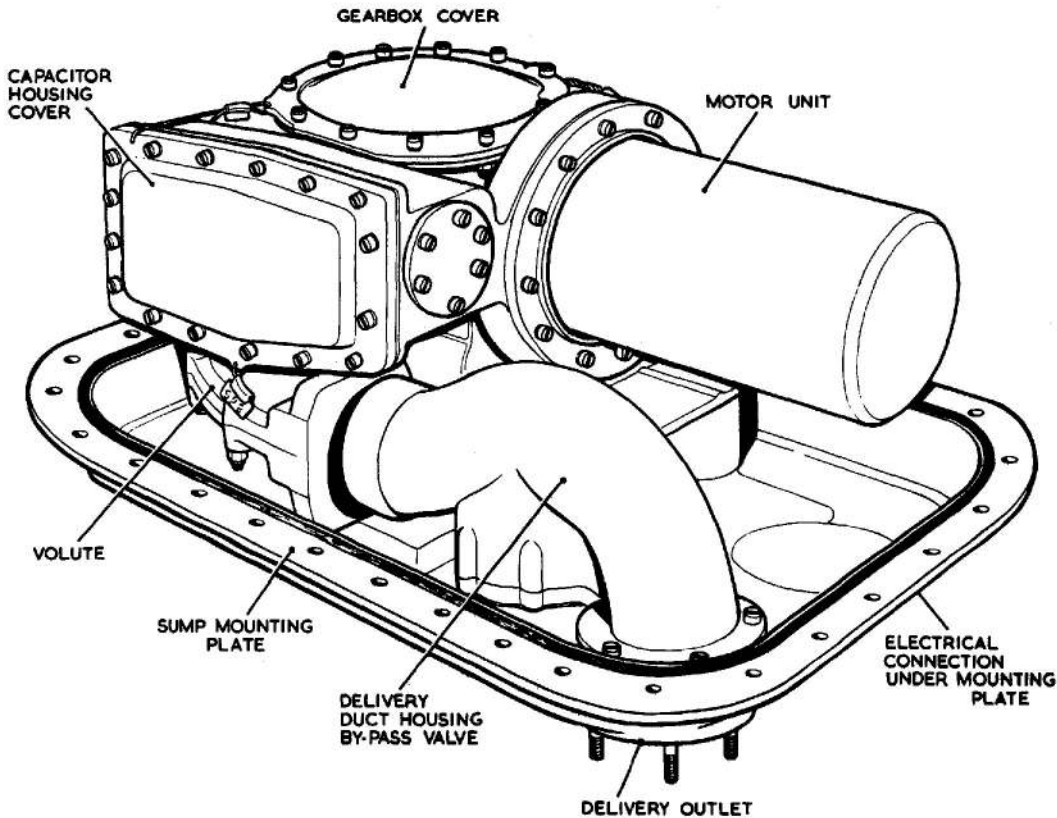

Fig. 5. Typical base sump mounting fuel booster pump

**RESTRICTED**

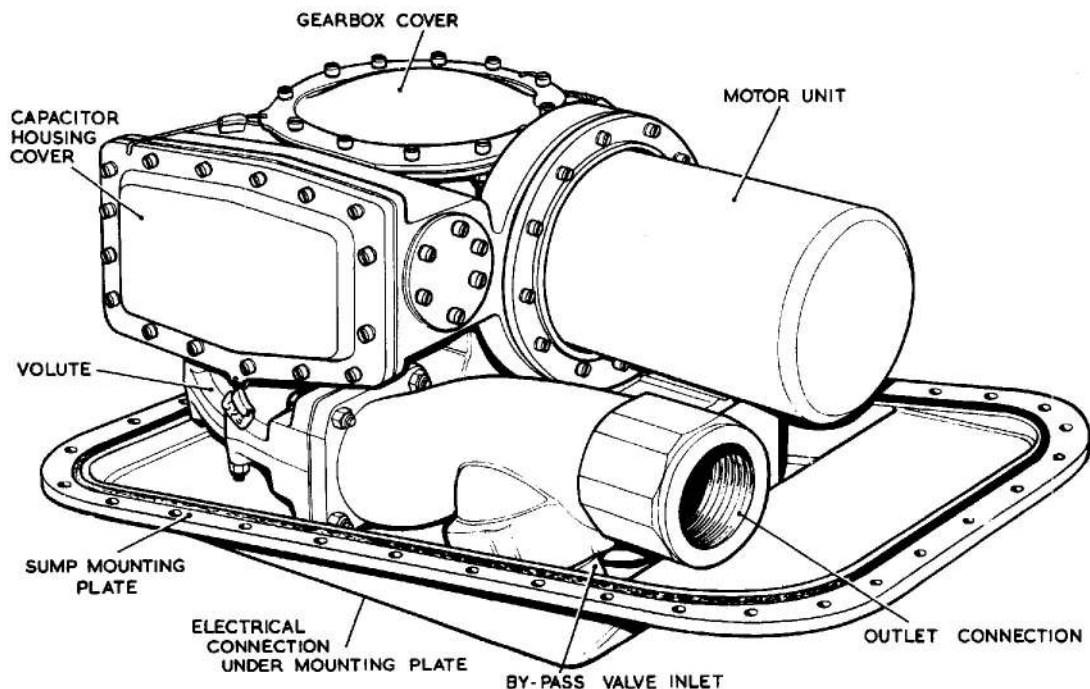

Fig. 6. Typical inclined sump mounting fuel booster pump

22. The electrical connection to the pump is made externally through a "Breeze" plug fitted to a special carrier assembly secured to the undersurface of the sump mounting plate. This carrier casting also incorporates the motor breather. Radio noise suppressors are contained in a housing in the side of the main pump body casting.

23. **Inclined sump mounting fuel booster pumps.**— The inclined sump mounting Type SPE.1200 series fuel booster pumps are fitted with a pump and motor unit basically as described in para. 4-12.

24. The pump is bolted to an inclined dished sump type mounting plate through an extension of the lower volute casting. The fuel delivery line is connected within the tank to a 1½ in. B.S.P. outlet casting which includes the by-pass valve enabling

fuel to be drawn from the tank when the booster pump idles.

25. The electrical connection is made externally through a "Breeze" plug secured to a housing on the sump mounting plate. This mounting plate is fitted with a special water drain valve, and the gauze protected outlet of the motor breather channel. Radio noise suppressors are contained in a housing in the side of the main pump body casting.

#### OPERATION

26. Fuel from the tank enters the pump through a wire mesh filter and is picked up by a helical impeller which serves the dual purpose of de-aerating and pressurising the fuel at the eye of the centrifugal impeller. This latter impeller feeds the fuel through the spiral volute chamber and thence into the outlet duct.

RESTRICTED

27. Under conditions in which the flow from the booster pump is low due to reduced engine requirements, the impeller continues to rotate at approximately normal speed without causing any excessive increase in the fuel pressure.

28. When the pump is idle the pressure on the by-pass valve is relieved. As a result the valve opens and allows the engine driven pump to draw fuel direct from the tank without passage through the pump impeller system.

#### REMOVAL AND INSTALLATION

29. Before attempting to remove a pump ensure that the tank has been drained of fuel and that the electrical supply to the pump motor unit has been switched off. The former can be checked by easing the tank drain plug which may be fitted either in the tank itself or on the pump mounting plate. The precise method of removing each type of pump will be detailed in the appropriate Aircraft Handbook. Generally it will comprise the disconnection of the fuel delivery pipe, the electrical connection and the gland drain connection. The pump can then be removed by disconnecting the pump mounting plate from the tank bolt ring. Care should be taken to support the weight of the pump during the latter operation.

30. The installation of a new pump should be preceded by the following checks:-

- (1) Ensure that the pump has not been stored for longer than the specified maximum period (i.e. 12 months in the original packing and carton as supplied by the manufacturer or 3 years where special packing has been provided).
- (2) Inspect the exterior of the pump for evidence of damage and security of pump locking wires. Check for any signs of corrosion. Blend out slight areas of corrosion and apply a protective finish (i.e. chromic acid solution) to the unprotected area.

(3) Ensure that the pump is scrupulously clean externally.

(4) Remove the transit plugs, caps and other protective material from the delivery outlet, the electrical connection, the gland drain and the motor breather.

(5) It is advisable to make a starting check on the pump before installation. To do this the carbon shaft bearing should be lubricated by pouring a small quantity of fuel through the small holes in the pump casting at seal level, care being taken to ensure that fuel does not contaminate the electrical connection or flow into the gland drain or motor breather ducts. Apply a 112 volts d.c. supply to the pump by means of the plug and socket connection. The pump should start immediately. Switch off the current and repeat the test several times. If the pump fails to start immediately, it should be returned to a repair base for further serviceability testing using approved equipment.

(6) The above pre-installation instructions apply to all aircraft installations of these pumps. For detailed procedure covering installations in a particular aircraft, reference should be made to the appropriate Aircraft Handbook.

31. As a general example installation in the aircraft will comprise the following operations:-

- (1) Ensure that new seal rings and gaskets are fitted where necessary to all pump/mounting plate or mounting plate/tank bolt ring joints. Note that the seal ring in the periphery groove of the base and sump mounting plates is fixed in position with rubber cement.
- (2) Connect the fuel delivery line, the electrical supply and the gland drain connections. These connections should be made either before or after offering the pump assembly to the tank bolt ring, being depen-

dent on whether these connections are inside or outside the fuel tank.

*Note...*

*The pipe from the gland drain should always face to the rear of the aircraft to prevent possible pressurisation in flight.*

- (3) Secure the pump mounting plate to the fuel tank bolt ring with the requisite number of nuts and lock washers. Tighten the nuts in turn to ensure even compression of the joint washers and seal rings.
- (4) Wire lock all internal and external connections to the pump assembly.

### SERVICING

#### Routine Inspection

32. At routine inspections care should be taken to conform to the following procedure:

- (1) Inspect all pipe connections and wire locking to the pump, and correct as necessary.
- (2) Test the pump as detailed in para. 34-40. If the pump is found to be defective it must be removed and a new or reconditioned pump fitted. No in-situ maintenance is possible.
- (3) Ensure that the by-pass valve is functioning correctly. To do this turn on the tank selector cock and the appropriate engine master cock. Switch on the pump and observe the fuel pressure indicated by the aircraft fuel pressure gauge or warning light. Very low pressure on the gauge or failure to extinguish the warning light indicates that the by-pass valve is not functioning efficiently. In certain installations the fuel pressure warning light may be set to operate at a higher pressure than that at which the pump is rated. The warning light setting for the particular installation should therefore be checked before rejecting a suspect pump.

33. At the periods laid down in the appropriate servicing schedules, all pumps are to be replaced by new or reconditioned pumps drawn from Stores. Faulty pumps must be returned to a Maintenance Unit, or to the manufacturer for repair.

#### Electrical test

34. A periodic electrical check in accordance with the appropriate Servicing Schedule should be made to ascertain that the motor is functioning satisfactorily. The pump must be replaced by a new or reconditioned pump if there is any indication of erratic performance such as excessive current consumption. These tests should only be made with the motor on load i.e. immersed in, and pumping fuel.

#### "No fuel flow" electrical test

35. Before applying the electrical test at "no fuel flow" ascertain the position of the aircraft pump test coil and switches by reference to the relevant Aircraft Handbook, when this has been done proceed as follows:

- (1) Close all fuel cocks between the pumps and engines to ensure that no fuel can flow.
- (2) Connect a clip on type ammeter, Ref. No. 5Q/38 to the coil provided on the test panel.

*Note...*

*Open and close the tongs smartly when taking readings as this reduces errors due to hysteresis which otherwise may be considerable if the value of the coil is increasing or decreasing slowly.*

- (3) Switch on the pump by depressing the test push-switch on the test panel, and note the reading of the ammeter for a period of not less than half-a-minute.

36. Interpret readings obtained as follows:

- (1) A steady reading not exceeding the given figure quoted for a particular pump in the appropriate appendix

to this Chapter indicates that the pump operation is satisfactory.

- (2) A reading in excess of those quoted in the appropriate appendix indicates either a faulty motor unit, a rise in torque loading due to the obstruction of moving parts or a restriction of the fuel flow.
- (3) A fluctuating reading indicates faulty brushes or commutator or that the bearings or other rotating parts are binding.
- (4) A zero reading indicates an open circuit and is consistent with a blown fuse, defective switch, faulty wiring or in extreme cases, a complete motor failure.

37. When the above checks have been completed, release the test push switch on the test panel and unclip the ammeter from the test coil.

#### Operational test

38. Subject to the electrical tests being satisfactory, the pump should be tested for proof of performance, and checked against the given figures quoted for a particular pump in the appropriate appendix to this

Chapter. Failure to obtain the quoted pressures and rate of fuel delivery could be caused by a faulty motor unit, a damaged impeller, or an incorrect loading of the pump unit bellows type gland unit. The pump should be removed to ascertain the cause of failure.

#### Gland leakage

39. During the above tests an examination should be made of the gland drain exit for fuel leakage. The leakage must not exceed two drops per minute while the pump is running or one drop per minute while stationary. Any leakage in excess of these figures will necessitate removal of the pump.

#### Insulation resistance test

40. Using a 250 volt constant pressure insulation resistance tester measure the insulation resistance between live parts and the frame. When a new pump is installed the insulation resistance should not be less than 2 megohms. After installation for operational service, due to the humidity prevalent in aircraft at dispersal points, the minimum insulation resistance permissible is 50,000 ohms.

## Appendix 1

## PUMPS, FUEL, SPE.1204 MK.1, 2 AND 3

## LIST OF CONTENTS

	Para.		Para.
Introduction ... ..	1	Type differentiation ... ..	2

## LIST OF ILLUSTRATIONS

	Fig.		Fig.
Sectional view of SPE.1204 Mk. 3 ... ..	1	Graph: Estimated current consumption and delivery pressure under no-flow conditions ... ..	4
Sectional view of SPE.1204 Mk. 3 by-pass ducting ... ..	2		
Circuit diagram ... ..	3		

## LEADING PARTICULARS

Pump, fuel, SPE. 1204 Mk.1 ... ..	Ref. No. 5UE/6226
Pump, fuel, SPE. 1204 Mk.2 ... ..	Ref. No. 5UE/6355
Pump, fuel, SPE. 1204 Mk.3 ... ..	Ref. No. 5UE/
Motor unit ... ..	112 volts d.c.: flameproof: radio interference suppressed: suitable for two speed operations.
Rated output ... ..	1200 g.p.h.
Fuel delivery pressure (at rated voltage) ... ..	11.0 lb./in. <sup>2</sup>
Rated voltage ... ..	112 volts d.c.
Maximum current consumption (under above conditions) ... ..	3.3 amps.
Voltage limits ... ..	100/116 volts d.c.
Electrical connection (Plessey CZ/50356) ... ..	Ref. No. 5X/6181
No-flow delivery pressure (max.) ... ..	Fig. 4.
New brush length (to centre of radius) ... ..	11.8 mm. (0.465 in.)
Minimum permissible brush length for re-fitting ... ..	10.6 mm. (0.417 in.)
Brush spring loading ... ..	4.5 oz. at 6.7-9.5 mm. (0.264-0.374 in.) compressed length
Minimum permissible commutator diameter for further use ... ..	24.0 mm. (0.945 in.)
Undercut commutator segments ... ..	0.036 in. wide x 0.020 in. deep
Maximum commutator eccentricity with shaft journals ... ..	0.001 in. (total)

RESTRICTED

### LEADING PARTICULARS (continued)

Motor unit bearings	... ..	Hoffman 106 PP Hoffman 112 PP (pre-packed with XG/295 grease)
Pump unit bearings	... ..	Hoffman 112 PP (pre-packed with XG/295 grease) Plain carbon - fuel lubricated
Delivery outlet	... ..	1½ in. B.S.P.
Gland drain	... ..	¼ in. B.S.P.
Weight of unit	... ..	16.5 lb. (Mk. 1) 16.75 lb. (Mk. 2 and 3)

**Note...**

*Dismantling the above pumps to inspect or replace brushes or bearings will necessitate full re-testing of the unit in accordance with the approved Schedule of Acceptance Tests.*

**Introduction**

1. The type SPE.1204 fuel pumps are of the side-mounting, right-angled drive type described in para. 13-16 of the basic chapter and suitable for 112 volts d.c. supply. Illustrations showing the main features of this type of pump will be found at the end of this appendix.

**Type differentiation**

2. Basic differences between the various marks of SPE.1204 pumps are as follows:-

- SPE.1204 Mk.1 ... Basic design
- SPE.1204 Mk.2 ... Generally as SPE.1204 Mk.1 but the electrical supply lead and the gland drain conduit are re-designed to reduce the overall width of the

pump to ease assembly into the aircraft tank.

SPE.1204 Mk.3 ... Generally as SPE.1204 Mk.2 but incorporating a venting between the motor unit and the gear box, an improved thrower arrangement including labyrinth seal, and a fuel trap to contain the bellows seal leakage under negative "g" conditions. The clearance between the bellows seal body and the carbon seal is increased to avoid seizure hazard during high altitude operations.

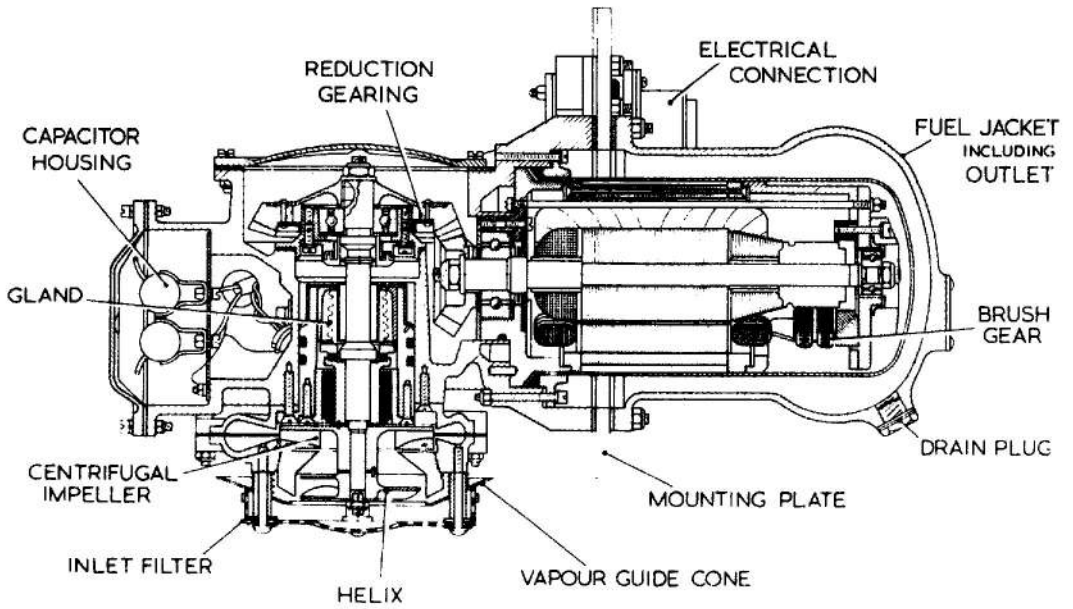

Fig. 1 Sectional view of SPE.1204 Mk.3

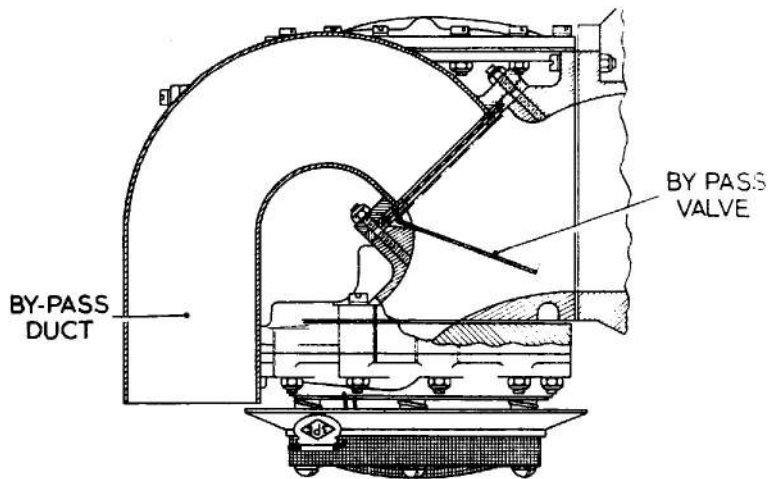

Fig. 2 Sectional view of SPE.1204 Mk.3 by-pass ducting

**RESTRICTED**

NOTE :- FOR NORMAL SPEED JOIN A TO B  
FOR LOW SPEED JOIN A TO D AND B TO C

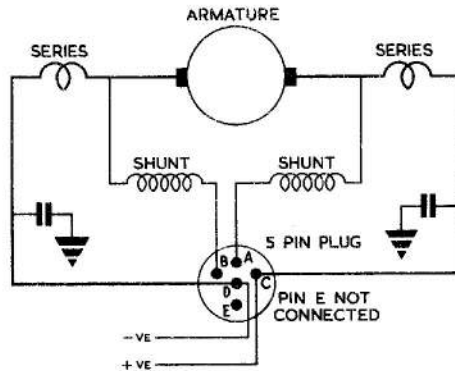

Fig. 3 Circuit diagrams

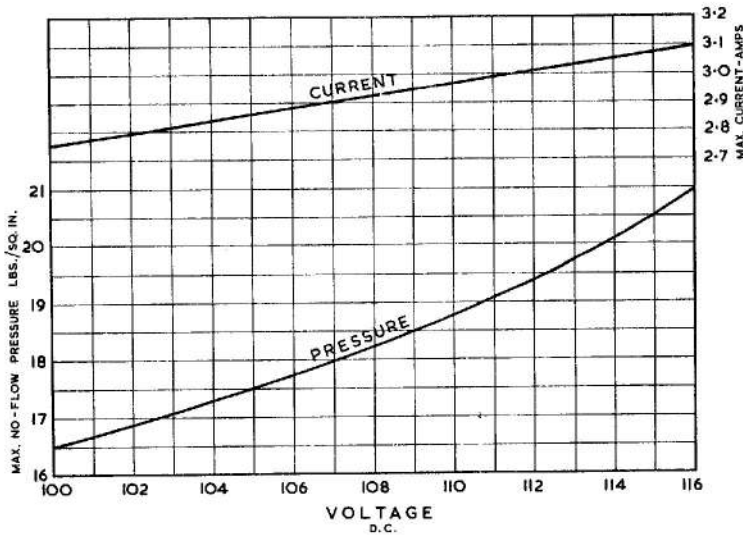

Fig. 4 Graph: Estimated current consumption and delivery pressure under no-flow conditions

**Note...**

The above graphs are provided as a guide to the pump performance under no-flow conditions and the figures derived from them at voltages other than 116 volts d.c. are not to be interpreted as forming part of the approved Acceptance Test Specification for the pump.

**RESTRICTED**

## Appendix 2

## PUMPS, FUEL, SPE.1207 MK.1 AND 2

## LIST OF CONTENTS

	Para.		Para.
<i>Introduction</i> ... ..	1	<i>Type differentiation</i> ... ..	2

## LIST OF ILLUSTRATIONS

	Fig.		Fig.
<i>Sectional view of SPE.1207 Mk.2</i> ... ..	1	<i>Graph: Estimated current consumption and delivery pressure under no-flow conditions</i> ... ..	4
<i>Sectional view of SPE.1207 Mk.2 outlet and by-pass assembly</i> ... ..	2		
<i>Circuit diagram</i> ... ..	3		

## LEADING PARTICULARS

<i>Pump, fuel, SPE.1207 Mk.1</i> ... ..	Ref. No. 5UE/6217
<i>Pump, fuel, SPE.1207 Mk.2</i> ... ..	Ref. No. 5UE/6217
<i>Motor unit</i> ... ..	112 volts d.c.: flameproof: radio interference suppressed: suitable for two speed operations.
<i>Rated output</i> ... ..	1200 g.p.h.
<i>Fuel delivery pressure (at rated voltage)</i> ... ..	11.0 lb./in. <sup>2</sup>
<i>Rated voltage</i> ... ..	112 volts d.c.
<i>Maximum current consumption (under above conditions)</i> ... ..	3.3 amps
<i>Voltage limits</i> ... ..	100/116 volts d.c.
<i>Electrical connection (Plessey CZ.50356)</i> ... ..	Ref. No. 5X/6181
<i>No-flow delivery pressure (max.)</i> ... ..	Fig. 4
<i>New brush length (to centre of radius)</i> ... ..	11.8 mm. (0.465 in.)
<i>Minimum permissible brush length for re-fitting</i> ... ..	10.6 mm. (0.417 in.)
<i>Brush spring loading</i> ... ..	4.5 oz. at 6.7 - 9.5 mm. (0.264 - 0.374 in.) compressed length
<i>Minimum permissible commutator diameter for further use</i> ... ..	24.0 mm. (0.945 in.)
<i>Undercut commutator segments</i> ... ..	0.036 in. wide x 0.020 in. deep
<i>Maximum commutator eccentricity with shaft journals</i> ... ..	0.001 in. (total)

RESTRICTED

**LEADING PARTICULARS (continued)**

<i>Motor unit bearings</i>	...	...	...	...	<i>Hoffman 106 PP</i> <i>Hoffman 112 PP</i> <i>(pre-packed with XG/295 grease)</i>
<i>Pump unit bearings</i>	...	...	...	...	<i>Hoffman 112 PP</i> <i>(pre-packed with XG/295 grease)</i> <i>Plain carbon - fuel lubricated</i>
<i>Delivery outlet</i>	...	...	...	...	<i>1½ in. B.S.P.</i>
<i>Gland drain</i>	...	...	...	...	<i>Special (Vickers Design)</i>
<i>Weight of unit</i>	...	...	...	...	<i>15-25 lb.</i>

**Note...**

*Dismantling the above pumps to inspect or replace brushes or bearings will necessitate full re-testing of the unit in accordance with the approved Schedule of Acceptance Tests.*

**Introduction**

1. Type SPE.1207 fuel pumps are of the inclined sump mounting, right-angled drive type described in para. 23-25 of the basic chapter and suitable for 112 volts d.c. supply. Illustrations showing the main features of this type of pump will be found at the end of this appendix.

**Type differentiation**

2. Basic differences between the various marks of SPE.1207 pumps are as follows:-  
 SPE.1207 Mk.1 ... Basic design  
 SPE.1207 Mk.2 ... Generally as SPE.1207 Mk.1 but incorporating

a venting between the motor unit and gear box, and an improved thrower arrangement including a labyrinth seal and a fuel trap to contain the bellows seal leakage under negative "g" conditions. The clearance between the bellows seal body and the carbon seal is increased to avoid seizure hazard during high altitude operations.

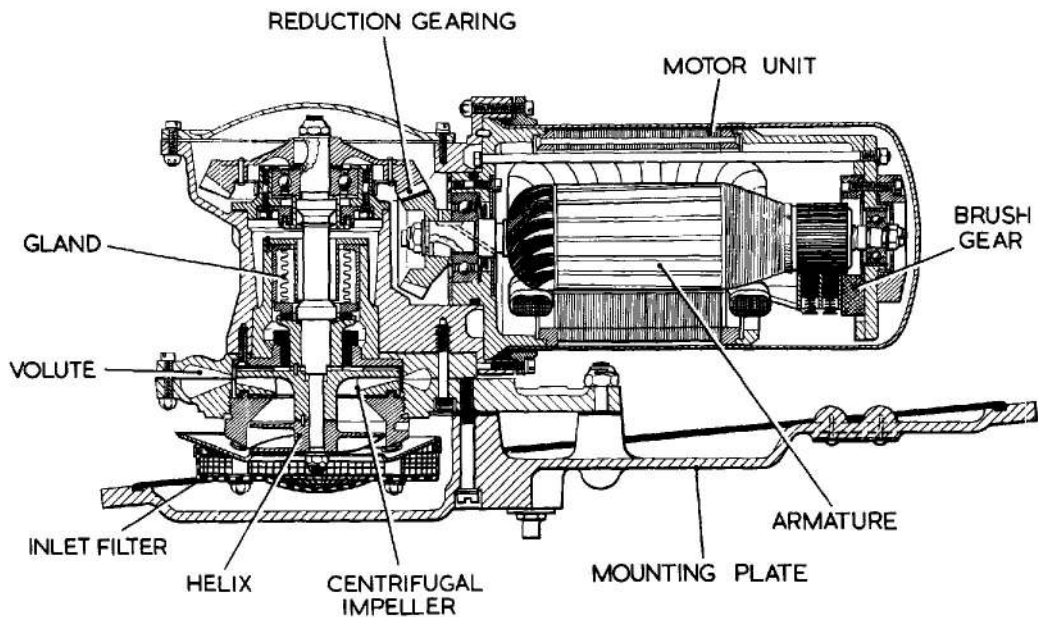

**Fig. 1 Sectional view of SPE.1207 Mk.2**

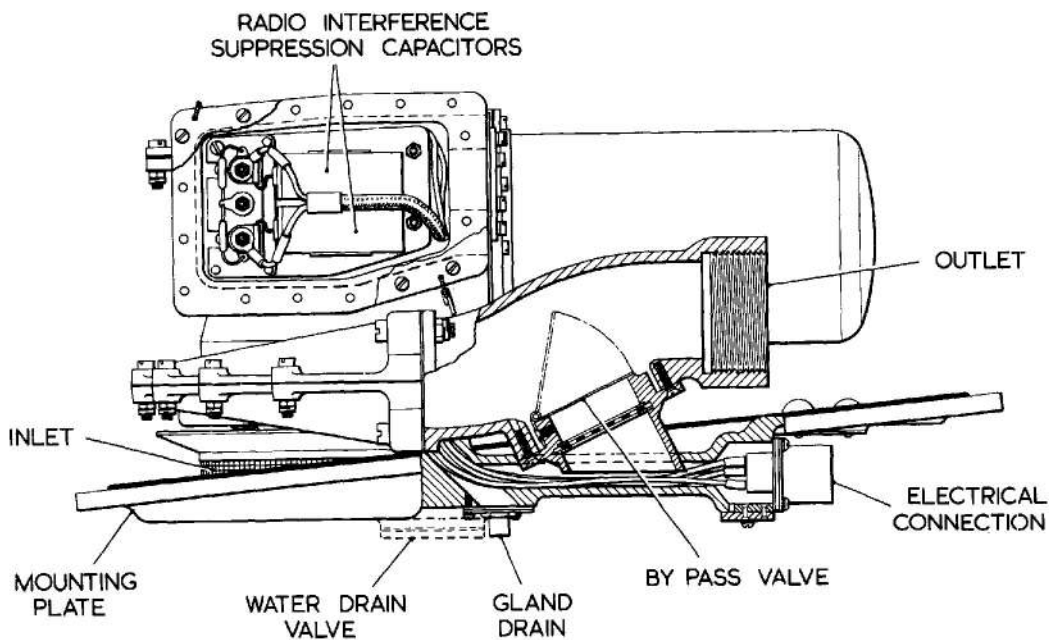

**Fig. 2 Sectional view of SPE.1207 Mk.2 outlet and by-pass assembly**

**RESTRICTED**

NOTE :- FOR NORMAL SPEED JOIN A TO B  
FOR LOW SPEED JOIN A TO D AND B TO C

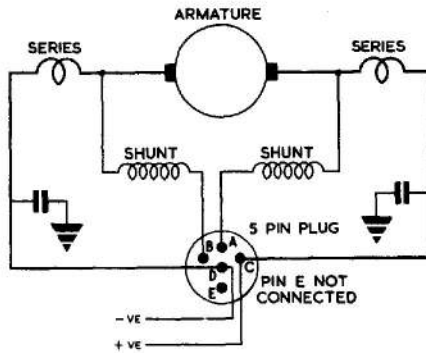

Fig. 3 Circuit diagram

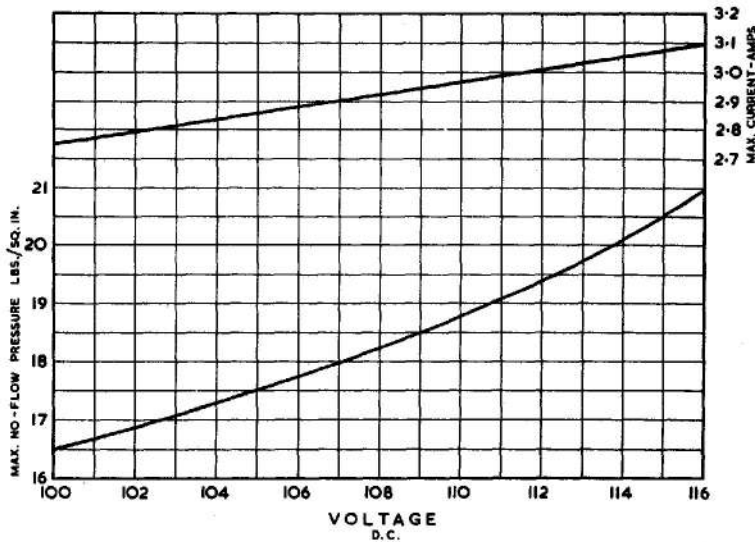

Fig. 4 Graph: Estimated current consumption and delivery pressure under no-flow conditions

Note...

The above graphs are provided as a guide to the pump performance under no-flow conditions and figures derived from them at voltages other than 116 volts d.c. are not to be interpreted as forming part of the approved Acceptance Test Specification of the pump.

RESTRICTED

## Appendix 3

## PUMPS, FUEL, SPE.1214 MK.1, 1A, 2 AND 3

## LIST OF CONTENTS

	Para.		Para.
Introduction ... ..	1	Type differentiation ... ..	2

## LIST OF ILLUSTRATIONS

	Fig.		Fig.
Sectional view of SPE.1214 Mk.3 ... ..	1	Graph: Estimated current consumption and delivery pressure under no-flow conditions ... ..	4
Sectional view of SPE.1214 Mk.3 by-pass ducting ... ..	2		
Circuit diagram ... ..	3		

## LEADING PARTICULARS

Pump, fuel, SPE.1214 Mk.1 ... ..	Ref. No. 5UE/6211
Pump, fuel, SPE.1214 Mk.1A ... ..	Ref. No. 5UE/
Pump, fuel, SPE.1214 Mk.2 ... ..	Ref. No. 5UE/
Pump, fuel, SPE.1214 Mk.3 ... ..	Ref. No. 5UE/6623
Motor unit ... ..	112 volts d.c.: flameproof: radio interference suppressed: suitable for two speed operations.
Rated output ... ..	1200 g.p.h.
Fuel delivery pressure (at rated voltage) ... ..	11.0 lb./in. <sup>2</sup>
Rated voltage ... ..	112 volts d.c.
Maximum current consumption (under above conditions) ... ..	3.3 amps.
Voltage limits ... ..	100/116 volts d.c.
Electrical connection (Plessey CZ.50356) ... ..	Ref. No. 5X/6181
No-flow delivery pressure (max.) ... ..	Fig. 4.
New brush length (to centre of radius) ... ..	11.8 mm. (0.465 in.)
Minimum permissible brush length for re-fitting ... ..	10.6 mm. (0.417 in.)
Brush spring loading ... ..	4.5 oz. at 6.7 - 9.5 mm. (0.264 - 0.374 in.) compressed length.
Minimum permissible commutator diameter for further use ... ..	24.0 mm. (0.945 in.)

RESTRICTED

## LEADING PARTICULARS (Continued)

Undercut commutator segments... ..	0-036 in. wide x 0-020 in. deep
Maximum commutator eccentricity with shaft journals ... ..	0-001 in. (total)
Motor unit bearings ... ..	Hoffman 106 PP Hoffman 112 PP (pre-packed with XG/295 grease)
Pump unit bearings.. ... ..	Hoffman 112 PP (pre-packed with XG/295 grease) Plain carbon - fuel lubricated
Delivery outlet ... ..	1½ in. B.S.P.
Gland drain ... ..	¼ in. B.S.P.
Weight of unit ... ..	16-5 lb. (Mk. 1) 16-8 lb. (others)

### Notes...

*Dismantling the above pumps to inspect or replace brushes or bearings, will necessitate full re-testing of the unit in accordance with the approved Schedule of Acceptance Tests.*

### Introduction

1. Type SPE.1214 fuel pumps are of the side-mounting, right-angled drive type described in para. 13-16 of the basic chapter. They are designed for use on 112 volts d.c. supply and are used in installation positions where it is required to pressure re-fuel the tank through the pump. The by-pass valve opens against a positive seating and prevents fuel passage back through the pump impeller system. Illustrations showing the main features of this type of pump will be found at the end of this appendix.

### Type differentiation

2. Basic differences between the various marks of SPE.1214 pumps are as follows:-

SPE.1214 Mk.1 ... Basic design  
SPE.1214 Mk.1A ... Generally as SPE.1214 Mk.1 but fitted with revised electrical supply lead and gland drain conduits.

SPE.1214 Mk.2 ... Generally as SPE.1214 Mk.1 but the electrical supply lead and gland drain conduits are re-designed to reduce overall the width of the pump and ease assembly into aircraft tank.

SPE.1214 Mk.3 ... Generally as SPE.1214 Mk.2 but incorporating venting between the motor unit and gear box, an improved thrower arrangement including a labyrinth seal and a fuel trap to contain the bellows seal leakage under negative "g" conditions. Clearance between the bellows seal body and the carbon seal increased to avoid seizure hazard during high altitude operations.

**RESTRICTED**

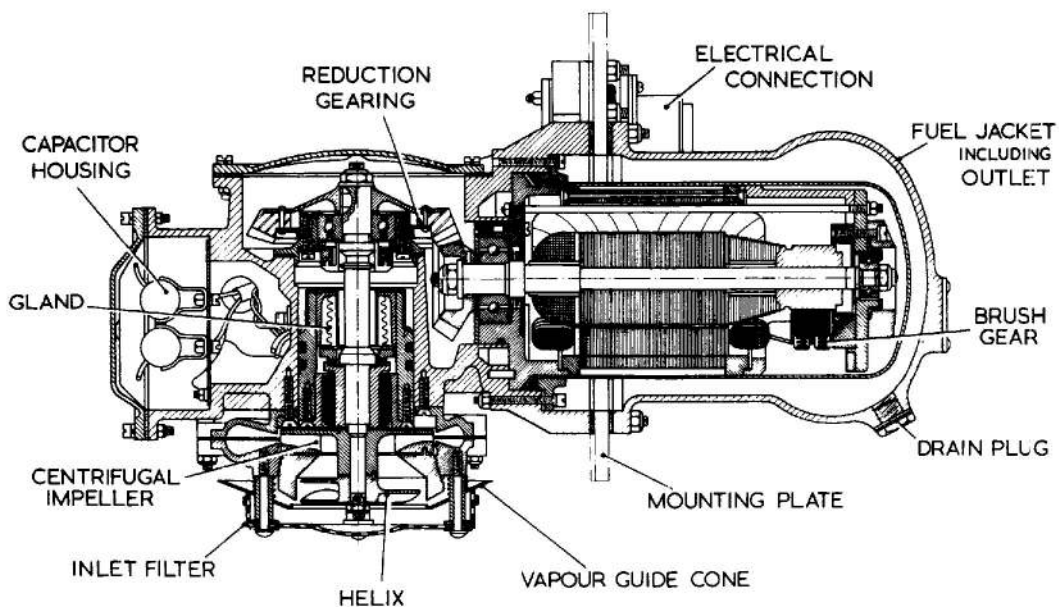

**Fig. 1 Sectional view of SPE.1214 Mk.3**

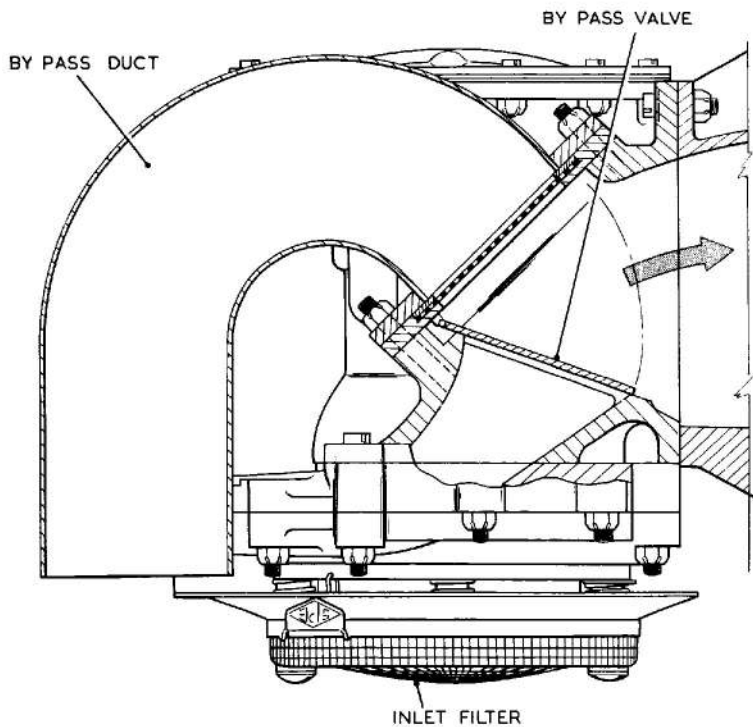

**Fig. 2 Sectional view of SPE.1214 Mk.3 by-pass ducting**

**RESTRICTED**

NOTE -- FOR NORMAL SPEED JOIN A TO B  
FOR LOW SPEED JOIN A TO D AND B TO C

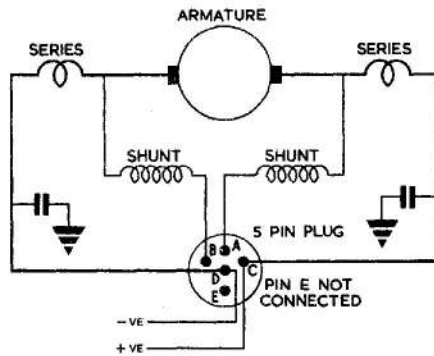

Fig. 3 Circuit diagram

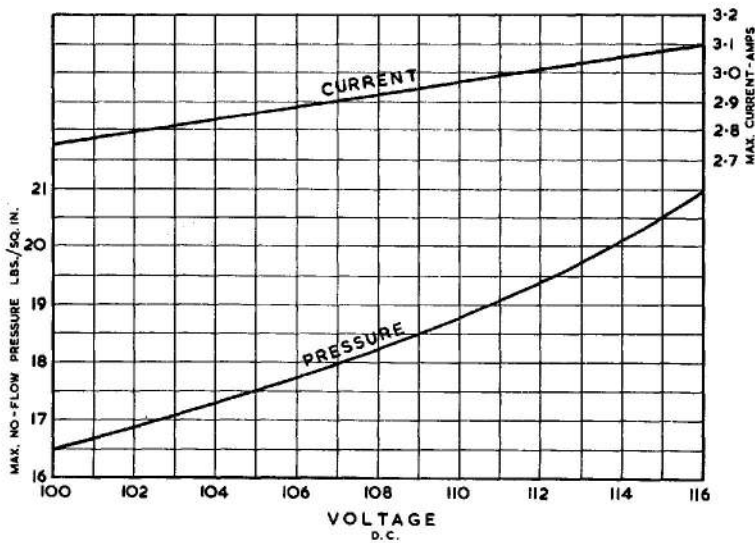

Fig. 4 Graph: Estimated current consumption and delivery pressure under no-flow conditions

The above graphs are provided as a guide to the pump performance under no-flow conditions and figures derived from them at voltages other than 116 volts d.c. are not to be interpreted as forming part of the approved Acceptance Test Specification for the pump.

**RESTRICTED**

## Appendix 4

### PUMPS, FUEL, SPE.1215

#### LIST OF ILLUSTRATIONS

	<i>Fig.</i>
Sectional view of SPE.1215, Mk. 2 ...	1
Sectional view through SPE.1215, Mk. 2 by-pass valve ... ..	2
Circuit diagram ... ..	3
'No fuel flow' electrical test graph ...	4

#### LEADING PARTICULARS

Pump fuel, SPE.1215 Mk.1 ... ..		Ref. No. 5UE/6212
Pump fuel, SPE.1215 Mk.1A ... ..		Ref. No. 5UE/6626
Pump fuel, SPE.1215 Mk.2 ... ..		Ref. No. 5UE/6624
Pump fuel, SPE.1215 Mk.3 ... ..		Ref. No. 5UE/7424
Voltage limits ... ..		100/116V d.c.
Rated voltage ... ..		112V d.c.
Rated output at 112V. d.c. ... ..		1200 gall./hr.
Minimum delivery pressure at rated output/voltage ... ..		11.0 lb./in. <sup>2</sup>
Max. current consumption at rated output/voltage ... ..		3.3A
Max. 'no-flow' delivery pressure at 116V. d.c. ... ..		21.0 lb./in. <sup>2</sup>
Minimum 'no-flow' delivery pressure ... ..		See Fig. 4
Electrical connection ... ..	Special plug and socket: 2—7 amp, and 2—19 amp pins	
Delivery outlet tapping ... ..		1½ in. B.S.P.
Gland drain tapping ... ..		½ in. B.S.P.
Weight of unit ... ..		13.0 lb. (approx.)

**RESTRICTED**

## Introduction

1. Type SPE.1215 fuel pumps are of the base flush mounting, right-angled drive type described in para. 17-19 of the basic chapter. They are designed for use on 112V d.c. supply and are used in installation positions where it is required to pressure re-fuel the tank through the pump unit. The by-pass valve is held closed by a spring and prevents fuel passage back through the impeller system. Illustrations showing the main features of this type of pump will be found at the end of this appendix.

## Type differentiation

2. Basic differences between the various marks of SPE.1215 pumps are as follows :—

### SPE.1215 Mk. 1

Initial production design.

### SPE.1215 Mk. 1A

Generally similar to the SPE.1215 Mk. 1 pump but incorporating a redesigned electrical connection with new shells and union nuts.

### SPE.1215 Mk. 2

Generally as SPE.1215 Mk. 1A but incorporating a venting between the motor unit and the gear box, an improved thrower arrangement incorporating a labyrinth seal and a fuel trap to contain any bellows gland leakage under negative 'g' conditions. The clearance between the bellows seal body and the carbon seal is increased to avoid seizure hazard under high altitude operating conditions.

### SPE.1215 Mk. 3

Generally similar to SPE.1215 Mk. 2 but the suppression unit chamber and gear box covers redesigned to include integrally bonded rubber gaskets to improve sealing.

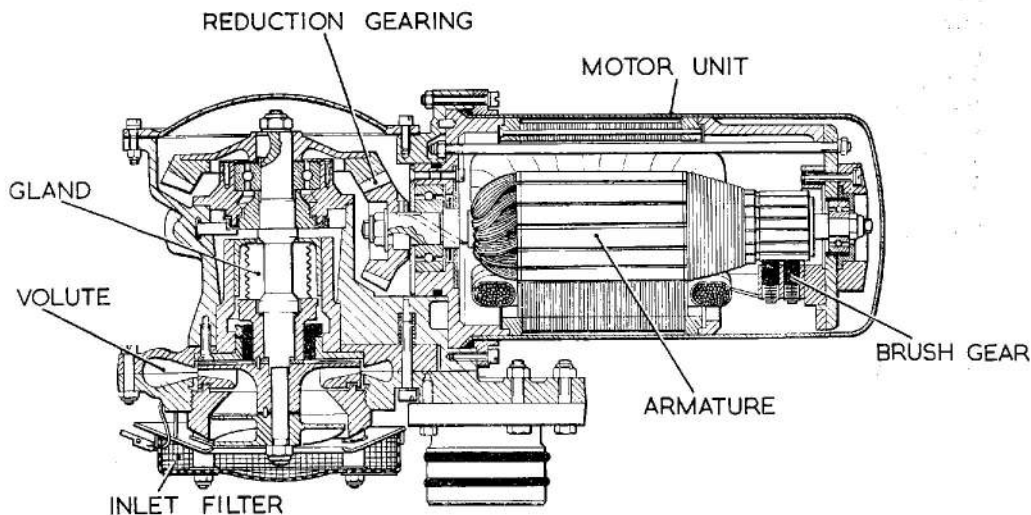

Fig. 1. Sectional view of SPE.1215 Mk. 2

RESTRICTED

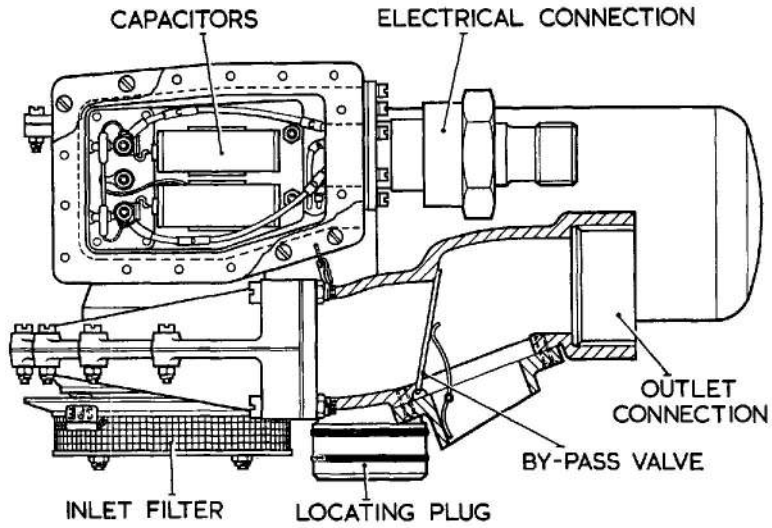

Fig. 2. Sectional view through SPE.1215, Mk. 2 by-pass valve

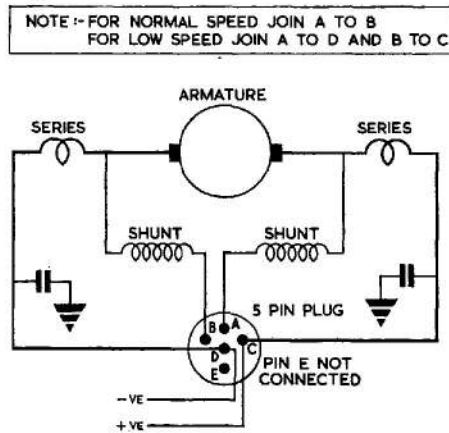

Fig. 3. Circuit diagram

**RESTRICTED**

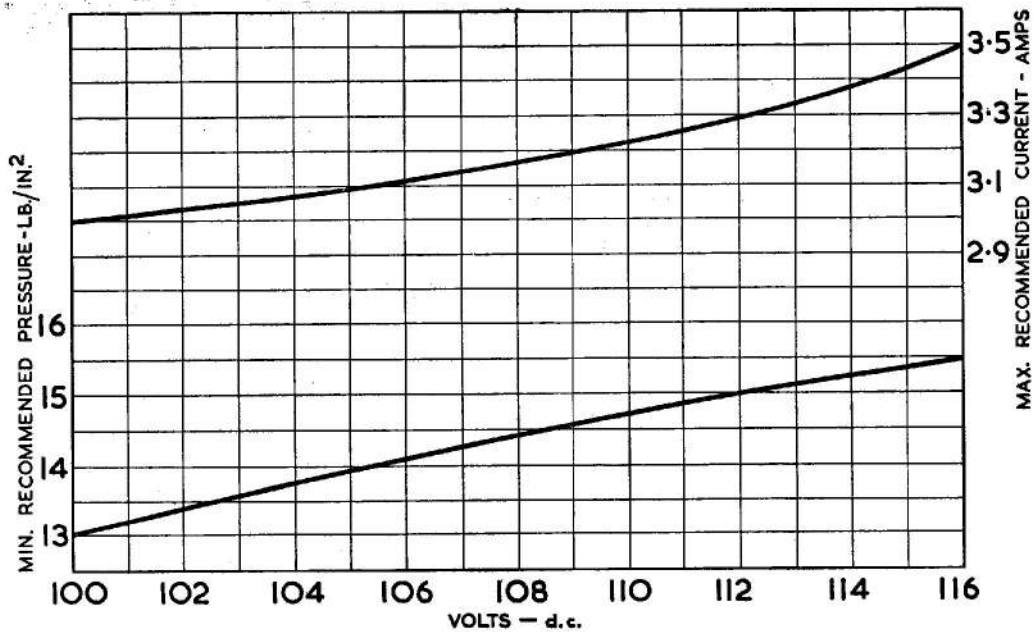

Fig. 4. "No. fuel flow" electrical test graph

Note . . .

*The graph (Fig. 4) is provided as a guide to pump performance under 'no-flow' conditions: the figures derived from it are not to be interpreted as forming a part of the approved Acceptance Test Specification for the pump.*

**RESTRICTED**

## Appendix 5

### PUMPS, FUEL, SPE.1216

#### LIST OF ILLUSTRATIONS

	<i>Fig.</i>
<i>Sectional view of SPE.1216, Mk. 2 ...</i>	1
<i>Sectional view through SPE.1216, Mk. 2 by-pass valve ... ..</i>	2
<i>Circuit diagram ... ..</i>	3
<i>'No fuel flow' electrical test graph ...</i>	4

#### LEADING PARTICULARS

<b>Pump, fuel, Type SPE.1216 Mk. 1</b> ... ..	<b>Ref. No. 5UE/6213</b>
<b>Pump, fuel, Type SPE.1216 Mk. 2</b> ... ..	<b>Ref. No. 5UE/6625</b>
<b>Pump, fuel, Type SPE.1216 Mk. 3</b> ... ..	<b>Ref. No. 5UE/7425</b>
<i>Voltage limits</i> ... ..	100/116V d.c.
<i>Rated voltage</i> ... ..	112V d.c.
<i>Rated output at 112V. d.c.</i> ... ..	1200 gall./hr.
<i>Delivery pressure at rated output/voltage</i> ... ..	11.0 lb./in. <sup>2</sup> min.
<i>Max. current consumption at rated output/voltage</i> ... ..	3.3A
<i>Max. 'no-flow' delivery pressure at 116V. d.c.</i> ... ..	21.0 lb./in. <sup>2</sup>
<i>Minimum 'no-flow' delivery pressure</i> ... ..	See Fig. 4
<i>Electrical connection (Plessey 2CZ.111401)</i> ... ..	Ref. No. 5X/7142
<i>Delivery outlet</i> ... ..	Stud ring on mounting plate
<i>Gland drain tapping</i> ... ..	$\frac{1}{4}$ in. B.S.P.
<i>Weight of unit</i> ... ..	15.25 lb.

**RESTRICTED**

## Introduction

1. The type SPE.1216 fuel pumps are of the base sump mounting, right-angled drive type described in para. 20-22 of the basic chapter. They are suitable for use on a 112V d.c. supply and are used in installation positions where it is required to pressure refuel the tank through the pump unit. The by-pass valve closes against a positive seating during the refuelling operation and prevents fuel passage back through the pump impeller system. Illustrations showing the main features of this type of pump will be found at the end of this appendix.

## Type differentiation

2. Basic differences between the various marks of SPE.1216 pumps are as follows:—

### SPE.1216 Mk. 1

Initial production design.

### SPE.1216 Mk. 2

Generally as SPE.1216 Mk. 1 but incorporating a venting between the motor unit and the gear box and an improved thrower arrangement incorporating a labyrinth seal and a fuel trap to contain the bellows seal leakage under negative 'g' conditions. Clearance between the bellows seal body and the carbon seal is increased to avoid seizure hazard under high altitude operating conditions.

### SPE.1216 Mk. 3

Generally similar to SPE.1216 Mk. 2 pump but the suppression chamber and gear box covers redesigned to include integrally bonded rubber gaskets to improve sealing.

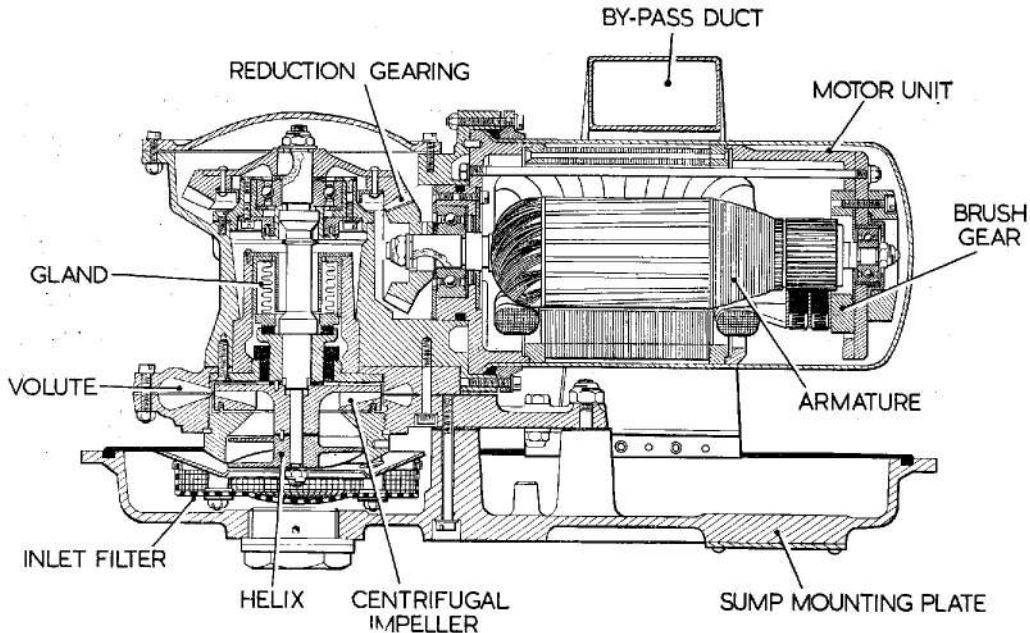

Fig. 1. Sectional view of SPE.1216, Mk. 2

RESTRICTED

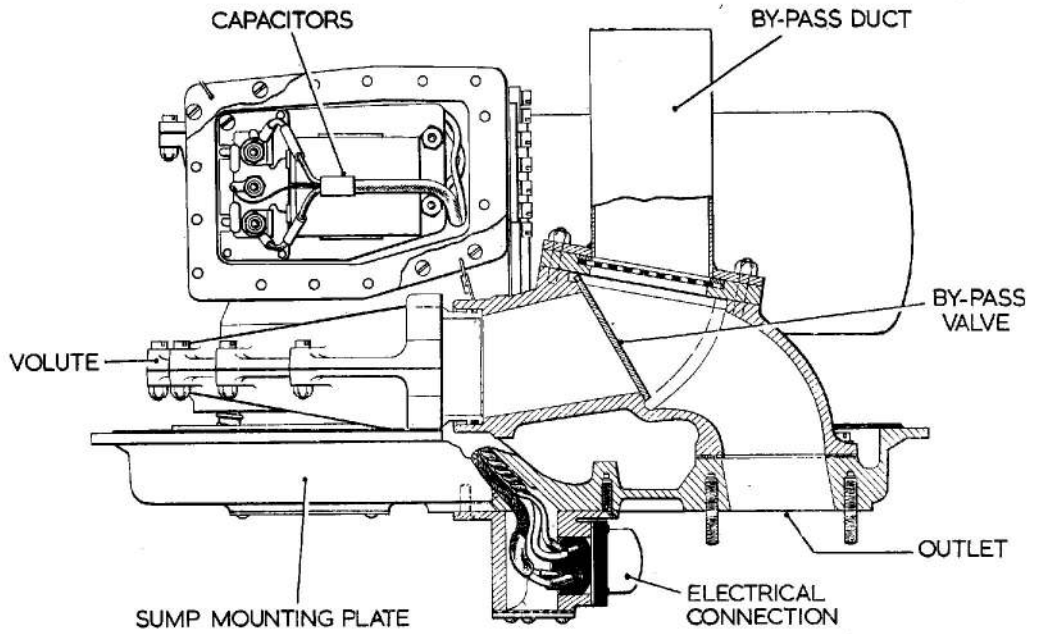

Fig. 2. Sectional view through SPE.1216, Mk. 2 by-pass valve

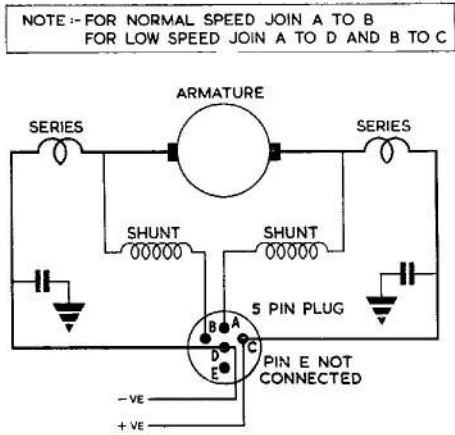

Fig. 3. Circuit diagram

**RESTRICTED**

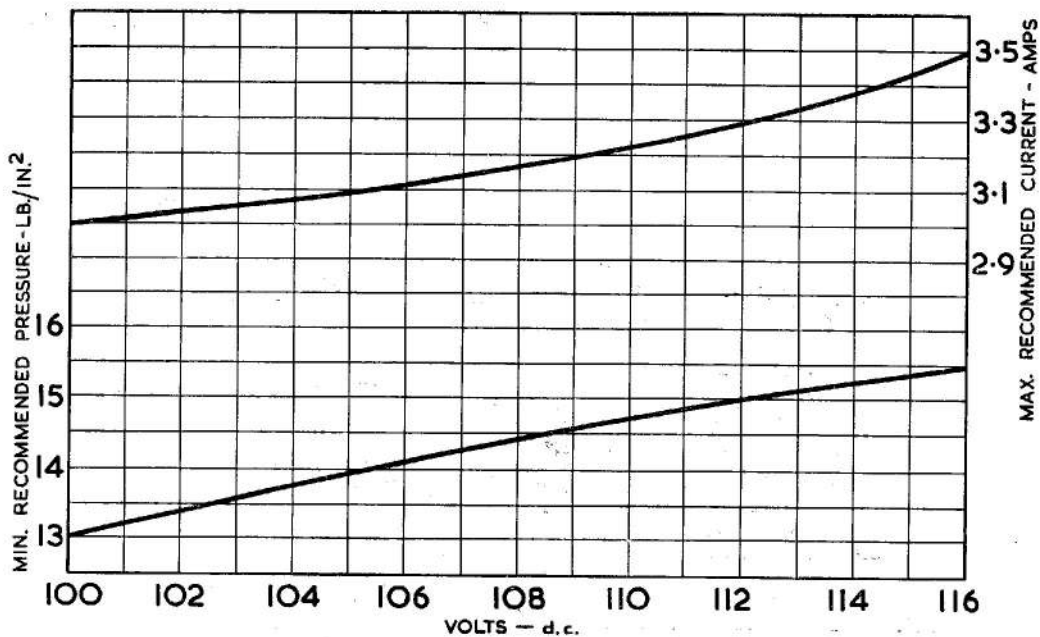

Fig. 4. "No fuel flow" electrical test graph

**Note . . .**

*The graph (Fig. 4) is provided as a guide to pump performance under 'no-flow' conditions: the figures derived from it are not to be interpreted as forming a part of the approved Acceptance Test Specification for the pump.*

**RESTRICTED**

This file was downloaded from the RTFM Library.  
Link: [www.scottbouch.com/rtfm](http://www.scottbouch.com/rtfm)

Please see site for usage terms, and more aircraft documents.

