

## Chapter 7

## PUMP, FUEL, TYPE B.P.8.

## LIST OF CONTENTS

	<i>Para.</i>		<i>Para.</i>
<i>Introduction</i> ... ..	1	<i>Removal</i> ... ..	13
<b>Description</b>		<i>Pre-installation checks</i> ... ..	15
<i>General</i> ... ..	2	<i>Installation</i> ... ..	16
<i>Motor unit</i> ... ..	3	<b>Servicing</b>	
<i>Upper base assembly</i> ... ..	6	<i>Routine inspection</i> ... ..	18
<i>Lower base assembly</i> ... ..	8	<i>Electrical test</i> ... ..	20
<i>Filter</i> ... ..	9	<i>Operational test</i> ... ..	24
<b>Operation</b> ... ..	10	<i>Gland leakage</i> ... ..	25
<b>Removal and installation</b>		<i>Insulation resistance test</i> ... ..	26

## LIST OF TABLES

	<i>Table</i>
<i>Faults, possible causes and rectification</i> ... ..	1

## LIST OF ILLUSTRATIONS

	<i>Fig.</i>		<i>Fig.</i>
<i>External view of typical B.P.8 fuel pump</i> ... ..	1	<i>Circuit diagram</i> ... ..	3
<i>Sectional view of B.P.8, Mk. 4 fuel pump</i> ... ..	2	<i>'No fuel flow' electrical test graph</i> ... ..	4

## LIST OF APPENDICES

	<i>App.</i>
<i>Pump, fuel, Type B.P.8 Mk. 1, 3 and 4</i>	1

RESTRICTED

## Introduction

1. Type B.P.8 fuel booster pumps are electrically driven, self-contained units designed to supply fuel under pressure to the aircraft engine driven fuel pumps or alternatively to transfer fuel from auxiliary to main tanks. Rated operating voltage is 112V d.c. and radio interference noise suppressors are included in the internal electrical circuit of the pump. Details of the differences between the mark numbers of each type, together with the Leading Particulars, are given in the appendices to this chapter.

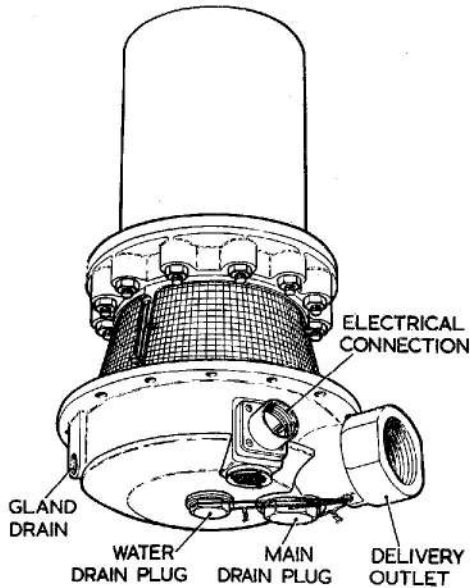

Fig. 1. External view of typical B.P.8 fuel pump

## DESCRIPTION

### General

2. A typical B.P.8 fuel pump is illustrated in Fig. 2. This basic arrangement is common to all marks of the pump, but the installation of the main gland preventing fuel ingress into the motor unit varies according to the mark number of the pump. Details are given in appendices to this chapter.

3. The basic pump design comprises three main sub-assemblies:—

- (1) The driving motor unit, with casing.
- (2) The upper base assembly.
- (3) The lower base assembly.

### Motor unit

4. The motor unit is a totally enclosed, two pole compound wound machine suitable for use on a supply voltage of 100/116V d.c. Brush gear is of unit construction to facilitate assembly, comprising four brushes, two on each side in pairs producing two brush tracks. The armature shaft is supported by two ball-bearings, both of which are pre-packed during manufacture with a high melting/low freezing point grease and cannot be re-lubricated. The upper bearing is retained in a steel sleeve, and the inner race of the lower bearing is locked to the armature shaft by a screwed ring which incorporates a "thrower" to fling off any fuel which may have seeped past the main gland. The design of thrower nut varies according to the mark of pump examined (refer to appendices).

5. Radio interference noise suppressors are mounted to the upper end of the motor casing. The complete motor unit spigots into a recess in the pump upper base casting and is enclosed in a light alloy casing which when bolted into position compresses a synthetic rubber joint ring to form a fuel tight assembly.

### Upper base assembly

6. The upper base assembly is in the form of two circular ends separated by two cored pillars. The upper end of the casting is recessed to locate the motor, and encloses a bellows gland, seal and thrower ring, which prevent fuel ingress into the motor. The gland and seal arrangement varies for different marks of pumps; on Mk. 3 and subsequent marks of pumps, the seal is arranged on the motor side of the pump gland. The cored pillars are utilized for:—

- (1) A combined motor vent and conduit for the electrical supply leads, fitted between the pump socket and the motor brush gear.
- (2) A drain duct for removing any fuel which may seep past the bellows gland and seal.

7. The armature shaft of the motor unit extends through the main gland and carries the combined helico/centrifugal impeller. A vapour guide cone is fitted around the fuel inlet to the impeller system to divert air vapour, which may be evolved under

RESTRICTED

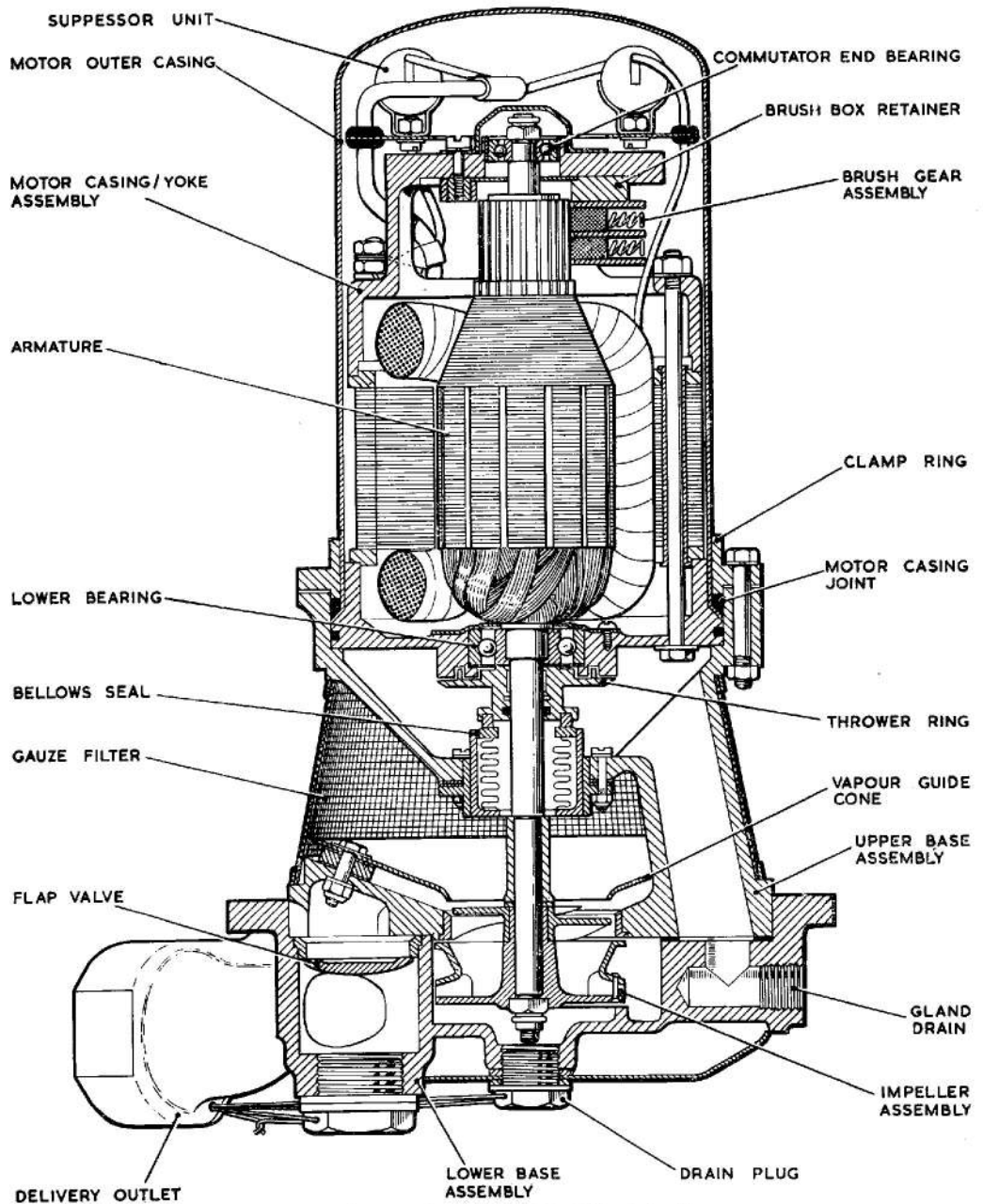

Fig. 2. Sectional view of B.P.8, Mk. 4 fuel pump

RESTRICTED

operating conditions, out of the main fuel stream through the pump.

#### Lower base assembly

8. The lower base casting includes a circular flange with fourteen 2-B.A. clearance holes for attachment of the pump assembly to the tank stud ring. It also carries the  $\frac{1}{4}$  in. B.S.P. fuel delivery outlet, a  $\frac{1}{4}$  in. B.S.P. tapping for the gland drain connection and a mounting for the electrical supply socket, all of which are outside the tank when the pump unit is installed. A perforated fireproof cover fits over the motor breather aperture and a  $\frac{3}{4}$  in. B.S.P. plug is provided in the base of the delivery outlet to blank off the pressure fuel drain connection. A by-pass flap valve is fitted at the delivery end of the integral cast volute, in the base casting, to enable fuel to be drawn directly from the tank by the engine driven fuel pump when the booster pump is idle. This valve is normally held closed by booster pump pressure.

#### Filter

9. A truncated conical mesh filter completely surrounds the fuel entry and prevents the ingress of foreign matter into the impeller system and fuel delivery line.

### OPERATION

10. When the pump motor is energised, fuel from the tank is drawn into the eye of the helico-centrifugal impeller and then forced through the spiral volute in the pump base casting to the fuel outlet connection and to the delivery line.

11. Under conditions in which the flow from the pump is low due to the reduced engine requirements, the impellers continue to rotate at approximately normal speed without causing any excessive increase in fuel delivery pressure.

12. When the pump is idle, the delivery pressure on the underside of the by-pass valve is relieved, allowing the valve to open and enabling the engine driven pump to draw fuel direct from the tank without passing through the impeller system of the pump.

### REMOVAL AND INSTALLATION

#### Removal

13. Before attempting to remove a pump, ensure that the tank has been drained of fuel and that the electrical supply to the pump unit has been switched off. The former can be checked by easing the drain plug in the delivery outlet arm of the lower base casting, when, if there is any fuel remaining in the tank, it will have a free flow through the by-pass valve and volute passages of the pump to the drain plug.

14. The precise method of removing a B.P.8 fuel pump is detailed in the appropriate Aircraft Handbook. In general terms it will consist of disconnecting the fuel delivery and gland drain pipes, and disconnecting the supply at the electrical connection socket. The pump can be removed by releasing the fourteen nuts securing it to the tank stud ring. Support the weight of the pump during this operation. Two  $\frac{1}{4}$  in B.S.F. screws can be used, if necessary, in the lower base casting tapped flange holes to assist in breaking the joint with the tank mounting ring.

#### Pre-installation checks

15. The installation of any new pump should be preceded by the following checks:

(1) Ensure that the pump has not been stored for longer than the specified maximum period (i.e. 12 months in the original packing and carton as supplied by the pump manufacturer, or 3 years where special packing has been provided). Pumps stored for periods in excess of these maxima must not be used without being dismantled, examined and tested as detailed in the relevant chapter in Vol. 6.

(2) Inspect the exterior of the pump for evidence of damage, security of locking wires, general cleanliness and corrosion. Blend out slight areas of corrosion and apply an approved protective finish (Chromic acid solution) to the unprotected area.

(3) Check that transit plugs have been removed from the delivery outlet, the gland drain tapping in the base casting and from the electrical con-

**RESTRICTED**

nection socket. Remove any tape or other protective material from the inlet filter and motor breather gauzes.

(4) It is advisable to make a starting check on the pump before installation. Apply a 112V d.c. electrical supply through the electrical connection. The pump must start immediately. Repeat the test several times. If the pump fails to start immediately, it must be returned to an overhaul base for further testing using approved equipment.

### Installation

16. The above pre-installation checks apply to all aircraft installations of these pumps. For detailed procedure covering installation in a particular aircraft, reference should be made to the relevant Aircraft Handbook.

17. As a general example, installation in the aircraft will comprise the following operations :

- (1) Fitting a new joint washer between the pump mounting flange and the tank stud ring, using an approved jointing compound on both sides of the washer.
- (2) Securing the pump to the tank stud ring with fourteen 2-B.A. nuts and lockwashers.
- (3) Reconnecting the fuel delivery and gland drain pipes, ensuring when relevant that the open end of the latter faces towards the rear of the aircraft to prevent possible pressurisation in flight.
- (4) Reconnecting the electrical supply to the pump socket.
- (5) Wire-locking all pipe connections, union nuts, etc.

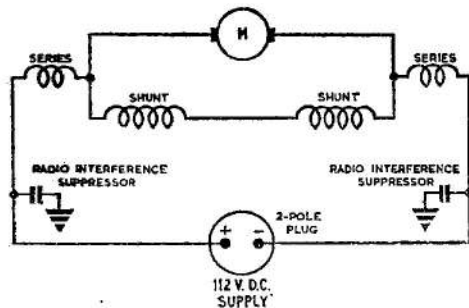

Fig. 3. Circuit diagram

## SERVICING

### Routine inspection

18. At routine inspections the following procedure applies :

- (1) Inspect all the pipe connections and wire-locking to the pump. Check that the joint between the fuel pump and the tank mounting ring is dry. Correct as necessary.
- (2) Test the pump as detailed in para. 20-26. If the pump performance is found to be unsatisfactory in any way, the pump must be removed from the aircraft and a new or reconditioned unit fitted. No in-situ maintenance is possible.
- (3) Ensure that the by-pass valve is functioning correctly by completing relevant tests detailed in the appropriate Aircraft Handbook.
- (4) Ease the central plug in the pump base casting and collect a small quantity of liquid from the tank in a suitable vessel. Examine for water/fuel separation. If the presence of water in the fuel is suspected, drain off a further quantity until there is no further separation of the two liquids.

19. At the periods laid down in the appropriate Servicing Schedules, all pumps are to be replaced by new or reconditioned units drawn from Stores. Faulty and time expired pumps must be returned to a Maintenance Unit or to the manufacturer for repair.

### Electrical test

20. A routine electrical test in accordance with the appropriate Servicing Schedule should be made to ascertain that the motor unit is functioning satisfactorily. These tests must be made with the motor unit on load—i.e. immersed in and pumping fuel. The pump must be replaced by a new or reconditioned unit if there is any evidence of erratic performance such as an excessive current consumption.

'No fuel flow' electrical test

Note . . .

The following 'no fuel flow' electrical test is only applicable to aircraft with the

**RESTRICTED**

necessary instrumentation. Where no test panel is provided, particular attention must be paid to the Electrical test (para. 20) and to the Operational test (para. 24).

21. Ascertain the position of the aircraft pump test socket and switches by reference to the relevant Aircraft Handbook. Proceed as follows :

- (1) Close all fuel cocks between the pump and engine pump to ensure that no fuel can flow.
- (2) Connect a suitable portable ammeter to the socket on the test panel.

**Note . . .**

*When using a clip-on type ammeter, the tongs should be opened and closed smartly prior to use to reduce the hysteresis errors.*

- (3) Switch on the pump by depressing the switch on the test panel. Observe the ammeter reading for a period of not less than 30 seconds.

22. Interpret the readings obtained as follows :

- (1) A steady reading not exceeding that indicated by the graph (Fig. 4) for the measured applied voltage, indicates that the motor unit is functioning satisfactorily.

**Note . . .**

*The graph (fig. 4) is provided as a guide only to the pump performance under 'no flow' conditions: the figures derived from it are not to be interpreted as forming a part of the approved Acceptance Test Specification for the pump.*

- (2) Current consumption in excess of the graph reading indicates either a faulty motor unit, a rise in torque loading due to the obstruction of moving parts, or a restriction of the fuel flow.
- (3) A fluctuating reading indicates faulty contacts, defective brushes, faulty commutation or that bearings or other rotating parts are binding.
- (4) A zero reading indicates an open circuit and is consistent with a blown fuse, defective switch, faulty wiring or in extreme cases complete motor failure.

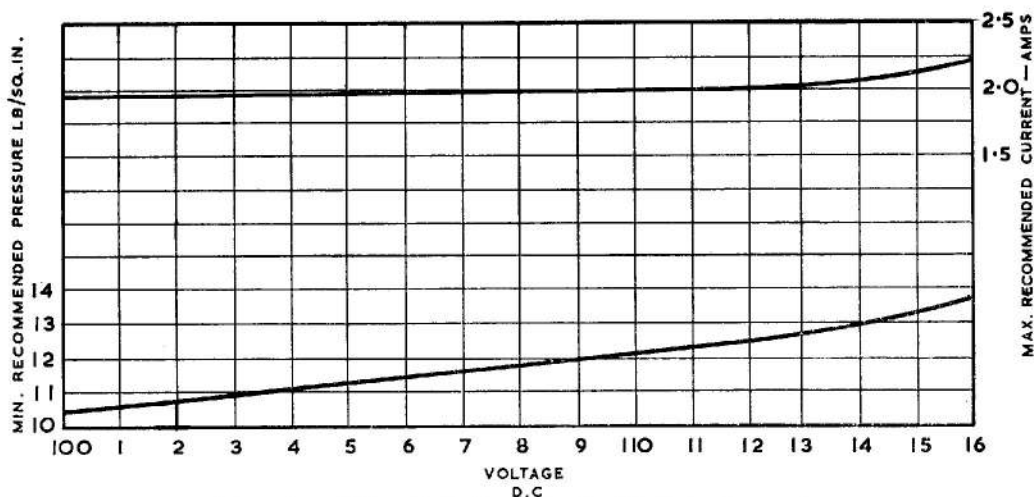

Fig. 4. "No fuel flow" electrical test graph

**RESTRICTED**

23. When the above tests have been completed, release the test switch and disconnect the ammeter.

#### Operational test

24. Subject to the electrical test being completed satisfactorily, the pump should be tested where possible for proof of performance and checked against the performance figures quoted in the appropriate appendix to this chapter. Refer to the relevant Aircraft Handbook for performance details. Possible causes of failure to obtain the required performance are detailed in Table 1.

#### Gland leakage

25. During the above tests an examination should be made of the gland drain exit pipe

for fuel leakage. The leakage must not exceed two drops per minute while the pump is running, or one drop per minute while stationary. Any leakage in excess of these figures will necessitate removal of the pump from the aircraft.

#### Insulation resistance test

26. Using a 500V d.c. controlled voltage insulation resistance tester, measure the insulation resistance between the socket pins and earth. When a new pump is drawn from Stores, the insulation resistance must not be less than 2 megohms. After installation, due to the humidity conditions prevalent in aircraft at dispersal points, the insulation resistance must be not less than 50,000 ohms.

**TABLE 1**  
**Faults, possible causes and rectification**

Fault	Possible cause	Rectification
Gland leakage	(1) Bad finish between gland seal faces. (2) Insufficient pressure between gland seal faces.	All these conditions require that the pump is removed from the aircraft and returned to a Maintenance Unit or to the pump manufacturer for repair.
Excessive current consumption	(1) Excessive loading on the metallic bellows gland. (2) Faulty motor unit. (3) Fouling of impeller system by foreign matter.	
Low delivery pressure Pressure surges	(1) Faulty motor unit. (1) Tight or pre-loaded bearings. (2) Excessive loading on the metallic bellows gland.	
Low insulation resistance	Dampness in motor windings.	

**RESTRICTED**



## Appendix 1

### PUMPS, FUEL, TYPE B.P.8 MK. 1, 3 and 4

Pump, fuel, Type B.P.8 Mk. 1	...	...	...	...	Ref. No. 5UE/6215
Pump, fuel, Type B.P.8 Mk. 3	...	...	...	...	Ref. No. 5UE/6621
Pump, fuel, Type B.P.8 Mk. 4	...	...	...	...	Ref. No. 5UE/6621
Voltage limits	...	...	...	...	100/116V d.c.
Rated voltage	...	...	...	...	112V d.c.
Rated output at 112V d.c.	...	...	...	...	400 gall./hr.
Minimum delivery pressure at rated output/voltage	...	...	...	...	10.0 lb./in. <sup>2</sup> —(Mk. 1) 10.5 lb./in. <sup>2</sup> —(Mk. 3 and 4)
Max. current consumption at rated output/voltage	...	...	...	...	2.0A (all marks)
Maximum 'no flow' delivery pressure at 112V d.c.	...	...	...	...	16 lb./in. <sup>2</sup>
Minimum 'no flow' delivery pressure	...	...	...	...	See Fig. 4, basic chapter.
Electrical connection (Plessey 2CZ.111402)	...	...	...	...	Ref. No. 5X/7143
Delivery outlet tapping	...	...	...	...	1½ in. B.S.P.
Gland drain tapping	...	...	...	...	¼ in. B.S.P.
Weight of unit	...	...	...	...	12-125 lb.

#### Type differentiation

1. Basic differences between the various marks of B.P.8 fuel booster pumps covered by this appendix are as follows:

- B.P.8 Mk. 1 Initial production design.
- B.P.8 Mk. 2 No pumps of this mark were manufactured.
- B.P.8 Mk. 3 Generally similar to B.P.8 Mk. 1 pump but includes a rubber seal between the

upper base and the motor unit at the cable inlet and a redesigned thrower assembly to prevent fuel ingress into the motor unit. Motor unit bearings are also of improved type.

- B.P.8 Mk. 4 Generally similar to B.P.8 Mk. 3 but fitted with new type of capacitors in radio noise suppression network.



This file was downloaded  
from the RTFM Library.

Link: [www.scottbouch.com/rtfm](http://www.scottbouch.com/rtfm)

Please see site for usage terms,  
and more aircraft documents.

