

## Chapter 8

### PUMP, FUEL, SPE.404

#### LIST OF CONTENTS

	<i>Para.</i>		<i>Para.</i>
<i>Introduction</i> ... ..	1	<b>Removal and installation</b> ... ..	15
<b>Description</b>		<i>Pre-installation checks</i> ... ..	17
<i>General</i> ... ..	2	<i>Installation</i> ... ..	18
<i>Motor unit</i> ... ..	3	<b>Servicing</b>	
<i>Pump unit</i> ... ..	4	<i>Routine inspection</i> ... ..	20
<i>Filters</i> ... ..	9	<i>Electrical test</i> ... ..	22
<i>By-pass valve</i> ... ..	10	<i>'No fuel flow' test</i> ... ..	23
<i>Radio interference noise suppressors</i>	11	<i>Operational test</i> ... ..	26
<b>Operation</b> ... ..	12	<i>Gland leakage</i> ... ..	27
		<i>Insulation resistance test</i> ... ..	28

#### LIST OF TABLES

	<i>Table</i>
<i>Faults, possible causes and rectification</i> ... ..	1

#### LIST OF ILLUSTRATIONS

	<i>Fig.</i>		<i>Fig.</i>
<i>External view of typical SPE.404 fuel booster pump</i> ... ..	1	<i>Sectional view of by-pass valve</i> ... ..	3
<i>Sectional view of typical SPE.404 fuel booster pump</i> ... ..	2	<i>Circuit diagram</i> ... ..	4
		<i>'No fuel flow' electrical test graph</i> ... ..	5

#### LIST OF APPENDICES

	<i>App.</i>
<i>Pumps, fuel, SPE.404 Mk. 1D, 1E, 1F and 1G</i> ... ..	1

RESTRICTED

## Introduction

1. Type SPE.404 series fuel pumps are electrically driven and designed to supply fuel under pressure to the aircraft main fuel supply line at the varying conditions of fuel de-aeration, vapour formation at high altitude, and high and low fuel temperatures. A horizontally mounted motor unit drives a vertical pump shaft through right angle reduction gearing. The pumps are fitted with built-in radio interference noise suppression capacitors. A suction by-pass valve is fitted to the delivery outlet, on each pump, and enables fuel to be withdrawn from the tank by the engine driven fuel pump when the booster pump is idle. The unit is mounted in the side of the tank by means of a special mounting plate to which the pump is secured. Rated operating voltage is 112V d.c. Details of the differences between the mark numbers of SPE.404 pumps together with the Leading Particulars are given in the appendices to this Chapter.

is mounted at right-angles to the pump shaft. The drive is effected through a bevel pinion, on the extended armature spindle, engaging with the bevel gear on the pump shaft, giving a speed reduction of 1.4 to 1.

4. The motor assembly, spigots into the side of the pump body casting and comprises machined end casings locating the yoke and field coil assembly, housing for the brush gear, and an armature with an extended drive shaft; the whole forming a complete unit. Two tie-bolts clamp the end casings and yoke assembly together. The drive-end motor casing houses the drive-end ball bearing, and the commutator-end motor casing houses the commutator-end ball race which is retained in a floating housing. Both bearings are prepacked, during manufacture, with an anti-freeze/high melting point grease and cannot be relubricated.

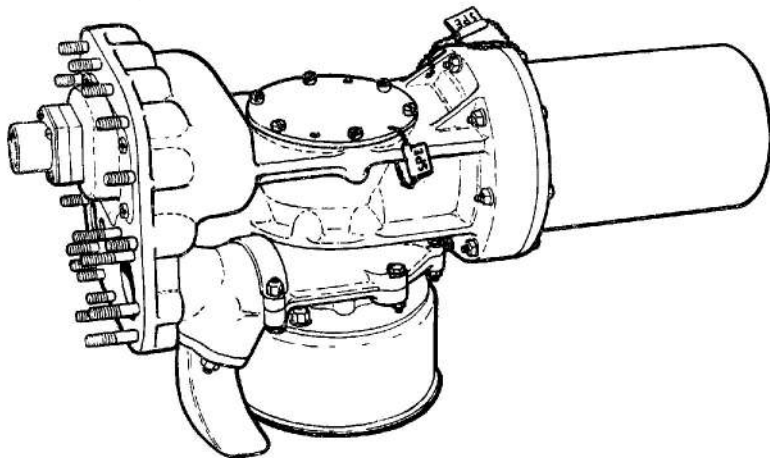

Fig. 1. External view of typical SPE.404 fuel booster pump

## DESCRIPTION

### General

2. A typical SPE.404 fuel pump is illustrated in Fig. 2 and 3. The basic pump design is a self-contained unit comprising two main sub-assemblies :

- (1) The motor unit
- (2) The pump unit

### Motor unit

3. The motor unit is a totally enclosed compound wound, two pole machine designed to operate on a 112V d.c. supply and

5. Brush gear is of unit construction to facilitate assembly, the two brush boxes being secured to a Bakelite carrier. Each box is fitted with a single brush. The motor unit is totally enclosed in a flanged light alloy casing and is sealed against the ingress of fuel by a synthetic rubber joint ring and seal rings, which are secured by a clamping bolt ring to the pump casting.

### Pump unit

6. The main pump casting houses the gland which prevents fuel ingress into the gear chamber and motor unit. The vertical

**RESTRICTED**

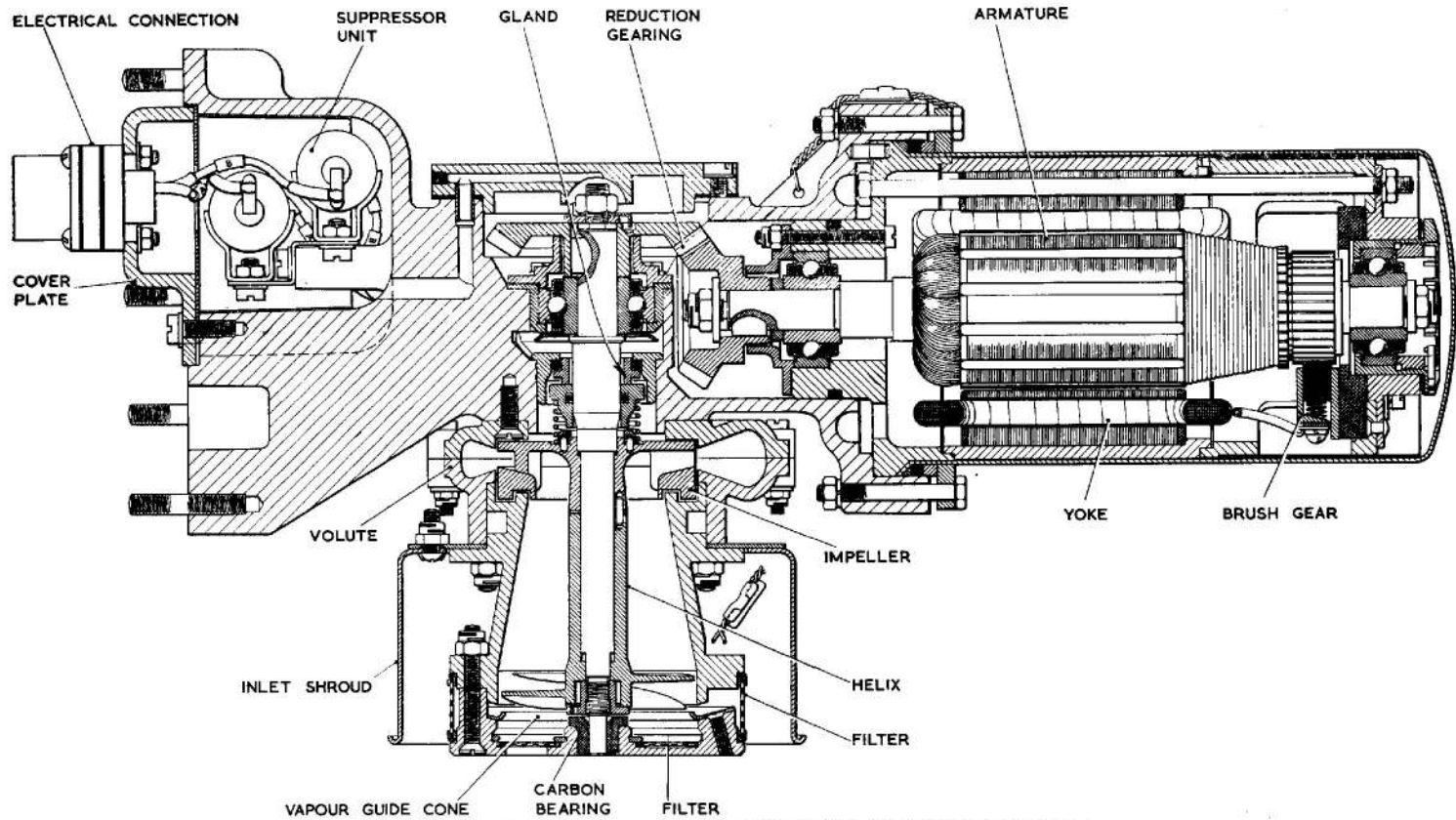

Fig. 2. Sectional view of typical SPE.404 fuel booster pump

RESTRICTED

pump shaft is supported by a plain, fuel lubricated carbon bearing at its lower end and by a shielded ball bearing at its upper end; the upper bearing is retained in a circular housing. The spiral bevel gear keyed to the top end of the shaft.

7. The carbon seating forming the rotary component of the main gland is recessed into the upper surface of the centrifugal impeller, which is closely contained within the spiral volute formed from two castings bolted together and secured to the base of the pump body casting. A short outlet casting connects the upper end of the volute to the delivery outlet in the mounting face of the pump. Shims are used to control the clearance between the centrifugal impeller and the volute casting. Any fuel which seeps past the gland is conducted through cored channels in the pump casting and then through external piping to atmosphere. A thrower is fitted above the gland as an added protection against fuel seepage up the pump shaft into the upper bearing and gear box.

8. An impeller helix is fitted to the pump shaft at the mouth of the truncated conical helix casing, which forms a fuel chamber between the two impellers. The helix is spaced from the pump shaft plain carbon base bearing by shims, the circular housing

for the base bearing being designed so that when secured to the helix casing, a fuel inlet to the pump is formed between the two castings.

#### Filters

9. Wire gauze filters completely surround the fuel inlet to the impeller and prevent the entry of large particles of foreign matter into the system. A vapour guide cone is fitted to the base bearing casting and, in conjunction with the rotation of the helix, assists in separating air bubbles and fuel vapour, which may be evolved, from the main fuel stream before they can reach the centrifugal impeller and cause vapour locking of the pump. The fuel inlet is completely surrounded by a shroud which assists the pump to withdraw the maximum amount of fuel from the tank.

#### By-pass valve

10. A by-pass valve is incorporated in the pump design to prevent an excessive drop in fuel delivery pressure when fuel is being drawn from the tank by the engine driven pump, and the fuel booster pump is idle. This valve takes the form of a simple hinged plate mounted at the junction of an irregularly shaped by-pass body casting and the outlet casting. The valve is normally

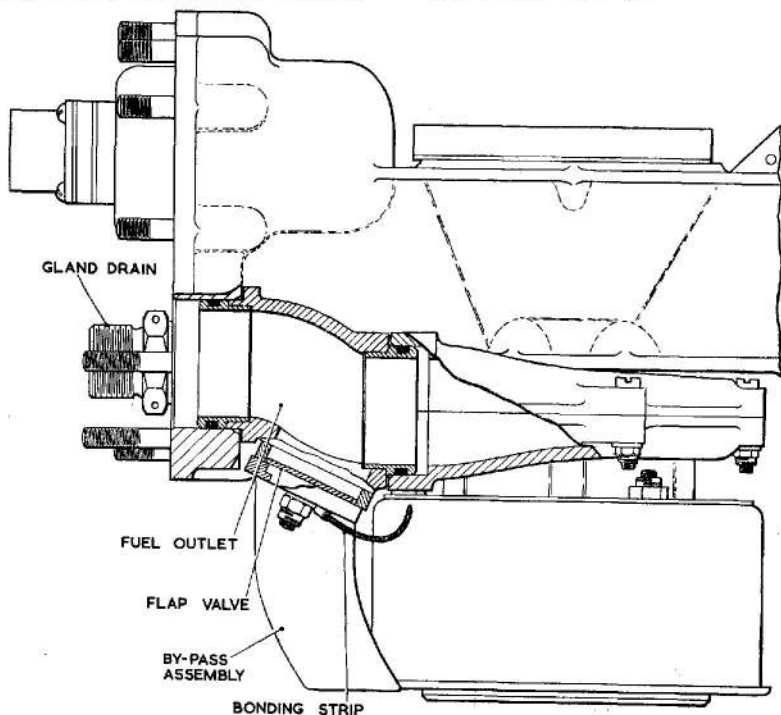

Fig. 3. Sectional view of by-pass valve

**RESTRICTED**

held closed by the pressure of the fuel being delivered by the booster pump, but is opened by the suction of the engine pump when the booster pump is idle. When the booster pump is being used solely as a transfer pump, a blanking plate is fitted over the by-pass valve seating.

#### Radio interference noise suppressors

11. Radio interference noise suppressors are included in the internal electrical circuit of the pump and are contained in a compartment of the main pump body casting; a cover plate in the mounting face of the pump provides a means of access to the suppressors. This cover plate also carries the electrical supply connection to the pump.

### OPERATION

12. When the pump motor is energised, fuel from the tank enters the pump through the wire mesh filters, on the underside of the impeller helix. The helix, driven by the motor unit through right-angled bevel gearing, draws the fuel stream into the centrifugal impeller, from which it is forced into the spiral volute and thence through the pump outlet into the fuel delivery line.

13. Under conditions in which the flow from the pump is low due to reduced engine requirements, the impellers continue to rotate at approximately normal speed without causing any excessive increase in fuel delivery pressure.

14. When the pump is idle, the delivery pressure on the top surface of the by-pass valve is relieved, enabling the suction of the engine driven pump to open the valve and draw fuel from the tank without passage through the impeller system of the pump.

### REMOVAL AND INSTALLATION

#### Removal

15. Before attempting to remove a pump, ensure that the tank has been drained of fuel and that the electrical supply to the pump has been switched off.

16. The precise method of removing a

SPE.404 pump is detailed in the appropriate Aircraft Handbook. In general terms it will consist of disconnecting the fuel delivery pipe connection from the stud ring on the pump mounting face, disconnecting the gland drain pipe and removing the electrical connection socket from the plug on the capacitor housing cover. The pump can then be removed by releasing the mounting plate from the stud ring of the aircraft fuel tank. Do not attempt to remove the pump from the mounting plate until it is clear of the tank.

#### Pre-installation checks

17. The installation of all new pumps must be preceded by the following checks.

(1) Ensure that the pump has not been stored for longer than the specified maximum period (i.e. 12 months in the original packing and carton as supplied by the pump manufacturer, or 3 years where special packing has been provided). Pumps stored for periods in excess of these maxima must not be used without being dismantled, examined and tested as detailed in Vol. 6.

(2) Inspect the exterior of the pump for evidence of damage, security of locking wires, general cleanliness and corrosion. Blend out slight areas of corrosion and apply an approved protective finish (chromic acid solution) to the unprotected area.

(3) Check that transit plugs have been removed from the delivery outlet stud ring, gland drain union and electrical connection socket and that tape or any other protective material has been removed from around the inlet filter. Check that the base filter is clear.

(4) It is advisable to make a starting check on the pump before installation. Apply a 112V d.c. electrical supply through the electrical connection. The pump must start immediately. Repeat the test several times. If the pump fails to start immediately on any check it should be returned to an overhaul base for further testing using approved equipment.

**RESTRICTED**

## Installation

18. The above pre-installation checks apply to all aircraft installations of these pumps. For detailed procedure covering installation in a particular aircraft, reference should be made to the relevant Aircraft Handbook.

19. As a general example, installation in the aircraft will comprise the following operations:

- (1) Fitting a new joint washer between the pump mounting flange and the mounting plate using an approved sealing compound on both faces of the washer.
- (2) Securing the pump to the mounting plate with twelve 2-B.A. nuts and lockwashers, omitting fixing at the six delivery outlet stud positions.
- (3) Fitting a new joint washer between the pump mounting plate and the fuel tank stud ring, using an approved sealing compound on both faces of the washer, and securing the pump mounting plate to the tank stud ring.
- (4) Fitting a new joint washer over the stud ring of the delivery outlet, using an approved sealing compound on both faces of the joint washer. Connecting the fuel delivery line, and securing it with six 2-B.A. nuts and lock-washers.
- (5) Reconnecting the gland drain pipe, ensuring when relevant that the open end of the latter faces towards the rear of the aircraft to prevent possible pressurisation in flight.
- (6) Reconnecting the electrical supply to the pump socket.
- (7) Wire-locking all pipe connections, union nuts, etc.

## SERVICING

### Routine inspection

20. At routine inspections the following procedure applies:

- (1) Inspect all the pipe connections and wire-locking to the pump. Check the joints between the mounting plate and the tank, between the pump and the mounting plate and between the delivery outlet connector and the pump, for leakage. Correct as necessary.

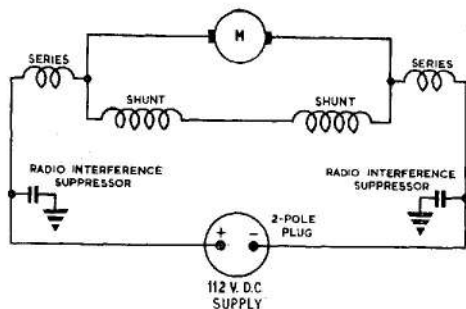

Fig. 4. Circuit diagram

- (2) Test the pump as detailed in para. 22-28. If the pump performance is found to be unsatisfactory in any way, the pump must be removed from the aircraft and a new or reconditioned unit fitted. No in-situ maintenance is possible.
- (3) Ensure that the by-pass valve is functioning correctly by completing relevant tests detailed in the appropriate Aircraft Handbook.

21. At the periods laid down in the appropriate Servicing Schedules, all pumps are to be replaced by new or reconditioned units drawn from Stores. Faulty and time expired pumps must be returned to a Maintenance Unit or to the manufacturer for repair.

### Electrical test

22. A routine electrical test in accordance with the appropriate Servicing Schedule should be made to ascertain that the motor unit is functioning satisfactorily. These tests must be made with the motor unit on load—i.e. immersed in and pumping fuel. The pump must be replaced by a new or reconditioned unit if there is any indication of erratic performance—e.g. excessive current consumption.

### 'No fuel flow' test

#### Note . . .

*The following 'no fuel flow' electrical test is only applicable to aircraft with the necessary instrumentation. Where no test panel is provided, particular attention should be paid to the Electrical test (para. 22) and Operational test (para. 26).*

23. Ascertain the position of the aircraft pump test socket and switches by reference

**RESTRICTED**

to the relevant Aircraft Handbook. Proceed as follows :

- (1) Close all fuel cocks between the pump and engine to ensure that no fuel can flow.
- (2) Connect a suitable portable ammeter to the socket on the test panel.

**Note . . .**

*When using a clip-on type ammeter, open and close the tongs smartly prior to use to reduce the hysteresis error.*

- (3) Switch on the pump by depressing the switch on the test panel. Observe the ammeter reading for a period of not less than 30 seconds.

24. Interpret the readings obtained as follows :

- (1) A steady reading not exceeding that indicated by the graph (fig. 5) for the measured applied voltage, indicates that the motor is functioning satisfactorily.

**Note . . .**

*The graph (fig. 5) is provided as a guide to pump performances under no-flow conditions, the figures derived from it are not to be interpreted as forming a part of the approved Acceptance Test Specification for the pump.*

- (2) Current consumption in excess of the graph reading indicates either a faulty motor unit, a rise in torque loading due to the obstruction of moving parts, or a restriction of the fuel flow.

(3) A fluctuating reading indicates faulty contacts, defective brushes, faulty commutation or that bearings or other rotating parts are binding.

(4) A zero reading indicates an open circuit and is consistent with a blown fuse, defective switch, faulty wiring or a complete motor failure.

25. When the above tests have been completed, release the test switch and disconnect the ammeter.

**Operational test**

26. Subject to the electrical test being completed satisfactorily, the pump should be tested where possible for proof of performance and checked against the performance figures quoted in the appropriate appendix to this chapter. Refer to the relevant Aircraft Handbook for procedure details. Possible causes of failure to obtain the required performance, are given in Table 1.

**Gland leakage**

27. During the above tests an examination should be made of the gland drain exit for fuel leakage. The leakage must not exceed two drops per minute while the pump is running, or one drop per minute while stationary. Any leakage in excess of these figures will necessitate removal of the pump from the aircraft.

**Insulation resistance test**

28. Using a 250V constant pressure insulation resistance tester, measure the insulation resistance between the socket pins and earth. When a new pump is drawn from Stores insulation resistance must be not less than 2 megohms. After installation, due to humidity conditions prevalent in aircraft at dispersal points, the minimum permissible insulation resistance is 50,000 ohms.

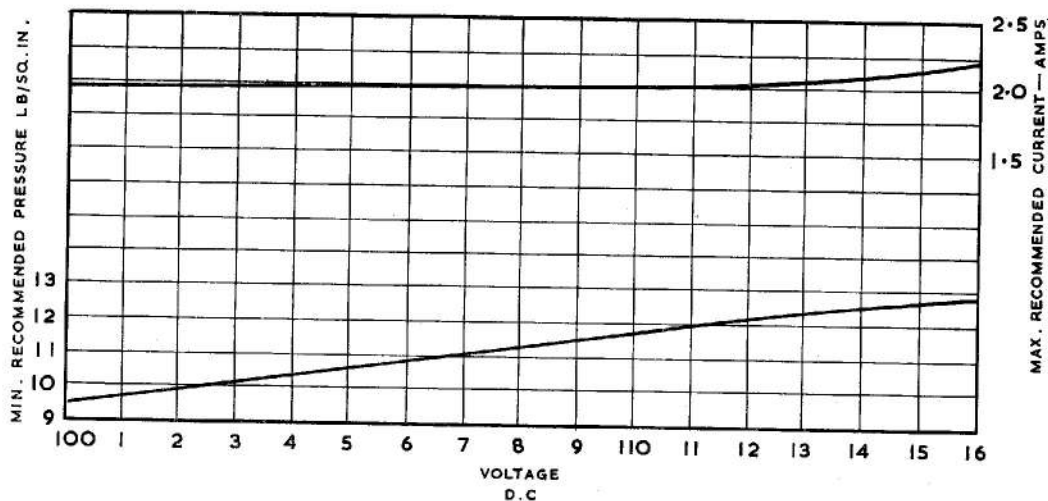

Fig. 5. "No fuel flow" electrical test graph

TABLE 1  
Faults, possible causes and rectification

Fault	Possible cause	Rectification
Gland leakage	(1) Bad finish between gland seal faces. (2) Insufficient pressure between gland seal faces.	All these conditions require that the pump is removed from the aircraft and returned to a Maintenance Unit or to the pump manufacturer for repair.
Excessive current	(1) Excessive loading on the metallic bellows gland, (2) Faulty motor unit, (3) Fouling of impeller system by foreign matter.	
Low delivery pressure Pressure surges	(1) Faulty motor unit, (1) Tight or pre-loaded bearings. (2) Excessive loading on the metallic bellows gland.	
Low insulation resistance	Dampness in motor windings.	

RESTRICTED

## Appendix 1

## PUMPS, FUEL, SPE.404 Mk. 1D, 1E, 1F and 1G

Pump, fuel, SPE.404 Mk.1D	...	...	...	...	Ref. No. 5UE/6597
Pump, fuel, SPE.404 Mk.1E	...	...	...	...	Ref. No. 5UE/6876
Pump, fuel, SPE.404 Mk.1F	...	...	...	...	Ref. No. 5UE/6876
Pump, fuel, SPE.404 Mk.1G	...	...	...	...	Ref. No. 5UE/7475
Voltage limits	...	...	...	...	100/116V d.c.
Rated voltage	...	...	...	...	112V d.c.
Rated output at 110V d.c.	...	...	...	...	400 gal./hr.
Delivery pressure at rated output/110V d.c.	...	...	...	11 lb./in. <sup>2</sup> —(Mk. 1D and 1E)	
				10 lb./in. <sup>2</sup> —(Mk. 1F and 1G)	
Max. current consumption at rated output/110V d.c.	...	...	...	...	2.2A max.
Max. 'no flow' delivery pressure at 116V d.c.	...	...	...	...	29 lb./in. <sup>2</sup>
Minimum 'no flow' delivery pressure	...	...	...	...	See Fig. 5, basic chapter.
Electrical connection (Plessey 2CZ.140052)	...	...	...	...	Ref. No. 5X/6720
Delivery outlet	...	...	...	Special—stud ring on pump mounting face.	
Gland drain tapping	...	...	...	...	$\frac{3}{8}$ in. B.S.P.
Weight of unit	...	...	...	...	8.5 lb. approx.

## Type differentiation

1. Basic differences between the various marks of SPE.404 pumps covered by this appendix are as follows :

**SPE.404 Mk. 1D** Basic design covered in this chapter.

**SPE.404 Mk. 1E** Generally similar to Mk. 1D pump but fitted with improved gear and pinion and a repositioned breather hole outlet from the gear box to prevent grease leakage from the gear box when the pump is stored in an inverted position.

**SPE.404 Mk. 1F** Generally similar to SPE.404 Mk. 1D but incorporates a locating arrangement to ensure correct re-assembly of the commutator end motor casing after initial speed setting. The brush as-

sembly is retarded to 27° to give correct motor speed and reduce the rated delivery pressure to 10 lb./in.<sup>2</sup>. An insulating strip is included between the brush box assembly and the commutator end motor casing to eliminate possible short circuiting between the brush boxes through the rivets and the motor end casing.

**SPE.404 Mk. 1G** Generally similar to SPE.404 Mk. 1F but fitted with a Flexibox mechanical seal in place of the metallic bellows type gland. An improved helix locking arrangement and a gear box cover with a bonded rubber seal are also fitted.

RESTRICTED

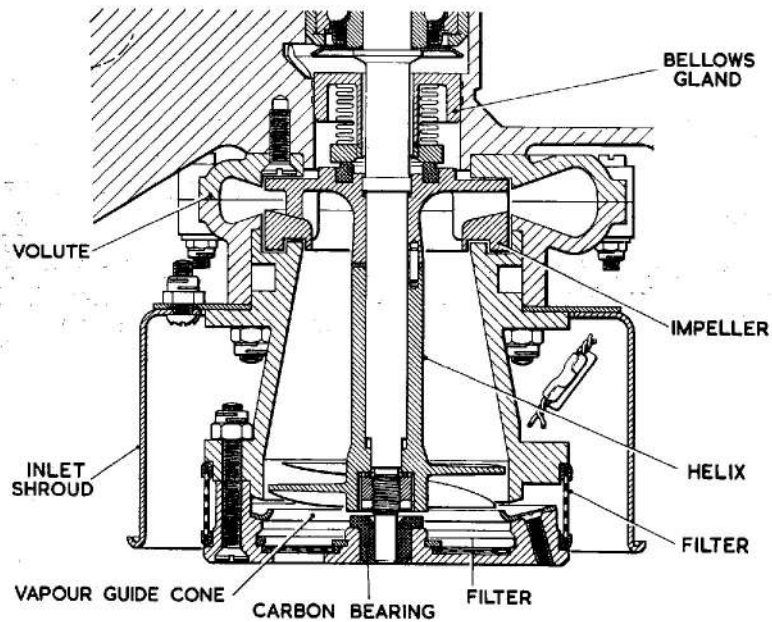

Fig. 1. Sectional view of SPE.404 Mk.IF pump unit

**RESTRICTED**

This file was downloaded  
from the RTFM Library.

Link: [www.scottbouch.com/rtfm](http://www.scottbouch.com/rtfm)

Please see site for usage terms,  
and more aircraft documents.



Instrument panel  
from a  
Mikojan Provoost  
(XP558)