

Cancelled now AP 113F-0428-6
do not destroy

PUMP, WATER-GLYCOL, SPE.330 WG

LIST OF CONTENTS

	Para.		Para.
Introduction	1	Assembling the motor casing to the lower bearing housing	18
Reconditioning		Testing the motor	19
Special tools and equipment ...	2	Adjusting the thrower shimming (bellows loading)	20
Dismantling		Assembling the pump body assembly to the motor	21
Removing the electrical connection and the motor breather	3	Assembling the impeller to the rotor shaft	22
Removing the base casting assembly	4	Assembling the base casting to the pump body	23
Removing the impeller	5	Assembling the electrical connection and the motor breather	24
Removing the pump body	6	Testing	
Dismantling the motor unit	7	General	25
Cleaning, examination and repair		Test equipment	26
Cleaning	8	Schedule of motor tests	
Examination		Insulation resistance tests	27
General	9	Checking the motor speed and direction of rotation	28
Detail procedure	10	Schedule of pump tests	
Repair		Insulation resistance test	29
Light scores, burrs and surface corrosion	11	Gland leakage test	30
Renewing damaged studs	12	Starting test	31
Repairing varnished surfaces (motor)	13	Dry running test	32
Renewing anti-corrosive lacquer ...	14	Endurance test	33
Repairing anodic surface protection	15	Insulation resistance test	34
Renewing the bellows gland	16	Calibration test	35
Assembling			
Assembling the rotor to the lower bearing housing	17		

LIST OF TABLES

	Table		Table
Special tools and equipment ...	1	Schedule of fits, clearances and repair tolerances	3
Detailed examination of components	2	Fault diagnosis	4

LIST OF ILLUSTRATIONS

	Fig.		Fig.
Exploded view	1	Setting the bellows gland pressure ...	5
Details of lacquered surfaces	2	Setting the impeller clearance	6
Removing the bellows gland	3	Diagrammatic layout of a typical test rig.	7
Assembling the bellows gland	4		

RESTRICTED

PUMP, WATER-GLYCOL, SPE.330WG

Introduction

1. A general description of the SPE.330 W.G. series water-glycol pumps is given in A.P.4343D, Vol. 1, Book 2, Sec. 11, Chap. 2. Reconditioning instructions are given in this chapter for the SPE.330WG Mk. 1 water-glycol pump and appendices will be added as required to cover the differences in procedure for any later pumps in the series.

RECONDITIONING

Special tools and equipment

2. In addition to the standard bench tools, the special tools listed in Table 1 and the equipment detailed in para. 26 are required to overhaul and test the SPE.330 WG Mk. 1 pump.

TABLE 1
Special tools and equipment

Nomenclature	Part No.	Fig.
Thrower nut spanner	SPE.19532	—
Impeller spanner	SPE.23121	—
Gland extractor	SPE.19519	3
Guide bush	SPE.19520	3
Pump casting location	SPE.23122	3
Pressure block	SPE.19522	4
Spring-loaded casting and gland location fixture	SPE.23123	4
Weight	SPE.19524	5
Guide bush and locking screw	SPE.19526	5
Gauge assembly	SPE.19527	5
Calibrated fan	SPE.23119	—
Baseplate	SPE.10766	—

DISMANTLING

Removing the electrical connection and the motor breather

3. (1) Remove the screws (36) and the shakeproof washers (37) and withdraw the breeze plug (38) to gain access to the motor leads.
- (2) Unsolder the leads from the

breeze plug pins and remove the plug and the motor breather (39).

Note . . .

Do not remove the cable markers (51) from the motor leads.

Removing the base casting assembly

4. (1) Remove the four special bolts (25) and nuts (35) securing the base castings assembly (30) to the pump body assembly (20).
- (2) Remove the nuts (35) and spring washers (34) from the base casting and pump body studs, then remove the base casting and the gasket (28).

Removing the impeller

5. (1) Using the special spanner, SPE 23121, to hold the impeller (27) remove the impeller nut (29).

(2) Remove the three screws (5) and remove the motor top end bearing cover (6).

(3) Hold the rotor nut (10) to prevent the rotor turning and, using the special spanner, unscrew the impeller (27) Remove the impeller shim(s) (26).

Note . . .

Should the rotor nut slacken before

~~RESTRICTED~~

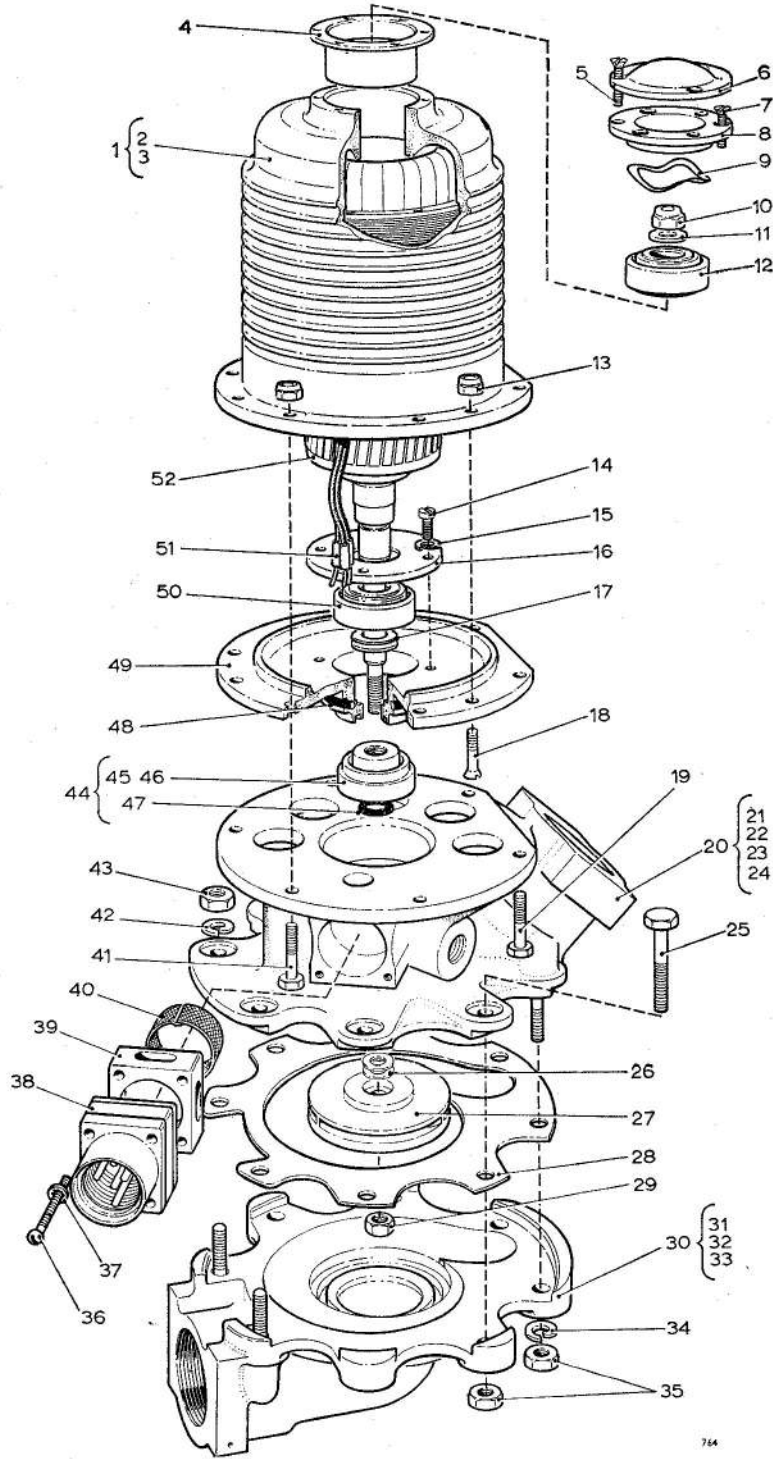

Fig. 1. Exploded view

~~RESTRICTED~~

KEY TO FIG. 1
(Exploded view of pump)

1 MOTOR CASING AND STATOR ASSEMBLY.	27 IMPELLER
2 MOTOR CASING	28 GASKET
3 STATOR ASSEMBLY	29 SPECIAL (IMPELLER) NUT
4 UPPER BEARING HOUSING	30 BASE CASTING ASSEMBLY
5 SCREW	31 BASE CASTING
6 TOP END BEARING COVER	32 BASE CASTING INSERT
7 SCREW	33 SPECIAL STUD
8 TOP END BEARING RING	34 SPRING WASHER
9 THRUST WASHER	35 NUT
10 SELF-LOCKING (ROTOR) NUT	36 SCREW
11 CLAMPING WASHER	37 SHAKEPROOF WASHER
12 BEARING (UPPER)	38 BREEZE PLUG
13 SELF-LOCKING NUT	39 MOTOR BREATHER
14 CHEESE HEAD SCREW	40 BREATHER GAUZE
15 SPRING WASHER	41 SPECIAL BOLT
16 LOWER BEARING CLAMP PLATE	42 SPRING WASHER
17 SHIM(S) (THROWER)	43 NUT
18 SCREW	44 THROWER ASSEMBLY
19 BOLT	45 THROWER NUT
20 PUMP BODY ASSEMBLY	46 SEAL SEAT
21 PUMP CASTING	47 SEALING RING
22 BELLOW ASSEMBLY	48 SEALING RING
23 STUD	49 LOWER BEARING HOUSING
24 STUD	50 BEARING (LOWER)
25 SPECIAL BOLT	51 CABLE MARKER
26 SHIM(S) (IMPELLER)	52 ROTOR ASSEMBLY

the impeller, the rotor shaft may be gripped using two thin locknuts tightened against each other in place of the rotor nut.

Removing the pump body

6. Remove the six nuts (13), the two special bolts (41) and the four bolts (19) and separate the pump body assembly (20) from the motor, carefully withdrawing the motor leads through the pump body.

Note . . .

Ensure that the motor lead cable markers (51) are not displaced during this operation.

Dismantling the motor unit

7. (1) remove the three self-locking nuts (13) and countersunk screws (18) and carefully separate the motor casing and stator assembly (1) from the rotor (52) and lower bearing housing (49). Remove the thrust washer (9).
- (2) Remove the three countersunk screws (7) and remove the top-end bearing ring (8) and the upper bearing housing (4) from the motor casing (2).
- (3) Remove the rotor nut (10) and clamping washer (11) and, using

special spanner, SPE.19532, remove the thrower assembly (44) from the rotor (52). Retain the shims (17).

Note . . .

The rotor shaft may be gripped using two 2 BA nuts tightened together.

(4) Remove the upper bearing (12) and the lower bearing housing (49) from the rotor.

(5) Remove the screws (14) and spring washers (15) and remove the lower bearing clamp plate (16) and the ball bearing (50) from the lower bearing housing.

CLEANING, EXAMINATION AND REPAIR

Cleaning

8. Clean all parts except the electrical connection and ball bearings in gasoline, no lead, using a soft bristle brush where necessary to remove stubborn grease or dirt. Remove surplus gasoline with dry compressed air and allow to dry for several hours. Finally dry the parts in a

~~**RESTRICTED**~~

ventilated oven at approximately 100 deg. C. (212 deg. F.).

Examination

General

9. (1) Examine all parts for cleanliness, distortion, cracks, scores, burrs, corrosion and, where applicable, the condition of the protective finish.
- (2) Examine all threads for serviceability.

- (3) Examine the electrical cable and coil insulation for cleanliness, chafing, cracks, cuts, signs of overheating, fluid soakage and general deterioration.

Detail procedure

10. Parts should be inspected in accordance with Table 2 and checked for conformity with the Schedule of Fits, clearances and repair tolerances given in Table 3.

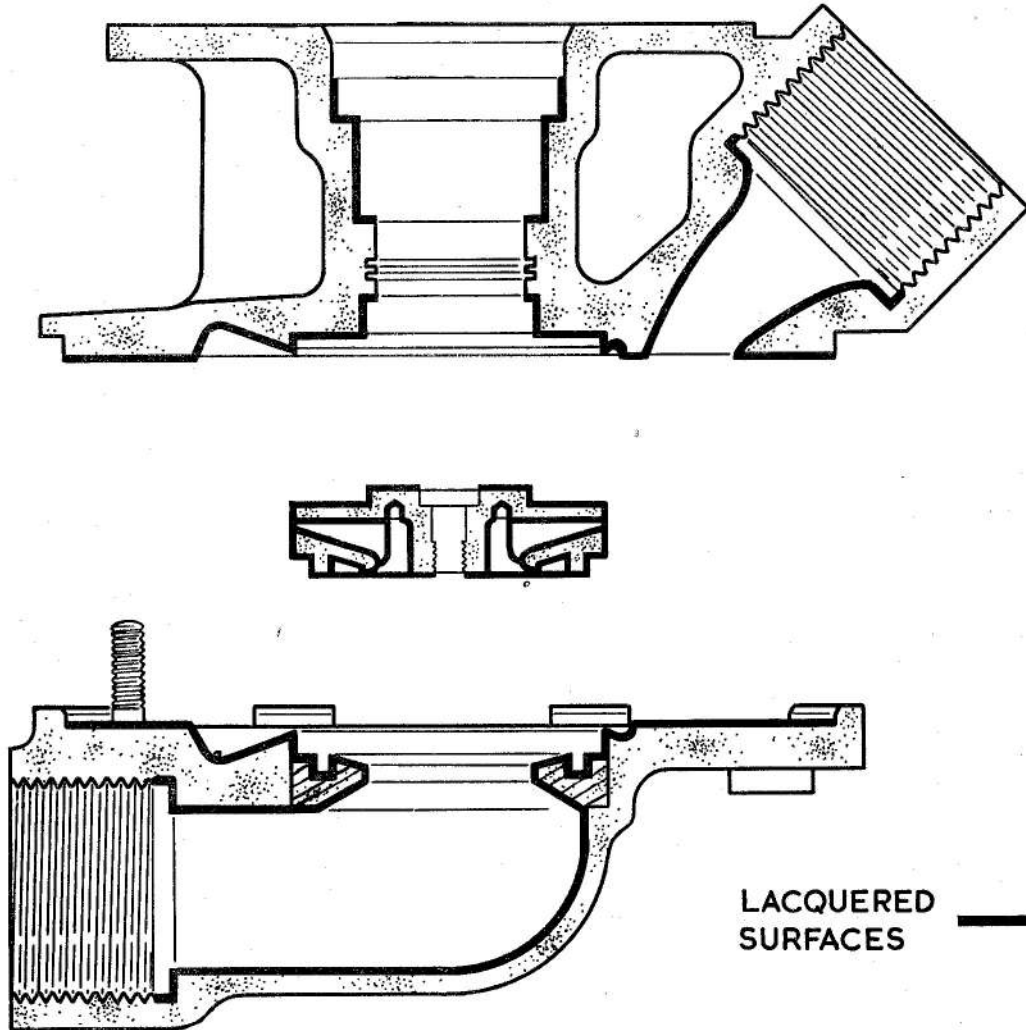

Fig. 2. Details of lacquered surfaces

RESTRICTED

TABLE 2
Detailed examination of components

Item	Examination	Action if faulty
Motor casing and stator assembly	Using a suitable ohmmeter, check that the resistance across any two phases is 16.75 to 16.85 ohm at 20 deg.C.	Reject assembly
	Using a 500V insulation resistance tester, check that the insulation resistance between the windings collectively and the frame is not less than 2 megohm.	Repeat cleaning process (para. 8), with prolonged drying if necessary, then re-check. If the fault persists, reject the assembly.
Rotor assembly	Check that the rotor shaft eccentricity is within the specified limit.	Reject assembly.
Thrower assembly	Examine the carbon seal for cracks, scores or other damage, paying particular attention to the seal face.	Light scores in the seal face may be removed by lapping, provided the dimension laid down in Fits and clearances is not exceeded. Other damage will entail rejection
	Remove and discard the rubber sealing ring.	
Pump body and base casting assemblies.	Check the condition of the anti-corrosive lacquer.	Renew lacquer, after removing corrosion, as detailed in para. 14.
	Examine the bellows gland seal face and bellows for signs of damage.	Renew bellows gland as detailed in para. 16.
	Examine the attachment studs for security and damage.	Renew damaged studs as detailed in para.12.
Impeller	Check the condition of the anti-corrosive lacquer.	Renew lacquer, after removing corrosion, as detailed in para. 14.
Ball bearings	It is recommended that the bearings are renewed on reconditioning.	

~~RESTRICTED~~

TABLE 3
Schedule of fits, clearances and repair tolerances

Part and description	Dimension New	Permissible worn dimension	Clearance new	Permissible worn clearance	Remarks
ROTOR SHAFT IN BALL BEARINGS					
Shaft — dia.	$\frac{0.3541 \text{ in.}}{0.3537 \text{ in.}}$	—	Interf $\frac{0.0001 \text{ in.}}{0.0006 \text{ in.}}$	0.0006 in.	Selected to give a hand push fit.
Bearing — bore	$\frac{0.3540 \text{ in.}}{0.3543 \text{ in.}}$	—	Clear		
BALL BEARING IN LOWER BEARING HOUSING					
Bearing — dia.	$\frac{1.0236 \text{ in.}}{1.0233 \text{ in.}}$	1.0233 in.	$\frac{0.0004 \text{ in.}}{0.0011 \text{ in.}}$	0.0011 in.	
Housing — bore	$\frac{1.0240 \text{ in.}}{1.0244 \text{ in.}}$	1.0244 in.			
BALL BEARING IN UPPER BEARING HOUSING					
Bearing — dia.	$\frac{1.0236 \text{ in.}}{1.0233 \text{ in.}}$	1.0233 in.	$\frac{0.0004 \text{ in.}}{0.0010 \text{ in.}}$	0.0010 in.	
Housing — bore	$\frac{1.0240 \text{ in.}}{1.0243 \text{ in.}}$	1.0243 in.			
IMPELLER					
Clearance	—		$\frac{0.0060 \text{ in.}}{0.0100 \text{ in.}}$	—	Obtained by shimming.
ROTOR					
Eccentricity	—	1.001 in.	—	—	
THROWER ASSEMBLY					
Overall length	$\frac{0.5315 \text{ in.}}{0.5295 \text{ in.}}$	0.5290 in.	—	—	

~~RESTRICTED~~

Repair

Light scores, burrs and surface corrosion

11. (1) Light scores, burrs and surface corrosion may be removed using fine grade emery cloth.

Note . . .

Where the anodic film or other anti-corrosive treatment is damaged, the surface should be reprotected, after repair, in accordance with current procedure, or, as detailed in para. 13-15.

- (2) Damaged threads may be dressed using the appropriate size tap or die.

Renewing damaged studs

12. (1) Remove the damaged stud(s) from the casting using any suitable approved method.
- (2) Apply Hermeticoll jointing compound to the mating threads of the replacement stud.

Note . . .

In all cases, the shorter stud thread engages with the casting. In the pump body, the longer stud should be fitted in the tapped hole nearest the volute wall.

- (3) Fit the stud to the casting and screw fully home.
- (4) Remove all excess jointing compound extruded from the stud hole.

Repairing varnished surfaces (motor)

13. This treatment applies to the rotor laminations and the stator bore. Proceed as follows:—

- (1) Ensure that the surface to be varnished is clean and dry.
- (2) Brush on one coat of air drying varnish, I.C.I. F.268-683 (M of S Spec. TS 188B) and allow to dry at room temperature.

Renewing the anti-corrosive lacquer

14. This instruction applies to the internal surfaces of the pump body and base casting normally in contact with water-glycol and all surfaces of the impeller except the bore. Refer to Fig. 2.

Note . . .

Small, isolated areas of damaged finish

may be rectified by brush application of lacquer, after degreasing with gasoline no lead, provided the anodic film on the base metal is undamaged. Where pitting of the lacquer is evident or where damage is extensive, the complete coating must be removed to allow inspection of the anodic film. The bellows gland must be removed from the pump body as detailed in para. 16 before lacquering.

- (1) Soak the component in trichloroethylene, then clean off the lacquer using a bristle brush and, where necessary, a wooden scraper. Continue the cleaning process until all traces of lacquer have been removed.
- (2) Allow the component to dry, then mask off the areas to be kept clear of lacquer.
- (3) Dip the component in Araldite 985E varnish (Blue Tinted Lacquer, Ref. No. 444/219, Gittings and Hill Ltd., Birmingham) then allow to drain. Turn the part occasionally during the first few minutes to prevent the formation of sags and runs.

Caution . . .

Keep the part clear of dust and moisture.

- (4) Allow the lacquer to air dry until tacky then remove the masking and clean off stray varnish.

Note . . .

The lacquer should be smooth, even, and free from sags, runs and air pockets.

- (5) Bake the component in an oven at about 200 deg. C (392 deg. F) for 60 minutes or 220 deg. C (428 deg. F.) for 30 minutes.

Repairing anodic surface protection

15. This instruction details the Alchromate treatment for surface areas where the anodic film has been removed.

Caution . . .

Exercise care when handling the chemicals used in this process. Rubber gloves and an apron should be worn.

- (1) Ensure that all surface corrosion has been removed from the part to be

RESTRICTED

treated, then thoroughly degrease the surface using trichlorethylene and allow to dry.

(2) Finally clean the part in hot diluted Woec XXX detergent (R. S. Waddington, Wandsworth), mixed in the ratio of 4 parts hot water to 1 part detergent.

Note . . .

Do not handle part(s) after cleaning.

(3) Mix a suitable quantity of Alchromate solution in the proportion of 1 part Alchromate concentrate to 2-4 parts water in a stainless steel, plastic or neoprene lined container.

(4) Using a nylon brush or synthetic sponge, apply the Alchromate solution to the prepared surface until thoroughly "wetted."

Note . . .

If the surface proves persistently difficult to wet, the part should be washed in running water and dried, then re-cleaned as detailed in (1) and (2) above.

(5) Allow the surface to soak for 5 minutes, then thoroughly wash the part in clean, cold running water and allow to dry.

Note . . .

The treated surface should be free from blemishes and golden or golden-yellow in appearance.

(6) Test the treated surface by rubbing with white paper. The paper may show a slight stain but should not rub through the Alchromate film.

Renewing the bellows gland

16. (1) Using the special tools illustrated in Fig. 3, press the bellows gland (22) out of the body.

(2) Remove all traces of jointing compound from the bellows gland locating bore.

(3) Apply Hermeticoll jointing compound to the mating faces of the new bellows gland and the pump body.

Caution . . .

Ensure that the compound does not contact the bellows gland seal ring.

(4) Using the special tools illustrated in Fig. 4, press the new bellows gland fully into the pump body. Remove excess jointing compound.

ASSEMBLING

Assembling the rotor to the lower bearing housing

17. (1) Select a bearing (50) that is a hand push fit on the lower end of the rotor (52).

Note . . .

Exercise care when handling the bearings to avoid damaging the felt seals.

(2) Fit the selected bearing to the lower bearing housing (49), then fit the lower bearing clamp plate (16) and secure with the four screws (14) and spring washers (15). Fully tighten the screws.

(3) Fit a new sealing ring (47) smeared with Silicone MS.4 grease, A339 (Ref. No. 33C/9424829) to the internal groove in the thrower nut (45).

(4) Fit the rotor to the lower bearing housing, position the shim(s) (17) and fit the thrower assembly (44) finger tight.

Assembling the motor casing to the lower bearing housing

18. (1) Position the upper bearing housing (4) and the top end bearing ring (8) in the motor casing (2). Align the attachment holes, then fit and fully tighten the three countersunk securing screws (7).

(2) Select a bearing (12) that is a hand push fit on the upper end of the rotor (52).

RESTRICTED

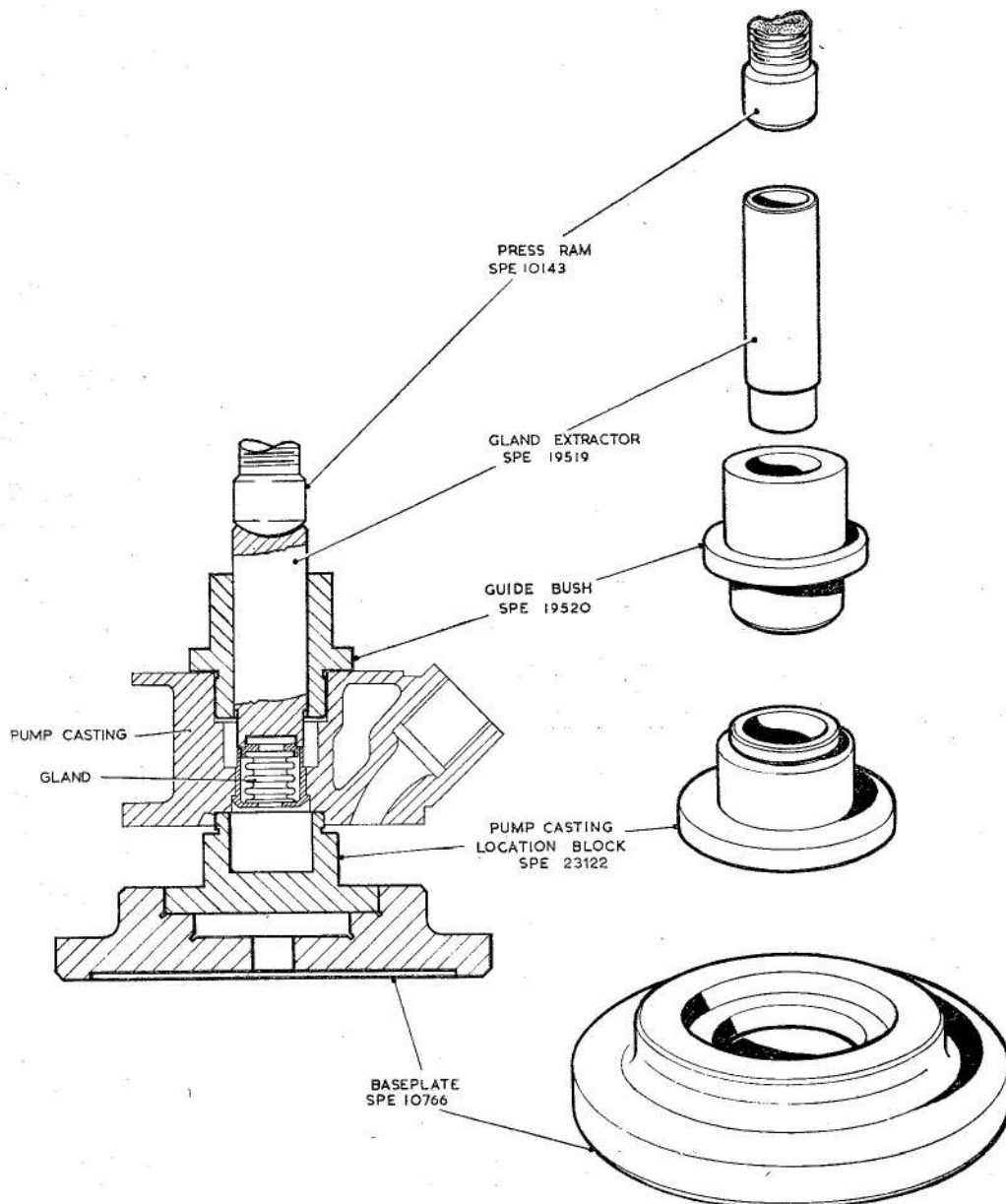

Fig. 3. Removing the bellows gland

Note . . .

Exercise care when handling the bearing to avoid damaging the felt seals.

- (3) Fit the selected bearing on the rotor and loosely assemble the clamping washer (11) and rotor nut (10).
- (4) Support the motor casing, flange uppermost, and position the thrust washer (9) in the upper bearing housing bore.
- (5) Position the previously assembled rotor and lower bearing housing in the

motor casing with the motor leads extended through the hole in the bearing housing and the upper bearing located in the upper bearing housing bore.

- (6) Align the flat on the lower bearing housing with the motor casing and fit and fully tighten the three countersunk attachment screws (18) and self-locking nuts (13).
- (7) Using the special spanner, SPE.19532, to hold the thrower, fully tighten the rotor nut (10) and the thrower (44), ensuring that the rotor

RESTRICTED

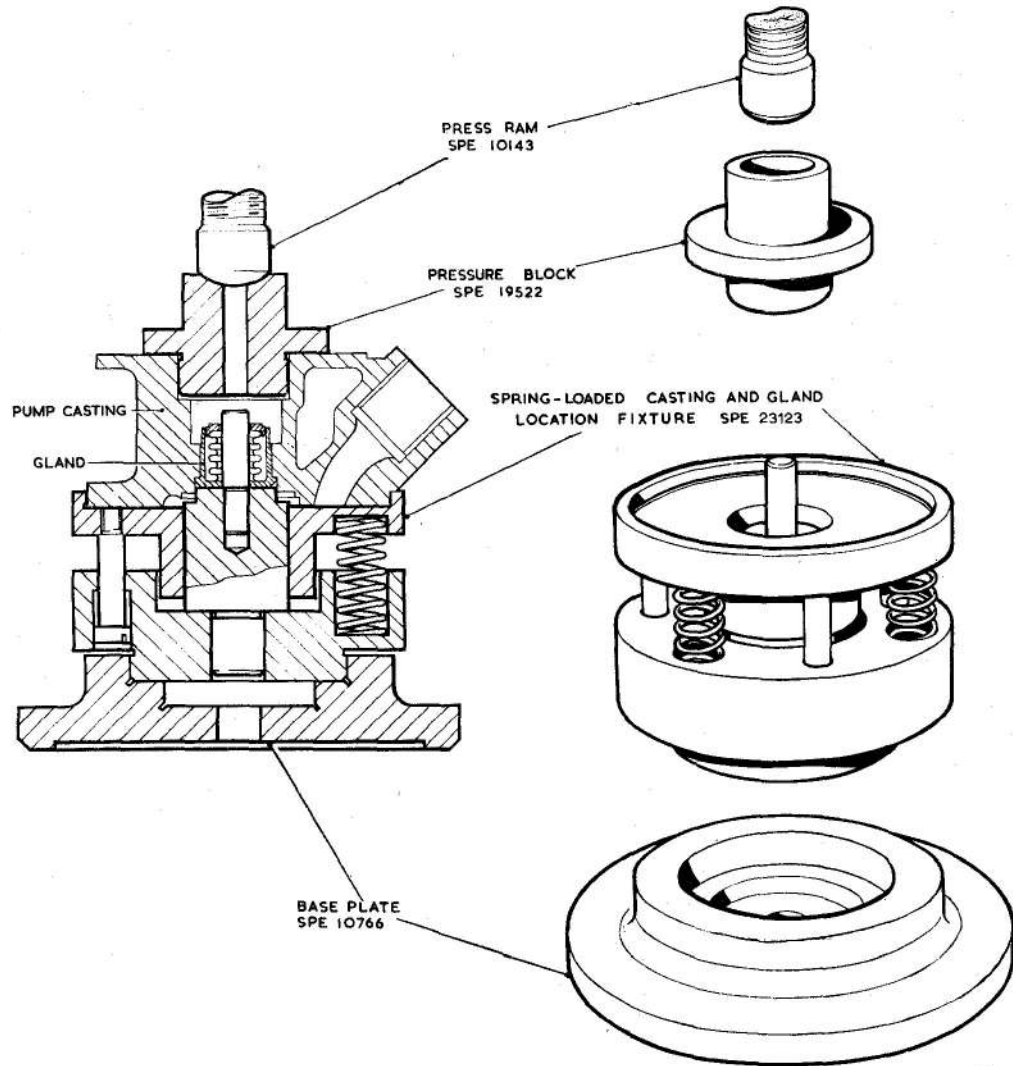

Fig. 4. Assembling the bellows gland

793

~~RESTRICTED~~

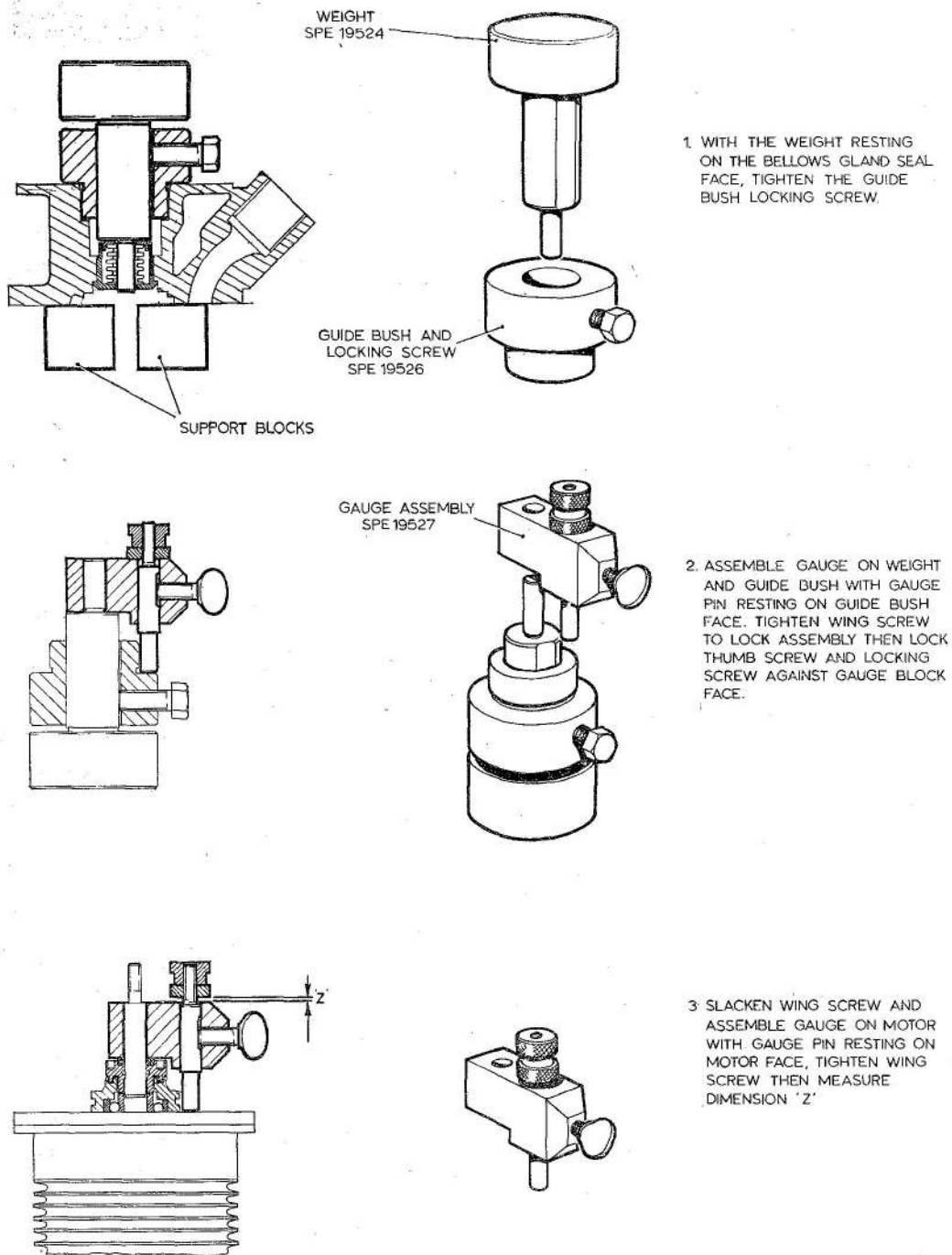

Fig. 5. Setting the bellows gland pressure

RESTRICTED

turns freely throughout the operation.
(8) Fit the top end bearing cover (6) and secure with the three countersunk screws (5).

Testing the motor

19. Carry out the insulation resistance test and motor speed test as detailed in para. 27 and 28.

Adjusting the thrower shimming (bellows loading)

20. (1) Using the special tools illustrated

in Fig. 5, calculate the thickness of shims required under the thrower nut to load the bellows gland to within the specified limits i.e. dimension 'Z.'

(2) Select shims (17) of the required total thickness.

(3) Remove the thrower assembly, fit the selected shim(s), then re-fit the thrower and fully tighten.

Assembling the pump body assembly to the motor.

21. (1) Fit a new sealing ring (48),

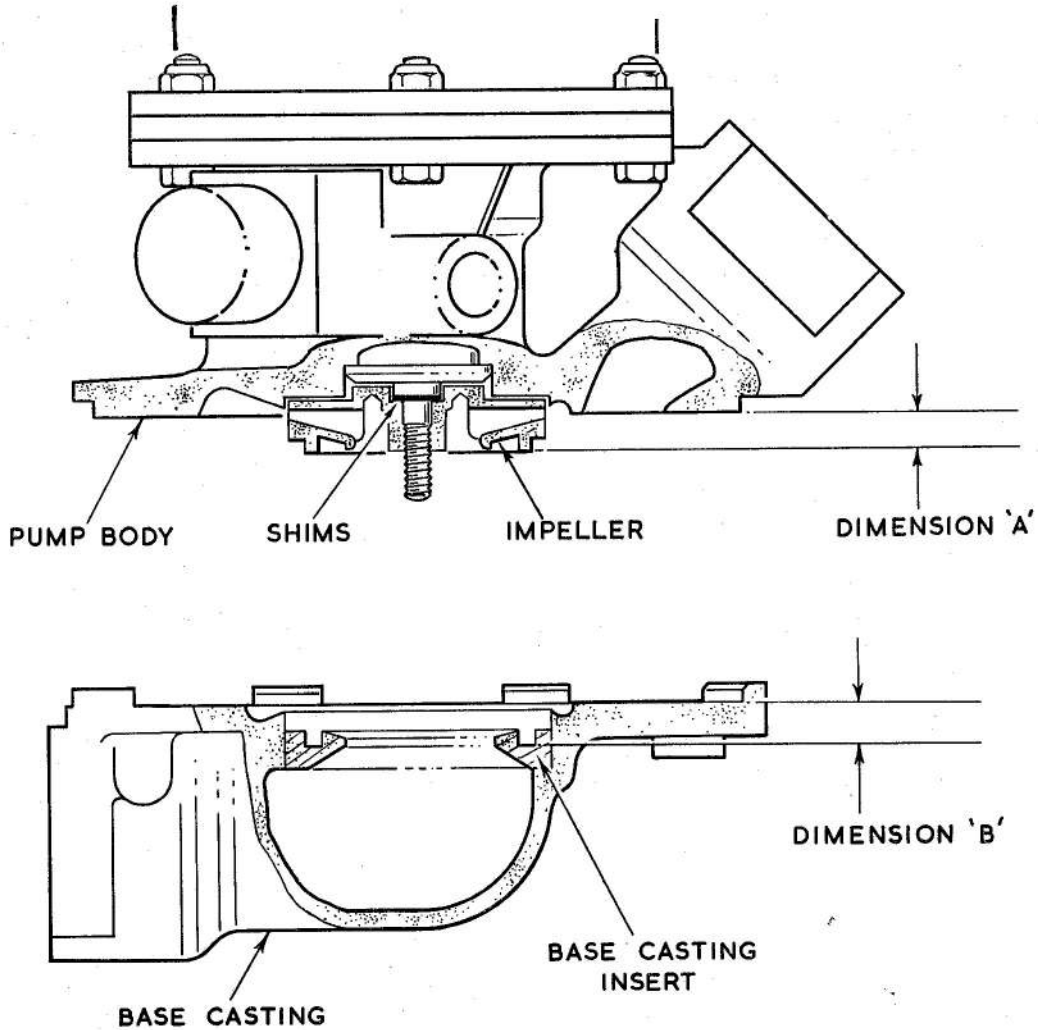

Fig. 6. Setting the impeller clearance

~~RESTRICTED~~

smeared with Silicone MS 4 grease (Ref. No. 33C/9424829), to the groove in the motor mounting spigot.

(2) Position the pump body assembly (20) on the motor with the motor leads passing through the body to the electrical connection mounting and with the flat on the motor casing flange aligned with the flat on the pump body adjacent to the outlet port.

Caution . . .

Ensure that the rotor shaft does not foul the bellows gland seal face on assembly.

(3) Loosely assemble the two special bolts (41), four bolts (19) and the self-locking nuts (13).

Note . . .

The special bolts should be fitted in adjacent holes.

(4) Progressively tighten the nuts, in diametrically opposed pairs, until fully tight.

Assembling the impeller to the rotor shaft

22. (1) Remove the screws (5) and the top-end bearing cover (6).

(2) Position the original shim(s) (26) and screw the impeller (27) on to the rotor shaft.

(3) Using a suitable spanner to hold the rotor and special spanner, SPE 23121, fully tighten the impeller.

(4) Using suitable equipment record dimensions 'A' and 'B' as shown in Fig. 6, then calculate the shimming adjustment as follows:—

$$B - A + 0.050 \text{ in.} = \text{shim adjustment}$$

(5) If necessary, remove the impeller and adjust the shim thickness by the calculated amount. Refit and tighten the impeller on completion.

(6) Fit and fully tighten the impeller nut (29).

(7) Fit the top-end bearing cover and secure with the three screws. Fully tighten the screws and lock by peening.

Assembling the base casting to the pump body.

23. (1) Position a new gasket (28) on the pump body assembly (20) with the

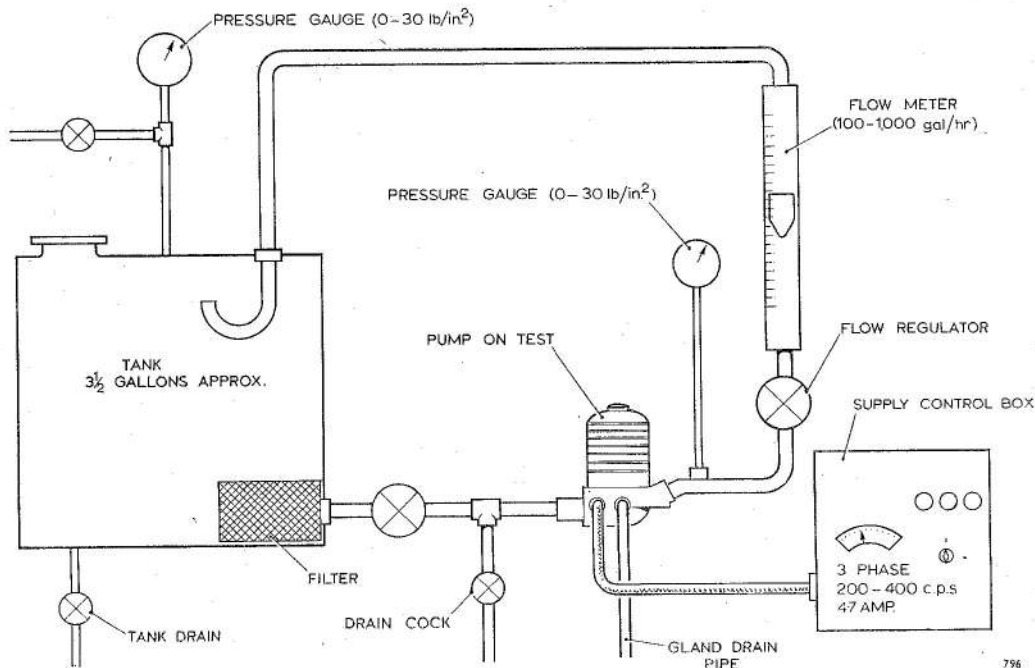

Fig. 7. Diagrammatic layout of typical test rig

RESTRICTED

holes and volute cut-out aligned.

(2) Fit the base casting assembly (30) to the pump body with the inlet port positioned diametrically opposite the outlet port and assemble the retaining nuts (35) and spring washers (34) finger tight.

(3) Fit the four nuts (35) and special bolts (25) finger tight.

Note . . .

The bolts should be fitted with the threads extending from the base casting.

(4) Tighten the nuts and bolts evenly in diametrically opposed pairs until fully tight. Wait 5 minutes to allow the gasket to 'settle' then re-tighten the nuts.

Assembling the electrical connection and the motor breather

24. (1) Fit the breather gauze (40) into the locating bore in the motor breather (39).

(2) Position the breather, gauze locating bore first, on the motor leads, and solder the leads to their respective breeze plug pins as follows:—

Lead number 1 to pin B
Lead number 2 to pin E
Lead number 3 to pin C

(3) Position the breather and the breeze plug on the pump body and fit the securing screws (36) complete with shakeproof washers (37). Fully tighten the screws.

TESTING

General

25. The complete motor must be tested in accordance with the schedule of motor tests detailed in para. 27 and 28 before being assembled to the pump. The complete pump must be tested in accordance with the schedule of pump tests detailed in para. 29-34. Where a unit fails to meet the test requirements, reference should be made to Table 4. Unless otherwise stated, tests are to be carried out at 200V, 3 phase, 400 c/s.

Test equipment

26. The pump can be tested on the rig shown diagrammatically in Fig. 7 using a 38 parts water-to-62 parts glycol mixture maintained at 15 - 25 deg. C (59 - 77 deg. F.) The specific gravity of the mixture should be 1.07 - 1.08 at 15.5 deg. C (59.9 deg. F.).

Schedule of motor tests

Insulation resistance test

27. Using a 500 volt insulation resistance tester, check that the insulation resistance between the motor leads and the motor frame is not less than 0.5 megohm.

Checking the motor speed and direction of rotation.

28. (1) Connect the 3 phase supply to the motor leads, Red (A) to lead number 1, Yellow (B) to lead number 2 and Blue (C) to lead number 3.

(2) Momentarily energize the motor and check that the motor starts immediately and runs anti-clockwise when viewed on the lower bearing housing end.

Note . . .

If the direction of rotation is incorrect, transfer the motor connection to obtain correct rotation and transfer the lead identification sleeves to the correct leads.

(3) Using the calibrated fan, SPE23119, or a suitable dynamometer, apply a torque of 10 oz. in. to the motor and run the motor under load. Check that, at normal running temperature, the motor speed is 5,800-5,900 rev/min, with a maximum power input of 130 watts and a maximum current consumption of 0.75 amp.

(4) Stop the motor and, using a 500 volt insulation resistance tester, check that the insulation resistance between the leads and the motor frame is not less than 0.5 megohm.

Note . . .

This test must be carried out immediately on completion of the motor speed run.

RESTRICTED

Schedule of pump tests

Note . . .

The current consumption and power input must be checked frequently throughout the tests and must not exceed 0.75 amp and 130 watts respectively. The tests must be carried out in the order given.

Insulation resistance test

29. Using a 500 volt insulation resistance tester, check that the insulation resistance between the electrical connection pins and the frame is not less than 0.5 megohm.

Gland leakage test

30. With the pump fully primed and a 12 inch head of fluid at the pump inlet proceed as follows:—

- (1) Apply an air pressure of 30 lb/in² to the test rig tank and close the rig flow regulator valve.
- (2) Run the pump for 15 minutes and check for
 - (a) External leakage of fluid—none permissible
 - (b) Gland leakage—2 drops per minute maximum
- (3) Stop the pump and check that any gland leakage does not exceed 1 drop per minute.

Starting test

31. With the flow regulator valve open and the pump fully primed with fluid, apply an input of 180V 380 c.p.s. to the motor. The pump must start satisfactorily. Repeat the test 10 times.

Dry running test

32. Mount the pump clear of fluid and run it dry for 5 minutes. Check that the current consumption and input power do not exceed the specified figures.

Endurance test

33. (1) With a 6 inch head of fluid at the pump inlet, run the pump at 10 lb/in.² delivery pressure.

(2) Allow the pump to warm up, then record the delivery flow, current consumption and power input.

Note . . .

The flow should be not less than 300 gal/hr.

(3) Continue running the pump for 1 hour, then again record the delivery flow, current consumption and power input.

Note . . .

There must be no appreciable variation in performance throughout the test, other than during the initial warm-up period.

(4) Set the delivery pressure to 6 lb/in² and record the delivery flow, current consumption and power input.

Note . . .

The flow should be not less than 550 gal/hr.

(5) Repeat operation (3).

Insulation resistance test

34. Immediately on completion of the endurance test, check that the insulation resistance between the electrical connection pins and the frame is not less than 0.5 megohm using a 500 volt resistance tester.

Calibration test

35. (1) With a 6 inch head of fluid at the pump inlet and the test rig flow regulator valve closed, run the pump and check that the pump delivery does not exceed 19 lb/in².

(2) Adjust the delivery flow to 300 gal/hour and check that the delivery pressure does not exceed 10 lb/in².

(3) Adjust the delivery flow to 550 gal/hour and check that the delivery pressure is not less than 6 lb/in².

RESTRICTED

TABLE 4
Fault diagnosis

Fault	Possible cause	Rectification
Low insulation resistance	Damaged motor leads	Check motor lead insulation for signs of chafing and/or deterioration. Damaged leads may be taped.
	Damp or short circuited stator windings.	Oven dry the stator and re-check insulation resistance. If the fault persists, reject the assembly.
Failure to run	Faulty electrical supply Faulty connections	Rectify as necessary Dismantle and rectify as necessary.
	Weak field	Reject stator assembly.
Gland leakage excessive.	Damaged or badly seated seal faces	Dismantle and examine the bellows gland seal face and the thrower assembly carbon ring. Reject defective assemblies.
Current consumption excessive and/or high watts.	Impeller fouling	Dismantle and check impeller for signs of rubbing. If necessary renew anti-corrosive lacquer, re-fit impeller and adjust shimming as detailed.
	Faulty motor bearings	Check rotor for free rotation. If faulty, renew bearings.
Performance varies.	Faulty electrical supply	} Refer above
	Faulty internal connections	
	Impeller fouling	
	Faulty motor bearings	

~~RESTRICTED~~

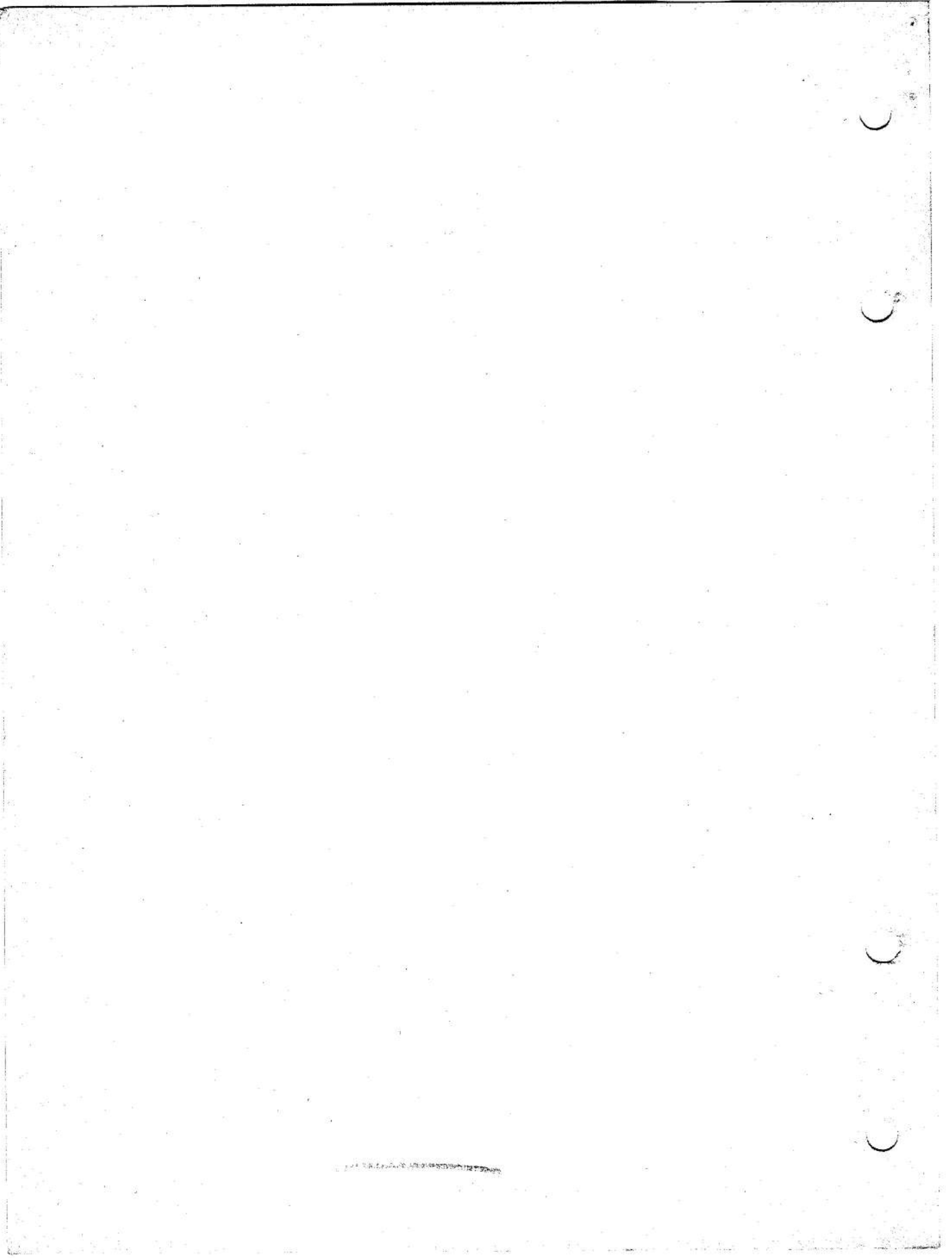

This file was downloaded from the RTFM Library.
Link: www.scottbouch.com/rtfm

Please see site for usage terms, and more aircraft documents.

