

Chapter 23

ACTUATOR, WESTERN, TYPE EJ 25, MK. 1C

LIST OF CONTENTS

	Para.		Para.
<i>Introduction</i>	1	<i>Reduction gears</i>	5
Dismantling, inspection, repair and re-assembly	2	Testing	
<i>End fittings</i>	3	<i>Actuator</i>	6
<i>Fixing centres, stroke and time of stroke</i> 4		<i>Motor</i>	7

LIST OF ILLUSTRATIONS

	Fig.		Fig.
<i>Fixed end-fitting</i>	1	<i>Moving end-fitting</i>	2

APPENDIX

	App.
<i>Schedule of fits, clearances and repair tolerances</i>	1

Introduction

1. This actuator differs from that described in A.P.4343, Vol. 1, Sect. 17, App. 7 on Western EJ 25 series, in respect of mounting, length of stroke and time of stroke at nominal load. Details of these variations are given in para. 4.

DISMANTLING, INSPECTION, REPAIR AND RE-ASSEMBLY

2. These are all described in A.P.4343, Vol. 6, Sect. 17, App. 7.

End fittings

3. This actuator is attached at the fixed end by a $\frac{3}{8}$ in. bolt which passes through two bushed lugs which are integral with the motor housing, whilst the moving end is attached by a $\frac{3}{8}$ in. bolt which passes through a self-aligning eye.

Fixing centres, stroke and time of stroke

4. The fixing centres, tolerances, stroke and time of stroke are as follows:—

(a) Extended centres 7.16 in. ± 0.02 in.

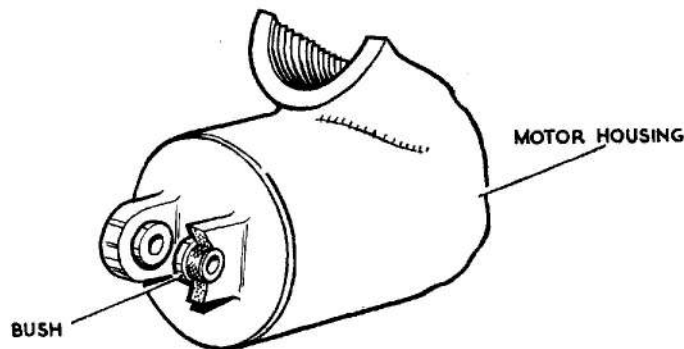

Fig. 1. Fixed end-fitting

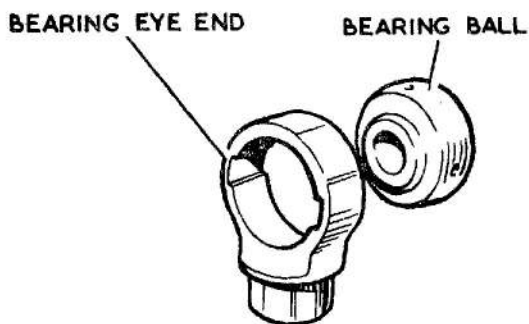

Fig. 2. Moving end-fitting

- (b) Contracted centres 6.16 in. ± 0.02 in.
- (c) Stroke 1.00 in.
- (d) Time of stroke at 28 volts and opposing load of 25 lb. is 3.5 seconds

Reduction gears

5. Three-stage epicyclic reduction gears are fitted, having a total reduction ratio of 78.6 : 1.

TESTING

Actuator

6. Load tests as follows are to be carried out on the actuator after repair and re-assembly.

(1) A running-in test consisting of approximately 10 runs in each direction, at 25 volts and with 25 lb. opposing load.

(2) A functional test should be performed by connecting the actuator to a 28 volt d.c. supply and applying loads of 0, 25, and 37 lb. The maximum current consumption and the time the piston takes to complete its 1.00 inch travel should not exceed the figures given below:—

Load (lb.)	Max. current (amp.)	Max. time (seconds)
0	0.80	3.43
25	1.00	3.875
37	1.10	4.00

Motor

7. Motor torque tests are described in A.P.4343, Vol. 6, Sect. 18.

SCHEDULE OF FITS, CLEARANCES AND REPAIR TOLERANCES

APPENDIX 1

All dimensions in inches

Actuator, Western, Type EJ 25, Mk. 1C

F.S./2

Item No. (1)	Description (2)	Dimension New (3)	Permissible Worn Dimension (4)	Clearance New (5)	Permissible Worn Clearance (6)	Remarks (7)
ACTUATOR						
1	Locating plate and piston housing, bore	0.875 nominal	—	0.0004 clear to 0.0005 interf.	0.0004	Bearings selected to give the fit quoted in Col. 5
2	Ballrace o/d					
3	Ballrace i/d	0.375 nominal	—	0.0005 clear to 0.0004 interf.	0.0005	Bearings selected to give the fit quoted in Col. 5
4	Land on worm, dia.					
5	Piston housing bush, bore	0.4375	0.4380	0.0010 0.0002	0.0015	
6	Piston o/d	0.4375	0.4365			
7	Guide slots in piston housing width	0.1875	0.1905	0.004 0.001	0.005	
8	Piston lugs, width	0.1875	0.1855			
9	Self aligning eye, spherical	0.495	—	—	As new	Ground to fit together with no perceptible backlash
10	Bearing ball	—	—	—	—	
11	Worm assembly, end float	—	—	0.0015	—	

A.P.4343D, Vol. 6, Sect. 14, Chap. 23, App. 1 (A.L. 66)

(A.L. 66, Nov. 58)

RESTRICTED

RESTRICTED

SCHEDULE OF FITS, CLEARANCES AND REPAIR TOLERANCES

APPENDIX 1 (continued)

All dimensions in inches

Actuator, Western, Type EJ 25, Mk. 1C

Item No. (1)	Description (2)	Dimension New (3)	Permissible Worn Dimension (4)	Clearance New (5)	Permissible Worn Clearance (6)	Remarks (7)
12	ACTUATOR Worm and piston thread	—	—	—	—	Maximum end float 0.001
13	MOTOR End cap solenoid core, i/d	0.5175 nominal	—	0.0005 clear to 0.0005 interf.	0.0005	Bearings selected to give the fit quoted in Col. 5
14	Ballrace sealing cup, o/d	—	—	—	—	
15	Ballrace i/d	0.1875 nominal	—	0.0001 interf. to 0.0004 Interf.	As new	Bearings selected to give the interference fit quoted in Col. 5
16	Armature and driving shafts, dia.	—	—	—	—	
17	Brush length	0.30	0.20	—	—	

This file was downloaded from the RTFM Library.
Link: www.scottbouch.com/rtfm

Please see site for usage terms, and more aircraft documents.

