

Chapter 62

ACTUATOR, WESTERN, TYPE UA2253

LIST OF CONTENTS

	<i>Para.</i>		<i>Para.</i>
<i>Introduction</i>	1	Assembly	
Dismantling	5	<i>Motor unit</i>	18
<i>Terminal block cover and electrical connection</i>	6	<i>Piston unit (piston and worm)</i>	19
<i>Motor, gearbox and piston units</i>	7	<i>Piston unit (limit switches)</i>	20
<i>Piston unit (limit switches)</i>	8	<i>Gearbox unit</i>	21
<i>Piston unit (piston and worm)</i>	9	<i>Motor, gearbox and piston units</i>	22
<i>Gearbox unit</i>	10	<i>Terminal block cover and electrical connections</i>	23
<i>Motor unit (motor and pinion)</i>	11	<i>Final assembly and switch setting</i>	24
<i>Motor unit (solenoid brake)</i>	12	Testing	
<i>Motor unit (brushes)</i>	13	<i>Test rig</i>	25
<i>Motor unit (armature and ballraces)</i>	14	<i>Actuator tests</i>	26
<i>Motor unit (brake solenoid and brushgear)</i>	15	<i>Motor tests</i>	27
<i>Motor unit (field coil assembly)</i>	16	<i>Insulation resistance after installation in aircraft</i>	28
Inspection and repair	17		

LIST OF TABLES

	<i>Table</i>
<i>Faults, causes and remedies</i>	1

LIST OF ILLUSTRATIONS

	<i>Fig.</i>		<i>Fig.</i>
<i>Terminal block cover</i>	1	<i>Motor unit</i>	4
<i>Piston unit</i>	2	<i>Trunnion</i>	5
<i>Gearbox unit</i>	3		

LIST OF APPENDICES

<i>Schedule of fits, clearances and repair tolerances</i>	1
--	---

Introduction

1. The linear actuator, Western, Type UA2253, has a normal working load of 165 lb. with a maximum of 250 lb.

2. The actuator incorporates a split field, series wound, reversible fractional horse power motor (normally operating from a 28-volt d.c. supply) which drives the piston through a gear reduction train and lead screw.

3. The piston stroke length is controlled

F.S./1

by four snap action limit switches mounted in pairs at each end of the piston housing. Each pair comprises a primary and an emergency switch, the emergency switch only becoming operative if the primary switch fails. There is also a mid-position switch to provide remote indication of the datum trim position.

4. The motor, with its integral electromagnetic brake, is a complete replaceable unit.

RESTRICTED

DISMANTLING

5. After the actuator has been removed from the aircraft and before commencing dismantling, connect the electrical lead to a 28-volt d.c. supply and run the actuator to the approximate centre of its stroke. Disconnect the electrical supply and proceed to dismantle as follows:—

Terminal block cover and electrical connection

6. The terminal block cover should first be removed in the following sequence:—

- (1) Unscrew the cable nut, withdraw the compression ring and sealing ring, take out four ch.hd. screws which connect the terminal block cover to the gearbox unit and slide the cover over the electrical lead sufficiently to obtain access to the terminals.
- (2) Detach all wires from the terminals, remove the terminal block cover and retain the rubber gasket.

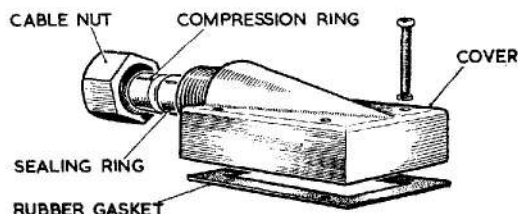

Fig. 1. Terminal block cover

Motor, gearbox and piston units

7. These three main units should then be separated from each other in the following manner:—

- (1) Unscrew the stiffnuts from the four through bolts which connect the three units and withdraw the bolts.
- (2) The piston unit may be pulled away from the gearbox unit, drawing the electrical leads clear of the terminal block terminals and retaining the gasket for re-assembly.
- (3) The motor unit can be pulled away from the gearbox unit and the gasket removed and retained. The trunnion may be detached from the motor unit cover, if necessary, after removing four bolts and washers. The trunnion gasket to be retained for re-assembly.

Piston unit (limit switches)

8. Dismantling of the limit switches and

the mid-position switch may now be proceeded with.

- (1) Take out three ch.hd. screws which hold the end plate to the ring plate and remove the end plate and the cover.
- (2) Take out two csk.hd. screws (which have been locked by peening) which attach the ring plate to the piston housing and remove the ring plate.
- (3) The two trip rods, complete with contact arm assemblies, springs and operating lugs, can now be lifted out and should not be further dismantled unless repairs or renewals are required.
- (4) Take the nuts and washers from the studs which attach the two mid-position contact block assemblies to the switch mounting blocks and remove the assemblies.
- (5) Take out the ch.hd. screws which hold the four limit switches to the mounting blocks and remove the limit switches.
- (6) Take out the csk.hd. screw and remove the spring contact and trip mounting block from the piston.

Piston unit (piston and worm)

9. The piston and worm assembly should next be dismantled.

- (1) Take out two csk.hd. screws which hold the bearing housing to the piston housing and separate the bearing housing (complete with ballrace, piston, worm, washers and ring nuts) from the piston housing. The gasket between the two housings to be retained for re-assembly.
- (2) Unscrew the worm from the piston.
- (3) If it is necessary to remove the ballrace from the worm, proceed as follows:—
 - (a) Remove the locking pin from the bearing housing and outer ring nut, and unscrew the ring nut from the bearing housing.
 - (b) Withdraw the worm assembly (consisting of worm, ballrace, washer, lock washer and inner ring nut) from the bearing housing.
 - (c) Bend down the lock washer, unscrew the inner ring nut and remove both washers and the ballrace from the worm.
- (4) If the ballrace only requires inspection and cleaning, remove the outer ring nut and its locking pin and withdraw the worm assembly as in (a) and (b) above.

RESTRICTED

Gearbox unit

10. The gearbox unit should be dismantled as follows:—

- (1) Take off the external circlip and outer retaining washer from the coupling end of the final carrier, and draw the complete gear assembly out of the annulus from the opposite end.
- (2) Take off the 'E' clip and shim washers from the final carrier shaft. The shims restrict gearbox end float and their positions should be noted for re-assembly.
- (3) Remove the gear carriers in their sequence, taking care to retain the planets on their respective pins.
- (4) Planet gears on 1st stage carrier can be removed after taking off the 'E' clips and shim washers. These shims restrict end float of 1st stage and their positions should be noted for re-assembly.

Note . . .

All other planets are free on the carriers.

- (5) Remove the internal circlip and inner retaining washer from the gearbox.
- (6) The annulus may be removed from the gearbox if necessary, after taking out the locating screw.
- (7) The terminal block may be removed from the gearbox, if necessary, by taking out two csk.hd. screws and lifting out the block and the varnished glass tape.

Motor unit (motor and pinion)

11. The motor and pinion should now be removed as follows:—

- (1) Take out the two csk.hd. screws which hold the motor end cap to the motor housing.
- (2) Withdraw the motor (complete with end cap and pinion) out of the housing.
- (3) Drive out the parallel pin and remove the pinion from the armature spindle.

Motor unit (solenoid brake)

12. The solenoid brake should next be dismantled:—

- (1) Take off the lock nut and spring washer which hold the brake disc in position.
- (2) Unscrew the brake disc (left-hand thread) from the armature spindle.

F.S./2

- (3) Pull off the brake shoe, bush, spindle bush and brake spring from the armature spindle.

Motor unit (brushes)

13. The brushes should now be removed as follows:—

- (1) Take out the screws.
- (2) Raise the springs, taking care not to strain them.
- (3) Mark the brushes and withdraw them from their holders.

Motor unit (armature and ballraces)

14. The armature and ballraces may now be taken out:—

- (1) Unscrew the two barrel nuts from the tie rods.
- (2) Extract the armature with end cap and both ballraces attached.
- (3) Remove the circlip and shims from the drive end of the armature spindle.
- (4) Withdraw the spindle from the end cap ballrace and push the ballrace out of the end cap, care being taken to retain the 'O' ring.
- (5) The ballrace at the commutator end may now be pulled off the armature spindle.

Motor unit (brake solenoid and brushgear)

15. The brake solenoid and brushgear should now be removed:—

- (1) Tap the tie rods with a plastic or hide hammer and withdraw the solenoid and brush mounting.
- (2) Unscrew the tie rods and remove the brushgear mounting from the solenoid casing, care being taken to retain the 'O' ring.

Motor unit (field coil assembly)

16. The field coil assembly should be tested in situ. If it proves defective, remove as follows:—

- (1) Remove all wires from the brushbox end of the windings and close the tags down on the fields.
- (2) Take out the grub screws which locate the field assembly in position and remove the field coils.

RESTRICTED

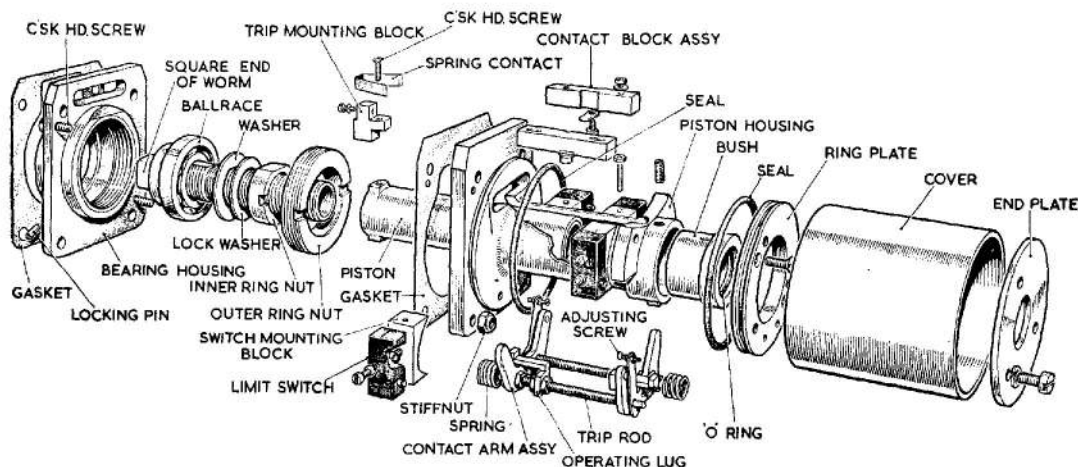

Fig. 2. Piston unit

INSPECTION AND REPAIR

17. The faults, causes and remedies table which follows, indicates the nature of the failure causes and is a guide to the inspection and repair required.

(1) Wash all mechanical parts in lead-free gasoline or white spirit until all traces of dirt and stickiness have disappeared.

(2) Measure parts for tolerances, etc., in accordance with Schedule of fits,

clearances and repair tolerances given in Appendix 1.

(3) Examine gears carefully for signs of burrs or grooving. Burrs may be removed with a fine carborundum stone but chipped or grooved gears must be renewed.

(4) Check that all 'O' rings are not damaged.

(5) Information on Inspection and repair of motors is contained in A.P.4343, Vol. 1 and Vol. 6, Sect. 18, App. 1.

Table 1

Faults, causes and remedies

Fault	Possible cause	Remedy
Actuator fails to start	Open circuit	} Renew limit switch
	Limit switch not making	
	Seizure Mechanical failure	} Trace fault and correct } Renew and damaged parts
	Breakage	} Indicated by motor running but output not operating. Strip and examine, renew broken parts
Actuator operates slowly or lacks power	Defective motor	} Check motor; } see last item in Table
	Excessive friction in actuator	
	Loose connection or faulty switch	} Trace and correct, or renew switch

For motor faults, causes and remedies see A.P.4343, Vol. 1, Sect. 18, App. 1

RESTRICTED

ASSEMBLY

Motor unit

18. After completing the inspection and repair of motor and pinion it should be re-assembled in the reverse order from that used for dismantling, but the following special points should be noted:—

- (1) Adjust the brush pressure before assembling the brushgear to the motor. This, measured on a former of 0.52 in. diameter, should be between 1.3 oz. and 1.7 oz. This is achieved by unscrewing the brush spring adjuster locking nuts several turns, gripping the head of the bolts with tweezers, pulling out of the slots and rotating in the direction required to adjust the spring tension.
- (2) Re-assemble all screws applying Ref. No. 33B/937 varnish.
- (3) Draw the rubber sleeves over the tie rod nuts right up to the face of the brush box plate, after the the rods are screwed home.
- (4) Replace shims in end cap to maintain armature end float of 0.002 in. to 0.004 in., including end float in ballraces.
- (5) Make sure that 'O' rings are correctly fitted.
- (6) Replace spindle bush to maintain brake gap of 0.008 in. to 0.015 in.
- (7) Ensure that end cap and brake solenoid locate on their respect spigots and keys.
- (8) Return the brushes to their holders only when the motor is fully assembled.

Piston unit (piston and worm)

19. On completion of inspection and repair, the piston and worm are to be re-assembled as follows:—

- (1) If the ballrace has been removed from the worm, replace it in the following sequence:—
 - (a) Ensure that ballrace locates against shoulder of worm.
 - (b) Fit washer, lock washer and inner ring nut.
 - (c) Secure lock washer against the flat provided on the ring nut.
 - (d) Return the above assembly into the bearing housing and fit the outer ring nut and locking pin.

Note . . .

Locking pin must not exceed 3/64 in. diameter.

- (2) If the ballrace has not been removed from the worm, return the worm assembly (consisting of worm, ballrace, washer, lock washer and inner ring nut) into the bearing housing and refit the outer ring nut and locking pin as in (d) above.
- (3) After checking that the 'O' ring fits correctly in the piston bush, and that the piston slides smoothly over its full length in the piston housing, screw the piston on to the worm.
- (4) Join the piston housing to the bearing housing, with gasket between, and connect by two csk.hd. screws.
- (5) Check that piston runs smoothly by rotating square end of worm.

Note . . .

Ballrace and worm to be greased with XG-275 grease.

Piston unit (limit switches)

20. The limit switches and mid-position switch may now be replaced in the piston unit as under:—

- (1) If the trip rod assemblies have been dismantled, they should now be re-assembled complete with contact arm assemblies, springs and operating lugs.
- (2) Engage the assembled trip rods in the holes provided in the piston housing, ensuring that the springs are fitted over the guide ferrules of their appropriate trip rods.
- (3) Fit the ring plate to the piston housing and fasten with two csk.hd. screws. The trip rods also engage in two holes provided in the ring plate.
- (4) Replace the trip block mounting and the spring contact, connecting same to piston by csk.hd. screw.
- (5) Refit the four limit switches to the switch mounting blocks, using ch.hd. screws to fasten.
- (6) Replace the mid-position contact assemblies on the studs of the switch mounting blocks and fasten with nuts and washers.
- (7) Re-connect wire leads.

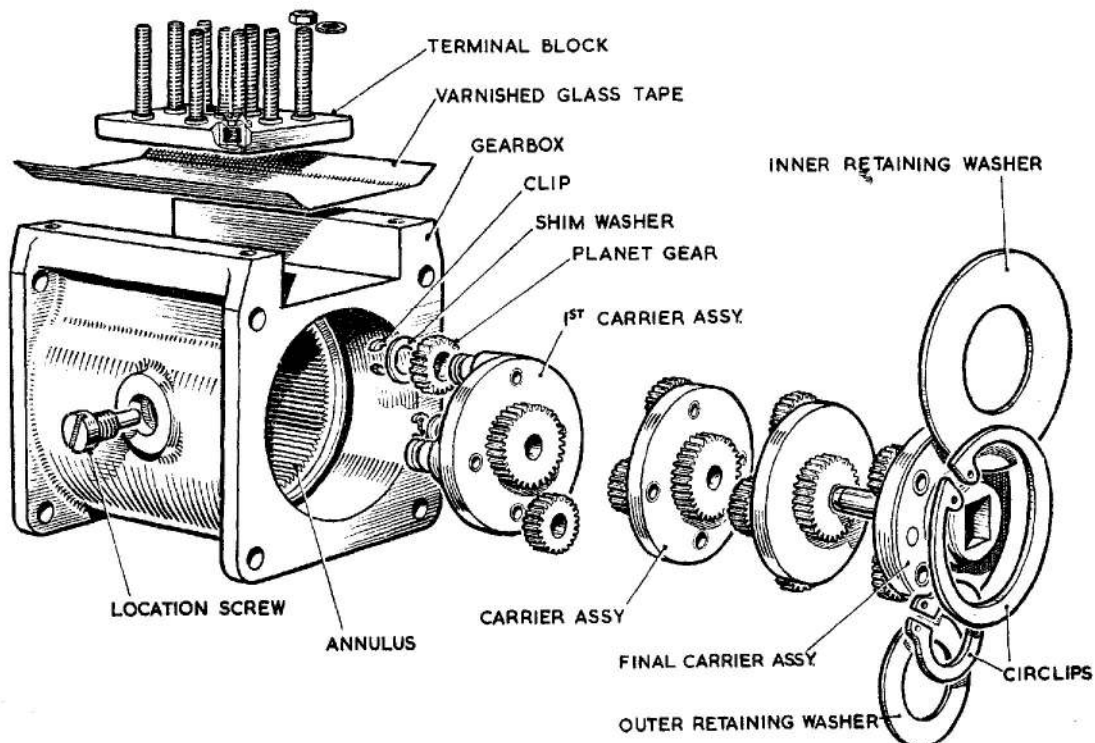

Fig. 3. Gearbox unit

(8) Ensure that the clearance between the end of the trip rod and the piston housing is 0.03 in. to 0.05 in. with spring expanded and switches made.

(9) For final adjustment of switches see para. 24, Final assembly and switch setting.

Gearbox unit

21. The gearbox should be assembled in the following order:—

(1) If the annulus has been removed from the gearbox, it should now be returned after the internal circlip and inner retaining washer have been fitted in the gearbox.

(2) Grease all planet gears with XG-275 grease.

(3) Insert final carrier and coupling assembly into the annulus and fit the external circlip and outer retaining washer.

(4) Drop four planet gears on to pins of final carrier.

(5) Insert the next carrier and ensure that its sun gear engages with the planets previously fitted.

(6) Repeat until all carriers and planets have been assembled in the annulus.

(7) Assemble shim washers at end of final carrier shaft to restrict gearbox end float and replace 'E' clip.

(8) The planets of the 1st stage are held in place by 'E' clips which should now be replaced together with the planet washers which restrict the 1st stage end float.

Note . . .

The maximum end floats are stated in Appendix 1.

Motor, gearbox and piston units

22. The three main units, having been re-assembled and the motor having been tested in accordance with para. 27, (Motor tests) should now be connected as follows:—

(1) Offer up the piston unit to the gearbox unit, with gasket between the two units, and engage the square end of the worm into the square hole of the final carrier and coupling.

Note . . .

The piston unit cover and end plate should be left off pending final setting of switches. See para. 24.

RESTRICTED

RESTRICTED

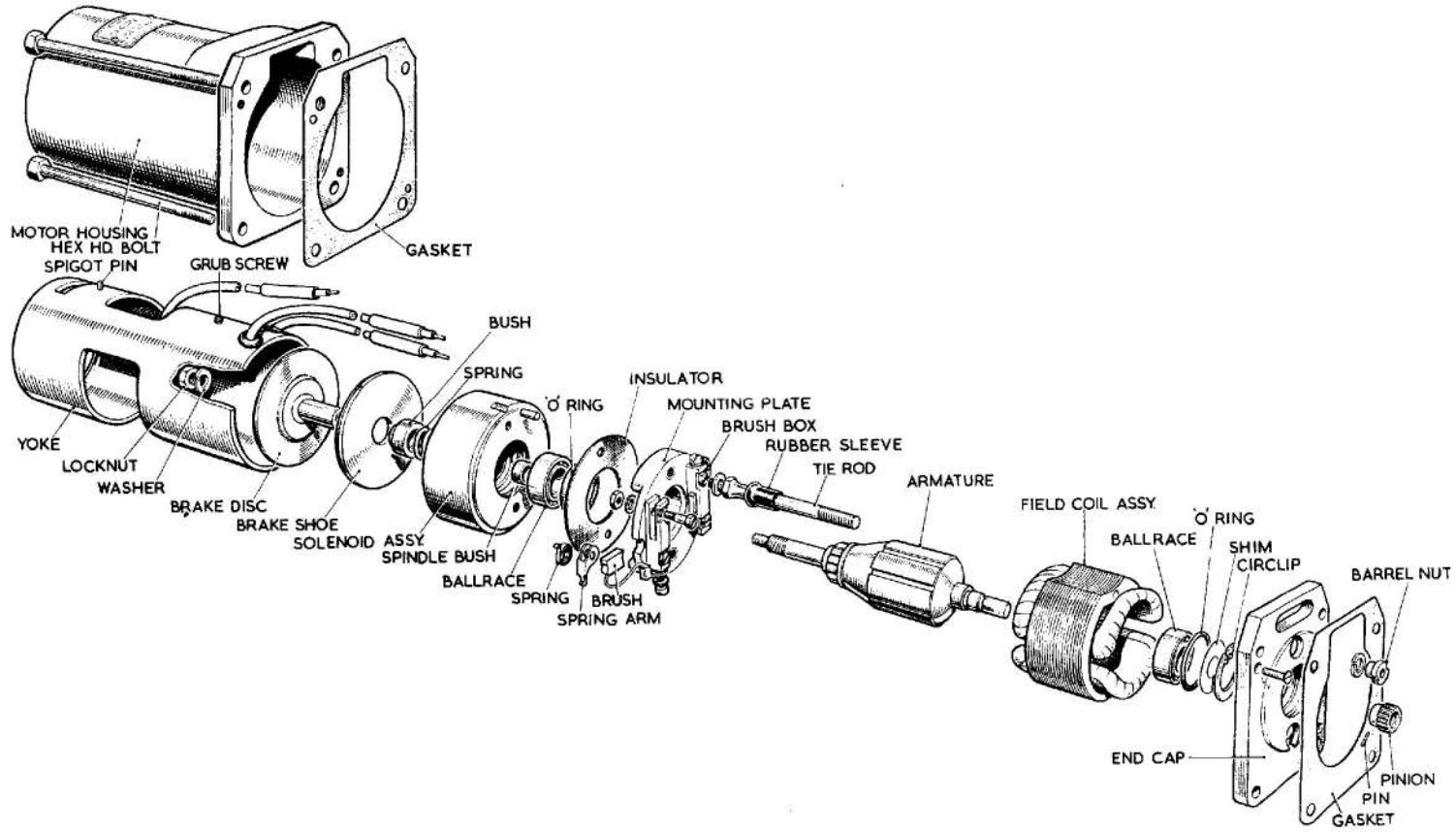

Fig. 4. Motor unit

(2) The motor unit should be offered up to the other end of the gearbox unit, with gasket between, and the pinion engaged with the planet gears of the first carrier.

(3) Insert the four through bolts which connect the three main units, and screw on the four stiffnuts.

Terminal block cover and electrical connection

23. The terminal block cover may now be fitted and the electrical connections made:—

(1) Pass the electrical cable through the entry of the terminal block cover, with the cable nut, compression ring and sealing ring threaded on the cable.

(2) Attach the wire leads to the terminals in accordance with circuit diagram in A.P.4343D, Vol. 1, Book 3, Sect. 14, Chap. 62.

(3) Replace the sealing ring.

(4) Replace the terminal block cover and rubber gasket, securing to the gearbox with four ch.hd. screws.

(5) Tighten the cable nut so that the compression ring grips the cable.

Final assembly and switch setting

24. The actuator can now be finally assembled and, if necessary, the switch settings adjusted.

(1) Replace the fixed end trunnion and gasket, and connect to motor unit with four bolts and washers.

(2) Ensure that the correct field lead from the motor is connected to the correct terminal by selecting the common lead (negative) from the motor and energizing each switch in turn, inching the motor as the switch is approached.

(3) Mount the actuator so that the fully extended and contracted centres can be accurately measured.

(4) Operate the actuator over the full stroke of 0.44 in. at 28 volts d.c. and an opposing load of 165 lb.

(5) Set the main limit switches and the mid-position switch to operate within the limits shown under Leading Particulars in A.P.4343D, Vol. 1, Book 3, Sect. 14, Chap. 62. A gap of 0.02 in. ± 0.002 in. to be maintained between main and emergency switches, both inboard and outboard.

(6) Replace piston unit cover, taking

care that the rubber seals remain in position in their respective recesses.

(7) Replace piston unit end plate and connect to the ring plate by three ch.hd. screws and lock washers.

TESTING

Test rig

25. Information on the test rig for actuators is contained in A.P.4343S of this series.

Actuator tests

26. Load tests as follows are to be carried out on the actuator after repair and re-assembly:—

(1) A functional test to be performed by connecting the actuator to a 28-volt d.c. supply and applying opposing loads of zero, 165 and 250 lb. The maximum current consumption and the time the piston takes to complete its 0.44 in. travel should not exceed the figures stated below:—

Load (lb.)	Max current (amp.)	Max. time (sec.)
0	2.05	5.6
165	2.45	7.0
250	2.65	7.4

Motor tests

27. Before the motor unit is returned to the actuator, the following checks and tests are to be carried out on the motor:—

(1) Ensure that the winding resistances are between the following limits:—

Armature, between adjacent segments	0.94 to 1.35 ohms
Armature, across segments	4.15 to 4.80 „
Field coil	1.05 to 1.15 „
Brake coil	23.00 to 26.00 „

(2) Check that brush pressure is between 1.3 and 1.7 oz.

(3) Ensure that brushes bed down satisfactorily over the whole circumferential width and at least 80 per cent of the area.

(4) Check for correct rotation as follows, when connected to a source of supply and when viewed on pinion end.

(a) A and H = Clockwise

(b) A and G = Anticlockwise

(5) Operate five or six times in each direction on no load, to ensure that brake shoe pulls off satisfactorily to allow the armature to rotate freely at a maximum terminal voltage of 18 volts.

RESTRICTED

(6) Apply a torque of 1.0 oz. in. at a terminal voltage of 28 volts $\pm \frac{1}{2}$ volt, when the speed in each direction must not be less than 14,500 r.p.m. and the current consumption must not exceed 2.2 amperes.

(7) Test for armature over-run by running the motor unloaded at 28 volts and measuring the over-run after switching off. Repeat five times in each direction, when the reading must not exceed fifteen revolutions of the armature.

(8) Subject the motor to a flash test of 500 volts r.m.s. at 50 c/s a.c. between live parts and the frame for a period of one minute while the motor is still warm after a 15 seconds run in each direction on no load at 25 volts.

(9) Carry out a subsequent insulation resistance test of 500 volts after a further 15 seconds run in each direction, when the reading must not be less than 2 megohms.

(10) Test the motor for endurance with 50 starts and 50 stops in each direction with a terminal voltage of 18 volts and the motor running light. This test to be spread over a period of 25 minutes, allowing a maximum running period of 5 seconds followed by a rest period of 10 seconds. Upon completion of this test, re-check for armature over-run.

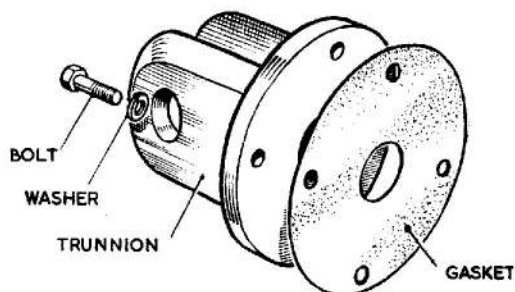

Fig. 5. Trunnion

(11) Check that all nuts and screws are properly locked.

(12) The tests scheduled above are to be carried out at a room temperature of 15 deg. C.

Insulation resistance after installation in aircraft

28. Using a 250-volt insulation resistance tester, measure the insulation resistance between live parts and the frame. The reading must not be less than 2 megohms.

29. Due to the humidity prevalent in aircraft and at dispersal points, the minimum permissible insulation resistance shall be 50,000 ohms.

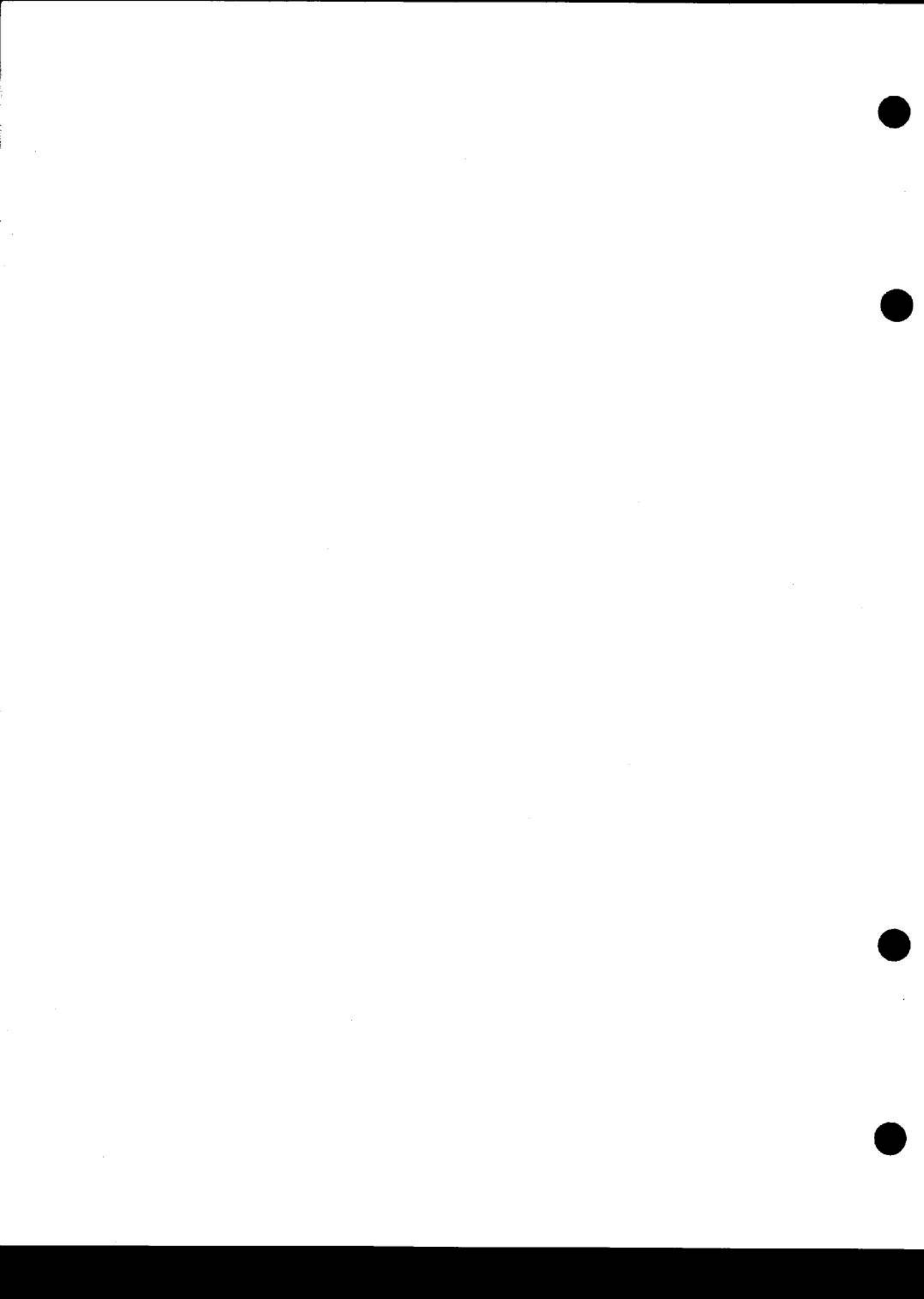

SCHEDULE OF FITS, CLEARANCES AND REPAIR TOLERANCES

APPENDIX 1

All dimensions in inches

Item No.	Description	Dimension New	Permissible Worn Dimension	Clearance New	Permissible Worn Clearance	Remarks
(1)	(2)	(3)	(4)	(5)	(6)	(7)
PISTON UNIT						
1	Bearing housing bore	1.125	—	0.0015	0.0015	
2	Ballrace	o/d nominal	—	0.0002		
3	Ballrace	i/d 0.500 nominal	—	0.0005 clear to 0.0004 interf.	0.0005	Bearing selected to give the fits quoted in Col. 5
4	Worm land dia.					
5	Piston housing bore	0.630	0.633	0.004	0.006	
6	Piston	o/d 0.630	0.627	0.002		
7	Guide slots in piston housing, width	0.250	0.255	0.004	0.007	
8	Piston lugs, width	0.250	0.248	0.001		
GEARBOX UNIT						
9	1st stage gear assy.	—	—	—	—	Maximum end float 0.005
10	Complete gear assy.	—	—	—	—	Maximum end float 0.012

RESTRICTED

SCHEDULE OF FITS, CLEARANCES AND REPAIR TOLERANCES

APPENDIX 1 (continued)

All dimensions in inches

Item No.	Description	Dimension New (3)	Permissible Worn Dimension (4)	Clearance New (5)	Permissible Worn Clearance (6)	Remarks (7)
MOTOR UNIT						
11	Solenoid core bore	0.500 nominal	—	0.0013	0.0013	
12	Shielded ballrace o/d					
13	Shielded ballrace i/d	0.1875 nominal	—	0.0004 clear to 0.0002 interf.	0.0004	Bearing selected to give the fits quoted in Col. 5
14	Armature spindle, commutator end	—	—	—	—	
15	End cap bore	0.500 nominal	—	0.0013 0	0.0013	
16	Shielded ballrace o/d					
17	Shielded ballrace i/d	0.1875 nominal	—	0 to 0.0004 interf.	as new	Bearing selected to give the interference fit quoted in Col. 5
18	Armature spindle, drive end					
19	Brush length	0.30	0.20	—	—	

RESTRICTED

This file was downloaded
from the RTFM Library.
Link: www.scottbouch.com/rtfm
Please see site for usage terms,
and more aircraft documents.

