

Chapter 93

ACTUATOR, PLESSEY, TYPE 1CZ 80383/1

LIST OF CONTENTS

	<i>Para.</i>		<i>Para.</i>
<i>Introduction</i>	1	Reconditioning (motors)	
Reconditioning (actuator)		<i>Tools and test equipment (motors)</i>	27
<i>Tools and test equipment (actuator)</i>	3	Dismantling	28
Dismantling	5	Inspection and repair	29
Inspection and repair	6	<i>Soldered joints</i>	30
<i>Lubrication</i>	8	<i>Brake housing</i>	31
<i>Application of lacquer</i>	10	<i>Yoke</i>	39
<i>Locking</i>	11	<i>Brushgear</i>	41
<i>Gaskets</i>	12	<i>Armature</i>	42
Assembling	13	<i>Insulation resistance</i>	45
Testing		<i>Bearings</i>	46
<i>Actuator</i>	14	Assembling	48
<i>Initial stroke setting</i>	15	Testing	
<i>Endurance tests</i>	18	<i>Motors</i>	49
<i>Insulation resistance test</i>	19	<i>Direction of rotation</i>	50
<i>High voltage flash test</i>	20	<i>Running in</i>	51
<i>Performance tests</i>	21	<i>Brake air gap</i>	52
<i>Stroke variation check</i>	23	<i>Speed balance</i>	53
<i>Final stroke setting</i>	24	<i>Torque test</i>	54
<i>Insulation resistance test</i>	25	<i>Insulation resistance test</i>	57
		<i>Brake overrun test</i>	58
		<i>Re-check of brake air gap</i>	59

LIST OF TABLES

	<i>Table</i>		<i>Table</i>
<i>Special tools and test equipment (actuator)</i>	1	<i>Special tools and test equipment (motors)</i>	4
<i>Performance tests</i>	2	<i>Torque test</i>	5
<i>Stroke variation</i>	3		

LIST OF ILLUSTRATIONS

	<i>Fig.</i>		<i>Fig.</i>
<i>Exploded view of actuator</i>	1	<i>Actuator wiring</i>	4
<i>Reduction gear trains</i>	2	<i>Exploded view of motor</i>	5
<i>Mains bearing shimming</i>	3	<i>Fits and clearances diagram</i>	6

APPENDIX

	<i>App.</i>
<i>Schedule of fits, clearances and repair tolerances</i>	1

Introduction

1. The Type 1CZ80383/1 (Twin-motor Jaguar) is an offset linear actuator with a plunger stroke of 3 in. and a normal working load of 80 lb. (max. 120 lb.).

2. The actuator incorporates two split-field, series-wound, fractional-horse-power motors (one main and the other auxiliary), either of which drives the plunger through spur and epicyclic reduction gear trains and a leadscrew. Each motor, with its integral electro-mechanical brake and pinion, is a complete, replaceable unit. In this chapter, the reconditioning procedure is given under two headings, viz. actuator, para. 3 to 26; motors, para. 27 to 59.

RECONDITIONING (ACTUATOR)

Tools and test equipment (actuator)

3. In addition to an ordinary tool kit, the special tools and test equipment listed in Table 1 are required for reconditioning the actuator.

4. In addition to the test equipment listed in Table 1, equipment is required for setting the stroke of the actuator and carrying out the load tests. Details of this equipment will be found in A.P.4343S, Vol. 1, Sect. 16, Chap. 3.

DISMANTLING

5. Dismantle the actuator in the following sequence:

(1) Slacken the locknut and remove the front eye end and locknut from the end of the plunger.

(2) Remove the four nuts, covers and bushes from the cable entry glands in the front of the outer cover.

(3) Remove the six small screws and plain washers (four in the upper section of the rear cover and two in the lower flange of the centre housing) which secure the outer cover flange to the forward face of the centre housing. Unscrew the captive screw at the front of the outer cover and withdraw the outer cover from the actuator.

(4) Remove the insulation material from between the motors. Disconnect the three leads from each limit switch and the two yellow leads from the terminals on the motors.

(5) Remove the two nuts (outside) and the two screws (inside) from each motor flange, and remove the two motors from the motor housing. Remove the grease shield from each motor aperture.

Table 1

Special tools and test equipment
(actuator)

Nomenclature	Part No.	Ref. No.
SPECIAL TOOLS		
Slotted spanner for ring nut on final drive gear	T353514	
Peg spanner for holding final drive gear when tightening nut	T328937	
Pliers for inserting drive pin	T353523	
Extractor for $\frac{3}{8}$ in. bearings	T335187	
Extractor for $\frac{1}{2}$ in. bearings	T335202	
Crimping pliers for terminal tags	CZ50125	
Jaws for crimping pliers	Z50102	
Crimping pliers for tag thimbles	T353214	
TEST EQUIPMENT		
Insulation resistance tester	TD2728	5G/152
Flash test set	TD2846	

RESTRICTED

(6) Remove the nuts, spring washers and special screws from each limit switch assembly, and remove the four limit switch assemblies from the plunger housing. The switch operating mechanisms can be dismantled by removing the split pin from the end of each rocker spindle.

(7) Remove the four nuts from the plunger housing flange and carefully withdraw the plunger housing from the centre housing and plunger. Remove and carefully retain the shims located between the plunger housing spigot and the main bearing.

(8) Withdraw the four bolts and plain washers from the lower section of the rear cover and remove the trunnion assembly. Remove the spacer from the leadscrew rear bearing aperture.

(9) Withdraw the four bolts and plain washers from the upper section of the rear cover.

(10) Remove the nut, spring washer, auxiliary drive gear and key from the front of the auxiliary drive shaft. Remove and carefully retain the shims located between the gear and the bearing.

(11) Withdraw the motor housing, complete with the sun gear shaft assembly, from the centre housing. Remove the nut, spring washer, main drive gear and key from the front of the sun gear shaft. Withdraw the sun gear shaft from the motor housing, and remove and carefully retain the shims located between the sun gear and the rear bearing. Remove the sun gear front bearing, retaining ring, spacer and rear bearing, and the auxiliary drive shaft bearing from the motor housing. If necessary, heat the housing and press out the bearings, applying pressure to their outer races, or use extractor T335202; in the latter case, the bearings must be renewed on assembly.

(12) Remove the rear cover from the centre housing. Remove the intermediate drive shaft from the centre housing and the bearings from the rear cover. If necessary, heat the rear cover and tap out the bearings, or use extractor T335187; in the latter case, the bearings must be renewed on assembly.

(13) Remove the small retaining ring and spacer from the rear end of the auxiliary drive shaft.

(14) Remove the four screws and spring washers which secure the annulus assembly to the centre housing. Hold the flanges of the annulus housing and its end cap tightly together, and carefully withdraw the complete annulus assembly, together with the auxiliary drive shaft mounted alongside, from the centre housing.

Note . . .

The utmost care must be taken when removing the annulus assembly, to avoid losing any of the 80 small ball bearings which support the annulus in the annulus housing and end cap.

(15) Place the annulus assembly in a small cardboard box and remove the end cap from the annulus housing. Remove and carefully retain the shims located between the flanges of these components.

(16) Support the planet gear assembly shaft and tap out the special dowel which secures the small gear to the rear end of the shaft; remove the gear. Remove the retaining ring from the middle of the shaft. Withdraw the planet gear assembly from the centre housing.

(17) Remove the retaining ring which secures the auxiliary drive shaft rear bearing in the centre housing, and remove this bearing together with the planet gear assembly shaft and intermediate drive shaft bearings. If necessary, heat the housing and press out the bearings, applying pressure to their outer races.

(18) Unscrew the plunger from the leadscrew.

(19) Remove the ring nut from the rear end of the leadscrew, using special spanners T328937 and T353514, and remove the final drive gear.

(20) Remove the leadscrew, complete with main bearing, from the centre housing. Remove the drive pin and main bearing from the leadscrew.

INSPECTION AND REPAIR

6. Wash all metal parts of the actuator in white spirit and remove all traces of grease and dirt. Clean, dry, compressed air should be used for drying the components, but when drying ball bearings by this method the bearing must not be rotated by the air

jet. The parts should then be laid out and examined carefully for signs of obvious damage such as distortion, burring and scoring. After this, the parts should be checked against the schedule of Fits, Clearances and Repair Tolerances (App. 1) and all worn parts renewed.

7. The following points must be given special attention:—

(1) Gears: The gear teeth must be examined for bruises, burrs or undue wear.

(2) Leadscrew, plunger and housing: Check the part of the leadscrew which supports the final drive gear. Check the linear backlash between the threads of the leadscrew and plunger (see App. 1). Examine the threads for scoring and other damage. Check the side play of the plunger in the front bush. Inspect the plunger ears for damage or wear.

(3) Annulus and planet gear assemblies: Check the planet gears for security of mounting on the carrier and for freedom of rotation. Inspect the ball bearings and tracks of the annulus assembly for pitting and cracks.

(4) Limit switches: The limit switches should be renewed at every alternate reconditioning period. Check each switch manually for correct operation with the switch connected to a 28-volt d.c. supply.

An ammeter should be in circuit and the current adjusted to 2 amp. Inspect for security of each switch on its mounting plate and for rigidity of terminal plugs.

(5) Wiring: Inspect the internal wiring for chafed, worn or broken leads.

Lubrication

8. Actuators are required to operate for a considerable period without inspection or maintenance. It is important, therefore, that lubrication be carried out with care. Use grease to DTD.844 (XG-278) for all applications. Lubrication is to be carried out progressively during reassembly. The parts of the actuator to be lubricated are:—

- (1) Gear teeth
- (2) Bearings
- (3) Leadscrew and plunger threads
- (4) Annulus and planet gear assemblies
- (5) Bushes; thrust and sliding faces.

9. The instructions set out below should be followed when lubricating the actuator. The stated amount of grease to be applied to the components must not be exceeded since over-lubrication can be as harmful as under-lubrication.

(1) The grease should be applied with a suitable tool. Brushes should not be used owing to the danger of bristles or hairs becoming detached and lodging in the mechanism.

(2) The grease is to be worked into the spaces between the gear teeth round the whole circumference of each gear.

(3) Both sides of each bearing are to have grease pressed into the space between the inner and outer races for a distance of one third of the circumference. If one side of a bearing is inaccessible, then two-thirds of the accessible side should be covered. The bearings should then be rotated to work the grease into the bearing.

(4) The spaces between the threads of the leadscrew should be filled with grease for a radial distance of one quarter of its circumference over the total length of the screw. The plunger should then be screwed on to the leadscrew to spread the

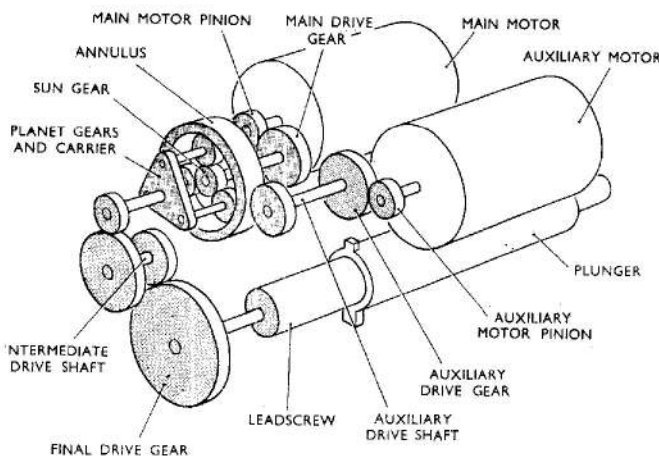

Fig. 2. Reduction gear trains

grease evenly around the screw. The excess grease removed by the plunger should then be wiped off.

(5) The gear teeth on the annulus should be lubricated as described in sub-para. (2) and grease should be applied to one third of the circumference of each ball track. The central hole in each planet gear stud should be packed with grease.

(6) Smear bushes, thrust and sliding faces with grease. For very small bushes, a leather swab may be used.

Application of lacquer

10. During reassembly of the actuator, certain components must be protected with lacquer as follows:—

(1) A mixture of Epihard lacquer 480/1 and Epihard accelerator 480/2 is to be used internally and externally. A quantity sufficient for one day's work should be mixed as follows:—

3 parts (by volume) lacquer 480/1

1 part (by volume) accelerator 480/2

(2) Internal use: Apply to screw heads, nuts, washers and terminal block moulding.

(3) External use: Apply to all unpainted metal surfaces, screw heads, nuts, washers and gasket edges.

Note . . .

Lacquer must not be applied to cables and sleeves, or over stoved finishes, to spigot faces, joint faces or parts normally lubricated. None must enter any bearing.

Locking

11. Lock all drilled head screws with 22 s.w.g. stainless steel locking wire. Fit new tabwashers at all points shown in the exploded view (*fig. 1*). All tabwashers must be locked with the tabs formed over the largest possible radius.

Gaskets

12. Before fitting gaskets, ensure that all traces of old gaskets have been removed and that the metal surfaces are cleaned and inspected. The new gaskets must be coated on both faces with Hermetite 1326B jointing compound and care must be taken that no dirt adheres to the surfaces of the gaskets after applying the compound. The gaskets should be left for ten minutes before making the joints. All excess compound must be cleaned off after assembly.

ASSEMBLING

13. When all parts have been thoroughly cleaned, and renewed where necessary, and when the motors have been reconditioned in accordance with the instructions in para. 27 to 59, the actuator is to be assembled in the following sequence:—

(1) Assemble the main bearing to the leadscrew, applying pressure to its inner race. Fit a new drive pin, using the pliers T353523; remove burrs.

(2) Heat the centre housing to approximately 100 deg. C. and insert the main bearing with leadscrew, ensuring that the bearing is pressed fully home in its aperture. While the centre housing is still hot, press the bearings for the front of the planet gear assembly shaft, the front of the intermediate shaft, and the rear of the auxiliary drive shaft into their respective apertures, applying pressure to their outer races. Secure the outer race of the auxiliary drive shaft bearing with a retaining ring.

(3) Assemble the final drive gear to the end of the leadscrew, aligning the slots in the hub with the drive pin. Fit the ring nut and new tabwasher. Hold the gear with the peg spanner T328937 and tighten the nut with the slotted spanner T353514; stag the tabwasher into the slots in the nut and the gear in two places.

(4) Screw the plunger on to the leadscrew until it reaches the central position.

(5) Assemble the planet gear assembly to the centre housing. Fit a new retaining ring to the middle of the shaft. Position the small gear on to the end of the shaft and, supporting the shaft, secure the gear with the groverlock dowel.

(6) Assemble the annulus assembly as follows. Place the annulus housing, mounting flange uppermost, on a bench and, after lightly greasing each of the 40 ball bearings, place them in position around the track. Place the remaining 40 ball bearings in position around the track of the annulus end cap, in a similar manner. Lubricate as described in para. 8. Position the shims on the joint face of the annulus end cap. Place the annulus in the annulus housing and, holding the annulus in position, reverse the annulus housing and place it in position on the end cap. Clamp the flanges together with screws and nuts, and check the annulus end float (*see App. 1*); remove the screws and nuts.

RESTRICTED

(7) Holding the flanges of the annulus housing and its end cap tightly together, place the annulus assembly in position over the planet gear assembly in the centre housing, at the same time inserting the auxiliary drive shaft into the housing and meshing the pinion with the external teeth on the annulus. Secure the annulus assembly with four screws and spring washers; the centre screw in the main section of the mounting flange is slightly shorter than the remaining three screws. Secure the rear end of the auxiliary drive shaft with a spacer and a new retaining ring.

(8) Heat the motor housing to approximately 100 deg. C. Assemble the rear bearing, a spacer, a retaining ring and the front bearing, in that order, to the sun gear shaft aperture, applying pressure to the outer races of the bearings. Press the front bearing of the auxiliary drive shaft into its aperture.

(9) Place the shims in position behind the sun gear and assemble the sun gear shaft to the motor housing. Fit a key, the main drive gear, a spring washer and nut to the front end of the shaft. Check the end float of the sun gear (see App. 1).

(10) Ensure that the dowels are in position in the centre housing. Assemble the motor housing to the centre housing, rotating the sun gear to mesh its teeth with those on the planet gears.

(11) Place the shims on the front end of the auxiliary drive shaft and fit a key, the auxiliary drive gear, a spring washer and a nut to the shaft. Check the clearance between the gear and the motor housing (see App. 1).

(12) Heat the rear cover to approximately 100 deg. C. and press the bearings for the rear of the planet gear assembly shaft, the rear of the intermediate drive shaft, and the rear of the leadscrew, into their respective apertures, applying pressure to their outer races.

(13) Fit the intermediate drive shaft in its bearing in the centre housing, meshing the teeth of the small gear with those on the final drive gear and the teeth of the large gear with those on the small gear on the end of the planet gear assembly shaft.

(14) Fit a new gasket, coated with compound (see para. 12), to the rear joint

face on the centre housing. Ensure that the dowels are in position in the centre housing and assemble the rear cover to the centre housing.

(15) Place the shims in position against the outer race of the main bearing. Ensure that the larger torque ear on the plunger is correctly positioned to contact the limit switch trips and assemble the plunger housing over the plunger and into position on the centre housing.

Note . . .

If new parts have been fitted, it will be necessary to check the main bearing shimming (fig. 3). Ensure that the bearing is pressed fully home in its aperture and add shims until a gap can be seen (against a source of light) between the centre and plunger housings when these are pressed together manually. Then remove only sufficient shims to permit this gap to be eliminated.

(16) Place a spacer in the leadscrew rear bearing aperture in the rear cover. Fit a new gasket, coated with compound (see para. 12), and the trunnion assembly to

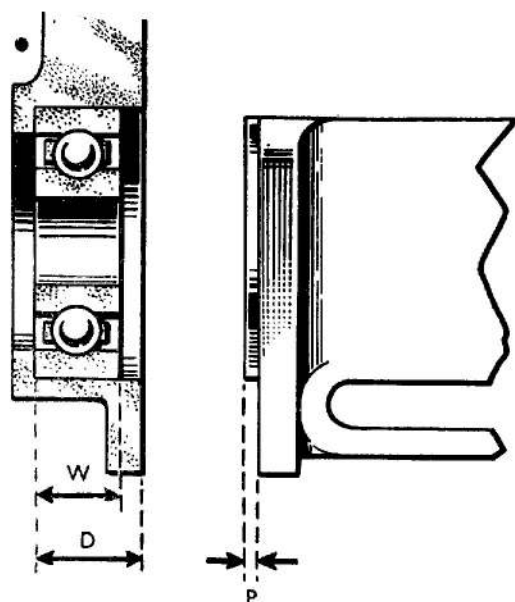

D - W - P = SHIM THICKNESS

Fig. 3. Main bearing shimming

the rear cover. Fit the four bolts and plain washers, securing them on the plunger housing flange with new tab-washers and nuts; lock the nuts with the tabs.

(17) Fit the four bolts and plain washers to the upper section of the rear cover. Place a grease shield in each motor aperture and assemble the main and auxiliary motors to the motor housing, ensuring that the flats on their mounting flanges are facing towards the plunger housing. Secure each motor with two screws and tab washers (inside) and two nuts and tabwashers (outside); lock the nuts and screws with the tabs.

(18) Assemble each limit switch operating mechanism on its rocker spindle and secure in position with a new split pin. Fit the limit switch assemblies to the sides of the plunger housing, securing each assembly with two special screws, spring washers and nuts; ensure that a special tabwasher is placed under the spring washer of the outer nut on each assembly. Leave the nuts finger-tight to allow for stroke setting at a later stage.

(19) Connect the electrical leads to the motors and the limit switches as shown in the wiring diagram in fig. 4. Fit the

insulation material between the motors, locating it on the screw of the auxiliary motor, tucking the excess material between the motors and securing it with thread.

Note . . .

The outer cover is fitted after the stroke setting has been carried out.

TESTING

Actuator

14. After reassembly, the actuator must be tested in accordance with the following tests. During the tests, the actuator must not be overheated; the rating of the motors on normal load is $1\frac{1}{2}$ minutes. The test equipment (see Table 1) must be available.

Initial stroke setting

15. With the special front eye end (Part No. CZ55524) fitted to the plunger and with the actuator mounted on the stroke setting rig, set the plunger stroke in the following manner:—

(1) Slacken the securing nuts on the limit switch assemblies and slide the switches outwards to the extreme extend or retract positions.

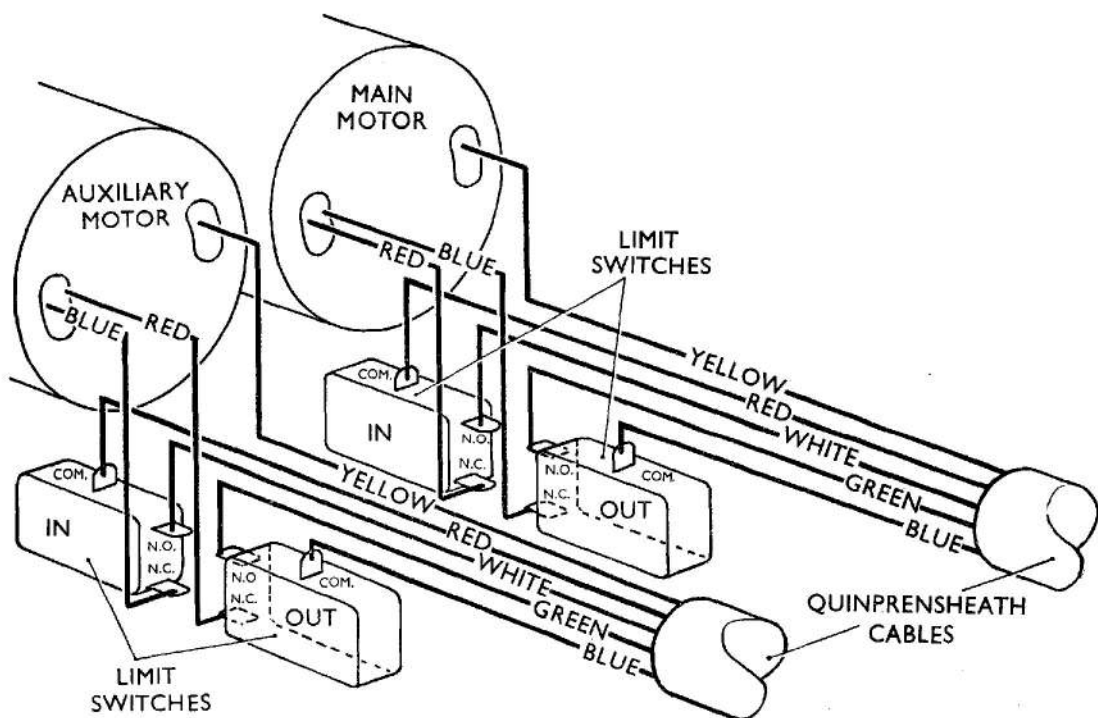

Fig. 4. Actuator wiring

RESTRICTED

(2) Slide both main motor limit switches inwards approximately $\frac{1}{8}$ in.

(3) Connect the main motor to a 28-volt d.c. supply and, by adjusting the position of the main motor limit switches, set the stroke, against a 5 lb. load, to the following dimensions:—

Retracted centres 3.50 in. ± 0.010 in.

Extended centres 6.50 in. ± 0.010 in.

(4) Tighten the limit switch securing nuts and disconnect the supply to the main motor.

(5) Slide both auxiliary motor limit switches inwards to a position approximately $\frac{1}{8}$ in. inside the main motor limit switch positions.

(6) Connect the auxiliary motor to a 28-volt d.c. supply and, by adjusting the position of the auxiliary motor limit switches, set the stroke, against a 5 lb. load, to the dimensions given in sub-para. (3).

(7) Tighten the limit switch securing nuts and disconnect the supply to the auxiliary motor.

16. Remove the actuator from the rig. Place a new oil seal in the recess in the outer cover and thread the quinquensheath cables through their respective holes in the cover. Assemble the outer cover, with its gasket left dry, to the actuator. Secure the cover with six small screws and plain washers at the rear and the large captive screw at the front. Slide a new rubber gland on to each cable and secure them in the outer cover with the bushes, covers and nuts.

17. Re-mount the actuator on the stroke setting rig and re-check the stroke settings with the main and auxiliary motors in turn.

Endurance tests

18. With the actuator mounted on the load test rig, carry out the following endurance tests:—

(1) Main motor. With the main motor connected to a 28-volt d.c. supply, carry out 40 full stroke cycles of operation against a load of 80 lb. The load must be compressive during 20 cycles and tensile for the remaining 20 cycles. The frequency of operation must not exceed 60 cycles per hour.

(2) Auxiliary motor. With the auxiliary motor connected to a 28-volt d.c. supply,

carry out 20 full stroke cycles of operation against a load of 80 lb. The load must be compressive during 10 cycles and tensile for the remaining 10 cycles. The frequency of operation must not exceed 60 cycles per hour.

Insulation resistance test

19. Immediately after the completion of each of the endurance tests, the insulation resistance between each connection and the frame must be measured with a 500-volt insulation resistance tester. The reading must not be less than 20 megohms.

High voltage flash test

20. The actuator must resist an alternating potential of 500 volts R.M.S., 50 c.p.s. for one minute. The insulation resistance must then be re-measured as described in para. 19.

Performance tests

21. With the actuator mounted on the load test rig, carry out the performance tests in accordance with Table 2.

22. The following abbreviations are used:

T.L.O. = Tensile load opposing

T.L.A. = Tensile load assisting

C.L.O. = Compressive load opposing

C.L.A. = Compressive load assisting

Stroke variation check

23. The deviations from the nominal settings must not exceed the figures given in Table 3. The plunger should travel continuously through its full stroke for each check.

Final stroke setting

24. Remove the outer cover from the actuator and fit the standard front eye end (Part No. Z63582) to the plunger. Mount the actuator on the stroke setting rig and set the plunger stroke, as described in para. 15, to the following dimensions:—

Retracted centres 3.89 in. $+0.000$
 -0.030

Extended centres 6.89 in. $+0.030$
 -0.000

Table 2

Performance tests

Applied voltage	Load (lb.)	Condition of load	Time (seconds) for 3 in. stroke		Maximum current (Amp.)
			Min.	Max.	
MAIN MOTOR					
29	0	EXTEND	2.60	3.20	1.6
29	0	RETRACT	2.60	3.20	1.6
29	80	C.L.O.	3.80	4.80	2.8
29	80	C.L.A.	2.75	3.45	2.0
29	80	T.L.O.	3.80	4.80	2.8
29	80	T.L.A.	2.75	3.45	2.0
29	120	C.L.O.	4.50	5.70	3.2
29	120	T.L.O.	4.50	5.70	3.2
22	0	EXTEND	3.20	4.00	1.5
22	0	RETRACT	3.20	4.00	1.5
22	80	C.L.O.	5.70	7.20	2.6
22	80	T.L.O.	5.70	7.20	2.6
22	120	C.L.O.	7.40	9.60	3.0
22	120	T.L.O.	7.40	9.60	3.0
AUXILIARY MOTOR					
29	0	EXTEND	2.80	3.50	1.7
29	0	RETRACT	2.80	3.50	1.7
29	80	C.L.O.	3.80	4.80	2.9
29	80	C.L.A.	2.80	3.70	2.1
29	80	T.L.O.	3.80	4.80	2.9
29	80	T.L.A.	2.80	3.70	2.1
22	80	C.L.O.	5.90	7.20	2.7
22	80	T.L.O.	5.90	7.20	2.7
22	120	C.L.O.	7.90	9.90	3.1
22	120	T.L.O.	7.90	9.90	3.1

Table 3

Stroke variation (main and auxiliary motors)

Applied voltage	Load (lb.)	Condition of load	Max. error on centre distances	
			Retracted	Extended
29	80	T.L.A.	—	+0.060 in.
29	80	C.L.A.	-0.060 in.	—
22	80	T.L.O.	+0.050 in.	—
22	80	C.L.O.	—	-0.050 in.

RESTRICTED

Insulation resistance test

25. Before the final insulation resistance test, complete the assembling of the actuator. Assemble the outer cover to the actuator as described in para. 16, coating the gasket with compound as described in para. 12. Lock all drilled head screws with 22 s.w.g. stainless steel locking wire.

26. Repeat the insulation resistance test specified in para. 19.

RECONDITIONING (MOTORS)

Tools and test equipment (motors)

27. The special tools and test equipment listed in Table 4 are required for the re-conditioning of the motors.

DISMANTLING

28. When the motors have been removed from the actuator, dismantle them in the following manner:—

(1) Holding the drive pinion with the special tool T336913, remove the screw and slotted nut from the armature shaft. The brake spring will force the brake plate and the attraction plate out of the housing. Remove the plates and the spring, and withdraw the drive pin.

(2) Disconnect the lead, which passes through the brushgear housing, from its terminal. Unscrew the screws which secure the brush tags and remove the brushes from their holders. Remove the two slotted nuts from the ends of the long

Table 4

Special tools and test equipment (motor)

Nomenclature	Part No.	Ref. No.
TOOLS		
Drive pinion locking ring with feeler gauges	T336913	
Drive-end bearing support	T336905	
Bush for drive-end bearing support	T336912	
Press tool for comm.-end bearing	T336916	
Press for arbor press	T336906	
Spring checking tool	T336908	
Torque pulley comprising:—		
Pulley	T336917 detail 1	
Washer	T336917 detail 2A	
Screw	T336917 detail 3	
Collet	T336917 detail 4	
Bearing extractor for $\frac{1}{2}$ in. bearing	T336907	
Bearing extractor for $\frac{3}{8}$ in. bearing	T336919	
Slotted screwdriver	T336911	
Crimping pliers	CZ50125	
Crimping jaws for pliers	Z50102	
Hellermann sleeving tool	Type 'S'	
TEST EQUIPMENT		
Torque test rig	4CZ94028	

studs protruding through the brushgear housing. Screw the protective cap (part of extractor T336907) on to the armature shaft. Holding the yoke in one hand, tap lightly on the cap with a plastic headed mallet or similar tool until the journal on the armature shaft is clear of the drive-end bearing, or until the bearing leaves the brake housing. Then, guiding the leads through the holes in the brushgear housing, withdraw the latter housing, complete with armature, from the remainder of the motor.

(3) Remove the retaining ring, bearing cover plate and shims from the brushgear housing. Using a suitable brass drift, press out the end of the armature shaft from the commutator end bearing. If the bearing remains on the shaft and is removed from its housing during this operation, the bearing can be removed with the extractor T336919. If the extractor is used, the bearing shield will become distorted and must be renewed when the motor is reassembled.

(4) Remove the brush carrier from the brushgear housing by removing the two securing screws, taking care not to damage the insulating washer and carefully retaining the two kidney-shaped clamp plates.

(5) If the commutator-end bearing remained in its housing, press out the bearing, applying pressure to its outer race.

(6) Remove the thread which binds the leads to the long studs within the yoke

and unsolder the brake-coil lead from the tag on the field coil. Easing the leads through the gap between the studs and the yoke, withdraw the brake housing from the yoke. Remove the insulating sleeves from the studs.

(7) Withdraw the brake coil from the brake housing. Remove and carefully retain the shims on each stud.

(8) If the drive-end bearing remained in its housing, heat the brake housing in an oven to approximately 100 deg. C. and press out the bearing. Remove the shim from the housing. If the bearing remained on the armature shaft, it can be removed with the extractor T336907, using the cap to protect the end of the shaft.

INSPECTION AND REPAIR

29. As far as is practicable, inspection and repair are dealt with assembly by assembly.

Soldered joints

30. Where a soldered joint is made, the solder must not be allowed to run back along the cable as this will stiffen the cable and render it liable to fracture. When the joint has been made it should be coated with lacquer (*see para. 10*).

Brake housing

31. All traces of carbon dust must be removed, both from the housing and the brake components. This is best done by

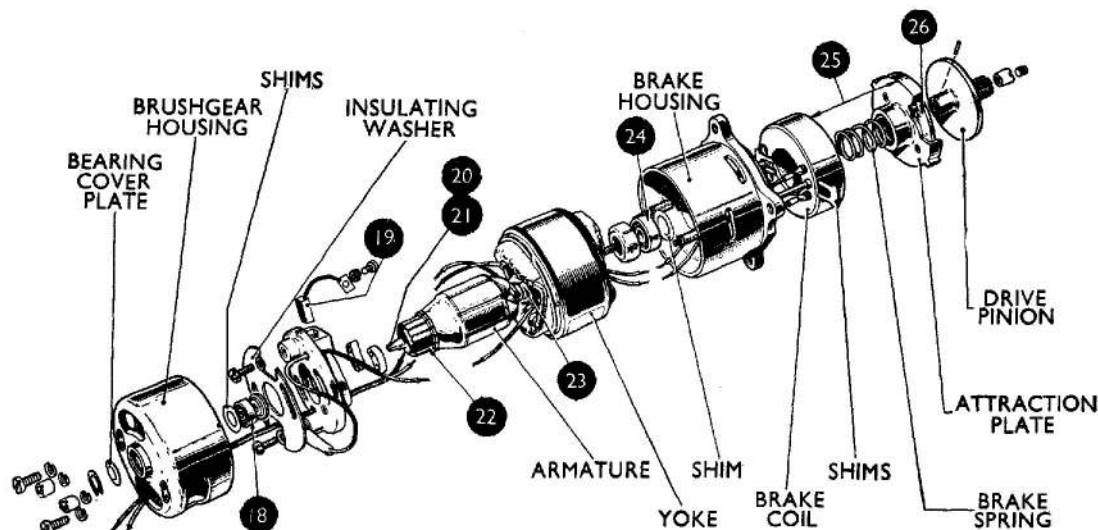

Fig. 5. Exploded view of motor

RESTRICTED

loosening it with a pencil-type brush and then using clean, dry, compressed air to remove it.

32. Examine the brake housing for damage, paying particular attention to the mounting flange, torque reaction slots and spigot.

33. Check that the dimension from the back of the attraction plate to the proud face of the friction lining is within the permissible limits (*see App. 1*); if it is not, replace with a new assembly.

34. The brake spring must be inspected for fatigue. The two-part tool T336908 is used for this examination. The weight required to compress the spring to a length of $\frac{5}{16}$ in. shall be 7 lb. 4 oz. \pm 4 oz. With the top of the plunger level with the top of the tube, the spring is compressed to a length of exactly $\frac{5}{16}$ in. Note that the plunger weight of 2 oz. must be taken into account.

35. Examine the drive pinion for wear and renew if necessary.

36. The two leads attached to the solder tags on the brake coil assembly must be renewed. The appropriate lengths required are $3\frac{1}{2}$ in. and $1\frac{3}{4}$ in.

37. Check the continuity resistance of the brake coil. The resistance must be between 1.00 and 1.10 ohms at 15 deg. C.

38. Renew, if necessary, the insulating sleeving on the long studs using 2 mm. bore tubing (yellow).

Yoke

39. Clean the yoke and field coils as described in para. 31 and make a general examination for damage. Check the continuity of each field coil. The resistance must be between 1.75 and 1.95 ohms at 15 deg. C. Renew the wiring leads, changing them one at a time to ensure their identity is maintained. Each lead should be immediately identified after changing by fitting sleeving of the correct colour; where necessary, renew the sleeving. The flying leads are 6 in. long.

40. If it is necessary to renew the yoke assembly, the serial number of the original assembly should be stamped on the label of

the new assembly and the original serial number obliterated.

Brushgear

41. Thoroughly clean the brushgear, removing the carbon dust as described in para. 31. Examine the moulding for damage and renew if necessary. Check the brush pressure as follows. Slide new brushes into the holders, but do not secure the tags at this stage. With a standard spring or dial type gauge, measure the pressure at the face of the brush when it projects $\frac{3}{32}$ in. from the holder. The pressure must be between $3\frac{1}{2}$ and $4\frac{1}{2}$ oz. (100 and 130 grammes). If it is not so, the brushgear assembly must be renewed.

Armature

42. Clean thoroughly and examine for damage. The commutator is best cleaned with a piece of linen. Check the resistance between any pair of diametrically opposed commutator segments. The resistance must be between 0.85 and 0.95 ohms at 15 deg. C.

43. Measure the shaft journal for wear and see that they are within the limits given in App. 1.

44. Check the commutator for wear (*see App. 1*). If a track more than 0.005 in. deep is present, the commutator must be trued by skimming. During this process it should be run on the shaft journals, not between centres. The diameter over the segments must not be less than 0.470 in. at the completion of skimming. This must be followed by undercutting the mica 0.024 in. to 0.026 in. wide and 0.020 in. to 0.025 in. deep.

Insulation resistance test

45. Using a 500-volt insulation resistance tester, measure the insulation resistance of all wound assemblies, i.e., brake coil, field coils and armature. Each assembly must not be less than 50 megohms.

Bearings

46. Immediately prior to lubrication, the bearings must be cleaned at least three times in white spirit, the final clean being in fresh white spirit. After cleaning, dry out the bearings with clean compressed air from a low-pressure line. Do not allow the air to

spin the races as, with no grease present, the resulting metal-to-metal contact can damage the bearings. Carefully examine the bearings for wear or damage and renew if necessary. Re-grease immediately after drying.

47. Each side of the bearings must be lubricated with grease XG-275 pressed into the space between the inner and outer race for a distance of one-third its circumference. If one side is inaccessible, then two-thirds of the accessible side must be covered. The bearings must then be rotated by hand to work the grease into the ball tracks.

ASSEMBLING

48. Assemble each motor in the sequence set out below:—

(1) If a new drive-end bearing is to be fitted, it must be selected from stock to give the correct fit as stated in App. 1. Clean and lubricate the bearing in accordance with the instructions in para. 46 and 47.

(2) Ensure that the bearing aperture in the brake housing is perfectly clean, then heat the housing to approximately 100 deg. C. Place the 0.005 in. shim into the bearing aperture. Support the housing on the support T336905 and bush T336912, and using T336906 in an arbor press, press the bearing fully home in the aperture, with the shielded side uppermost.

(3) Place the brake coil into the brake housing with the leads adjacent to the slot in the periphery of the housing. Slide the lengths of 2 mm. yellow tubing on to the studs.

(4) Coat the spigot face of the yoke with lacquer (*see para. 10*) and offer up the yoke assembly to the brake housing, ensuring that the pin in the yoke aligns with the slot in the housing.

(5) The leads from the brake coil must be fed through the yoke assembly on either side of the stud and to the outside of the stud; i.e., between the field coils, the stud and the outer casing; not on the inside of the stud. Make the soldered connection between the shorter brake coil lead and one of the common field-coil solder tags. Sleeve the longer lead from the brake coil with yellow tubing to the point where it emerges from the field coils. with two complete turns of thread, bind

the two field coil leads and the longer brake coil lead to the studs.

(6) In order to fit the armature shaft into the drive-end bearing, and to fit the commutator-end bearing and brushgear housing, it is essential to support the partly assembled motor on the inner race of the drive-end bearing. The tool T336905 is designed for this purpose.

(7) With the motor supported with its drive end downward on the tool, insert the threaded end of the armature shaft into the drive-end bearing. Using a brass cap over the other end of the shaft, press the armature fully home into the drive-end bearing.

(8) Assemble the insulating washer and brushgear assembly, without brushes, to the brushgear housing. Refer to fig. 5 when securing the assembly with two screws, spring washers and clamp plates.

(9) Prepare the commutator-end bearing as previously described in sub-para. (1) for the drive-end bearing.

(10) Ensure that the bearing aperture in the brushgear housing is perfectly clean, then heat the housing to approximately 100 deg. C. Coat the spigot face of the yoke with lacquer. Place the housing in position on the yoke, threading the leads through the appropriate holes and aligning the pin in the yoke with the slot in the housing. Support the inner race of the drive-end bearing on the tool T336905. Assemble the bearing shield and bearing, and press them home in the housing and on to the armature shaft with tool T336916.

(11) Fit the two spring washers and slotted nuts on the stud ends and, tightening each nut a turn or fraction of a turn alternately, tighten the whole assembly.

(12) Shims of 0.020 in., 0.002 in. and 0.005 in. thickness are used to pack out the gap between the bearing and the bearing cover plate. Select shims so that, when the cover plate is in position, the outermost shim still has a little clearance. On no account must the shims be tightly clamped by the cover plate. The permissible armature end float is given in App. 1.

(13) Fit the cover plate and retaining ring to the housing and remove the motor from the supporting tool.

(14) The terminal tags and sleeves must now be fitted to the lead ends. The tag and thimble are crimped on to the con-

RESTRICTED

ductor with a crimping tool (Table 4). The sleeving is pushed over the thimble and lacquered before applying the rubber sleeve with the Hellerman tool.

(15) Apply the coded sleeves to the flying leads, the OUT being fitted on the blue lead and the IN fitted on the red lead.

(16) It is convenient at this stage to carry out the rotation inspection and to bed new brushes if these are being fitted. Refer to para. 50 and 51.

(17) Fit the drive pin and place the brake spring over the armature shaft followed by the attraction plate, friction lining outwards. Note the radial position of the drive pin relative to the housing. Pass the brake plate over the shaft and, applying finger pressure to compress the spring, press the plate into position. Fit the nut and screw on to the armature shaft and tighten.

(18) The brake air gap, which is accessible through the two forward slots in the brake housing, must be set to between 0.008 in. and 0.011 in. at normal room temperature; use feelers attached to the pinion spanner. The gap is to be set by inserting shims through the two rearward slots in the housing after slackening the two slotted nuts on the brushgear housing. Having retightened these carefully, in the manner described in sub-para. (11), with some shims in position the air gap must be checked for uniformity by rotating the drive pinion through 45 deg. and checking with feelers through the forward slots. This process is repeated until the pinion has been turned through 180 deg.

TESTING

Motors

49. After assembly, the motors are to be subjected to the acceptance tests set out below.

Direction of rotation

50. With the common terminal connected to the negative lead of an 18-volt d.c. supply and the blue field lead to the positive, the armature must rotate in a clockwise direction when viewed from the drive end. The rotation is reversed when the red field lead is connected to the positive.

Running in

51. Brushes must be bedded in to the correct contour. This is done by running the motor in each direction alternately on no load with the brake mechanism removed. The supply voltage must be regulated so that the motor does not exceed 15,000 r.p.m. This is continued until the brushes are bedded over the complete arc and over at least 80 per cent of their area. During running in, the motor should be checked periodically for overheating. After running in, the brushgear must be cleaned out with clean, dry, compressed air.

Brake air gap

52. Having set the gap, check for proper functioning by running the motor at 18-volt d.c. six times in each direction of rotation. Ensure that there is no excessive vibration.

Speed balance

53. The brushgear must be adjusted to give near equal speeds in both directions of rotation. This is done by slackening the two screws securing the brushgear to the housing and rotating the brushgear through an arc until the speed in each direction is within 2½ per cent of the mean speed.

Torque test

54. The torque test is carried out with the motor at room temperature. By means of the torque pulley attached at the driving pinion and a torque test rig, record speed and current for torque loadings of 1.5, 3.0 and 4.0 oz. in. at 18, 25 and 29-volt d.c. in each direction of rotation. The performance of the motor must be in accordance with the figures in Table 5.

55. During these tests the brushes must be observed to check sparking. Commutation is satisfactory if either continuous or intermittent blue pin-point sparking is observed or if no sparking is observed. Sparking with occasional or continuous yellow flashes is not acceptable.

56. Care must be taken during torque tests not to overheat the motor.

Insulation resistance test

57. With the motor still warm from the torque test, the insulation between the com-

Table 5
Torque test

Terminal volts d.c.	Torque (oz./in.)	R.P.M.		Max. current (amp.)
		Max.	Min.	
18	1.5	—	9,500	2.3
18	3.0	—	3,500	3.3
25	1.5	—	16,000	2.3
25	3.0	—	10,000	3.4
25	4.0	—	7,200	4.0
29	1.5	24,000	—	2.2
29	3.0	16,500	—	3.5
29	4.0	13,000	—	4.1

mon lead and the motor frame must with stand 500 volts R.M.S. at 50 c.p.s. for one minute. The insulation resistance must then be measured between the same points and must not be less than 50 megohms at 500 volt d.c.

Brake overrun test

58. With the motor running at 20,000 r.p.m. and the input voltage at approximately 20 volts, the maximum overrun in switching off the supply should be 15 revolutions of the braking disc except where the brake spring and frictional material are new, when it should be 12 revolutions.

Re-check of brake air gap

59. With the motor at room temperature, the brake air gap must again be measured and, if necessary, re-adjusted and checked in accordance with para. 52.

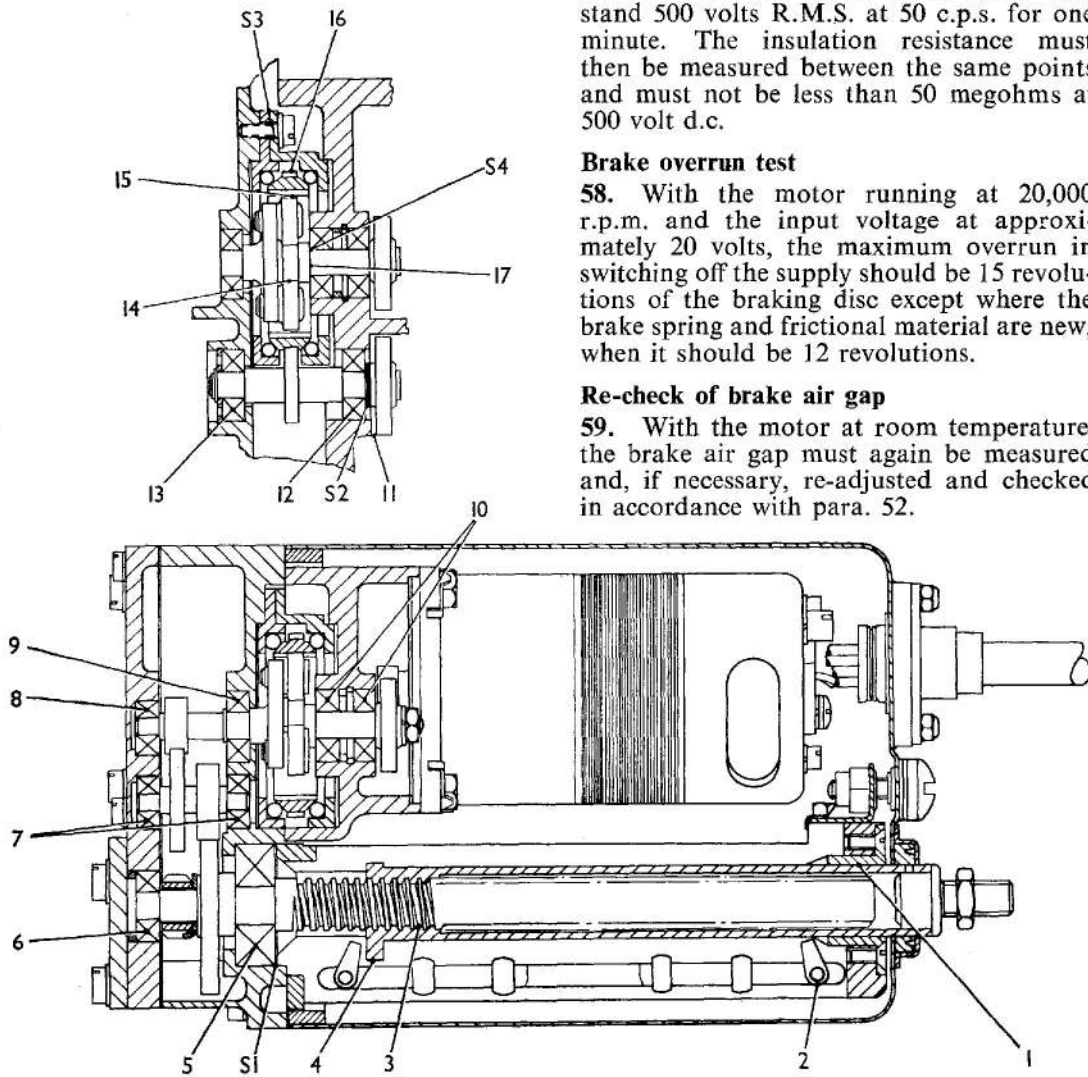

Fig. 6. Fits and clearances diagram

RESTRICTED

SCHEDULE OF FITS, CLEARANCES AND REPAIR TOLERANCES

(1CZ80383/1)

All dimensions in inches

APPENDIX 1

Note.—This schedule should be read in conjunction with fig. 6

Item No. (1)	Description (2)	Dimension New (3)	Permissible Worn Dimension (4)	Clearance New (5)	Permissible Worn Clearance (6)	Remarks (7)
Fig. 6	ACTUATOR					
1	PLUNGER IN BUSH	Plunger dia.	0.4995 0.4990	0.4990	0.0003 clear to 0.0014 clear	0.0014
		Bush bore	0.5004 0.4998	0.5004		
2	SWITCH OPERATING ROCKER SPINDLE IN BUSH	Spindle dia.	0.0920 0.0910	0.0910	0.010 clear to 0.030 clear	0.030
		Bush bore	0.0940 0.0930	0.0940		
3	LEADSCREW IN PLUNGER	Backlash in threads	—	—	0.0045	0.006
4	PLUNGER EARS IN GUIDE SLOTS	Ear width	0.2490 0.2480	0.2480	0.030 clear to 0.070 clear	0.070
		Slot width	0.2550 0.2520	0.2550		

RESTRICTED

RESTRICTED

SCHEDULE OF FITS, CLEARANCES AND REPAIR TOLERANCES

(1CZ80383/1)

APPENDIX 1 (continued)

All dimensions in inches

Item No. (1)	Description (2)	Dimension New (3)	Permissible Worn Dimension (4)	Clearance New (5)	Permissible Worn Clearance (6)	Remarks (7)	
5	MAIN BEARING	Centre housing bore	0.8666 ----- 0.8662	0.8666	Size to size 0.0009 clear	0.0009	
		Bearing dia.	0.8662 ----- 0.8657	0.8657			
		End float	—	—	0.003	0.003	Shim at S1
		Leadscrew journal dia.	0.2757 ----- 0.2754	0.2754	0.0005 interf. to	0.0002	
		Bearing bore	0.2756 ----- 0.2752	0.2756	0.0002 clear		
		GEARSHAFT JOURNALS IN BEARINGS					
6	1/2 in. BEARINGS Leadscrew (rear)	Journal dia.	0.1872 ----- 0.1867	0.1867	0.0001 clear to	0.0010	
		Bearing bore	0.1877 ----- 0.1873	0.1877	0.0010 clear		

SCHEDULE OF FITS, CLEARANCES AND REPAIR TOLERANCES

(1CZ80383/1)

F.S. 12

APPENDIX 1 (continued)

All dimensions in inches

Item No. (1)	Description (2)	Dimension New (3)	Permissible Worn Dimension (4)	Clearance New (5)	Permissible Worn Clearance (6)	Remarks (7)
9	Planet gear (front)	0.1872	0.1870	0.0001 clear to 0.0007 clear	0.0007	
10	Sungear (front and rear)	0.1870				
12, 13	Aux. drive (front and rear)	0.1877	0.1877			
		0.1873				
$\frac{3}{8}$ in. BEARINGS						
7	Intermediate (front and rear)	0.1247	0.1245	0.0001 clear to 0.0007 clear	0.0007	
8	Planet gear (rear)	0.1245				
		Bearing bore	0.1252	0.1252		
		0.1248				
GEARSHAFT BEARINGS IN HOUSINGS						
$\frac{1}{2}$ in. BEARINGS						
6	Leadscrew (rear)	0.4997	0.4993	0.0005 interf. to 0.0004 clear	0.0004	
9	Planet gear (front)	0.4993				
		13	Aux. drive (rear)	0.4997		
Housing bore	0.4992					

RESTRICTED

A.P.4343D, Vol. 6, Sect. 14, Chap. 93, App. 1
A.L. 70, July 59

RESTRICTED

SCHEDULE OF FITS, CLEARANCES AND REPAIR TOLERANCES

(1CZ80383/1)

APPENDIX 1 (continued)

All dimensions in inches

Item No. (1)	Description (10)	Dimension New (3)	Permissible Worn Dimension (4)	Clearance New (5)	Permissible Worn Clearance (6)	Remarks (7)
10	Sun gear (front and rear) Bearing dia.	<u>0.4997</u> 0.4993	0.4993	Size to size	0.0009	
12	Aux. drive (front) Housing bore	<u>0.5002</u> 0.4997	0.5002	0.0009 clear		
$\frac{3}{8}$ in. BEARINGS						
7	Intermediate (front and rear) Bearing dia.	<u>0.3747</u> 0.3743	0.3743	0.0005 interf. to	0.0004	
8	Planet gear (rear) Housing bore	<u>0.3747</u> 0.3742	0.3747	0.0004 clear		
11	AUXILIARY DRIVE GEAR Clearance ANNULUS AND PLANET GEAR ASSEMBLY	—	—	0.0320	0.0320	Shim at S2
14	Sun gear in planet gears Backlash	—	—	<u>0.0040</u> 0.0015	0.0040	
15	Planet gears in annulus Backlash	—	—	<u>0.0045</u> 0.0025	0.0045	

SCHEDULE OF FITS, CLEARANCES AND REPAIR TOLERANCES

(1CZ80383/1)

APPENDIX 1—contd.

All dimensions in inches

Item No. (1)	Description (2)	Dimension New (3)	Permissible Worn Dimension (4)	Clearance New (5)	Permissible Worn Clearance (6)	Remarks (7)
16	Annulus End float	—	—	0·0020 0·0005	0·0020 0·0005	Shim at S3
17	Sun gear shaft End float	—	—	0·0050 0·0010	0·0050 0·0010	Shim at S4
Fig. 5	MOTOR					
18	BEARING IN BRUSHGEAR HOUSING	Bearing dia. 0·3747 0·3743	0·3743	0·0005 interf. to 0·0004 clear	0·0004	
		Housing bore 0·3747 0·3742	0·3747			
19	BRUSHES	Length 0·385 0·355	0·250	—	—	
20	ARMATURE SHAFT IN COMM.-END BEARING	Shaft dia. 0·1253 0·1248	—	Size to size	—	Bearing selected to obtain fit in column (5)
		Bearing bore 0·1252 0·1248	—	0·0001 interf.		

RESTRICTED

This file was downloaded
from the RTFM Library.
Link: www.scottbouch.com/rtfm

Please see site for usage terms,
and more aircraft documents.

