

## Chapter 18

### PUMP, FUEL, SPE.802 SERIES

#### LIST OF CONTENTS

	<i>Para.</i>		<i>Para.</i>
<i>Introduction</i> ....	1	<i>Electrical connection (female)</i> ....	45
<b>Reconditioning</b>		<b>Testing</b>	
<i>Tools and test equipment</i> ....	3	<i>General</i> ....	46
<b>Dismantling</b>		<i>Test equipment</i> ....	47
<i>General</i> ....	4	<i>Preparation</i> ....	48
<i>Separation of the motor and pump units</i>	6	<b>Schedule of tests</b>	
<i>Dismantling the pump unit</i> ....	7	<i>Brush bedding and motor torque test</i> ....	49
<i>Dismantling the motor unit</i> ....	14	<i>Insulation resistance test</i> ....	50
<b>Cleaning, inspection and repair</b>		<i>Pressure test</i> ....	51
<i>Cleaning</i> ....	17	<i>Starting test</i> ....	52
<i>Inspection</i> ....	18	<i>Dry test</i> ....	53
<b>Assembling</b>		<i>Proof test</i> ....	54
<i>General</i> ....	20	<i>Calibration test</i> ....	55
<i>Motor unit</i> ....	21	<i>Dismantling for inspection</i> ....	56
<i>Pump unit</i> ....	29		
<i>Motor unit to pump unit</i> ....	37		

#### LIST OF TABLES

	<i>Table</i>		<i>Table</i>
<i>Special tools and equipment</i> ....	1	<i>Proof test</i> ....	4
<i>Detailed inspection of components</i> ....	2	<i>Acceptance performance</i> ....	5
<i>Schedule of fits, clearances and repair tolerances</i> ....	3	<i>Faults, possible causes and remedies</i> ....	6

#### LIST OF ILLUSTRATIONS

	<i>Fig.</i>		<i>Fig.</i>
<i>Motor unit</i> ....	1	<i>Motor unit clamp</i> ....	13
<i>Pump unit</i> ....	2	<i>Brush gear retarding fixture</i> ....	14
<i>Pump/motor assembly</i> ....	3	<i>Brush gear setting, circuit diagram 1</i> ....	15
<i>Pump/motor assembly</i> ....	4	<i>Brush gear setting, circuit diagram 2</i> ....	16
<i>Exploded view of pump unit</i> ....	5	<i>Bellows housing assembly</i> ....	17
<i>Exploded view of motor unit</i> ....	6	<i>Bellows unit lubrication holes</i> ....	18
<i>Exploded view of electrical connection</i> ....	7	<i>Bellows gland loading fixture</i> ....	19
<i>Hand press</i> ....	8	<i>Determination of bevel pinion shimming</i>	20
<i>General tools</i> ....	9	<i>Backlash checking tools</i> ....	21
<i>Bellows housing removal</i> ....	10	<i>Pressure test fixture</i> ....	22
<i>Bearing sleeve removal and assembly</i> ....	11	<i>Diagrammatic arrangement of suitable test rig.</i> ....	23
<i>Impeller, helix and vapour guide cone clearances</i> ....	12		

#### LIST OF APPENDICES

	<i>App.</i>		<i>App.</i>
<i>Reconditioning SPE.802 Mk. 2 fuel pump</i>	1	<i>Reconditioning SPE.802 Mk.3 fuel pump</i>	2

~~RESTRICTED~~

## Introduction

1. A general description of the type SPE.802 series fuel booster pump is given in A.P.4343D, Vol. 1, Sect. 7, Chap. 18. Details of the SPE.802 fuel booster pump and the variations between the different mark numbers are given in the appendix to the above chapter. Reconditioning instructions are given for SPE.802B Mk. 3, with appendices covering differences in procedure for the earlier pumps in the series.

2. The pump assembly comprises a pump unit driven through a right-angled reduction gearing by a 24 volts d.c. motor unit. Dismantling for re-conditioning is carried

out in three stages:—(1) The separation of pump and motor units, (2) the dismantling of the pump assembly and (3) the dismantling of the motor unit. Conversely during assembly the motor unit and pump unit are built up as two separate sub-assemblies which are then brought together and assembled as a final stage.

## RECONDITIONING

### Tools and test equipment

3. In addition to the standard bench tools, the special tools listed in Table 1 are required to overhaul the SPE.802 fuel booster pumps. Details of a suitable test rig are included in para. 47.

Table 1

### Special tools and equipment

Nomenclature	Part Number	Fig. No.	Ref. No.
Hand press for general use	SPE.10143	8	
Base plate	SPE.10766	11	
Spigot	} Bearing sleeve removal and assembly	SPE.16020	11
Collar		SPE.16021	11
Pad		SPE.16022	11
Gear wheel extractor		SPE.17370	9
Gear wheel key	SPE.17371	9	
Impeller gauge	SPE.17372	9	
Bellows seal body extractor	SPE.17373	9	
Helix shroud spanner	SPE.17374	9	
Calibrated fan	SPE.17398	9	
Reaming bush	SPE.17376	9	
Guide collar (reaming)	SPE.17377	9	
Reamer	SPE.17378	9	
Grease gauge	SPE.17379	9	
Drift—bellows housing removal	SPE.17380	10	
Register—bellows housing removal	SPE.17381	10	
Punch—bellows housing assembly	SPE.17382	17	
Register—bellows housing assembly	SPE.17383	17	
Shaped brush	SPE.17385	14	
Locking strip	SPE.17386	14	
Retarding fixture	SPE.17399	14	
Weight—bellows unit loading	SPE.17388	19	
Support fixture	SPE.17389	19	
Pump unit disc	} Bevel pinion shimming	SPE.17390	20
Motor unit disc		SPE.17391	20
Motor unit clamp	SPE.17392	20	
Casing	} Backlash check	SPE.17393	21
Indexing clamp		SPE.17394	21
Clamp screw (casing)		SPE.17395	21
Starwheel		SPE.17396	21
Pressure test fixture	SPE.17397	22	
Test rig (diagrammatic)	—	23	

~~RESTRICTED~~

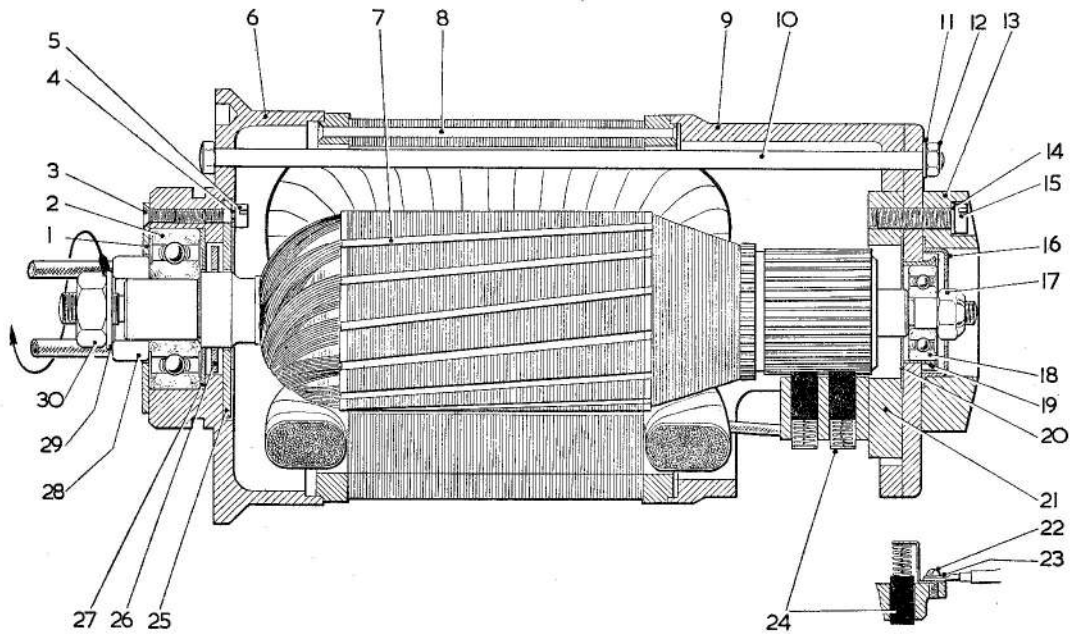

- |    |                             |                            |    |                                      |
|----|-----------------------------|----------------------------|----|--------------------------------------|
| 1  | BEARING RETAINER PLATE      |                            | 16 | BEARING COVER PLATE                  |
| 2  | BALL BEARING                |                            | 17 | $\frac{1}{4}$ IN. B.S.F. BEARING NUT |
| 3  | C/SK. HD. SCREW             |                            | 18 | COMMUTATOR END BALL BEARING          |
| 4  | SPRING WASHER               | } SEAL WASHER<br>ATTACHING | 19 | BEARING SLEEVE                       |
| 5  | CHEESE HD. SCREW            |                            | 20 | DUST SHIELD                          |
| 6  | FRONT MOTOR CASING          |                            | 21 | BRUSH BOX ASSEMBLY                   |
| 7  | ARMATURE ASSEMBLY           |                            | 22 | RD. HD. SCREW (BRUSH SECURING)       |
| 8  | STATOR ASSEMBLY             |                            | 23 | SHAKEPROOF WASHER (BRUSH SECURING)   |
| 9  | COMMUTATOR-END MOTOR CASING |                            | 24 | BRUSH AND TAG ASSEMBLY               |
| 10 | TIE-BOLT                    |                            | 25 | SEAL WASHER                          |
| 11 | TIE-BOLT PLAIN WASHER       |                            | 26 | FLOATING WASHER                      |
| 12 | TIE-BOLT NUT                |                            | 27 | DUST SHIELD                          |
| 13 | BRUSH BOX RETAINER          |                            | 28 | SPECIAL SPACER BUSH                  |
| 14 | SPRING WASHER               |                            | 29 | CLAMP WASHER (PLAIN)                 |
| 15 | BRUSH BOX SECURING SCREW    |                            | 30 | LOCKNUT                              |

Fig. 1. Motor unit

**DISMANTLING**

Refer to Fig. 1-4 (Sectional views) and fig. 5-7 (exploded views).

**General**

4. Cut the locking wires to all external seals.

5. *Removing the capacitors.*

(1) Remove fourteen screws (113), washers (114) and nuts (137) as well as two screws

(155) and washers (156). Withdraw the capacitor cover assembly.

(2) Remove screw (135) and spring washer (134) together with locknuts (117) and washers (116) to free the capacitor panel assembly. Withdraw this panel as far as the field and electrical connecting leads will allow.

(3) Disconnect the field and plug connections from the capacitor units by removing nuts (164), shakeproof washers (163) and

**RESTRICTED**

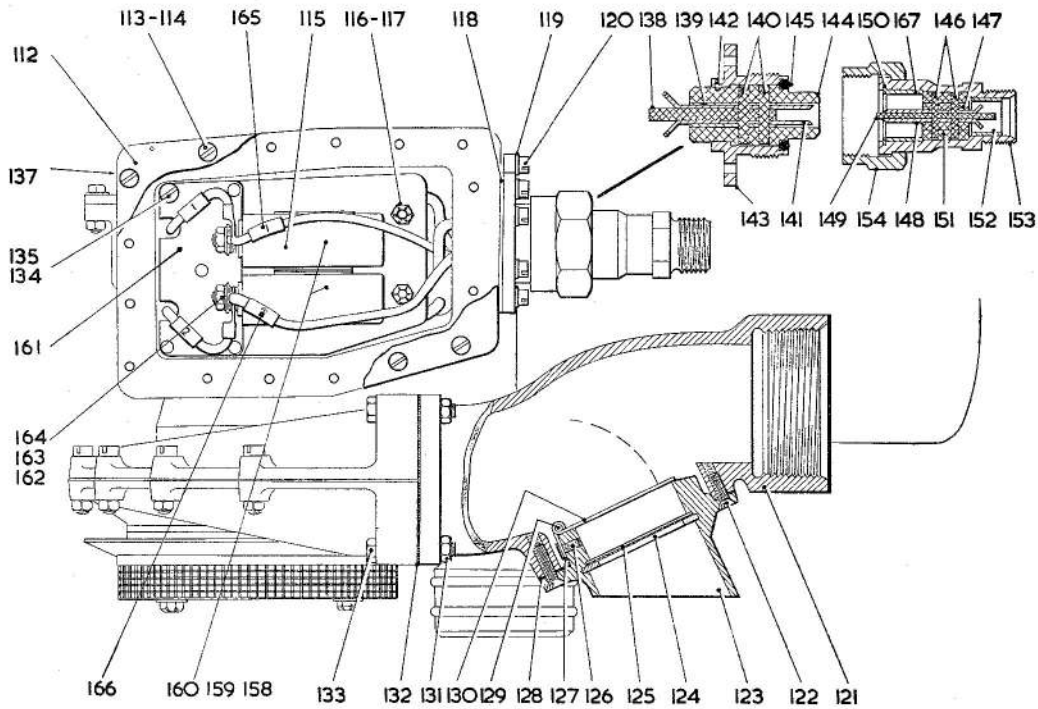

- |     |  |     |                                      |
|-----|--|-----|--------------------------------------|
| 112 | CAPACITOR COVER ASSEMBLY                       | 137 | NUT (CAPACITOR COVER FIXING)         |
| 113 | CH.HD. SCREW (CAPACITOR COVER FIXING)          | 138 | INSULATION PLATE                     |
| 114 | SPRING WASHER (CAPACITOR COVER FIXING)         | 139 | INSULATION STRIP                     |
| 115 | CAPACITOR PANEL ASSEMBLY                       | 140 | LOCKING PIN                          |
| 116 | PLAIN WASHER                                   | 141 | CONTACT PLATE                        |
| 117 | SELF-LOCKING NUT (PANEL FIXING)                | 142 | GRUBSCREW                            |
| 118 | ELECTRICAL CONNECTION GASKET                   | 143 | FLANGED HOUSING                      |
| 119 | SHAKEPROOF WASHER                              | 144 | INSULATION BODY                      |
| 120 | CH.HD. SCREW (ELECTRICAL CONNECTION FIXING)    | 145 | O RING                               |
| 121 | OUTLET CASTING                                 | 146 | LOCKING PIN                          |
| 122 | C/SK.HD. SCREW                                 | 147 | OUTER INSULATION PLATE               |
| 123 | BY-PASS VALVE HOUSING                          | 148 | CONTACT PLATE                        |
| 124 | CIRCLIP  | 149 | CENTRAL INSULATION PLATE             |
| 125 | FILTER   | 150 | CIRCLIP                              |
| 126 | C/SK.HD. SCREW                                 | 151 | LOCKING BUSH                         |
| 127 | HINGE PLATE                                    | 152 | INSULATION BUSH                      |
| 128 | BY-PASS VALVE GASKET                           | 153 | SOCKET BODY                          |
| 129 | HINGE PIN                                      | 154 | UNION NUT                            |
| 130 | VALVE PLATE                                    | 158 | CH.HD. SCREW (CAPACITOR FIXING)      |
| 131 | LOCKNUT  | 159 | SHAKEPROOF WASHER (CAPACITOR FIXING) |
| 132 | VOLUTE/OUTLET GASKET                           | 160 | CAPACITOR                            |
| 133 | HEX.HD. BOLT (OUTLET TO VOLUTE)                | 161 | CAPACITOR PANEL                      |
| 134 | SPRING WASHER                                  | 162 | PLAIN WASHER                         |
| 135 | CH.HD. SCREW (CAPACITOR PANEL TO PUMP CASTING) | 163 | SHAKEPROOF WASHER                    |
|     |  | 164 | LOCKNUT                              |
|     |  | 165 | ELECTRICAL CONNECTION LEAD (UPPER)   |
|     |  | 166 | ELECTRICAL CONNECTION LEAD (LOWER)   |
|     |  | 167 | INSULATION BUSH                      |

Fig. 4. Pump/motor assembly

~~RESTRICTED~~

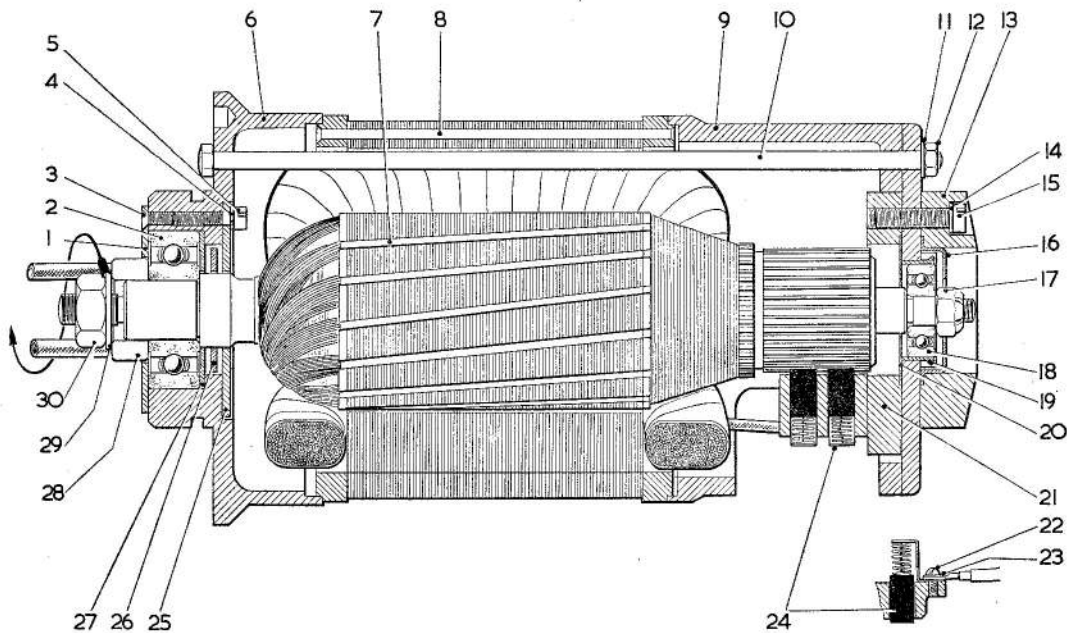

- |    |                             |    |                                      |
|----|-----------------------------|----|--------------------------------------|
| 1  | BEARING RETAINER PLATE      | 16 | BEARING COVER PLATE                  |
| 2  | BALL BEARING                | 17 | $\frac{1}{4}$ IN. B.S.F. BEARING NUT |
| 3  | C/SK. HD. SCREW             | 18 | COMMUTATOR END BALL BEARING          |
| 4  | SPRING WASHER               | 19 | BEARING SLEEVE                       |
| 5  | CHEESE HD. SCREW            | 20 | DUST SHIELD                          |
| 6  | FRONT MOTOR CASING          | 21 | BRUSH BOX ASSEMBLY                   |
| 7  | ARMATURE ASSEMBLY           | 22 | RD. HD. SCREW (BRUSH SECURING)       |
| 8  | STATOR ASSEMBLY             | 23 | SHAKEPROOF WASHER (BRUSH SECURING)   |
| 9  | COMMUTATOR-END MOTOR CASING | 24 | BRUSH AND TAG ASSEMBLY               |
| 10 | TIE-BOLT                    | 25 | SEAL WASHER                          |
| 11 | TIE-BOLT PLAIN WASHER       | 26 | FLOATING WASHER                      |
| 12 | TIE-BOLT NUT                | 27 | DUST SHIELD                          |
| 13 | BRUSH BOX RETAINER          | 28 | SPECIAL SPACER BUSH                  |
| 14 | SPRING WASHER               | 29 | CLAMP WASHER (PLAIN)                 |
| 15 | BRUSH BOX SECURING SCREW    | 30 | LOCKNUT                              |
- } SEAL WASHER ATTACHING

Fig. 1. Motor unit

**DISMANTLING**

Refer to Fig. 1-4 (Sectional views) and fig. 5-7 (exploded views).

**General**

4. Cut the locking wires to all external seals.

5. *Removing the capacitors.*

(1) Remove fourteen screws (113), washers (114) and nuts (137) as well as two screws

(155) and washers (156). Withdraw the capacitor cover assembly.

(2) Remove screw (135) and spring washer (134) together with locknuts (117) and washers (116) to free the capacitor panel assembly. Withdraw this panel as far as the field and electrical connecting leads will allow.

(3) Disconnect the field and plug connections from the capacitor units by removing nuts (164), shakeproof washers (163) and

**RESTRICTED**

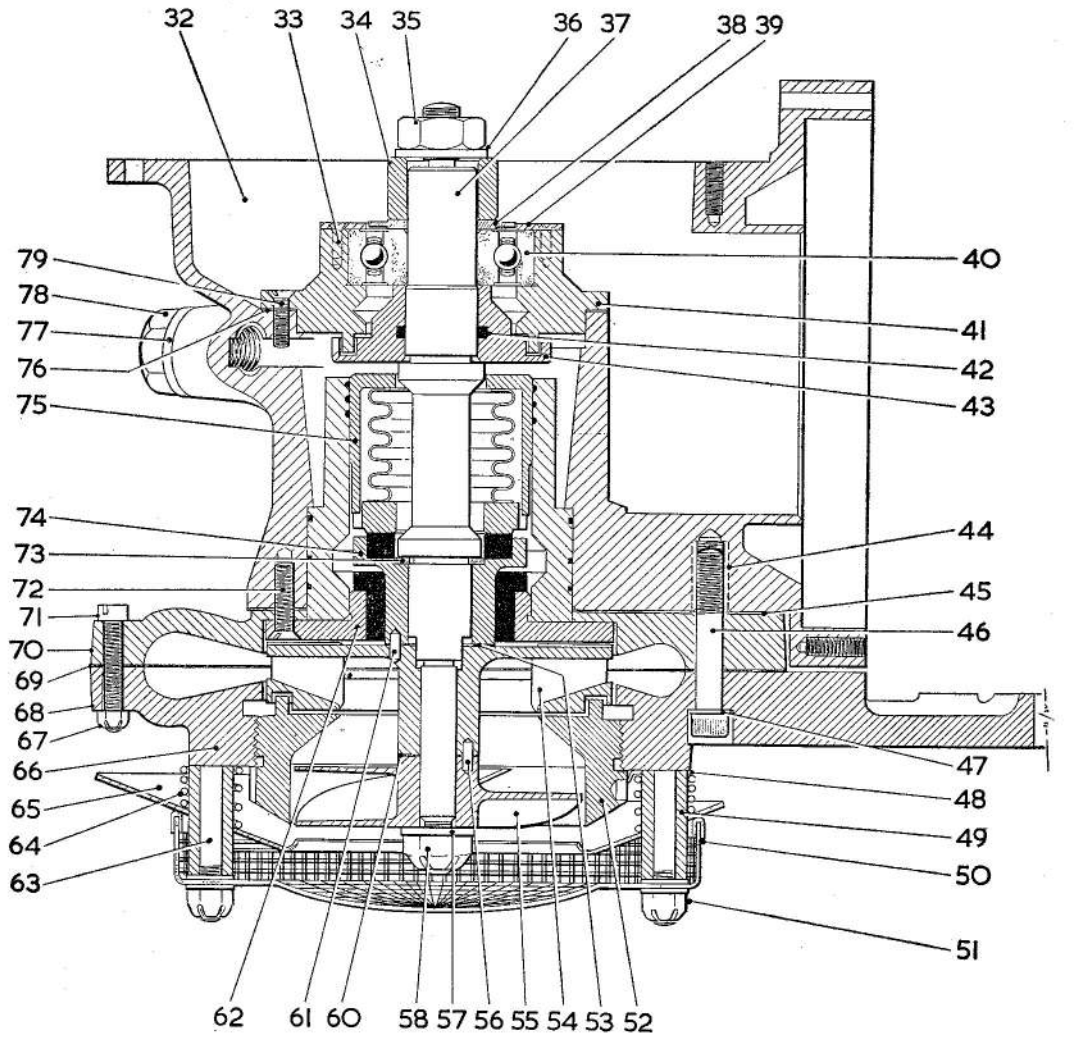

- |  |   |
|--|---|
| 32 PUMP BODY CASTING                           | 56 DOWEL (IMPELLER TO HELIX)                |
| 33 C/SK. HD. SCREW (BEARING RET. PLATE FIXING) | 57 CLAMP WASHER                             |
| 34 SPECIAL SPACING BUSH                        | 58 1/4 IN. B.S.F. SPINDLE END NUT           |
| 35 LOCKNUT                                     | 60 HELIX ADJUSTING SHIM                     |
| 36 CLAMP WASHER                                | 61 DOWEL (IMPELLER TO SEAL HOUSING)         |
| 37 PUMP SHAFT (SPINDLE)                        | 62 BASE BEARING HOUSING ASSEMBLY            |
| 38 BEARING DUST SHIELD                         | 63 STUD (VOLUTE ASSEMBLY)                   |
| 39 BEARING RETAINER PLATE                      | 64 SPRING                                   |
| 40 BALL BEARING                                | 65 VAPOUR GUIDE CONE                        |
| 41 BEARING HOUSING                             | 66 VOLUTE ASSEMBLY                          |
| 42 SEAL RING                                   | 67 SELF-LOCKING NUT (VOLUTE ASSEMBLY)       |
| 43 BEARING THROWER SEAL                        | 68 LOWER VOLUTE CASTING                     |
| 44 WIRE THREAD INSERT                          | 69 VOLUTE GASKET                            |
| 45 VOLUTE/PUMP BODY GASKET                     | 70 UPPER VOLUTE CASTING                     |
| 46 SOCKET HEAD SCREW                           | 71 CHEESE HEAD SCREW (VOLUTE ASSEMBLY)      |
| 47 SHAKEPROOF WASHER                           | 72 C/SK. HD. SCREW (BASE BEARING HOUSING)   |
| 48 HELIX SHROUD LOCKING TAB                    | 73 BELLOWS GLAND LOADING SHIM               |
| 49 PILLAR (FILTER SUPPORT)                     | 74 BELLOWS SEAL BODY ASSEMBLY               |
| 50 INLET FILTER                                | 75 BELLOWS HOUSING ASSEMBLY                 |
| 51 FILTER SECURING SELF-LOCKING NUT            | 76 GASKET (BEARING HOUSING/PUMP BODY)       |
| 52 HELIX SHROUD                                | 77 SEAL WASHER (DRAIN PLUG)                 |
| 53 IMPELLER ADJUSTING SHIM                     | 78 DRAIN PLUG                               |
| 54 CENTRIFUGAL IMPELLER                        | 79 C/SK. HD. SCREW (BEARING HOUSING FIXING) |
| 55 HELIX                                       |   |

Fig. 2. Pump unit

~~RESTRICTED~~

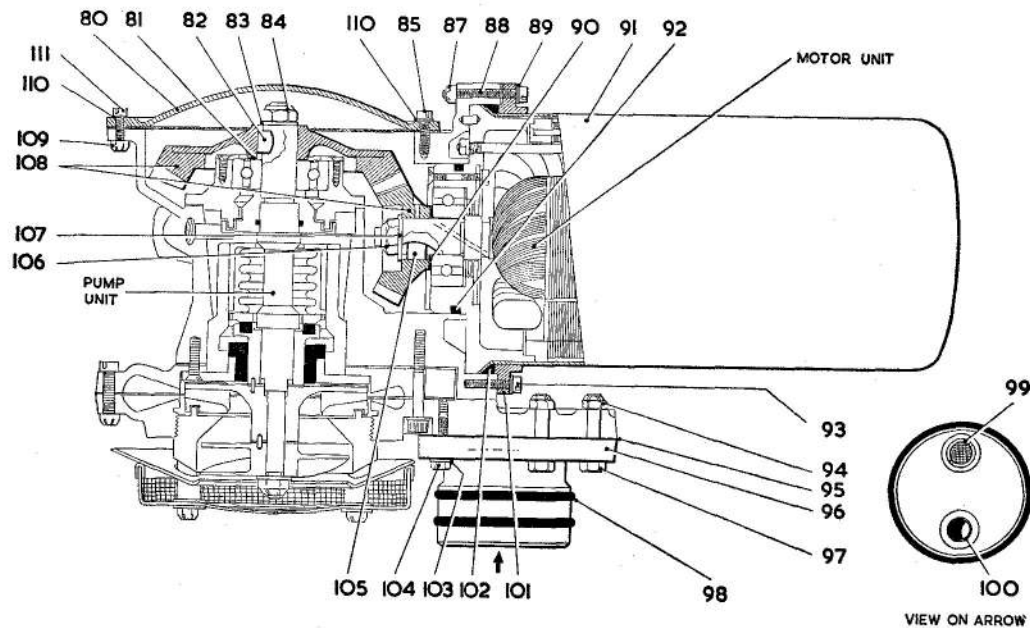

- |    |                                  |     |   |
|----|----------------------------------|-----|---|
| 80 | GEAR BOX COVER ASSEMBLY          | 97  | HEX.HD. BOLT (LOCATING PLUG FIXING)                   |
| 81 | BEVEL GEAR ADJUSTING SHIM        | 98  | LOCATING PLUG SEAL RING                               |
| 82 | DRIVE KEY                        | 99  | BREATHER PLUG ASSEMBLY                                |
| 83 | CLAMP WASHER                     | 100 | GLAND DRAIN TUBE                                      |
| 84 | BEVEL GEAR SELF-LOCKING NUT      | 101 | BOLT RING   |
| 85 | CH.HD. SCREW (GEAR BOX COVER)    | 102 | SEAL RING (OUTER CASING JOINT)                        |
| 87 | SELF-LOCKING NUT (MOTOR FIXING)  | 103 | SHAKEPROOF WASHER                                     |
| 88 | CH.HD. SCREW (MOTOR FIXING)      | 104 | HEX.HD. SCREW   |
| 89 | SHAKEPROOF WASHER (MOTOR FIXING) | 105 | DRIVE PIN   |
| 90 | BEVEL PINION ADJUSTING SHIM      | 106 | BEVEL PINION SELF-LOCKING NUT                         |
| 91 | OUTER MOTOR CASING               | 107 | CLAMP WASHER  |
| 92 | O RING (MOTOR TO PUMP UNIT)      | 108 | BEVEL GEAR AND PINION (SUPPLIED AS PAIRED COMPONENTS) |
| 93 | CH.HD. SCREW (MOTOR FIXING)      | 109 | SELF-LOCKING NUT (GEAR BOX COVER)                     |
| 94 | SELF-LOCKING NUT (LOCATING PLUG) | 110 | SPRING WASHER (GEAR BOX COVER)                        |
| 95 | LOCATING PLUG GASKET             | 111 | CH.HD. SCREW (GEAR BOX COVER).                        |
| 96 | LOCATING PLUG                    |     |   |

Fig. 3. Pump/motor assembly

plain washers (162). The capacitors can be separated from the panel by removing the two screws (158) and shakeproof washers (159) securing each unit.

#### Separation of the motor and pump units

##### 6. Separate motor unit from pump unit.

(1) Remove the seven nuts (109) and withdraw the gear box cover screws (111): (85)

together with the spring washers (110). Break the gear box cover seal. Remove as much grease as possible from the gear box. Do not use solvents.

(2) Remove the nuts, screws and shakeproof washers securing the bolt ring (101), and withdraw the motor outer casing (91), together with the seal ring (102). Support

~~RESTRICTED~~

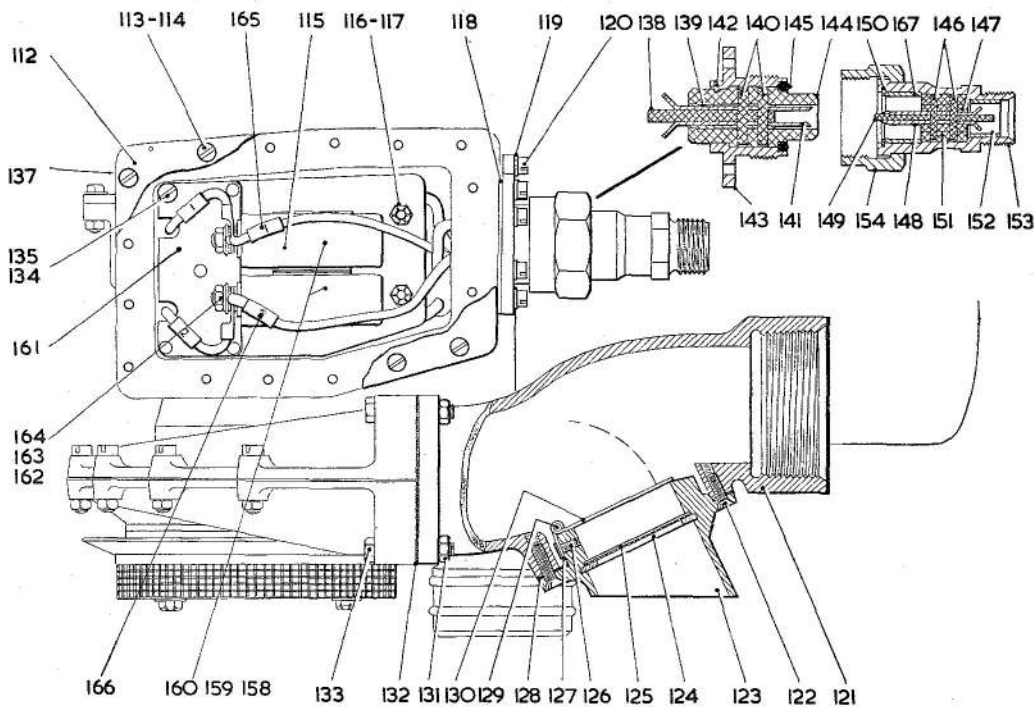

- |     |  |     |                                      |
|-----|--|-----|--------------------------------------|
| 112 | CAPACITOR COVER ASSEMBLY                       | 137 | NUT (CAPACITOR COVER FIXING)         |
| 113 | CH.HD. SCREW (CAPACITOR COVER FIXING)          | 138 | INSULATION PLATE                     |
| 114 | SPRING WASHER (CAPACITOR COVER FIXING)         | 139 | INSULATION STRIP                     |
| 115 | CAPACITOR PANEL ASSEMBLY                       | 140 | LOCKING PIN                          |
| 116 | PLAIN WASHER                                   | 141 | CONTACT PLATE                        |
| 117 | SELF-LOCKING NUT (PANEL FIXING)                | 142 | GRUBSCREW                            |
| 118 | ELECTRICAL CONNECTION GASKET                   | 143 | FLANGED HOUSING                      |
| 119 | SHAKEPROOF WASHER                              | 144 | INSULATION BODY                      |
| 120 | CH.HD. SCREW (ELECTRICAL CONNECTION FIXING)    | 145 | O RING                               |
| 121 | OUTLET CASTING                                 | 146 | LOCKING PIN                          |
| 122 | C/SK.HD. SCREW                                 | 147 | OUTER INSULATION PLATE               |
| 123 | BY-PASS VALVE HOUSING                          | 148 | CONTACT PLATE                        |
| 124 | CIRCLIP  | 149 | CENTRAL INSULATION PLATE             |
| 125 | FILTER   | 150 | CIRCLIP                              |
| 126 | C/SK.HD. SCREW                                 | 151 | LOCKING BUSH                         |
| 127 | HINGE PLATE                                    | 152 | INSULATION BUSH                      |
| 128 | BY-PASS VALVE GASKET                           | 153 | SOCKET BODY                          |
| 129 | HINGE PIN                                      | 154 | UNION NUT                            |
| 130 | VALVE PLATE                                    | 158 | CH.HD. SCREW (CAPACITOR FIXING)      |
| 131 | LOCKNUT  | 159 | SHAKEPROOF WASHER (CAPACITOR FIXING) |
| 132 | VOLUTE/OUTLET GASKET                           | 160 | CAPACITOR                            |
| 133 | HEX.HD. BOLT (OUTLET TO VOLUTE)                | 161 | CAPACITOR PANEL                      |
| 134 | SPRING WASHER                                  | 162 | PLAIN WASHER                         |
| 135 | CH.HD. SCREW (CAPACITOR PANEL TO PUMP CASTING) | 163 | SHAKEPROOF WASHER                    |
|     |  | 164 | LOCKNUT                              |
|     |  | 165 | ELECTRICAL CONNECTION LEAD (UPPER)   |
|     |  | 166 | ELECTRICAL CONNECTION LEAD (LOWER)   |
|     |  | 167 | INSULATION BUSH                      |

Fig. 4. Pump/motor assembly

~~RESTRICTED~~

the motor unit which is now free in the pump casting.

**Note . . .**

*It is strongly recommended that a new gear and pinion are fitted at each overhaul. These parts are paired prior to assembly and if the original set is to be reused, the meshing of the gear and pinion should be marked before dismantling so that on re-assembly the gear and pinion are returned to their original meshed position.*

(3) Ease the motor unit assembly out of the pump casting, taking care not to damage the field leads when pulling them back through the casting conduit. The pump unit and motor unit can now be separately dismantled.

**Dismantling the pump unit**

**7. Removing the electrical connection.**

(1) Detach the electrical connection assembly by removing the six screws and shakeproof washers. Ignore the damage to the gasket.

**Note . . .**

*Dismantle the electrical connection only if the assembly is damaged.*

(2) Remove the grub screw (142) and withdraw the insulation body (144) complete with the contact plates. Drive out the locking pins (140) and withdraw the insulation plate (138), insulation strips (139) and contact plates (141).

**8. Detaching and dismantling the outlet assembly.**

(1) Remove the four self-locking nuts (131) and bolts (133) securing the outlet assembly to the volute assembly.

(2) Separate the by-pass valve assembly from the outlet casting (121) by removing screws (122). Withdraw the gasket.

(3) Disassemble the by-pass valve only if the flap valve seating, or filter is damaged. The flap valve can be detached from the housing by removing the two screws (126). Separate the valve plate (130) from the hinge plate (127) by withdrawing the pin (129). Remove the circlip to extract the filter (125).

**9. Removing locating plug and inlet filter.**

(1) Remove the locating plug assembly by

unscrewing the nuts (94) from the three bolts and withdrawing the screws (104) together with the shakeproof washers. Ignore the damage to the gasket. Remove the seal rings (98) from the locating plug assembly. The breather plug assembly (99) need only be removed if the gauze appears damaged. Do not attempt to withdraw the copper drain tube.

(2) Remove the locknuts securing the filter assembly (50). Withdraw the filter together with the pillars, the vapour guide cone (65), the springs (64) and the helix shroud locking tab.

**10. Removing the helical and centrifugal impellers.**

(1) Holding the gear with the special key SPE.17371 (fig. 9), unscrew the lower spindle end nut and washer. Withdraw the helix (55) together with any adjusting shims fitted.

(2) Use the special spanner SPE.17374 (fig. 9) to remove the helix shroud (52) from the volute assembly. Withdraw the centrifugal impeller (54) from the spindle together with any shims fitted.

**11. Withdrawing the volute assembly.**

(1) Remove the five screws securing the lower bearing housing assembly (62) to the volute assembly and extract the housing assembly. Remove the three socket head screws and shakeproof washers securing the volute assembly to the pump casting. Break the joint between these two parts to remove the volute assembly. Ignore the damage to the joint washer. Do not attempt to remove the carbon bearing from the housing.

(2) The volute assembly need only be dismantled if the seal between the two halves is faulty or the components are otherwise damaged. To dismantle the volute assembly remove the seven self-locking nuts (67), withdraw the screws (71) and separate the volute halves (70) and (68). Replace any studs (63) as necessary.

**Note . . .**

*Keep the volute halves together as these have been machined as a pair.*

(3) Withdraw the bellows seal body as-

~~RESTRICTED~~

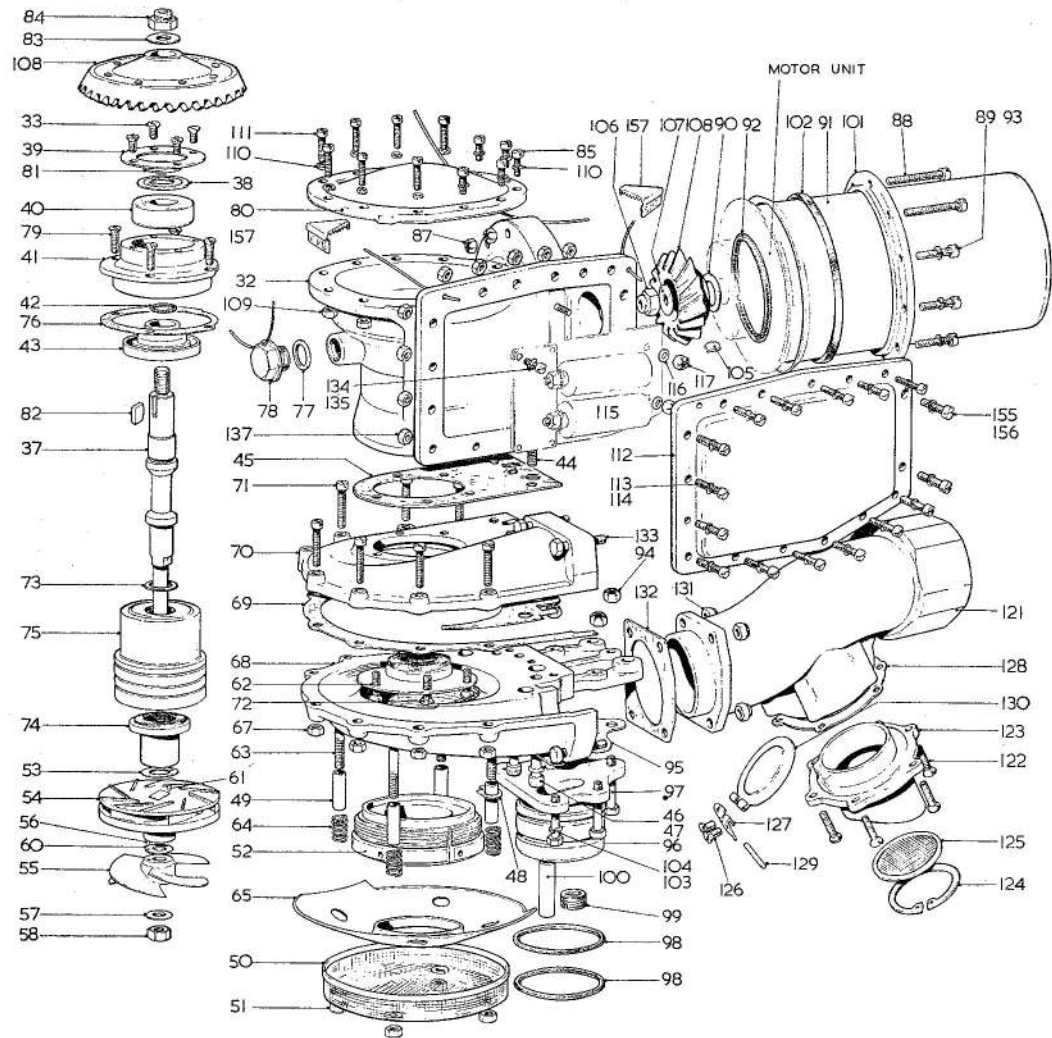

- |  |   |
|--|---|
| 32 PUMP BODY CASTING                           | 67 SELF-LOCKING NUT (VOLUTE ASSEMBLY)       |
| 33 C/SK. HD. SCREW (BEARING RET. PLATE FIXING) | 68 LOWER VOLUTE CASTING                     |
| 37 PUMP SHAFT (SPINDLE)                        | 69 VOLUTE GASKET                            |
| 38 BEARING DUST SHIELD                         | 70 UPPER VOLUTE CASTING                     |
| 39 BEARING RETAINER PLATE                      | 71 CHEESE HEAD SCREW (VOLUTE ASSEMBLY)      |
| 40 BALL BEARING                                | 72 C/SK. HD. SCREW (BASE BEARING HOUSING)   |
| 41 BEARING HOUSING                             | 73 BELLOWS GLAND LOADING SHIM               |
| 42 SEAL RING                                   | 74 BELLOWS SEAL BODY ASSEMBLY               |
| 43 BEARING THROWER SEAL                        | 75 BELLOWS HOUSING ASSEMBLY                 |
| 44 WIRE THREAD INSERT                          | 76 GASKET (BEARING HOUSING/PUMP BODY)       |
| 45 VOLUTE/PUMP BODY GASKET                     | 77 SEAL WASHER (DRAIN PLUG)                 |
| 46 SOCKET HEAD SCREW                           | 78 DRAIN PLUG                               |
| 47 SHAKEPROOF WASHER                           | 79 C/SK. HD. SCREW (BEARING HOUSING FIXING) |
| 48 HELIX SHROUD LOCKING TAB                    | 80 GEAR BOX COVER ASSEMBLY                  |
| 49 PILLAR (FILTER SUPPORT)                     | 81 BEVEL GEAR ADJUSTING SHIM                |
| 50 INLET FILTER                                | 82 DRIVE KEY                                |
| 51 FILTER SECURING SELF-LOCKING NUT            | 83 CLAMP WASHER                             |
| 52 HELIX SHROUD                                | 84 BEVEL GEAR SELF-LOCKING NUT              |
| 53 IMPELLER ADJUSTING SHIM                     | 85 CH. HD. SCREW (GEAR BOX COVER)           |
| 54 CENTRIFUGAL IMPELLER                        | 87 SELF-LOCKING NUT (MOTOR FIXING)          |
| 55 HELIX                                       | 88 CH. HD. SCREW (MOTOR FIXING)             |
| 56 DOWEL (IMPELLER TO HELIX)                   | 89 SHAKEPROOF WASHER (MOTOR FIXING)         |
| 57 CLAMP WASHER                                | 90 BEVEL PINION ADJUSTING SHIM              |
| 58 1/4 IN. B.S.F. SPINDLE END NUT              | 91 OUTER MOTOR CASING                       |
| 60 HELIX ADJUSTING SHIM                        | 92 O RING (MOTOR TO PUMP UNIT)              |
| 61 DOWEL (IMPELLER TO SEAL HOUSING)            | 93 CH. HD. SCREW (MOTOR FIXING)             |
| 62 BASE BEARING HOUSING ASSEMBLY               | 94 SELF-LOCKING NUT (LOCATING PLUG)         |
| 63 STUD (VOLUTE ASSEMBLY)                      | 95 LOCATING PLUG GASKET                     |
| 64 SPRING                                      | 96 LOCATING PLUG                            |
| 65 VAPOUR GUIDE CONE                           | 97 HEX. HD. BOLT (LOCATING PLUG FIXING)     |

Fig. 5. Exploded view of pump unit

~~RESTRICTED~~

## KEY TO FIG. 5—cont.

98	LOCATING PLUG SEAL RING
99	BREATHER PLUG ASSEMBLY
100	GLAND DRAIN TUBE
101	BOLT RING
102	SEAL RING (OUTER CASING JOINT)
103	SHAKEPROOF WASHER
104	HEX. HD. SCREW
105	DRIVE PIN
106	BEVEL PINION SELF-LOCKING NUT
107	CLAMP WASHER
108	BEVEL GEAR AND PINION (SUPPLIED AS PAIRED COMPONENTS)
109	SELF-LOCKING NUT (GEAR BOX COVER)
110	SPRING WASHER (GEAR BOX COVER)
111	CH. HD. SCREW (GEAR BOX COVER)
112	CAPACITOR COVER ASSEMBLY
113	CH. HD. SCREW (CAPACITOR COVER FIXING)
114	SPRING WASHER (CAPACITOR COVER FIXING)
115	CAPACITOR PANEL ASSEMBLY
116	PLAIN WASHER
117	SELF-LOCKING NUT (PANEL FIXING)
121	OUTLET CASTING
122	C/SK. HD. SCREW
123	BY-PASS VALVE HOUSING
124	CIRCLIP
125	FILTER
126	C/SK. HD. SCREW
127	HINGE PLATE
128	BY-PASS VALVE GASKET
129	HINGE PIN
130	VALVE PLATE
131	LOCKNUT
132	VOLUTE/OUTLET GASKET
133	HEX. HD. BOLT (OUTLET TO VOLUTE)
134	SPRING WASHER
135	CH. HD. SCREW (CAPACITOR PANEL TO PUMP CASTING)
137	NUT (CAPACITOR COVER FIXING)
155	CH. HD. SCREW (CAPACITOR COVER FIXING)
156	SPRING WASHER (CAPACITOR COVER FIXING)
157	LEAD SEAL

sembly (74) from the pump spindle using the extractor tool SPE.17373 (fig. 9), together with any shims fitted. Do not attempt to remove the carbon seal ring.

#### 12. Removing the bevel gear and upper bearing assembly.

(1) Holding the gear with special key SPE.17371 (fig. 9), unscrew and remove the self-locking nut and washer securing the bevel gear (108) to the shaft. Using the extractor tool SPE.17370 (fig. 9) withdraw the gear. Remove any shims (81) fitted and retain the drive key (82).

#### Note . . .

*If it is intended to re-use the gear, it must be paired with the pinion of the motor unit originally fitted to the pump unit. Re-use of the gear is not recommended.*

(2) Remove the four screws securing the upper ball race housing assembly to the pump casting. Break the seal washer (76) and withdraw the housing sub-assembly

complete, with the pump shaft in position. Take care not to damage the bellows unit when withdrawing the shaft through it.

(3) Remove the upper bearing dust shield (38). Withdraw the shaft through the bearing, tapping gently with a hide-faced hammer if necessary. Remove the bearing thrower seal (43) from the shaft and extract the seal ring (42).

(4) Remove the four screws securing the bearing retainer plate (39) to the housing. Press out the bearing (40).

#### 13. Removing the bellows housing assembly and ancillary fittings.

#### Note . . .

*The bellows gland unit need only be removed if the seal face is badly scored or if the seal is damaged in any way.*

(1) Pre-heat the pump casting to 125-150° C. Using the tools illustrated in fig. 10 press out the bellows sub-assembly housing (75). Do not attempt to remove the bellows unit from the housing.

(2) Remove the drain plug (78) and the drain plug washer.

#### Dismantling the motor unit

#### 14. Disconnecting the field leads and removing the brushes.

(1) Remove the four screws and shakeproof washers securing the brush assemblies (24). Release the field leads and remove the brushes after identifying each with its corresponding brush box. This will ensure that the brushes, if refitted for a further period of service, are returned to their original boxes.

#### 15. Removing and dismantling the commutator-end motor casing.

(1) Hold the bevel pinion to prevent the motor spindle turning, and unscrew and remove the commutator end bearing nut (17). Unscrew and remove the tie-bolt nuts (12) and washers and withdraw the tie-bolts (10) through the motor assembly.

(2) Carefully detach the commutator end motor casing (9) from the stator assembly. Use a hide faced hammer to gently tap free if necessary. Take care not to scratch the commutator on the brush holders when withdrawing the casing assembly. Separ-

~~RESTRICTED~~

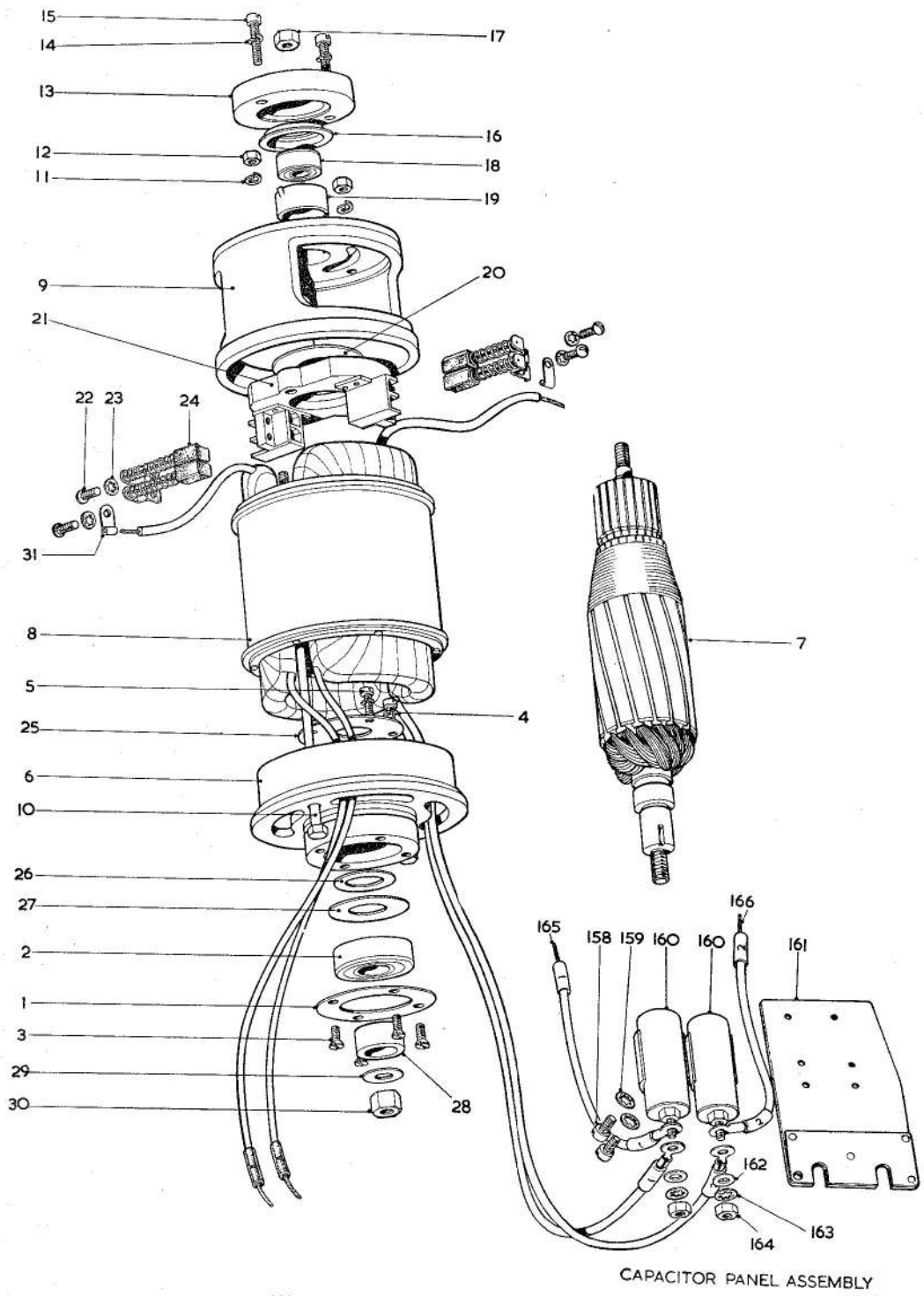

CAPACITOR PANEL ASSEMBLY

Fig. 6. Exploded view of motor unit

~~RESTRICTED~~

## Key to fig. 6

- |    |                                      |                            |
|----|--------------------------------------|----------------------------|
| 1  | BEARING RETAINER PLATE               |                            |
| 2  | BALL BEARING                         |                            |
| 3  | C/SK.HD. SCREW                       |                            |
| 4  | SPRING WASHER                        | } SEAL WASHER<br>ATTACHING |
| 5  | CHEESE HD. SCREW                     |                            |
| 6  | FRONT MOTOR CASING                   |                            |
| 7  | ARMATURE ASSEMBLY                    |                            |
| 8  | STATOR ASSEMBLY                      |                            |
| 9  | COMMUTATOR-END MOTOR CASING          |                            |
| 10 | TIE-BOLT                             |                            |
| 11 | TIE-BOLT PLAIN WASHER                |                            |
| 12 | TIE-BOLT NUT                         |                            |
| 13 | BRUSH BOX RETAINER                   |                            |
| 14 | SPRING WASHER                        |                            |
| 15 | BRUSH BOX SECURING SCREW             |                            |
| 16 | BEARING COVER PLATE                  |                            |
| 17 | $\frac{1}{4}$ IN. B.S.F. BEARING NUT |                            |
| 18 | COMMUTATOR END BALL BEARING          |                            |
| 19 | BEARING SLEEVE                       |                            |
| 20 | DUST SHIELD                          |                            |
| 21 | BRUSH BOX ASSEMBLY                   |                            |
| 22 | RD. HD. SCREW (BRUSH SECURING)       |                            |
| 23 | SHAKEPROOF WASHER (BRUSH SECURING)   |                            |
| 24 | BRUSH AND TAG ASSEMBLY               |                            |
| 25 | SEAL WASHER                          |                            |
| 26 | FLOATING WASHER                      |                            |
| 27 | DUST SHIELD                          |                            |
| 28 | SPECIAL SPACER BUSH                  |                            |
| 29 | CLAMP WASHER (PLAIN)                 |                            |
| 30 | LOCKNUT                              |                            |

ate the stator assembly (8) from the front motor casing (6) by withdrawing it carefully over the armature.

**Note . . .**

*Do not attempt to remove the field coils from the stator assembly.*

(3) Unscrew and remove the two brush box securing screws (15) and spring washers. Remove the brush box assembly (21), retainer (13), bearing cover plate (16) and dust shield (20). Press the bearing (18) and sleeve (19) out of the casing, and separate the bearing from the sleeve using the special tools illustrated in fig. 11.

**16. Dismantling the drive-end motor casing.**

(1) Remove the pinion securing nut (106), together with the clamp washer bevel pinion (108) and shims. Retain the driving key (105).

(2) Remove the four screws (3) securing the bearing retainer plate to the casing (6), together with the four screws (5) and the spring washers attaching the seal washer (25). Press the bearing out of the housing together with the floating washer (26) and the dust shield (27).

**Note . . .**

*If the pinion is to be re-used, ensure that it is paired with the gear removed from the associated pump unit.*

**CLEANING, INSPECTION AND REPAIR****Cleaning**

17. Immerse the armature and field assembly in white spirit and use a soft bristle brush to dislodge carbon deposits, etc. After cleaning both the armature and field assembly blow off the surplus spirit and allow them to dry out for several hours. Complete the drying in an oven at approximately 93°C. Ensure that all dried jointing compound is removed from the mating pump component surfaces, using any available approved remover if necessary. All parts, excepting the electrical connections, bearings, and synthetic material or rubber components should be cleaned in a dry-cleaning solvent, or if excessively dirty, in a heavy duty degreasant. After cleaning allow them to dry out for 12 hours and complete the drying in an oven at approximately 93°C.

**Inspection**

18. *General:* Inspect all metal components for cleanliness, distortion, cracking (visual), scoring, denting, visual evidence of wear, deterioration of protective finishes (corrosion), serviceability of threads, security of sub-assemblies not dismantled (riveting, etc.), and discolouration due to over-heating. Examine re-usable rubber components and electrical cable insulation for cleanliness, chafing, cracking, cuts, overheating, fluid soakage and general deterioration. All seal rings must be renewed on re-assembly. It is also recommended that bearings and paired gear and pinion assemblies should be renewed at each overhaul.

**~~RESTRICTED~~**

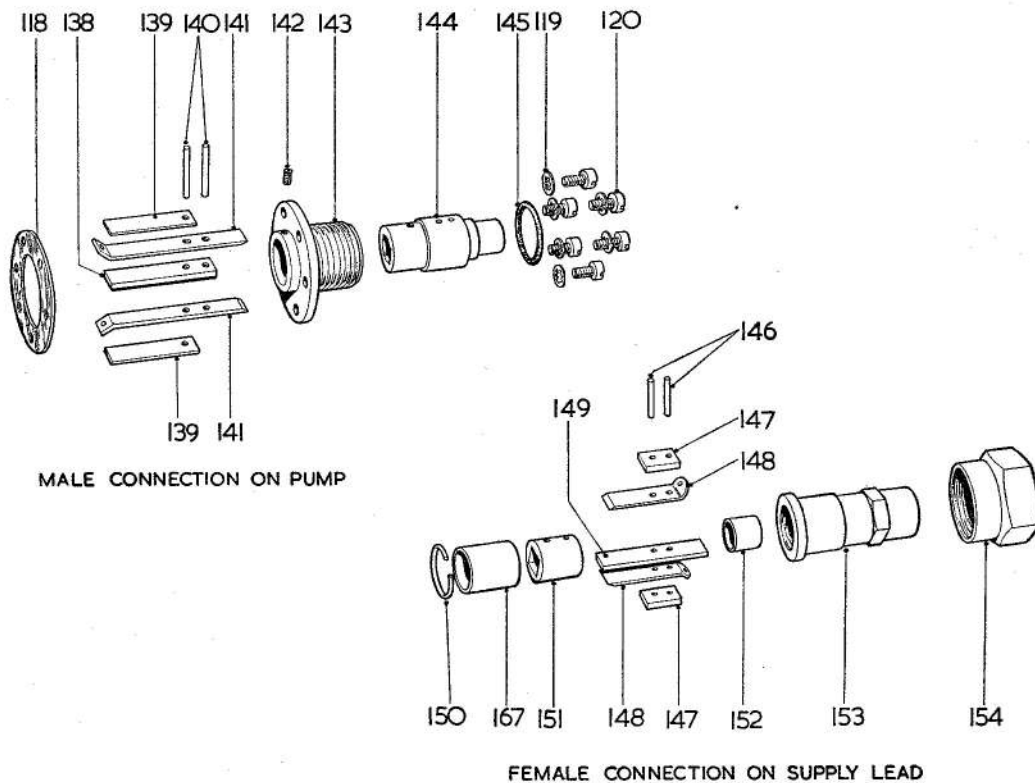

- 118 ELECTRICAL CONNECTION GASKET
- 119 SHAKEPROOF WASHER
- 120 CH. HD. SCREW (ELECTRICAL CONNECTION FIXING)
- 138 INSULATION PLATE
- 139 INSULATION STRIP
- 140 LOCKING PIN
- 141 CONTACT PLATE
- 142 GRUBSCREW
- 143 FLANGED HOUSING
- 144 INSULATION BODY
- 145 O RING
- 146 LOCKING PIN
- 147 OUTER INSULATION PLATE
- 148 CONTACT PLATE
- 149 CENTRAL INSULATION PLATE
- 150 CIRCLIP
- 151 LOCKING BUSH
- 152 INSULATION BUSH
- 153 SOCKET BODY
- 154 UNION NUT
- 167 INSULATION BUSH

**Fig. 7. Exploded view of electrical connection**

19. Detailed procedure: Parts should be inspected in accordance with Table 2 and checked for conformity with the Schedule of Fits, Clearances and Repair Tolerances given in Table 3.

~~RESTRICTED~~

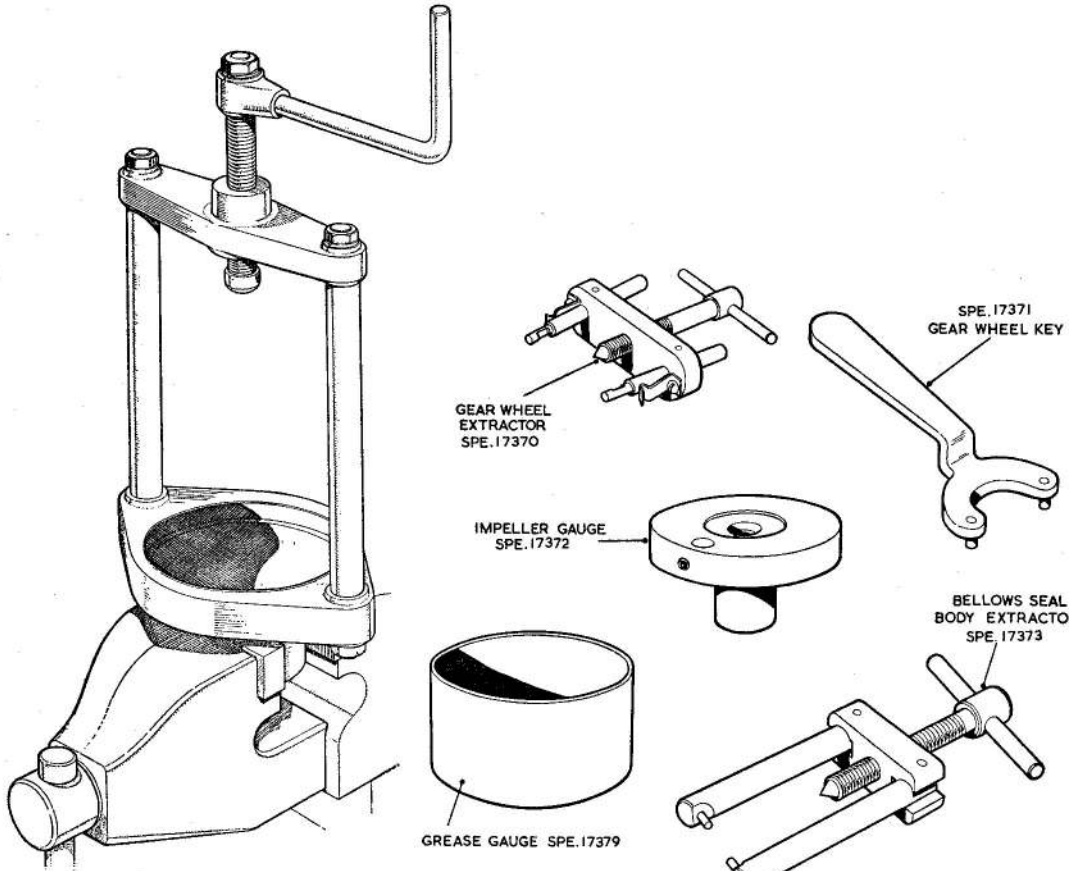

Fig. 8. Hand press

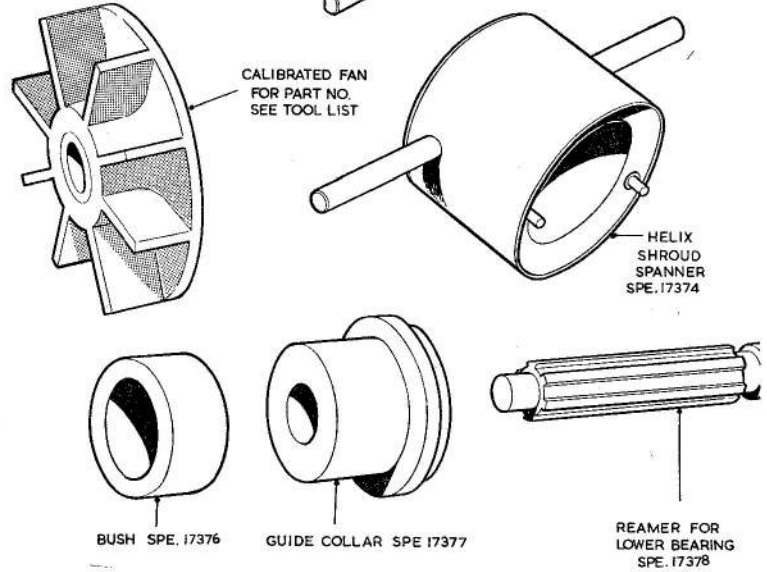

Fig. 9. General tools

~~RESTRICTED~~

Table 2

## Detailed inspection of components

Item	Inspection	Action if faulty
Armature	Insulation resistance to shaft. Use a 500 volt insulation resistance tester	Clean thoroughly using white spirit. Dry for prolonged period at 93° C. Allow armature to cool. Check that the insulation resistance reading is not less than 50 megohms. If below this figure continue drying process. Cool. Recheck.
	Commutator for loose conductors.	Reject for re-winding.
	Commutator for scoring and burnt segments.	Skim commutator. Minimum permissible diameter for further use is 24.0 mm. (0.945 in.) Undercut mica 0.5 mm. deep $\times$ 0.036 in. wide if necessary. Check that no copper burrs are shorting across mica between segments. Commutator to be true with spindle to within 0.001 in. total clock reading when running on journals.
	Fouling of armature on poles.	Check spindle for concentricity and side-play of bearings.
	Short or open-circuited conductors. Use voltage drop tester or growler.	Clean undercutting of mica between segments of commutator. Remove copper burrs. If still unsatisfactory, reject armatures.
	Armature spindle for concentricity.	Maximum eccentricity 0.025 mm. (0.001 in.). If excessive, reject.
Field	Charring or other evidence of overheating.	Renew complete assembly.
	Total resistance of windings measured and corrected to 15°C. Shunt 186.2 to 205.8 ohms. Series 0.060 to 0.033 ohms.	Renew complete assembly.
	Condition of field coils.	If damaged, renew complete assembly.
	Insulation resistance of coils to frame.	Clean thoroughly using white spirit ( <i>para.</i> 16). Dry for prolonged period at 93° C. Allow to cool. Check that the insulation resistance reading is not less than 50 megohms. If below this figure continue drying process. Cool. Recheck.
	Condition of field coil lead covering.	If damaged, cover with additional sleeving.

~~RESTRICTED~~

TABLE 2—cont.

Item	Inspection	Action if faulty
Brush gear	Brushes for wear.  Examine brush pig-tail leads for fraying and looseness in brush carbon.  Fit of brush in brush boxes.	See Fits and Clearances (Table 3)  Renew brushes.  Brushes should slide freely in brush boxes. Carbon collected in corners of brush boxes should be removed.
Bearings	It is recommended that new ball bearings are fitted at each overhaul of the pump.	
Metallic bellows gland	Scoring of seal faces.  Damage to bellows unit convolutions.	If slight, relap to a mirror finish. If excessive, renew. Renew unit.
Plain carbon bearing (pump) (unit)	Damaged or cracked carbon.  Excessive wear.	Renew bearing housing assembly complete.  Renew bearing housing assembly complete.
Gaskets and joint rings.	Renew at each overhaul.	Renew.
By-pass flap valve	Scored or damaged seal face.  Worn pivot.	Renew.  Renew pin and valve components as necessary.
Seal body	Scoring of carbon seal face and wear.  Examine carbon for signs of cracks, damage or specks of metal, indicating partial seizure on sealing face.	If slight relap to a mirror finish. If excessive, renew.  Renew assembly.
Filter	Damaged wire mesh	Renew.
Suppressor units	Each suppressor should be individually checked with a 250 volt constant pressure insulation resistance tester. Insulation resistance between terminal and earth to be not less than 50 megohms.	Renew.

~~RESTRICTED~~

TABLE 2—cont.

Item	Inspection	Action if faulty
Bevel gear and pinion.	It is recommended that a new gear and pinion are fitted at each overhaul of pump. If components have to be re-used, it is essential that parts are kept together when dismantling and rebuilt into same pump assembly with identical meshing.	
Commutator end casing assembly	Security of stainless steel end frame.	Renew casing assembly.

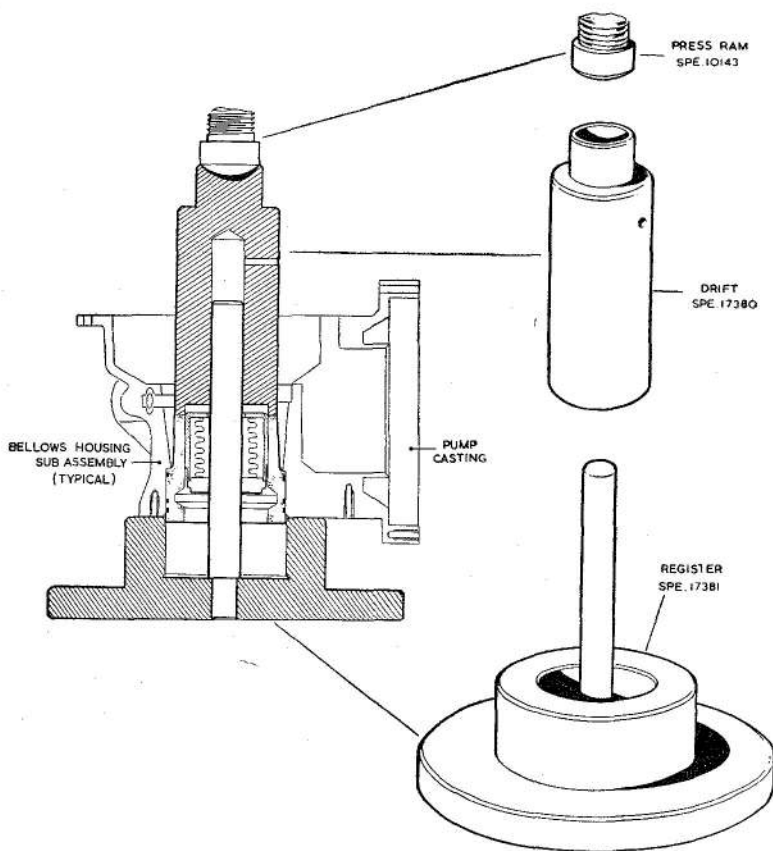
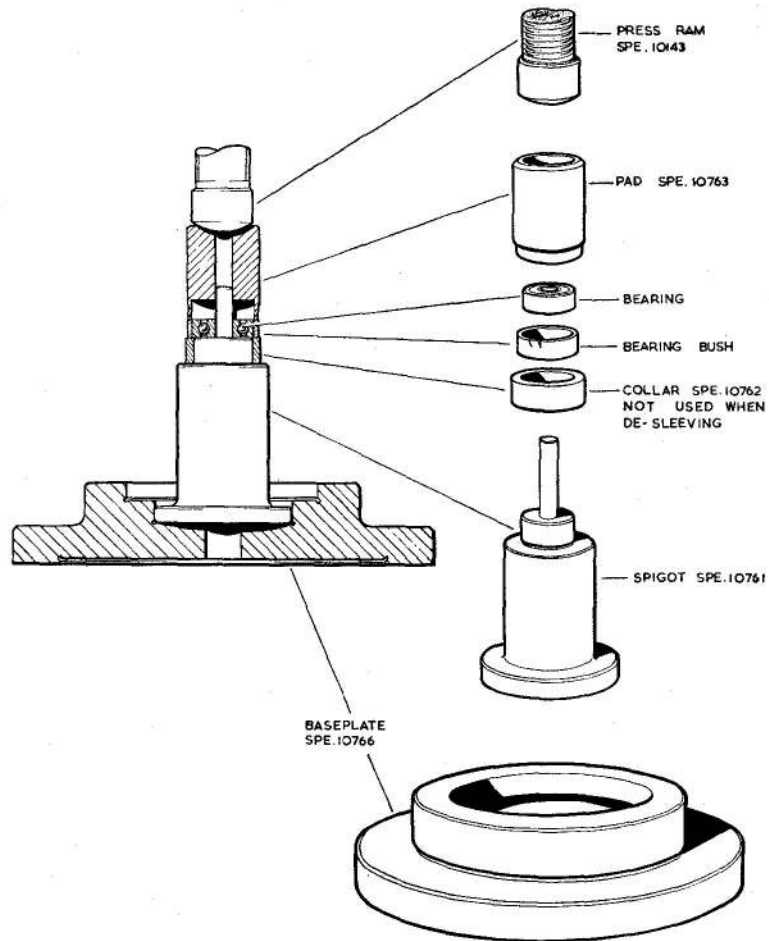

Fig. 10. Bellows housing removal

~~RESTRICTED~~



**Fig. 11. Bearing sleeve removal and assembly**

~~RESTRICTED~~

~~RESTRICTED~~

Table 3  
SCHEDULE OF FITS, CLEARANCES AND REPAIR TOLERANCES

Part and Description	Dimensions New	Permissible worn dimension for re-use	Clearance New	Permissible worn clearance for re-use	Remarks
MOTOR UNIT BRUSH LENGTH	11.8 mm (0.465in)	10.6 mm (0.417in)	—	—	Brush length reduces approx. 0.010in. in 500 hours.
COMMUTATOR  Diameter	{ 25.1 mm 24.9 mm (0.988in) (0.98in)	24.0 mm (0.945in)	—	—	
ARMATURE END FLOAT	—	—	0.125 mm (0.005in) max	0.2 mm (0.008in) max	—
ARMATURE SPINDLE IN DRIVE END BALL RACE  Diameter	{ 11.995 mm 11.985 mm (0.4723in) (0.4719in)	—	—	—	Inner race clamped to spindle on both faces. Selective assy.
Bore	{ 12.0 mm 11.990 mm (0.4724in) (0.4721in)				

Table 3—cont.

## SCHEDULE OF FITS, CLEARANCES AND REPAIR TOLERANCES

Part and Description	Dimensions New	Permissible worn dimension for re-use	Clearance New	Permissible worn clearance for re-use	Remarks
ARMATURE SPINDLE IN COMMUTATOR END BALL RACE					Inner race clamped to spindle on both faces. Selective assy.
Diameter	$\left\{ \begin{array}{l} 5.995 \text{ mm} \\ 5.985 \text{ mm} \\ (0.237\text{in}) \\ (0.23\text{in}) \end{array} \right.$	—	—	—	
Bore	$\left\{ \begin{array}{l} 6.0 \text{ mm} \\ 5.990 \text{ mm} \\ (0.2362\text{in}) \\ (0.235\text{in}) \end{array} \right.$				
COMMUTATOR END BEARING SLEEVE IN MOTOR CASING					
Diameter	$\left\{ \begin{array}{l} 20.59 \text{ mm} \\ 20.58 \text{ mm} \\ (0.8106\text{in}) \\ (0.8102\text{in}) \end{array} \right.$		$\left\{ \begin{array}{l} 0.02 \text{ mm} \\ 0.04 \text{ mm} \\ (0.0008\text{in}) \\ (0.0016\text{in}) \end{array} \right.$	$\left\{ \begin{array}{l} 0.04 \text{ mm} \\ (0.0016\text{in}) \end{array} \right.$	
Bore	$\left\{ \begin{array}{l} 20.61 \text{ mm} \\ 20.62 \text{ mm} \\ (6.8114\text{in}) \\ (0.8118\text{in}) \end{array} \right.$				

~~RESTRICTED~~

~~RESTRICTED~~

Table 3—cont.

SCHEDULE OF FITS, CLEARANCES AND REPAIR TOLERANCES

Part and Description	Dimensions New	Permissible worn dimension for re-use	Clearance New	Permissible worn clearance for re-use	Remarks
<b>PUMP UNIT</b> PUMP SHAFT IN UPPER BALL RACE  Diameter       Bore	$\left\{ \begin{array}{l} 11.995 \text{ mm} \\ \hline 11.985 \text{ mm} \\ (0.4723\text{in}) \\ \hline (0.4719\text{in}) \end{array} \right.$  $\left\{ \begin{array}{l} 12.0 \text{ mm} \\ \hline 11.990 \text{ mm} \\ (0.4724\text{in}) \\ \hline (0.4721\text{in}) \end{array} \right.$	—	—	—	Inner race clamped to spindle on both faces. Selective assy.
BELLOWS SEAL BODY Diameter IN CARBON BEARING     Bore	$\frac{0.7475\text{in}}{0.747\text{in}}$  $\frac{0.751\text{in}}{0.750\text{in}}$	0.747in  0.751in	$\frac{0.0025\text{in}}{0.004\text{in}}$	0.004in	Free running shaft component in supported bearing
IMPELLER TO LOWER BEARING HOUSING ASSY (Dim. A. Fig. 12)	—	—	0.005in		Adjust clearance as detailed in para. 34

Table 3—cont.

SCHEDULE OF FITS, CLEARANCES AND REPAIR TOLERANCES

Part and Description	Dimensions New	Permissible worn dimension for re-use	Clearance New	Permissible worn clearance for re-use	Remarks
PROJECTION OF HELIX BLADES BELOW MOUTH OF HELIX SHROUD (Dim. B. Fig. 12)	—	—	1.0 mm (0.0394in)		Adjust as detailed in para. 34
Clearance between tips of helix blades and mouth of vapour guide cone (Dim. C. Fig. 12)	0.75 mm	—	—	—	—
	1.00 mm				
	(0.0295in)				
	(0.0394in)				

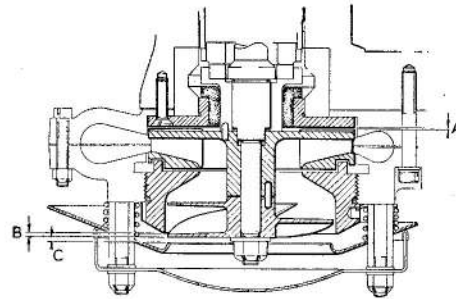

Fig. 12. Impeller, helix and vapour guide cone clearances

~~RESTRICTED~~

## ASSEMBLING

### General

20. Preserve absolute cleanliness of the work-bench and tools throughout the assembly of the pump. Retain the bearings in their wrappings until they are required for assembly. Always use the special tools provided where specified.

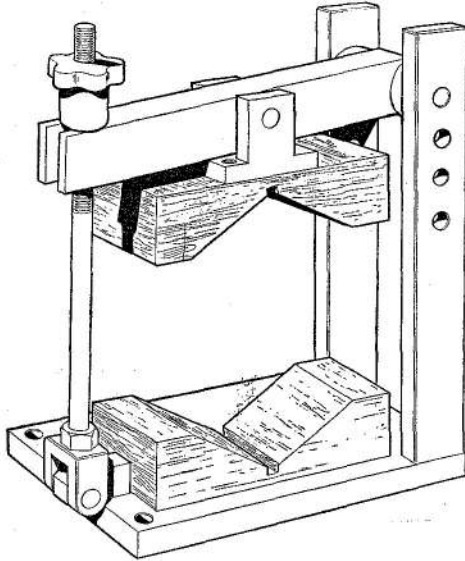

Fig. 13. Motor unit clamp

### Motor unit

#### 21. Assembling the drive end motor casing.

(1) Pre-select a new bearing (2) that is a slide fit under thumb pressure both on the armature spindle (7) and in the motor casing (6). Retain the armature assembly and end casing and suitably mark both so that they can be paired with selected bearing at a later assembly stage. Check that the selected bearing is smooth running with no roughness when the inner race is rotated by hand.

(2) Check that the bearing housing in the end casing (6) is perfectly clean and that the wall surface is smooth and free of score marks, burrs, and adhering swarf. Fit bearing shield (27) with dished side uppermost into the bearing housing and insert the selected bearing.

(3) Fit the bearing retainer plate (1) over the bearing and secure with four c./sk.hd. screws (3).

(4) Fit floating washer (26) in the recess behind the bearing housing, followed by seal washer (25), and secure both with screws (5) and spring washers (4).

#### 22. Assembling the upper bearing and sleeve

(1) Pre-select an upper bearing (18) which is a slide fit under thumb pressure on the selected armature spindle (*para.* 21). Check that the bearing is smooth running with no roughness when the inner race is rotated by hand.

(2) Assemble the selected bearing (18) into the steel sleeve (19) using the special tools illustrated in fig. 11.

(3) Fit the bearing and sleeve assembly into the commutator end motor casing (9). Ensure that the ears of sleeve (19) locate in the motor casing slots to prevent rotation of the assembly in its housing.

#### 23. Assembling the brush box.

(1) Fit dust shield (20) in the recess at the back of the brush box assembly (21) and retain it with a minimum quantity of Boscprene or other approved rubber cement. Wipe off any excess.

(2) Hold the brush box assembly in position inside the motor casing (9). Fit bearing cover (16) over the upper bearing and replace the brush box retainer (13). Secure the retainer and brush box with two screws (15) and spring washers (14). Centralise the brush box assembly about the bearing and tighten screws. A final adjustment will be made during the speed setting.

#### 24. Assembling the armature to drive end motor casing assembly.

(1) Enter armature (7) previously used to check bearing fits, through the bore of the assembled drive-end bearing (*para.* 21).

(2) Retain the armature with the special spacer bush (28), washer (29) and nut (30). A scrap pinion (108) can be used in place of the spacer bush (28) if available.

#### 25. Fitting the drive end motor casing and armature assembly to stator and commutator end motor casing assembly.

(1) Carefully insert the armature assembly through the bore of the stator assembly (8) from the four lead end. Thread the leads through the adjacent motor end casing slots and locate the casing on the stator spigot. Positively locate by engaging stator pin in casing rim.

(2) Carefully position the commutator end frame sub-assembly over the armature, guide the shaft into the upper bearing and positively locate the frame by engaging the stator pin in the casing rim slot.

**RESTRICTED**

**Note . . .**

Take great care not to scratch the commutator on the brush boxes during assembly.

(3) Insert tie-bolts (10) through the drive end casing, stator and commutator end casing. Secure the bolts to end frame with nuts (12) and washers (11), tightening each in turn. Tap round the casing joints to the stator assembly with a hide-faced hammer whilst tightening to ensure a perfect seating.

(4) Hold the drive-end spindle nut with a spanner and replace spindle nut (17). Securely tighten the spindle nut against the inner race of the bearing.

**26. Pre-bedding of brushes.**

(1) Preferably using a slave motor, insert a brush (24) into each of four brush boxes, retaining each with screws (22).

(2) With a strip of fine grade glass paper wrapped round the commutator turn the armature by hand until the brushes are bedded over their full width of arc.

**27. Preliminary brush bedding motor run.**

(1) Remove the brushes from the brush boxes of the slave motor, clean the faces with a small brush and transfer them to the motor unit being assembled. If the original brushes are being refitted facilitate rebedding by returning them to their

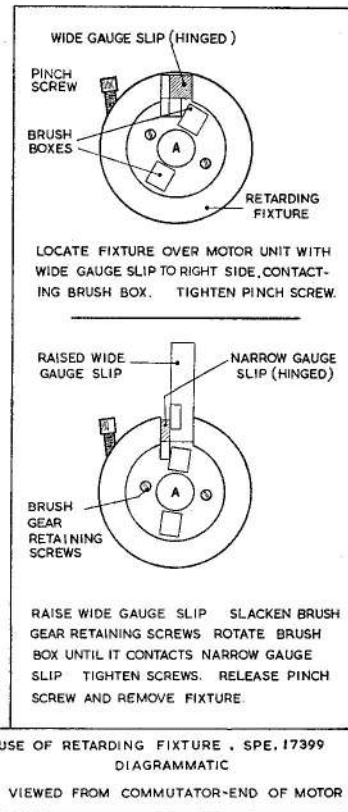
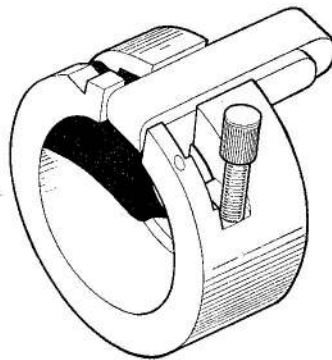
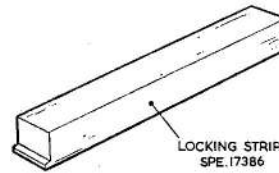
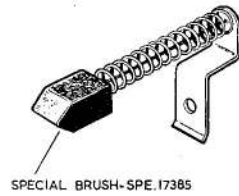

**Fig. 14. Brush gear retarding fixture**

~~RESTRICTED~~

original boxes, as indicated by the marking made on disassembly.

(2) Secure the brushes with screws (22) and shakeproof washers (23), connecting a field coil lead tag to the first brush of each pair.

(3) Run the motor unit at 20-22 volts d.c. without load and with the brush gear set in a position giving minimum sparking at the commutator for approximately three hours or until the brushes bed over their full width of arc.

(4) Identify all the four brushes with their corresponding brush boxes, and remove each of them from their boxes.

### 28. Motor speed setting.

(1) The motor speed should now be set by retarding the brush gear from its geometric neutral axis by 10.5 degrees ( $\pm 4.5$  degrees). To determine the geometric neutral axis proceed as follows.

(2) Isolate the field coils from the brush boxes and insert one special brush SPE.17385 (fig. 14) in the first of each pair of brush holders. Secure each with screw (22) and shakeproof washer (23). Do not connect the field leads. Clamp the motor unit in a bench clamp, similar to that illustrated in fig. 13, to facilitate brush setting and retardation.

#### Note . . .

The special brushes used can be made from a standard brush (24). The end is shaped as illustrated in fig. 14 so that the brush contacts one segment of the commutator only.

(3) With a locking strip SPE.17386 (fig. 14), lock the brush gear and armature. This strip should be inserted in an unused brush box with the end ridge located in a commutator slot. Hold the locking strip in position.

(4) Use one of the following methods to determine the geometric neutral position

(a) Connect up the circuit as follows:

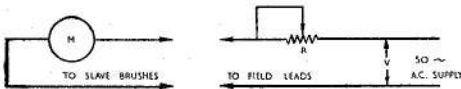

Fig. 15. Brush gear setting, circuit diagram 1

V: 20 volts maximum

M: Low reading a.c. millivoltmeter or microammeter.

R: Variable swamp resistor to limit pointer deflection to maximum scale reading.

Slacken the brush gear securing bolts, and rotate the brush box until a zero reading is obtained on the meter (M). Continue the rotation until the meter reading increases, reverse the direction of rotation and continue until a true zero reading is obtained. Do not release the hold on the locking strip during this operation.

Mark the relative position of the brush box carrier to the commutator end motor casing.

(b) Alternative method: Connect up circuit as follows:

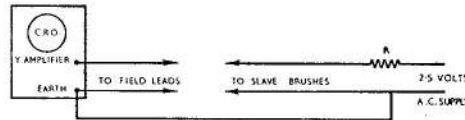

Fig. 16. Brush gear setting, circuit diagram 2

R: 3 ohm wire wound resistor.

Switch the oscilloscope time base to a frequency much higher than the 2.5-volt supply frequency, so that a rectangular trace is obtained on the cathode ray tube.

Slacken the brush gear securing bolts and rotate the brush gear and armature carefully so that the trace attains a maximum amplitude (vertical displacement) or overload. If the overload trace is not obtained, set the "Y" amplifier at full gain. Leave the oscilloscope at this setting

Rotate the brush gear and armature until the narrowest possible horizontal line appears on the cathode ray tube. Continue rotating until the width of the line increases, reverse the direction of rotation and continue until the narrowest possible line is obtained.

Mark the relative position of the brush box carrier to the commutator end motor casing.

(5) Rotate the armature through 90 degrees and determine the geometric

~~RESTRICTED~~

neutral axis at the new position by the method in, para. 28, sub-para. 4(a) or (b). Mark the motor casing in line with the original datum on the brush box carrier. Repeat the method twice more at 90 degree intervals of commutator/armature relationship. Align the original datum mark on the brush box carrier with the mean of four marks on the motor casing. Tighten the brush box securing bolts. Remove the locking strip and the special brushes.

(6) Position the retarding fixture SPE. 17387 (fig. 14), over the motor unit so that viewed from the commutator end, the wider of the two hinged gauge slips is on the right-hand side. Locate the fixture completely over the commutator end casing. Lower the hinged gauge slips and rotate the fixture until the wider slip contacts the side of a brush box. Tighten pinch screws.

(7) Raise the wide gauge slip, and slacken the brush box securing screws. Rotate the brush box assembly in an anti-clockwise direction, until it contacts the narrow gauge slip. Tighten the brush box securing screws.

#### Caution . . .

*Ensure that pinch screw of retarding fixture is well tightened and that there is no change of motor unit/retarding fixture relationship while adjusting brush box position.*

Remove the retarding fixture.

(8) Return the brushes, removed after the preliminary brush bedding motor run (para. 28(4)) to their original boxes as indicated by markings. Secure the brushes with roundhead screws (22) and shake-proof washers (23), connecting a field coil lead to the first brush of each pair.

(9) Run the motor unit without load for a minimum period of 10 hours at 18 volts d.c. input. After this run, remove and examine each brush. The brushes must bed over their full width of arc with at least 80 per cent. of their face area making contact with the commutator. Running is to be repeated as required until this condition is achieved for all brushes.

#### Caution . . .

*Ensure that the brushes are returned after examination to the brush box in which they were initially fitted.*

(10) Instal the motor unit in a tank recess surrounded by a suitable coolant maintained at 20 to 25° C. (It is suggested that an outer motor casing (91) is set into the side wall of a tank and the motor unit clamped into position). Using the calibrated fan SPE.17398 (fig. 9) or a suitable dynamometer apply a torque of 24 oz. inches to the motor unit. Run the motor unit under load for 30 minutes at 26 volts d.c. input. Check that this speed is  $9,800 \pm 100$  r.p.m., and the current consumption, which should not exceed 11.5 amps.

(11) Adjustment of the brush box is permissible to the extent of 4.5 degrees only, either way. Where adjustment is required in excess of 4.5 degrees the motor should be rejected.

#### Note . . .

*4.5 degrees movement of the brush box represents an 0.091 in. (2.3 mm) movement measured on the outside diameter of the brush box carrier (21).*

Repeat the speed check after any adjustment.

(12) When the speed is correctly set apply air drying varnish to the brush box carrier inserts and to the ends of the carrier retainer screws (15).

(13) Remove the motor unit from the tank fixture and while it is running under load make a visual check for absence of sparking at the brushes. Check the insulation resistance of the motor unit while warm, using a 500 volt insulation resistance tester. The insulation resistance must not be less than 10 megohms.

#### Pump unit

##### 29. Reaming the carbon bearing.

(1) Using a pump casting without a bellows housing sub-assembly (75) fit the lower bearing housing assembly (62) and secure it with five screws (72). Lubricate the carbon with kerosene fuel. Using the special reamer SPE.17378 with guide bush SPE.17376 and collar SPE.17377 (fig. 9)

~~RESTRICTED~~

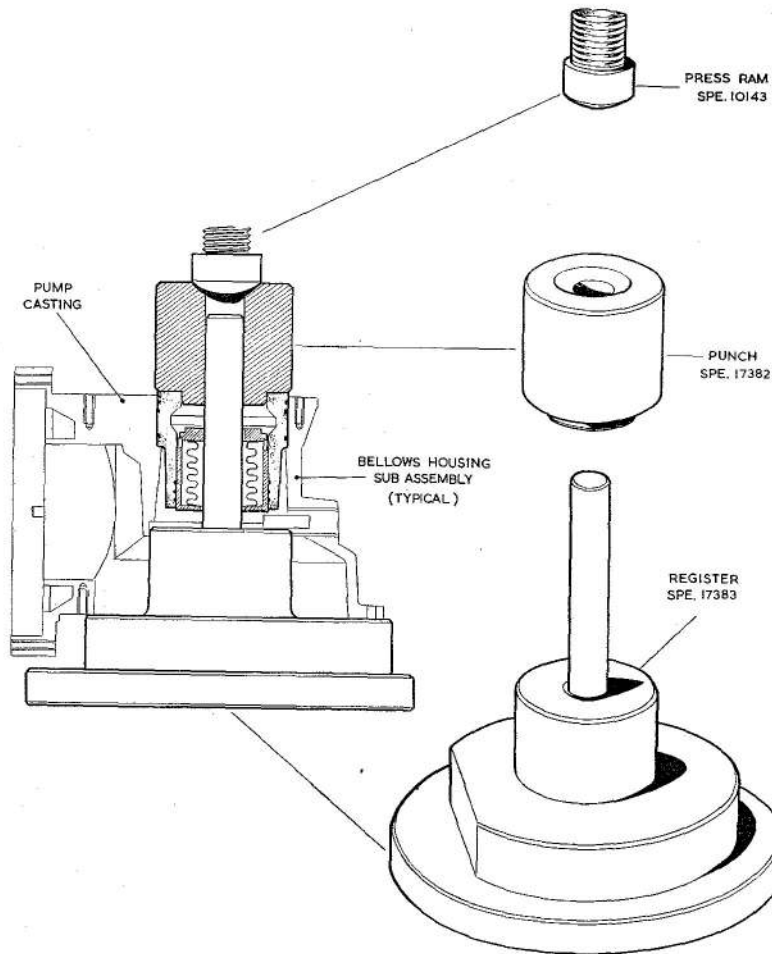

Fig. 17. Bellows housing assembly

ream the bearing to size:  $0.750 \text{ in. } \begin{matrix} +.001 \\ -0 \end{matrix} \text{ in.}$

Take great care not to chip the carbon.

(2) Mark the lower bearing housing assembly and the pump casting to ensure that they are both assembled into the same pump unit, and that they bear the same positional relationship at a later stage. Remove the bearing housing.

**30. Assembling the bellows unit sub-assembly.**

(1) Pre-heat the pump casting to approximately  $250\text{-}300^{\circ} \text{ C.}$  Smear the lower portion of the housing assembly (75) with Hermeticoll jointing compound and using the tools illustrated in fig. 17, press the housing into position until the shoulder abuts with that in casting. Wipe off any exuded jointing compound.

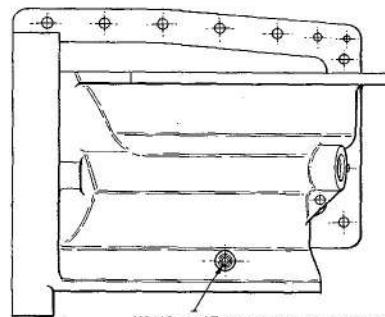

USING EXISTING HOLES IN CASTING DRILL THROUGH No. 44 (.086" DIA.). CARE MUST BE TAKEN TO SEE THAT NO DAMAGE IS DONE TO THE BELLOWS WHEN BREAKING THROUGH

Fig. 18. Bellows unit lubrication holes

~~RESTRICTED~~

(2) Using existing tapped holes in casting as a guide, drill through the bellows housing with a No. 44 (0.086 in. dia.) drill, taking care not to damage the bellows unit (fig. 18).

**Note . . .**

*These holes ensure fuel access to the seal unit faces for lubrication purposes.*

(3) Use compressed air to ensure that no swarf from the drilled holes has been trapped in the bellows unit convolutions.

(4) Paint the mating surfaces of the pump casting (32) and volute assembly (66) with Wellseal jointing compound. Fit gasket (45) and secure the volute assembly with three socket-head screws (46) and shake-proof washers (47).

**Note . . .**

*If the volute assembly was completely dismantled, re-assemble using the original paired upper and lower volute castings ((68) and (70)). Fit a new gasket (69) after smearing the mating surfaces with Wellseal jointing compound. Assemble the castings with the seven screws (71) inserted from the top side and secure with self-locking nuts (67). Replace any damaged studs (63) in the lower volute casting.*

**31. Shaft component checking.**

(1) Pre-select a bearing (40) that is a slide fit under thumb pressure both on the pump shaft (37) and in bearing housing (41). Retain the shaft and housing and mark both so that they can be paired with the selected bearing and built into the same pump unit at a later assembly stage. Check that the selected bearing is smooth running with no roughness when the inner race is rotated by hand.

(2) Check that bearing housing is perfectly clean and that the wall surface is smooth and free of score marks, burrs, adhering swarf, etc. Insert the selected bearing. Assemble retaining plate (39), securing with four screws (33). Peen metal into slots of the screws to lock.

(3) Fit bearing thrower seal (43), bearing housing sub-assembly (*para.* 31 (2)), bellows seal body (74), centrifugal impeller (54) and helix (55) to the selected shaft in the correct assembly order.

Inspect the fit of components on the shaft, ensure that all components will tighten flush against the shaft shoulders. Retain all the components for assembly into the same pump unit.

**32. Upper bearing housing assembly.**

(1) Fit new seal ring (42) in the internal groove of the bearing thrower seal (43).

(2) Lubricate the seal ring with a smear of Silicone MS 4 compound A.339 Ref. No. 33C/9424829 and position the thrower seal on the shaft.

(3) Locate the shaft through the bore of the selected bearing. Smear the mating surfaces of the ball race housing and pump casting with Wellseal jointing compound, position new gasket (76) and carefully insert the shaft sub-assembly through the bellows unit. Secure the housing assembly with four screws (79). Peen metal into slots of the screws to lock.

(4) Position the upper bearing dust shield (38) and retain with temporary distance piece (34), washer (36) and locknut (35). If a distance piece (34) is not available fit a scrap bevel gear (108).

**33. Determination of correct bellows loading.**

(1) Place bellows seal body assembly (74) in position on pump shaft. Using the tools illustrated in fig. 9, determine the thickness of shims (73) required to give the bellows unit correct loading of 18 ounces. Proceed as follows:—

(a) Place an 18-ounce weight (SPE. 17388) over the shaft and locate it about the seal body.

(b) Swing the clock gauge into position and register it on a point close to the central hole through the weight. Set the gauge to zero.

(c) Fully depress the weight by finger pressure and note the new reading on the clock gauge. The difference between the two readings (+0.020 in. to allow for compression on final assembly), gives the thickness of the shim required.

(d) Select shims (73) of correct total thickness, lightly smear with jointing compound and fit on pump spindle. Lubricate carbon seal face of seal body (74) with a drop of kerosene and refit.

**~~RESTRICTED~~**

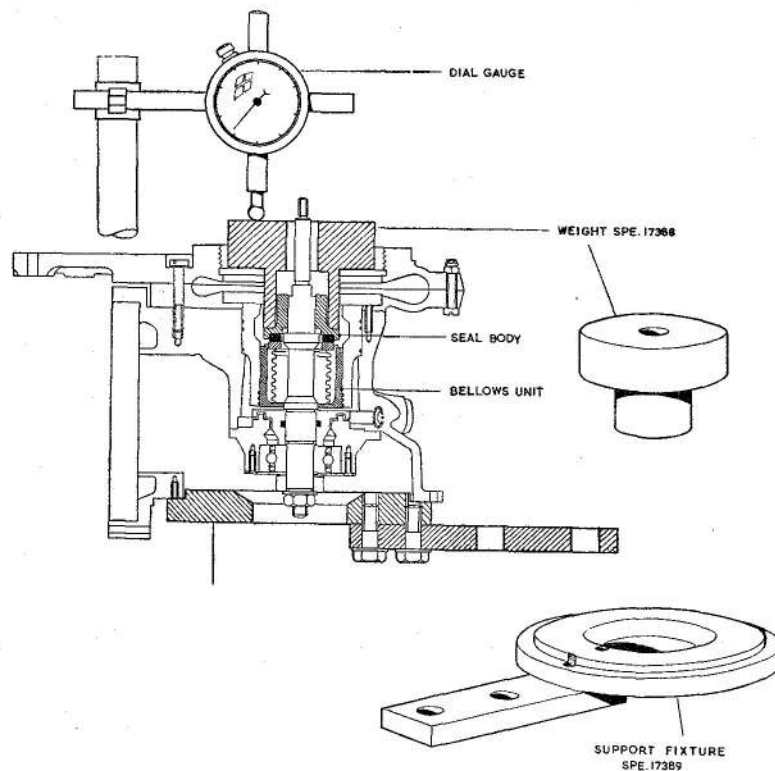

**Fig. 19. Bellows gland loading fixture**

(2) Lubricate the carbon bearing in lower bearing housing assembly (62) with kerosene. Secure through volute assembly to pump casting with five screws (72). Peen metal into slots to lock, ensuring that none projects above housing surface.

#### **34. Assembling centrifugal impeller and helix**

(1) Fit a number of shims (53) over shaft. Fit impeller gauge SPE.17372 (*fig. 9*) and using any suitable spacer fit a 2-B.A. nut to spindle and tighten to fully compress soft aluminium shims (73). Depress captive pin in impeller gauge until it contacts under surface of the lower bearing housing (62). Remove nut and spacer. Withdraw gauge and by comparison with the feeler gauge slips, determine the projection of the pin above the surface of the gauge. Progressively reduce thickness of shims (53) fitted until projection of the gauge pin is 0.005 in.

(2) Fit impeller (54), locating dowel (61) through shims into underside of bellows seal body (74). Fit any suitable spacer

giving clearance to impeller dowel over shaft and secure with 2-B.A. nut. Check by rotation that the impeller does not touch the undersurface of the lower bearing housing.

(3) Fit helix shroud (52), and using special spanner SPE.17374 (*fig. 9*) tighten until it just touches the impeller. Slacken the shroud approximately  $\frac{1}{4}$  turn so that the vertical slot in the thread is adjacent to one of the four studs in the volute assembly.

(4) Remove nut and spacer from shaft and fit helix (55) together with any shims (60) necessary to ensure that helix blades project 1.0 mm (0.039 in.) above rim of shroud (52). Secure helix to shaft with washer (57) and self-locking nut (58).

#### **35. Assembling filter**

(1) Position a pillar (49) on each of the four volute studs (63). Fit helix shroud locking tab (48) over one pillar so that the tab locates in the vertical groove in shroud thread. Fit spring (64) over each pillar and position vapour guide cone (65).

**RESTRICTED**

(2) Assemble filter (50) and hold in position against spring pressures and check that the bell mouth of vapour guide cone is between 0.75 and 1.0 mm below the tips of the helix blades (fig. 12). Thread locking wire through the holes in the volute casting and vapour guide cone, and bring it out through the mesh of the filter. Twist the ends together twice. Secure the filter assembly to the studs with self-locking nuts (51).

**36. Assembling by-pass valve and delivery connection.**

(1) Assemble flap valve (130) and hinge plate (127) by inserting flap valve hinge pin (129) which should be riveted over at both ends. Check that the valve hinges freely. Secure the hinge plate to housing (123) with two screws (126). Peen metal into slots to lock.

**Note . . .**

*Valve plate should be assembled with dished surface uppermost.*

(2) Position by-pass filter assembly (125) in valve housing (123) and retain with internal circlip (124).

(3) Paint the mating surfaces of the by-

pass valve housing and the outlet connector (121) with wellseal jointing compound, position new-gasket (128) and secure the two parts with six screws (122). Peen metal into slots to lock.

(4) Paint the mating surfaces of volute assembly (66) and outlet connector (121) with Wellseal jointing compound. Fit new gasket (132) and securely bolt the two castings together with the four bolts (133) and self-locking nuts (131). Tighten nuts on the outlet connector.

(5) Protect connector outlet with plug or masking tape to prevent foreign matter entering the pump unit.

(6) Fit drain plug (78) and washer (77) to pump casting.

**Motor unit to pump unit**

**37. Bevel pinion shimming (fig. 20).**

(1) Before completing the motor unit assembly, it is necessary to determine the thickness of shim (90) required to position the bevel pinion and obtain correct meshing with pump shaft gear. Proceed as follows:—

(a) Remove nut (35) and washer (36) securing the spacer or bevel gear to

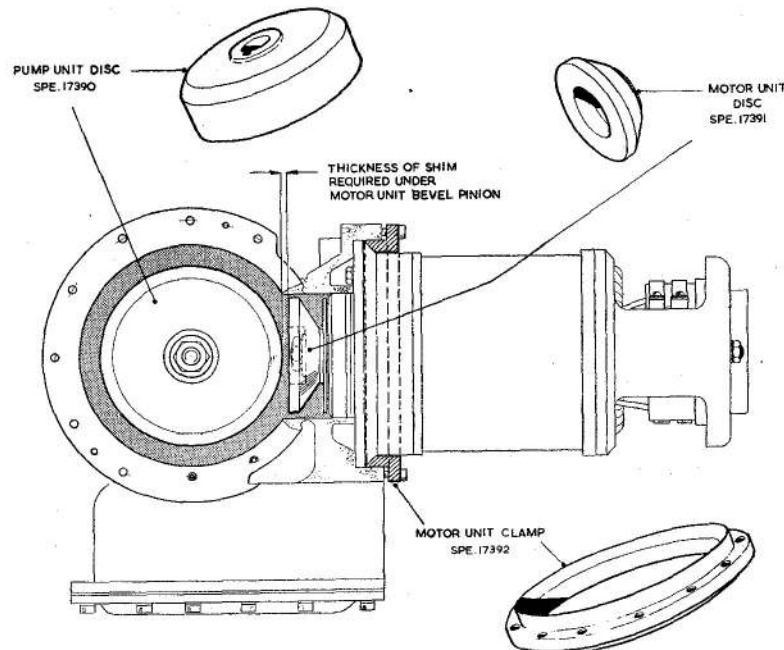

**Fig. 20. Determination of bevel pinion shimming**

~~RESTRICTED~~

pump shaft. If gear is fitted, use extractor SPE.17370 (*fig. 9*) to assist removal. Fit special disc SPE.17390 to pump shaft and secure.

(b) Remove the distance piece or bevel pinion fitted to the motor unit. Fit special disc SPE.17391 to motor spindle and secure.

(c) Locate the motor unit in the recessed housing of the pump casting and secure in position with special clamping ring SPE.17392. To facilitate location of the motor end casing on dowel in pump casting, mark the end casing before inserting. Use 6-B.A. bolts in four positions only to securely clamp the motor unit in position.

(d) With feeler gauges measure the gap between the outer edge of the pump shaft disc and the front face of the motor spindle disc (*fig. 20*). This is the thickness of the shim required for correct assembly of the pinion on the motor spindle.

(e) Separate the motor from the pump unit by removing the clamp ring and remove disc. Select shims (90) of correct total thickness and check that they are free of edge burrs. With driving key (105) in position, press on bevel pinion (108). Note that this pinion should be marked so that it can be easily paired with matched bevel gear as supplied. Secure the pinion with clamp washer (107) and self-locking nut (106) and tighten. Fit new joint ring (92) in groove in end casing.

(f) Inspect the motor unit for cleanliness, tightness of all screws (c/sk. head screws should be locked by peening metal into their slots) and condition of brush leads. The spindle thread should protrude through the nut securing the pinion. Check that the motor unit turns freely with no indication of sticking.

**Note . . .**

*Paragraph (g) and (h) assume that a paired gear assembly with known backlash characteristics is being fitted. Unpaired gears will not be engraved with meshing points. Bevel gear (108) should be painted on all except clamping surfaces with colloidal graphite and allow to dry before fitting.*

(g) Remove the pump shaft disc and fit excess shims (81), bevel gear key (82) and bevel gear (108). Place special

starwheel SPE.17396 (*fig. 21*) on top of the gear and align it so that one arm is between markings X-X which will be found engraved on two adjacent gear teeth. Secure the starwheel with a  $\frac{1}{4}$  in. B.S.F. nut.

(h) Lubricate the motor unit seal with a smear of Silicone MS 4 compound A.339 Ref. No. 33C/9424829. Ease the complete motor assembly into the pump unit casting, threading the motor leads through the channel leading to the suppressor chamber. If a paired gear and pinion are being fitted, align them so that the pinion tooth marked X is meshed between the two gear teeth similarly engraved X. This alignment is important. Locate the motor unit by registering the pump casing dowel pin in the motor end casing hole. Hold in position.

**38. Gear alignment (*fig. 21*).**

(1) Fit casing SPE.17393 over the motor unit and secure it to the pump casting in four positions. Clamp the motor spindle end nut in the indexing rod SPE.17394. If unpaired gears are being fitted, set the gears so that one arm of the starwheel is in line with the motor centre-line and secure the indexing rod. Mark the meshing gear and pinion teeth so that the starting point for backlash check can be determined.

(2) Take up the backlash between the gears and note whether the reading on an angular contact dial gauge graduated in 0.0005 in. indicates that it is (a) within limits 0.002 in./0.006 in. or (b) in accordance with first backlash figure quoted on the label supplied with the paired gears under check. The ball of the clock gauge should be located on the flat portion of the star point at a position close to its end. If the reading is outside the limits, remove the starwheel, withdraw the bevel gear using extractor tool SPE.17370 (*fig. 9*) and reduce the thickness of shim (81) fitted. Re-assemble and align gear and starwheel. Recheck backlash. Continue to reduce the shim thickness until the reading on the dial gauge indicates that the backlash at the starting point is (a) within specified limits, or (b), when figures are available, in accordance with first figure on the label for the pair of gears being assembled.

(3) Rotate the starwheel through 90 degrees ( $\frac{1}{4}$  revolution) in a clockwise direction and re-check. The backlash

~~RESTRICTED~~

must be within 0.002 in. of the reading at the initial check point, and within the range 0.002 in./0.006 in. Adjust shims (81) if outside this limit and range and re-check at the initial and second positions. Repeat the check twice after further  $\frac{1}{4}$  revolutions of the gear wheel. Mark the meshing after the final check.

(4) Remove the pump shaft nut and washer, and withdraw the gear wheel using the extractor. Rotate the gear through

$\frac{1}{8}$  revolution in a clockwise direction and replace the gear wheel in mesh with the pinion. Check and record backlash. Rotate the gear wheel a further  $\frac{1}{8}$  revolution in a clockwise direction, check and record backlash. Repeat the operation a further seven times checking after each movement of gear. The backlash figures at all positions of check must be within 0.002 in. of one another and within the range 0.002 in./0.006 in. Any adjust-

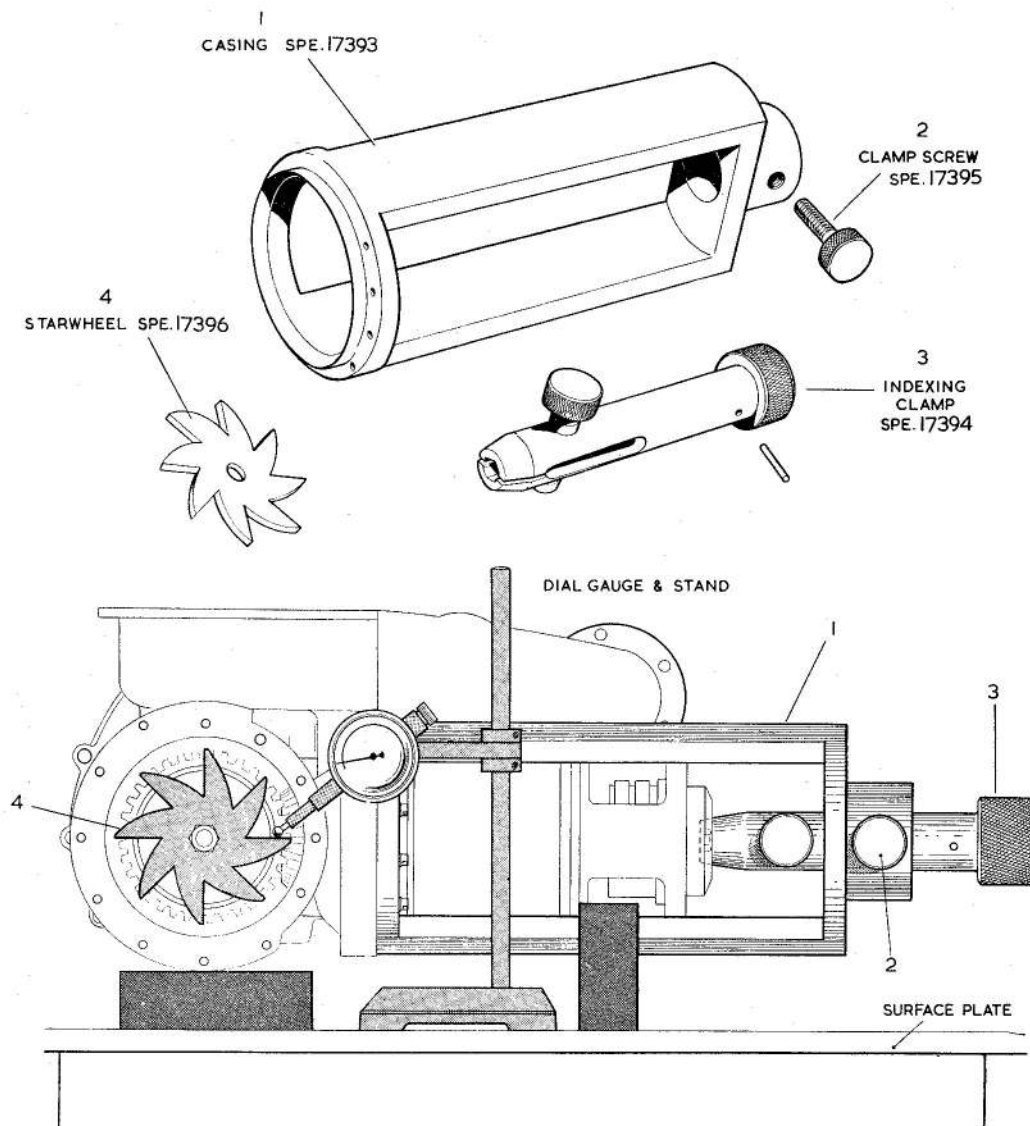

BACKLASH CHECKING (DIAGRAMMATIC)

Fig. 21. Backlash checking tools

~~RESTRICTED~~

ment of shimming necessitates a re-check of the backlash figures at all previously completed check points.

(5) Remove the starwheel from the pump gear shaft, refit clamp washers (83) and self-locking nut (84). Hold the gear wheel with special key SPE.17371 (fig. 9) and securely tighten the nut with a box spanner. Remove the pump from its fixture.

#### 39. *Assembling the outer motor casing.*

(1) Position a new sealing ring (102) over motor outer casing (91). Fit the casing over the motor unit and secure the casing with bolt ring (101) using seven screws (88) with self-locking nuts (87) and five screws (93) with shakeproof washers (89). Tighten the nuts or screws in turn to equally compress joint ring.

#### 40. *Gear box assembly.*

(1) Fill up measure (SPE.17379) with Gredag graphited grease Atcheson Grade ZV. Press the full amount into the gear box ensuring that some is forced into the teeth of the gear and pinion.

(2) Degrease the pump casting flange taking care not to let the solvent get into the grease. Paint the flange surface with jointing compound and also the mating surface of the gear box cover gasket (integral with cover). Secure cover with screws (111)-7 off: (85)-5 off spring washers (110) and self-locking nuts (109)-7 off. Tighten the locking nuts evenly in turn.

#### 41. *Electrical connection assembly.*

##### **Note . . .**

*If shunt leads (A) have not been connected during the stator assembly they should be twisted together, soldered, covered with a length of rubber sleeve which should be bent back over ends of joint and covered with a further sleeve.*

(1) To assemble contact pack, position a contact plate (141) on each side of central insulation plate (138), and an insulation strip (139) against each contact plate. Insert this pack into insulation body (144) and pin with two locking pins (140). Insert body assembly into flanged housing (143). Drill through the spigot of the housing 2 mm from the edge with drill No. 50 (0.070 in. dia.)  $\times$  5.0 mm deep and tap 8 B.A.  $\times$  4.0 mm deep. Lock

the body assembly by screwing grub-screw (142) into this hole.

(2) Solder lead ((165)-upper: (166)-lower) to each contact plate.

(3) Smear the flanged face of the housing and the mating surface of the pump casting with Wellseal jointing compound. Position a new gasket (118) and secure the electrical connection assembly to the casting with six cheese-head screws (120) and shakeproof washers (119).

#### 42. *Capacitor units assembly.*

(1) Secure capacitor units (160) to carrier assembly (161) with two screws (158) and shakeproof washers (159) per unit.

(2) Connect one stator lead and one supply lead (165 : 166) to each capacitor unit terminal. Leads numbered 1 to be taken to the upper unit, those numbered 2 to the lower. Assemble the leads adjacent to one another and retain them with plain washer (162), shakeproof washer (163) and nut (164). The stator leads are to be brought round the back of the panel and through the slots provided at the left-hand edge.

(3) Retain the capacitor panel assembly with self-locking nuts (117) and plain washers (116) on the two studs, with screw (135) and spring washer (134) in upper left-hand position. Ensure that all soldered connections are sound.

(4) Check the insulation resistance between each terminal and frame using a 250 volt constant pressure insulation resistance tester. The reading measured should be not less than 50 megohms.

(5) Smear the mating surfaces of the capacitor housing and cover (112) with Wellseal jointing compound. Secure the cover with 6-B.A. screws (113) spring washers (114) and self-locking nuts (137) in fourteen positions and with 4-B.A. screws (155) and spring washers (156) in two positions.

#### 43. *Locating plug assembly.*

(1) To ensure a good seal between the locating plug (96) and extension of lower volute casting, lap the top surface of the former.

(2) Check that drain tube (100) is positioned in the locating plug. Fit breather plug assembly (99).

(3) Paint the mating surfaces of the locating plug and volute casting with jointing compound. Position a new gasket (95)

**~~RESTRICTED~~**

and secure the plug to the volute with three bolts (97) and self-locking nuts (94) also two screws (104) and shakeproof washers (103).

(4) Fit new seal rings (98) in external grooves of locating plug.

#### 44. Pressure test pump assembly.

(1) Smear locating plug seal rings (98) with Silicone MS 4 compound A.339, Ref. No. 33C/9424829. Fit pressure test fixture SPE.17397 (fig. 22) over plug. Retain this fixture by securing the long screw across the back of the volute casting.

(2) Gradually increase the applied air pressure through the fixture from zero to 10 lb./in<sup>2</sup>. and maintain the pressure for five minutes. Air bubbles at any point will indicate a leakage past the seals or gland. None is permitted. If leakage is evident, the faulty seal must be dismantled and replaced after drying the affected surfaces. Re-assemble and re-check.

(3) The pump is now ready for testing in accordance with the Schedule of Test (para. 50-55). After satisfactory completion of the tests the assembly is to be wire-locked at the following places:—

(a) Gear box cover to capacitor housing cover.

(b) Gear box cover to motor casing bolt ring.

(c) Pump casing to capacitor cover.

(d) At filter (attach seal to wire fitted during pump unit assembly (para. 35)).

Overhaul organisations should use their own seals for this purpose. The gland drain plug should be wire-locked after tightening, using 22 s.w.g. locking wire.

#### Electrical connection (female)

#### Note . . .

This is attached to the electrical supply lead in tank.

45. (1) Position a contact plate (148) on either side of central insulation plate (149). Fit outer insulation plates (147) and insert sub-assembly into locking bush (151). Positively locate with locking pins (146). Position (2) union nut (154) over body (153) and fit contact insulation bush (152) internally. Pull the leads through the body, and solder them to the contact plates.

(3) Position the locking bush in the body, fit insulation bush (167) and retain with circlip (150).

#### TESTING

#### General

46. The complete pump must be tested in accordance with the Schedule of Tests detailed as follows (para. 49-55). The pump should be rejected if it fails to comply with the Schedule of Tests.

#### Test equipment

47. A diagrammatic arrangement of a suitable test rig for SPE.800 series fuel pumps as illustrated in Fig. 23. Alternatively use a universal fuel pump test rig if available. Use AVTUR fuel for tests.

#### Preparation

48. Check that seal rings have been fitted in the two external grooves of the locating plug. Bolt the pump to the mounting plate and secure to stud ring of test tank.

#### SCHEDULE OF TESTS

#### Brush bedding and motor torque test (motor unit only)

49. Full details on the procedure to be adopted are given at the appropriate stage

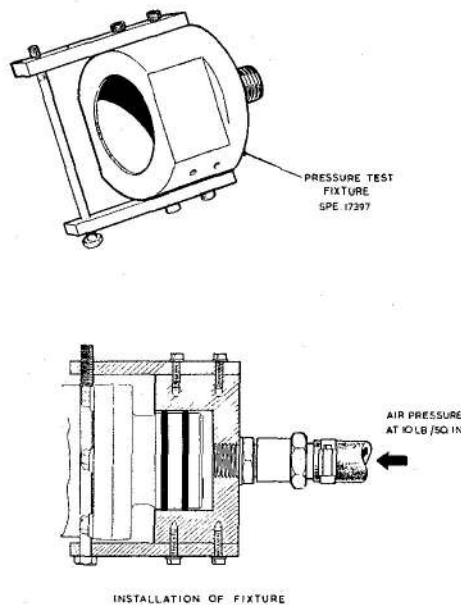

Fig. 22. Pressure test fixture

~~RESTRICTED~~



in the assembly sequence. Conditions to be fulfilled are as follows:—

(1) The brushes must bed over their full width of arc with at least 80 per cent. of their face area in contact with commutator.

(2) The motor is to be subjected to a torque of 24 oz. in. applied by means of the calibrated fan SPE.17399 or by a suitable dynamometer. At 24 volts d.c. input the motor speed should be  $9800 \pm 100$  r.p.m. with the brush gear retarded  $10.5 \pm 4.5$  degrees from the geometric neutral axis and the motor unit at normal running temperature. The maximum current consumption is 11.5 amps.

#### Insulation resistance test

50. The insulation resistance is to be measured at the following times:—

(1) The motor unit only after brush bedding and motor torque test.

(2) The complete pump before pressure test (*para.* 51) and after the completion of the calibration test (*para.* 55).

All the above tests are to be carried out with the motor warm. Use a 250 volt constant pressure insulation resistance tester when suppressors are fitted and a 500 volts megger when they are not fitted. The resistance must at no time be less than 2 megohms (10 megohms after sub-para. (1).)

#### Pressure test

51. (1) With the pump fully submerged in fuel, apply air internally through the gland drain and motor breather at a pressure of 10 lb/in<sup>2</sup>. Maintain the air pressure for 5 minutes (*para.* 44). Observe for leakage of air bubbles into the fuel. A leakage attributable to the gland is permissible providing the pump complies

with the following sub-para. 2(c) and sub-para. 3. No other leakage is permissible.

(2) With the flow regulating valve closed and the pump fully submerged in fuel, run the pump fully on an input voltage of 28.8 volts d.c. for 15 minutes. Observe for:—

(a) External leakage of fuel.

(b) Internal leakage of fuel.

(c) Gland leakage. Allowable leakage is two drops per minute with pump running and one drop per minute when stationary.

(3) With the pump stationary and a 12 in. head of fuel over the mounting flange, apply air pressure at 10 lb/in<sup>2</sup>. for 15 minutes. Observe for fuel leakage as in (2) above. Allowable rate of leakage under these conditions is two drops per minute.

#### Starting test

52. With the pump fully submerged in fuel, and the supply voltage to the pump adjusted to 16 volts d.c., operate the pump by switching on the supply; the pump should start satisfactorily. Check the starting of the pump by operating the switch ten times.

#### Dry test

53. Mount the pump clear of fuel and run it dry for five minutes on an applied voltage of 28.8 volts d.c. The current observed during this test must at no time be greater than 6.0 amps.

#### Proof test

54. With a 6 in. head of fuel over the pump inlet, run the pump for one hour at each of (1) and (3) as listed in Table 4 and check for conformity at all conditions.

Table 4  
Proof test

	Volts d.c.	G.P.H.	Delivery Pressure Lb/in. <sup>2</sup>	Current— Amps (max)
1	22.0	800	8.5 (min)	11.0
2	24.0	800	10.5 (min)	11.5
3	28.8	800	13.5 (min)	13.0
4	28.8	0	20.5 (max)	12.0

~~RESTRICTED~~

The performance is to be recorded at the beginning and end of each hour's run. Reject the pump if any appreciable change in performance is observed other than that caused by the initial warming up.

**Calibration test**

55. With a 6 in. head of fuel above the pump inlet, adjust the flow regulating valve to obtain flows of 1,200, 1,000, 800, 600, 400, 200 and zero gallons per hour. Record the delivery pressure and motor current at each flow stage with the following voltages applied—22·0 volts d.c., 24·0 volts d.c., and 28·8 volts d.c.

**Dismantling for inspection**

56. This is to be reduced to an absolute minimum in the case of a pump which has satisfactorily completed the preceding tests. Normally no attempt should be made to break the joints already thoroughly tested. Should the authorised inspector, however, feel that a major strip for examination is necessary, the pump on re-build must be subjected to a repeat of all the preceding tests.

The acceptance performance of the pump is as follows:—

**Table 5**  
**Acceptance performance**

	Volts d.c.	Flow G.P.H.	Delivery pressure Lb/in. <sup>2</sup> (min)	Current Amps (max)
1	22·0	800	8·5	11·0
2	24·0	800	10·5	11·5
3	28·8	800	13·5	13·0

~~RESTRICTED~~

**Table 6**  
**Faults, possible causes and remedies**

Fault	Possible cause	Rectification
Gland leakage ....	(a) Bad finish between seal faces.  (b) Cracked carbon. (c) Insufficient pressure between gland seal faces.	Disassemble pump unit. Re-lap bellows unit seal face. If excessively worn, renew bellows unit and bellows seal housing. Renew bellows seal housing. Increase gland loading by fitting thinner shims (73) care being taken to maintain clearance between impeller and carbon bearing housing, within specified limits (Table 3).
Excessive current consumption.	(a) Faulty motor unit.  (b) Excessive loading on metallic bellows gland.  (c) Fouling of impeller by foreign matter. (d) Faulty bearings (indicated by pump being stiff to turn or an intermittent jerky resistance is felt when pump is rotated).	Check condition of brushes and commutator (Tables 2 and 3). Decrease gland loading by fitting thicker shims (73) care being taken to maintain clearance between impeller and carbon bearing housing within specified limits (Table 3). Remove inlet filter and examine. Clean as necessary. Check that pump and motor ball bearings are free turning. Disassemble pump as necessary and renew.
Excessive current but armature free to turn and pump will not start.	(a) Faulty coils.	Check field coils for continuity.
Very high current	Short circuit.	Check insulation resistance between one pole and motor frame. Check leads for chafing, etc.
Low or fluctuating current.	(a) Dirty commutator and brushes.  (b) Grease leakage from commutator and bearing making brushes 'stick'.	Disassemble and clean. Re-bed brushes on re-assembly. Renew faulty bearing. Clean brushes and commutator.
Low delivery pressure.	(a) Faulty motor.  (b) Impeller impedance.	Check motor speed and brush gear setting. Adjust if necessary. Check for obstruction. Check clearance.
Pressure surge ....	(a) Tight or pre-loaded bearings.  (b) Excessive loading on bellows gland.	Check fits: ease or replace as necessary. See 'Excessive Current Consumption'.
Low insulation resistance.	Dampness in motor windings.	Prolonged drying of armature and field at 93° C.

~~RESTRICTED~~

1

2

3

4

-----

## Appendix 1

## RECONDITIONING SPE.802 Mk. 2 FUEL PUMP

## LIST OF CONTENTS

	Para.		Para.
General	1	Insulation resistance test	8
<b>Reconditioning</b>		Pressure test	9
Tools and test equipment	2	Starting test	10
Dismantling	3	Dry test	11
Assembling	4	Proof test	12
<b>Testing</b>		Calibration test	14
General	5	Dismantling for inspection	16
Schedule of tests	6	Schedule of fits, clearances and repair tolerances	17
Preliminary motor run and torque test	7		

## LIST OF TABLES

	Table		Table
Proof test	1	Acceptance performance	2

## LIST OF ILLUSTRATIONS

	Fig.		Fig.
Radio interference suppression assembly	1	Upper pump bearing housing assembly	2

**General**

1. This appendix details differences in the dismantling and re-assembly procedure for SPE.802 Mk. 2 pumps as compared with those given for SPE.802B Mk. 3 in para. 4-44 of the main chapter. Full details of differences between the SPE.802 series pumps are given in A.P.4343D, Vol. 1, Book 2, Sect. 7.

**Note . . .**

*It is strongly recommended that whenever possible an SPE.802 Mk. 2 fuel pump is brought up to the latest production standard when overhauled.*

**RECONDITIONING****Tools and test equipment**

2. Refer to A.P.4343D, Vol. 6, Sect. 7, Chap. 18, para. 3.

**DISMANTLING**

3. Where no details are given under stage headings in the following breakdown, refer to the equivalent paragraph in A.P.4343D, Vol. 6, Sect. 7, Chap. 18.

(1) Removing the capacitors (*fig. 1*).

(a) Remove 14 screws ((113) washers (114) and nuts (137) as well as two screws (155) and washers (156). Withdraw capacitor cover backing plate (178), cover (177) and gasket (176).

(b) Remove locknuts (117) and washers (116) to free the capacitor panel assembly. Withdraw this panel as far as the field and electrical connecting leads will allow.

(c) Disconnect the field and plug connections from the capacitor units (173) by removing nuts (164), shakeproof washers (163 and plain washers (162).

**RESTRICTED**

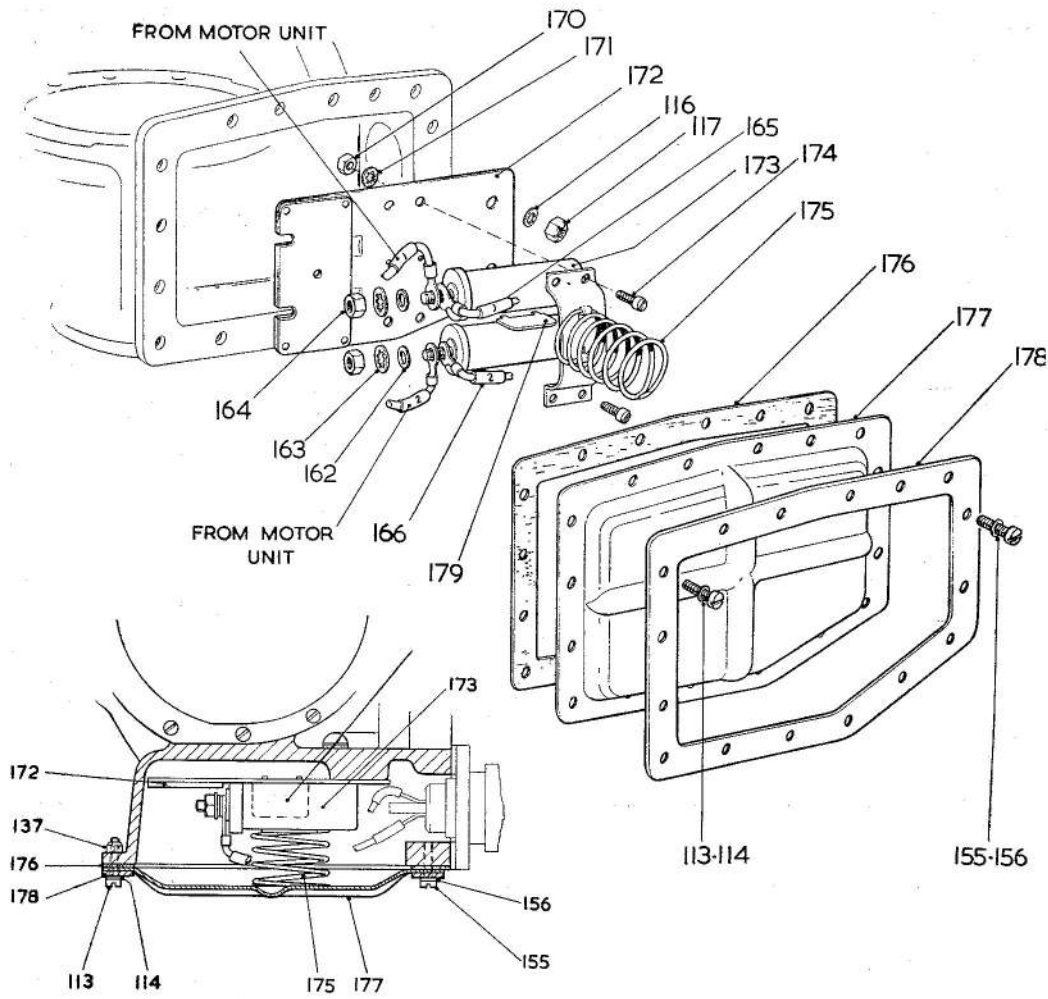

- |   |   |
|---|---|
| <b>113</b> CH. HD. SCREW (CAPACITOR COVER FIXING) | <b>165</b> ELECTRICAL CONNECTION LEAD (UPPER)       |
| <b>114</b> SPRING WASHER (CAPACITOR COVER FIXING) | <b>166</b> ELECTRICAL CONNECTION LEAD (LOWER)       |
| <b>116</b> PLAIN WASHER                           | <b>170</b> LOCKNUT                                  |
| <b>117</b> SELF-LOCKING NUT (PANEL FIXING)        | <b>171</b> SHAKEPROOF WASHER, ASSEMBLY FIXING CLAMP |
| <b>137</b> NUT (CAPACITOR COVER FIXING)           | <b>172</b> CAPACITOR MOUNTING PLATE ASSEMBLY        |
| <b>155</b> CH. HD. SCREW (CAPACITOR COVER FIXING) | <b>173</b> CAPACITOR                                |
| <b>156</b> SPRING WASHER (CAPACITOR COVER FIXING) | <b>174</b> CH. HD. SCREW (CLAMP FIXING)             |
| <b>162</b> PLAIN WASHER,                          | <b>175</b> CLAMP ASSEMBLY                           |
| <b>163</b> SHAKEPROOF WASHER,                     | <b>176</b> COVER GASKET                             |
| <b>164</b> LOCKNUT,                               | <b>177</b> COVER                                    |
|   | <b>178</b> COVER BACKING PLATE                      |
|   | <b>179</b> DIVIDING PLATE                           |

**Fig.1. Radio interference suppression assembly**

~~RESTRICTED~~

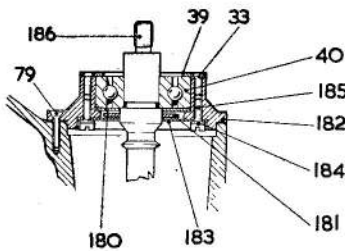
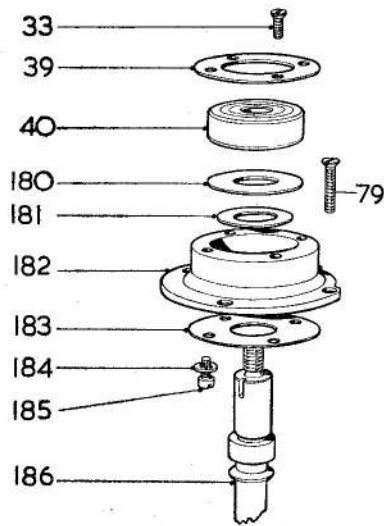

- 33 C/SK. HD. SCREW (BEARING RET. PLATE FIXING)  
 39 BEARING RETAINER PLATE  
 40 BALL BEARING  
 79 C/SK. HD. SCREW (BEARING HOUSING FIXING)  
 180 BEARING SHIELD  
 181 FLOATING WASHER  
 182 BEARING HOUSING  
 183 SEAL WASHER  
 184 SHAKEPROOF WASHER } SEAL WASHER  
 185 CH/HD. SCREW } ATTACHING  
 186 PUMP SHAFT

**Fig. 2. Upper pump bearing housing assembly**

The capacitors (173) can be released from clamp assembly (175) by removing four nuts (170), shakeproof washers (171) and screws (174). Retain the

dividing plate (179). Do not remove the spring from the clamp.

- (2) Separating the motor unit from the pump unit.  
Generally as for SPE.802B Mk. 3, the integral gear box cover and gasket may be replaced by a cover, a cover backing plate, and a separate gasket.
- (3) Removing the electrical connection.
- (4) Detaching and dismantling the outlet assembly.
- (5) Removing the locating plug and inlet filter.
- (6) Removing the helical and centrifugal impellers.
- (7) Withdrawing the volute assembly.
- (8) Removing the bevel gear and upper bearing assembly. (fig. 2).

(a) Holding the gear with special key SPE.17371 (fig. 9) unscrew and remove self-locking nut (84) and washer (83) securing bevel gear (108) to shaft (186). Using extractor tools SPE.17370 (fig. 9) withdraw the gear. Remove any shims (81) fitted and retain the driving key (82).

**Note . . .**

*If it is intended to re-use the gear, it must be paired with the pinion of the motor unit originally fitted to the pump unit. Re-use of the gear is not recommended.*

(b) Remove four screws (79) securing the upper ball race housing to the pump casting. Break joint gasket (76) and withdraw the housing sub-assembly with the pump shaft in position. Take care not to damage the bellows unit when withdrawing the shaft through it.

(c) Withdraw the shaft from the bore of the bearing. Remove the four screws (33) and withdraw the bearing retainer plate (39). Remove the four screws (185) and shakeproof washers (184) to release the seal washer (183), floating washer (181) and bearing shield (180). Press out the bearing (40).

- (9) Removing the bellows housing assembly.

**Note . . .**

*No drain plug is fitted to the pump casting.*

~~RESTRICTED~~

- (10) Disconnecting the field leads and removing the brushes.
- (11) Removing and dismantling commutator-end motor casing.
- (12) Dismantling drive-end motor casing.

#### ASSEMBLING

4. Where no details are given under stage headings in the following breakdown refer to the equivalent paragraph in A.P.4343D, Vol. 6, Sect. 7, Chap. 18.

- (1) Assembling the drive-end motor casing.
- (2) Assembling the upper bearing and sleeve.
- (3) Assembling the brush box.
- (4) Assembling the armature to drive-end motor casing assembly.
- (5) Fitting the drive-end motor casing and armature assembly to stator and commutator-end motor casing assembly.
- (6) Pre-bedding of brushes.
- (7) Preliminary brush bedding motor run.
- (8) Motor speed setting.

The motor unit should now be torque tested and the speed set in accordance with figures detailed in the Schedule of Tests (*para.* 6). The method of setting by retardation from geometric neutral axis as described in *para.* 28 does not apply to the Mk. 2 motor unit.

- (9) Reaming the carbon bearing (pump unit).
- (10) Assembling the bellows unit sub-assembly.
- (11) Shaft component check (*fig.* 2).

(a) Pre-select a bearing (40) that is a slide fit under thumb pressure both on pump shaft (186) and in ball-race housing (182). Retain shaft and housing and suitably mark both so that they can be paired with a selected bearing and built into the same pump unit at a later assembly stage. Check that the selected bearing is smooth running with no roughness when the inner race is rotated by hand.

(b) Check that the bearing housing is perfectly clean and that the wall surface is smooth and free from score marks, burrs, adhering swarf etc. Fit bearing shield (180) dished side uppermost in housing and insert selected bearing. Retain with plate (39) and four screws (33). Peen metal into screw slots to lock. Position floating washer (181) in the underside of the housing. Retain

with seal washer (183), four screws (185) and shakeproof washers (184).

(c) Fit the bearing housing sub-assembly, the bellows seal body, the centrifugal impeller and helix to the selected shaft in the correct assembly positions. Inspect for fit of components on the shaft and ensure that all components will tighten flush against the shaft shoulders. Retain all components for assembly into the same pump unit.

- (12) Upper ball race housing assembly.
- (13) Determination of correct bellows loading.
- (14) Assembling the centrifugal impeller and helix.
- (15) Assembling the filter.
- (16) Assembling the by-pass valve and delivery connection.
- (17) Bevel pinion shimming.
- (18) Gear alignment.
- (19) Assembling the outer motor casing.
- (20) Gear box assembly.

(a) Fill up measure (SPE.17379—*fig.* 9) with Gredag Atcheson graphited grease Grade ZV. Press the full amount into the gear box, ensuring that some is forced into the teeth of the gear and pinion.

(b) Degrease the pump casting flange taking care not to allow the solvent to contact the grease. Paint the mating surfaces of the pump casting and cover with Wellseal jointing compound. Position a new gasket cover and backing plate. Secure the cover with screws ((111)—7 off: (85)—5 off), spring washers (110) and self-locking nuts (109)—7 off.) Tighten evenly in turn.

#### Note . . .

*A backing plate is only used with pressed covers. Die-cast covers do not require it.*

- (21) Electrical connection assembly.
- (22) Capacitor units assembly (*fig.* 1).
  - (a) Position capacitors (173) on mounting plate (172) and separate with dividing plate (179), the ears of which locate in the mounting plate slots. Clamp the capacitors to the plate with clamp assembly (175) using four screws (174), shakeproof washers (171) and locknuts (170).

~~RESTRICTED~~

(b) Connect one stator lead and one supply lead (165 : 166) to each capacitor unit terminal. Leads numbered 1 to be taken to upper unit, those numbered 2 to lower. Assemble leads adjacent to one another and retain with plain washer (162), shakeproof washer (163) and nut (164). The stator leads are to be brought round the back of panel and through the slots provided at the left-hand edge. Retain the capacitor panel assembly with self-locking nuts (117) and plain washers (116) on the two studs.

(c) Check the insulation resistance between each terminal and the frame using a 250 volt constant pressure insulation resistance tester. The reading measured should be not less than 50 megohms.

(d) Smear the mating surfaces of the capacitor housing and cover (177) with Wellseal jointing compound. Position a new gasket (176) fit the cover and backing plate (178) and secure with 6-B.A. screws (113), spring washers (114) and self-locking nuts (137) in fourteen positions, and with 4-B.A. screws (155) and spring washers (156) in two positions.

**Note . . .**

*The backing plate (178) is only used with pressed covers. Die-cast covers do not require it.*

(23) Assembling the locating plug.

(24) Pressure test pump assembly.

## TESTING

### General

5. The complete pump must be tested in accordance with the Schedule of Tests detailed below. The unit should be rejected if it fails to comply with this schedule. Where no details are given under test headings, refer to the equivalent paragraph of Schedule of Tests for SPE.802B Mk. 3 fuel pump (*A.P.4343D, Vol. 6, Sect. 7, Chap. 18, para. 49-55*).

Test equipment and preparation are as for SPE.802B Mk. 3 fuel pump.

### Schedule of tests

6. Use AVTUR Fuel throughout for these tests.

#### *Preliminary motor run and torque test.*

7. Run the motor unit off-load, at 28.8 volts d.c. for three hours or longer, until the brushes bed over 100 per cent. arc, with at least 80 per cent. of their face area in contact with commutator. The motor unit should be run without the gland to avoid undue wear. At the conclusion of this run the motor speed and current consumption at 24 volts d.c. is to be checked when the motor unit is subjected to a torque of 24 oz. in. applied by means of the calibrated fan SPE.17375 (*fig. 9*), or suitable dynamometer. Adjust the brush box position to obtain figures within the following limits. Speed  $9,800 \pm 100$  r.p.m. Current—12.0 amp. max.

#### *Insulation resistance test*

8. Refer to Chap. 18, para. 50.

#### *Pressure test*

9. Refer to Chap. 18, para. 51.

**Table 1**  
**Proof test**

Volts d.c.	Flow G.P.H.	Delivery pressure Lb/in. <sup>2</sup>	Current— Amps (max)
1 22.0	800	9.0 (min)	11.5
2 24.0	800	11.0 (min)	12.0
3 28.8	800	14.0 (min)	13.5
4 28.8	0	21.0 (max)	12.5

~~RESTRICTED~~

*Starting test*

10. Refer to Chap. 18, para. 52.

*Dry test*

11. Refer to Chap. 18, para. 53.

*Proof test*

12. With a 6 in. head of fuel over the pump inlet, run the pump for one hour at each of (1) and (3) of the conditions in Table 1 and check for conformity of voltage flow pressure and current.

13. The performance is to be recorded at the beginning and end of each hours run. Reject the pump if any appreciable change in performance is observed, other than that caused by the initial warming up.

*Calibration test*

14. With a 6 in. head of fuel above the pump inlet, adjust the flow regulator valve to obtain flows of 1,200, 1,000, 800, 600, 400, 200, and zero gallons per hour. Record delivery pressure and motor current at each flow stage with the following voltages applied—22·0 volts d.c. 24·0 volts d.c. and 28·8 volts d.c.

15. The acceptance performance of the pump is as shown in Table 2:

*Dismantling for inspection*

16. Refer to Chap. 18, para. 56.

**Schedule of Fits, Clearances and Repair Tolerances**

17. Refer to Chap. 18, Table 3.

**Table 2**  
**Acceptance performance**

	Volts d.c.	Flow G.P.H.	Delivery pressure Lb/in. <sup>2</sup> (min)	Current— Amp., (max)
1	22·0	800	9·0	11·5
2	24·0	800	11·0	12·0
3	28·8	800	14·0	13·5

~~RESTRICTED~~

**Appendix 2****RECONDITIONING SPE.802 Mk. 3 FUEL PUMP****General**

1. SPE.802 Mk. 3 fuel pump returned for overhaul should be brought up to 802B Mk. 3 standard by replacing existing brushes with brush assemblies fitted with Nimonic alloy springs. This part constitutes the only difference between the two types of pump (at issue date of this Appendix). Dismantling, repair, assembly and testing are therefore similar to that detailed for SPE.802B Mk. 3 fuel pumps in A.P.4343D, Vol. 6, Sect. 7, Chap. 18.

C

C

C

C

C

C

C

C

C

C

C

C

C

C

C

C

C

This file was downloaded  
from the RTFM Library.

Link: [www.scottbouch.com/rtfm](http://www.scottbouch.com/rtfm)

Please see site for usage terms,  
and more aircraft documents.

