

Do not destroy.

Chapter 24

PUMPS, FUEL, SPE.1302

LIST OF CONTENTS

	Para.		Para.
Introduction	1	Assembling the brush gear	23
Reconditioning		Assembling the top motor end casing	24
Tools and test equipment	3	Assembling the yoke, armature, and end casing sub-assemblies	25
Dismantling		Pre-bedding the brushes	26
General	4	Preliminary brush bedding motor run	27
Removing the capacitors	5	Motor speed setting	28
Removing the electrical connection ...	6	Pump unit	
Removing the base filter assembly ...	7	Sub-assembling the pump body casting	36
Removing the motor outer casing assembly	8	Sub-assembling the electrical con- nection	37
Removing the helical and centrifugal impellers	9	Assembling the motor unit to the pump body casting	38
Removing the lower bearing housing ...	10	Assembling the lower bearing ...	39
Separating the motor unit from the pump body casting	11	Fitting the outer motor casing ...	40
Completing the dismantling of the pump body casting sub-assembly ...	12	Pre-assembling the centrifugal im- peller	41
Dismantling the motor unit		Assembling the seal	43
Disconnecting the field leads and re- moving the brushes	13	Assembling the capacitor	44
Removing the top motor end casing assembly	14	Pressure testing the seal assembly ...	45
Dismantling the top motor end casing	15	Assembling the helix shroud	46
Dismantling the brush box assembly	16	Assembling the impeller helix	47
Dismantling the lower motor end casing assembly	17	Assembling the vapour guide cone and inlet filters	48
Cleaning, examination and repair		Testing and wire locking	49
Cleaning	18	Testing	
Examination		General	50
General	19	Test equipment	51
Detailed procedure	20	Preparation	52
Assembling		Schedule of tests	
General	21	Starting test	53
Motor unit		Gland leakage test	54
Assembling the lower motor end casing	22	Proof and calibration tests	55
		Dry test	56
		Dismantling for inspection	57

RESTRICTED

LIST OF TABLES

	<i>Table</i>
<i>Special tools and equipment ...</i>	1
<i>Detailed examination of components ...</i>	2
<i>Schedule of fits, clearances and repair tolerances ...</i>	3
<i>Acceptance limits: Proof and calibration tests ...</i>	4

LIST OF ILLUSTRATIONS

	<i>Fig.</i>			<i>Fig.</i>
<i>Sectional view of pump unit ...</i>	1		<i>Typical motor unit clamp ...</i>	7
<i>Sectional view of suppressor housing and electrical connection ...</i>	2		<i>Brush gear setting, Circuit Diagram 1</i>	8
<i>Exploded view of pump unit ...</i>	3		<i>Brush gear setting, Circuit Diagram 2</i>	9
<i>Exploded view of motor unit ...</i>	4		<i>Electrical connection sealing: instruction diagram ...</i>	10
<i>General tools ...</i>	5		<i>Pressure test tools ...</i>	11
<i>Fits and clearances diagram ...</i>	6		<i>Test rig ...</i>	12

LIST OF APPENDICES

	<i>App.</i>
<i>Reconditioning SPE.1302 Mk. 1 and SPE.1302 Mk. 2 Fuel Pumps ...</i>	1

Introduction

1. A general description of the SPE.1302 fuel booster pump is given in A.P.4343D, Vol. 1, Book 2, Sect. 7, Chap. 24, and details of the variations between the different mark numbers are given in an appendix to the chapter. Reconditioning instructions are given in this chapter for SPE.1302, Mk. 3 pumps and appendices will be issued to cover differences for the earlier, or later versions of the pump.

2. The pump assembly comprises a 24V d.c. motor unit driving an impeller assembly which is carried on the extended armature spindle, and the complete pump unit is assembled to a mounting plate which is

part of the aircraft structure. Pumps returned for reconditioning may be found to be fitted with a delivery outlet connection attached to the pump outlet casting. This outlet connection incorporates a by-pass valve, and is not part of the basic pump assembly; information on the outlet connection and mounting plate will be given in the aircraft handbook.

RECONDITIONING

Tools and test equipment

3. In addition to the standard bench tools, the special tools listed in Table 1 are required to overhaul the SPE.1302 pump. Details of a suitable test rig are included in para. 51.

~~RESTRICTED~~

TABLE 1
Special tools and equipment

Nomenclature	Part Number	Fig.
Impeller extractor	SPE.19538	5
Extended cap screw key (4-B.A.)	SPE.20682	5
Extended cap screw key (2-B.A.)	SPE.20683	5
Thrower nut spanner	SPE.16199	5
Locking strip	SPE.20684	5
Pencil brush	SPE.16200	5
Electrical connection pin locating spigot	SPE.20680	5
Centralising gauge	SPE.19539	5
Calibration fan	SPE.16051	5
Armature spindle extension shaft	SPE.19542	5
Pressure test plug	SPE.17625	11
Joint ring	SPE.20685	11
Pressure test cover	SPE.17628	11
Joint ring	SPE.20681	11
Pressure test connector	SPE.17629	11
Gasket	SPE.12283	11
Distance piece (helix replacement)	SPE.19536	11
Pressure test fixture assembly	SPE.17397	11
Electrical connection pressure test fixture	SPE.20679	11
Pressure tapping connection	SPE.20962	12

DISMANTLING

General

4. Refer to fig. 1 and 2 (sectional views) and fig. 3 and 4 (exploded views), and cut the locking wires to all external seals (48, fig. 1).

Removing the capacitors (fig. 2)

5. (1) Remove the thirteen self-locking nuts (97), plain washers (98) and bolts (99) together with the three bolts (81) and spring washers (82). Withdraw the capacitor cover assembly (105).

(2) Remove the three cheesehead screws (92) and spring washers (93) securing the capacitor mounting bracket (96) to the pump body sub-assembly. Withdraw the capacitor bracket assembly as far as the field and electrical connection leads will allow.

(3) Disconnect the field and plug connections from the capacitor units (100) by removing the terminal lock-nuts (103), shakeproof washers (102) and plain washers (101). The capacitors (100) can be detached from the bracket (96) by removing the two

RESTRICTED

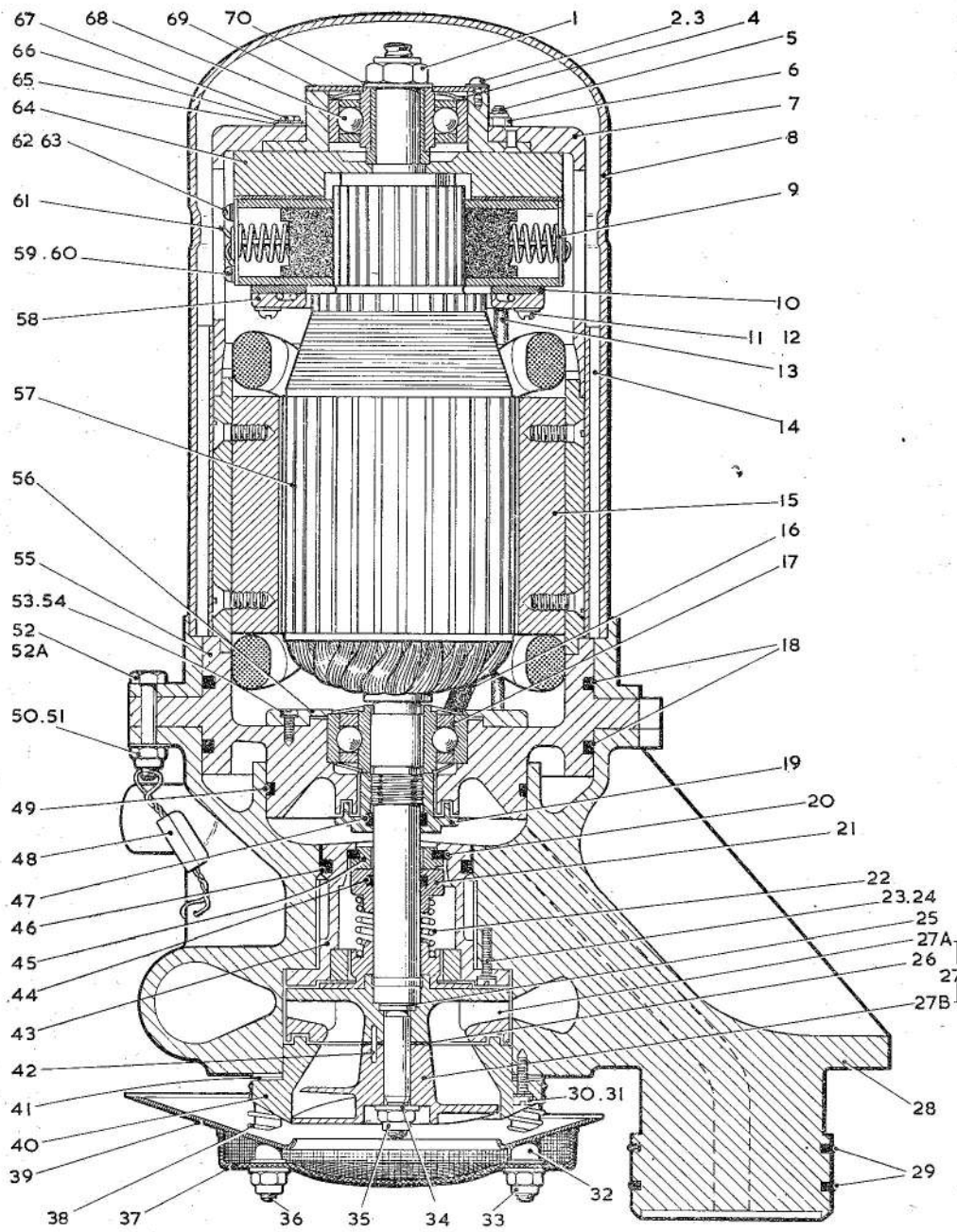

Fig. 1. Sectional view of pump unit

RESTRICTED

Key to Fig. 1

1	SPINDLE END NUT, UPPER	
2	ROUND HEAD SCREW	RETAINING
3	SHAKEPROOF WASHER	PLATE FIXING
4	BEARING PRE-LOAD WASHER	
5	MOTOR TIE BOLT	
6	SELF-LOCKING NUT (TIE BOLT)	
7	TOP MOTOR END CASING	
8	MOTOR OUTER CASING ASSEMBLY	
9	BRUSH ASSEMBLY	
10	TERMINAL LEAD RETAINING PLATE	
11	ROUND HEAD SCREW	LEAD HOUSING
12	SHAKEPROOF WASHER	RETAINING
13	TIE BOLT INSULATION SLEEVING	
14	COOLING SLEEVE	
15	YOKE ASSEMBLY	
16	RUBBER SLEEVE	
17	BALL BEARING, LOWER	
18	SEAL RING, MOTOR	
19	THROWER NUT	
20	STATIONARY SEAL RING PACKING	
21	ROTARY SEAL RING	
22	SPRING	
23	CHEESE HEAD SCREW	SEAL HOUSING FIXING
24	SHAKEPROOF WASHER	
25	IMPELLER ADJUSTING SHIMS	
26	HELIX ADJUSTING SHIM	
27	IMPELLER/HELIX ASSEMBLY	
27A	IMPELLER (AND LOWER BEARING)	
27B	HELIX	
28	PUMP BODY CASTING	
29	SEAL RING, LOCATING PLUG	
30	CHEESE HEAD SCREW	HELIX SHROUD
31	SPRING WASHER	FIXING
32	FILTER PILLAR	
33	SELF-LOCKING NUT	
34	PLAIN WASHER	
35	SPINDLE END NUT, LOWER	
36	STUD, FILTER FIXING	
37	BASE FILTER ASSEMBLY	
38	FILTER SPRING	
39	VAPOUR GUIDE CONE	
40	HELIX SHROUD	
41	HELIX SHROUD ADJUSTING SHIMS	
42	SPRING DOWEL	
43	SEAL (LOWER BEARING) HOUSING	
44	ROTARY SEAL RING PACKING	
45	STATIONARY SEAL RING	
46	SEAL RING, SEAL HOUSING	
47	SEAL RING, THROWER NUT	
48	LOCKING SEAL WIRE	
49	SEAL RING, MOTOR TO PUMP UNIT	
50	SELF-LOCKING NUTS	MOTOR OUTER CASING
51	PLAIN WASHER	AND MOTOR FIXING
52	HEX. HEAD BOLT	MOTOR OUTER
52A	HEX. HEAD BOLT, SPECIAL	CASING FIXING
53	CHEESE HEAD SCREW	LOWER BEARING
		RETAINING PLATE
54	SHAKEPROOF WASHER	FIXING
55	MOTOR END CASING, LOWER	
56	LOWER BEARING RETAINING PLATE	
57	ARMATURE ASSEMBLY	
58	TERMINAL LEAD HOUSING	
59	ROUND HEAD SCREW	BRUSH PIGTAIL AND
		PAIRING LEAD
60	SPRING WASHER	FIXING
61	BRUSH PAIRING LEAD	
62	ROUND HEAD SCREW	BRUSH RETAINING
		PLATE AND FIELD
		LEAD TAG FIXING
63	SPRING WASHER	
64	BRUSH BOX CARRIER	ASSEMBLY
65	CLAMPING PLATE	
66	SPRING WASHER	BRUSH BOX CARRIER
67	HEX. HEAD BOLT	RETAINING
68	BALL BEARING, UPPER	
69	BEARING RETAINING PLATE	
70	PLAIN WASHER	

screws (94) and shakeproof washers (95) securing each unit.

Removing the electrical connection

6. (1) The electrical connection should only be removed if there is evidence of damaged or overheated pins, or if there are signs of fuel leakage into the capacitor housing through the plug of sealing compound in which the electrical connection leads are set.

(2) Detach the electrical connection assembly by removing the six self-locking nuts (83). The plug will still be held in position by the sealing compound around the plug pin two lead assemblies (104). Use any suitable tool to remove this compound. Withdraw the electrical connection plug shell (85) from the pump body studs (90). Ignore any damage to the gasket (80).

(3) Remove the internal circlip (84) and release the positioning pin (89). Withdraw the pins (86 and 87) from the combs (88).

Removing the base filter assembly (fig. 1)

7. (1) Remove the four self-locking nuts (33) securing the base filter assembly (37). Remove the filter together with the vapour guide cone (39), the four pillars (32) and springs (38).

Removing the motor outer casing assembly

8. (1) Remove the three self-locking nuts (50) and plain washers (51) from the bolts (52A-1 off) and (52-2 off) securing the motor outer casing assembly (8) to the pump casting.

(2) Withdraw the casing carefully off the motor unit. Extract the cooling sleeve (14) from the outer casing.

RESTRICTED

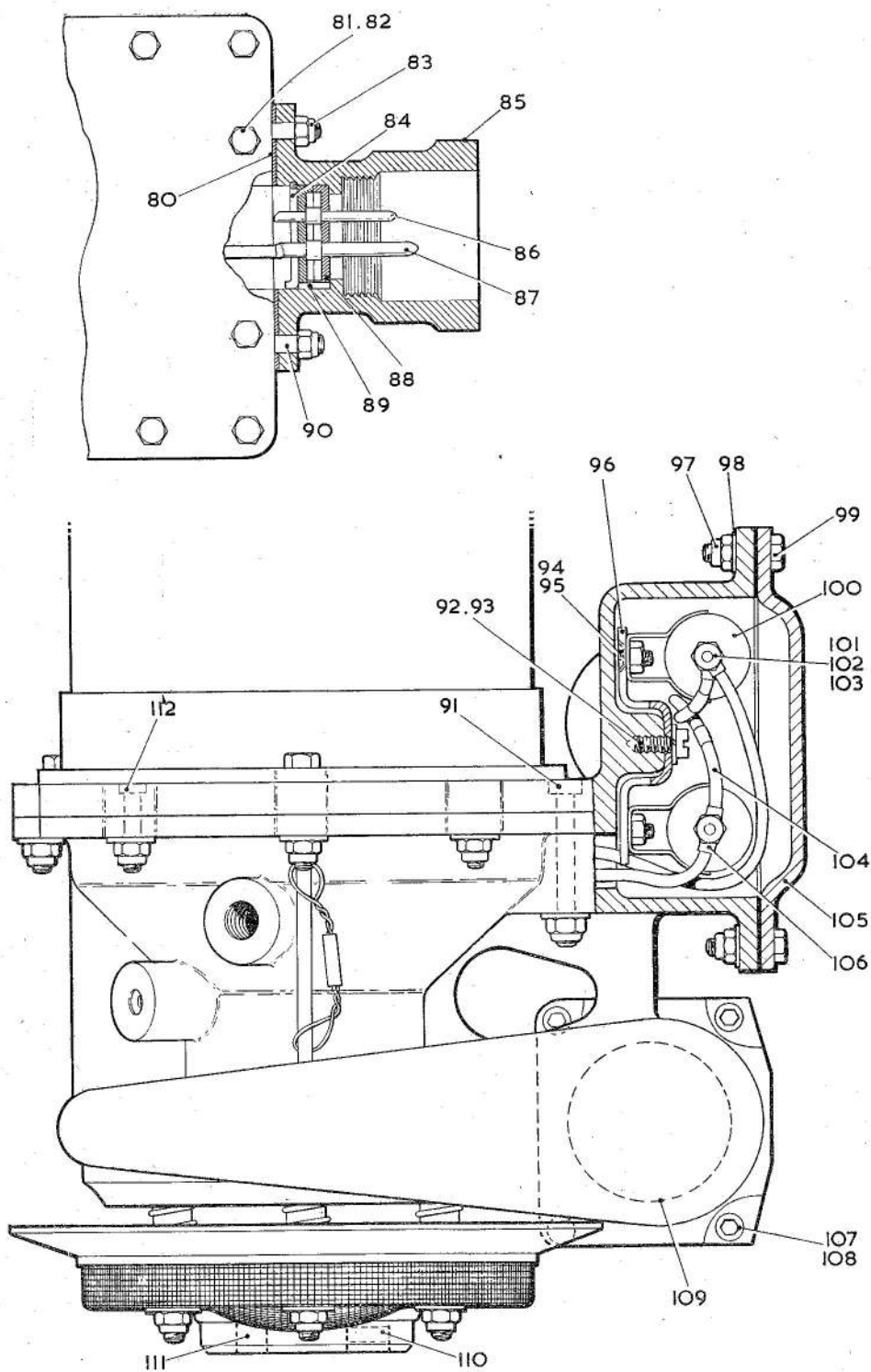

Fig. 2. Sectional view of suppressor housing and electrical connection

~~RESTRICTED~~

Key to Fig. 2

80 ELECTRICAL CONNECTION GASKET		95 CSK. SHAKEPROOF WASHER	} CAPACITOR FIXING
81 HEX. HEAD BOLT	} CAPACITOR COVER FIXING	96 CAPACITOR MOUNTING BRACKET	
82 SPRING WASHER			
83 SELF-LOCKING NUTS	} ELECTRICAL CONNECTION FIXING	97 SELF-LOCKING NUT	} CAPACITOR COVER FIXING
84 CIRCLIP			
85 PLUG SHELL		100 CAPACITOR UNIT	
86 7-AMP PIN		101 PLAIN WASHER	} CAPACITOR
87 19-AMP PIN		102 SHAKEPROOF WASHER	} TERMINAL
88 COMB		103 LOCKNUT	} ASSEMBLY
89 POSITIONING PIN		104 ELECTRICAL LEAD ASSEMBLY	
90 STUD (ELECTRICAL CONNECTION FIXING)		105 CAPACITOR COVER ASSEMBLY	
91 CAP SCREW, LONG (MOTOR FIXING)		106 TERMINAL TAG	
92 CHEESE HEAD SCREW	} CAPACITOR MOUNTING BRACKET	107 CAP SCREW	} OUTLET ASSEMBLY ATTACHING
93 SPRING WASHER			
94 CSK. HEAD SCREW		108 SELF-LOCKING NUT	
		109 GASKET	
		110 BREATHER PLUG ASSEMBLY	
		111 DRAIN TUBE	
		112 CAP SCREW, SHORT (MOTOR FIXING)	

Removing the helical and centrifugal impellers

9. (1) Holding the impeller helix (27B) to prevent the armature spindle rotating, unscrew and remove the lower spindle end nut (35) and washer (34). Withdraw the helix (27B) off the spring dowel (42) and remove any adjusting shims (26) that may be fitted.

Note . . .

The impeller helix (27B) and centrifugal impeller (27A) together form a paired and balanced assembly. If more than one pump is being dismantled simultaneously, identify the helix with the pump assembly from which it has been removed so that it can be paired later with the correct centrifugal impeller.

- (2) Remove the six cheesehead screws (30) and spring washers (31) securing the helix shroud (40) to the pump body casting. Withdraw the helix shroud together with any adjusting shims (41) fitted.
- (3) Withdraw the centrifugal impeller (27A) using the special extractor tool SPE.19538 (fig. 5), together with any adjusting shims (25) fitted. Do not remove the spring dowel (42) unless damaged.

- (4) Remove the spring (22) and rotary seal ring (21), and, if free, remove the stationary seal ring (45) and packing (20). Remove and discard the seal ring (44).

Removing the lower bearing housing

10. (1) Remove the four cheesehead screws (23) and shakeproof washers (24) securing the seal (lower bearing) housing (43) to the pump body casting. Use 4-B.A. screws in the tapped flange holes to assist in withdrawing the seal (lower bearing) housing (43) from the pump body casting. Remove and discard the seal ring (46). If not already removed, press out the stationary seal ring (45) and discard the seal ring (20).

Separating the motor unit from the pump body casting (fig. 1 and 2)

11. (1) Remove the six self-locking nuts (50) and plain washers (51) from the five cap screws (112) and one cap screw (91), then remove the cap screws. Support the motor unit, which is now free in the pump body casting.
- (2) Ease the motor unit assembly out of the pump casting, taking care not to damage the field leads when pulling them back through the casting conduit.

RESTRICTED

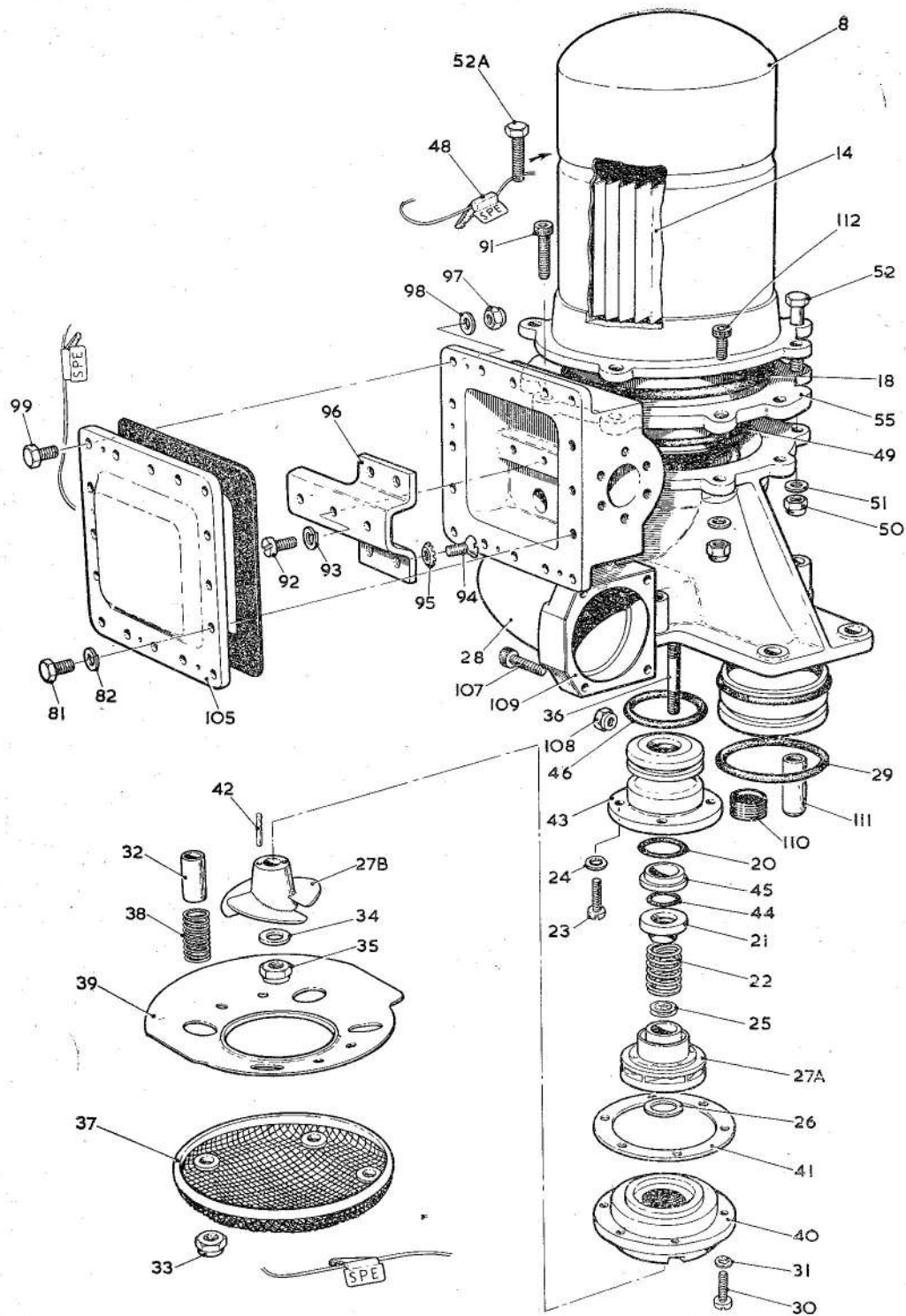

Fig. 3. Exploded view of pump unit

RESTRICTED

Key to Fig. 3

8	MOTOR OUTER CASING ASSEMBLY	
14	COOLING SLEEVE	
18	SEAL RING, MOTOR	
20	STATIONARY SEAL RING PACKING	
21	ROTARY SEAL RING	
22	SPRING	
23	CHEESE HEAD SCREW	} SEAL HOUSING
24	SHAKEPROOF WASHER	
25	IMPELLER ADJUSTING SHIMS	
26	HELIX ADJUSTING SHIM	
27A	IMPELLER	
27B	HELIX	
28	PUMP BODY CASTING	
29	SEAL RING, LOCATING PLUG	
30	CHEESE HEAD SCREW	} HELIX SHROUD
31	SPRING WASHER	
32	FILTER PILLAR	
33	SELF-LOCKING NUT	
34	PLAIN WASHER	
35	SPINDLE END NUT, LOWER	
36	STUD, FILTER SECURING	
37	BASE FILTER ASSEMBLY	
38	FILTER SPRING	
39	VAPOUR GUIDE CONE	
40	HELIX SHROUD	
41	HELIX SHROUD ADJUSTING SHIMS	
42	SPRING DOWEL	
43	SEAL HOUSING	
44	ROTARY SEAL RING PACKING	
45	STATIONARY SEAL RING	
46	SEAL RING	
47	THROWER NUT SEAL RING	
48	LOCKING WIRE SEAL	
50	SELF-LOCKING NUTS	} MOTOR OUTER CASING
51	PLAIN WASHER	
52A	SPECIAL BOLT	} MOTOR OUTER CASING
52	HEXAGON HEAD BOLT	
55	MOTOR END CASING, LOWER	
81	HEXAGON HEAD BOLT	} CAPACITOR COVER
82	SPRING WASHER	
91	CAP SCREW, LONG	
92	CHEESE HEAD SCREW	} CAPACITOR MOUNTING BRACKET
93	SPRING WASHER	
94	C/SUNK HEAD SCREW	} SECURING CAPACITOR MOUNTING BRACKET
95	C/SUNK SHAKEPROOF WASHER	
96	CAPACITOR MOUNTING BRACKET	
97	SELF-LOCKING NUT	} CAPACITOR COVER
98	PLAIN WASHER	
99	BOLTS	
105	CAPACITOR COVER ASSEMBLY	
107	CAP SCREW	} OUTLET ASSEMBLY
108	SELF-LOCKING NUT	
109	GASKET	
110	BREATHER PLUG	
111	DRAIN TUBE	
112	CAP SCREW, SHORT	

Completing the dismantling of the pump body casting sub-assembly

12. (1) Remove and discard the seal rings (29) fitted in the external grooves of the mounting boss.
- (2) The breather plug assembly (110) need only be removed if the gauze appears damaged. Do not attempt to withdraw the copper drain tube (111).
- (3) Remove any studs (90) and (36) that are damaged.

Dismantling the motor unit*Disconnecting the field leads and removing the brushes*

13. (1) Remove and discard the two seal rings (18) and one seal ring (49) in the motor end casing (55).
- (2) Remove the four round head screws (59) and spring washers (60). Release the brush pigtail terminal tags and the brush pairing leads (61).
- (3) Remove the four round head screws (62) and spring washers (63)

securing the brush retaining plate and field lead tags to the brush box.

- (4) Mark the brushes (9) and brush boxes to enable each brush if re-used to be returned to its original box. Remove the brushes.

Removing the top motor end casing assembly

14. (1) Hold the thrower nut (19) with the special spanner SPE.16199 (fig. 5) and remove the armature spindle end nut (1) and stainless steel washer (70).
- (2) Remove the four tie-bolt nuts (6) or the motor tie-bolts (5) if the latter are unscrewed from the lower motor end casing (55) before the nuts slacken.
- (3) Withdraw the top motor casing assembly complete with the bearing and brush box assembly. Use a hide faced hammer, if necessary, to gently tap the casing free. Take care not to scratch the commutator or the brush holder when withdrawing the motor end casing.
- (4) Separate the yoke assembly (15) from the lower motor end casing (55)

RESTRICTED

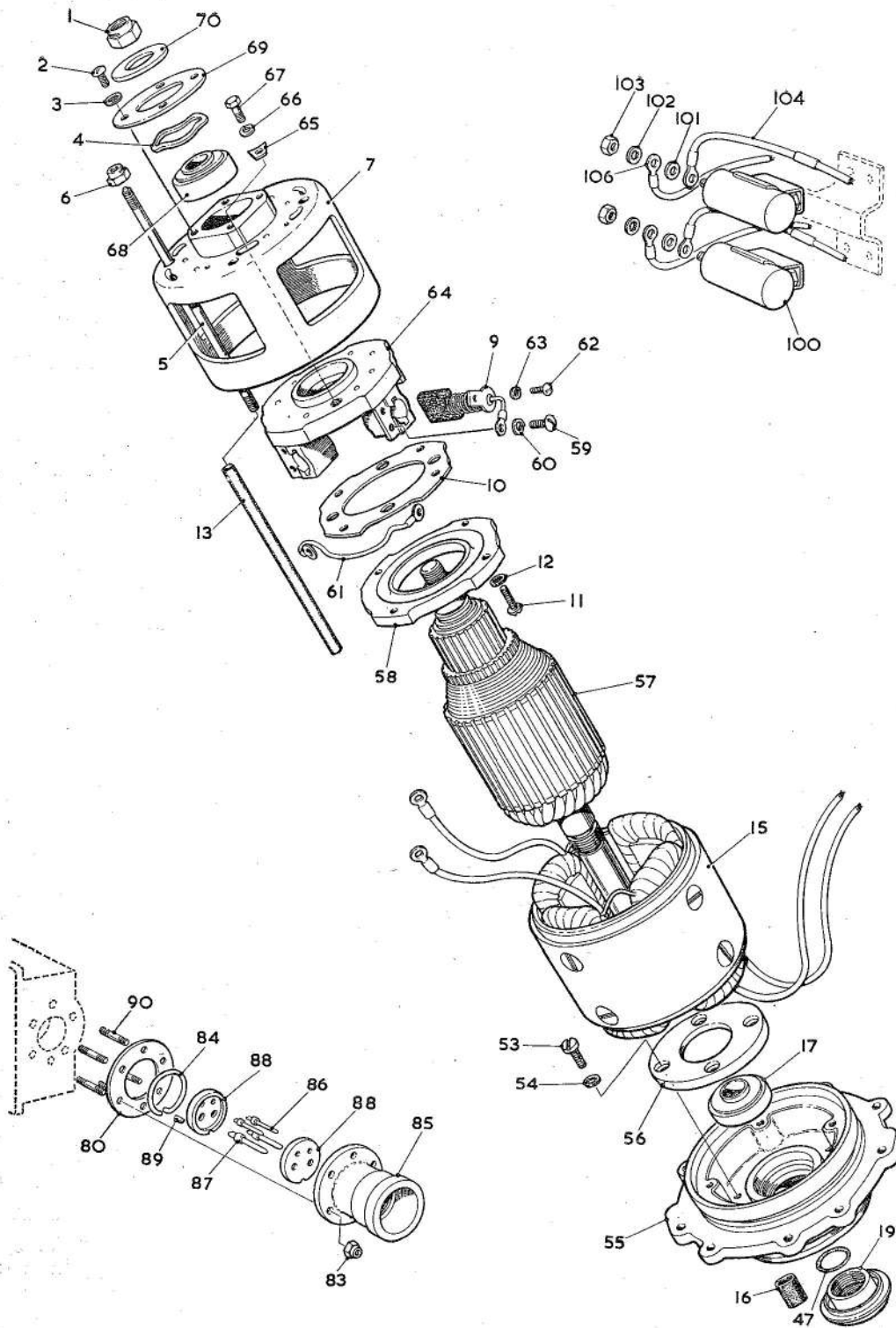

Fig. 4. Exploded view of motor unit
RESTRICTED

Key to Fig. 4

1 SPINDLE END NUT, UPPER		61 BRUSH PAIRING LEAD	
2 ROUND HEAD SCREW	} RETAINING PLATE	62 ROUND HEAD SCREW	} BRUSH RETAINING PLATE AND FIELD LEAD
3 SHAKEPROOF WASHER		63 SPRING WASHER	
4 BEARING PRE-LOAD WASHER		64 BRUSH BOX CARRIER	
5 MOTOR TIE BOLT		65 CLAMPING PLATE	} BRUSH BOX CARRIER
6 SELF-LOCKING NUT		66 SPRING WASHER	
7 MOTOR TOP END CASING		67 HEXAGON HEAD BOLT	
9 BRUSH ASSEMBLY		68 BALL BEARING, UPPER	
10 TERMINAL LEAD RETAINING PLATE		69 BEARING RETAINING PLATE	
11 ROUND HEAD SCREW	} LEAD HOUSING	70 PLAIN WASHER	
12 SHAKEPROOF WASHER		80 ELECTRICAL CONNECTION GASKET	
13 TIE BOLT INSULATING SLEEVE		83 SELF-LOCKING NUT	
15 YOKE ASSEMBLY		84 CIRCLIP	
16 RUBBER SLEEVE		85 PLUG SHELL	
17 BALL BEARING, LOWER		86 7 AMP. PIN	
19 THROWER NUT		87 19 AMP. PIN	
47 SEAL RING		88 COMB	
53 CHEESE HEAD SCREW	} LOWER BEARING RETAINING PLATE	89 POSITIONING PIN	
54 SHAKEPROOF WASHER		90 STUD	
55 MOTOR END CASING, LOWER		100 CAPACITOR UNIT	
56 LOWER BEARING RETAINING PLATE		101 PLAIN WASHER	
57 ARMATURE ASSEMBLY		102 SHAKEPROOF WASHER CAPACITOR TERMINAL ASSEMBLY	
58 TERMINAL LEAD HOUSING		103 LOCKNUT	
59 ROUND HEAD SCREW	} BRUSH PIGTAIL AND PAIRING LEAD	104 ELECTRICAL LEAD ASSEMBLY	
60 SPRING WASHER		106 TERMINAL TAG	

by withdrawing it carefully over the armature.

(5) Remove the insulation sleeving (13) from the tie bolts.

Dismantling the motor top end casing assembly

15. (1) Mark the position of the brush box carrier assembly (64) relative to the motor top end casing (7).

(2) Withdraw the brush box carrier assembly (64) by removing the two hexagon-head bolts (67), spring washers (66) and clamping plates (65).

(3) Remove the four round-head screws (2) and shakeproof washers (3) securing the bearing retaining plate (69). Withdraw the bearing pre-load washer (4) and press the bearing (68) out of its housing.

Dismantling the brush box assembly

16. (1) Remove the four round-head screws (11) and shakeproof washers (12) securing the terminal lead housing (58) and retaining plate (10) to the brush box carrier assembly (64).

(2) Release the flexible brush pairing leads (61).

Dismantling the motor lower end casing assembly

17. (1) Hold the armature assembly (57) and using the special spanner SPE. 16199 (fig. 5) release the thrower nut (19). Remove and discard the seal ring (47).

(2) Remove the four cheese head screws (53) and shakeproof washers (54) securing the bearing retaining plate (56).

(3) Press out the bearing (17).

CLEANING, EXAMINATION AND REPAIR

Cleaning

18. Immerse the armature and field assembly in white spirit and use a soft bristle brush to dislodge carbon deposits. After cleaning blow off the surplus spirit and allow the components to dry out for several hours. Complete the drying in a ventilated oven at approximately 93°C.

RESTRICTED

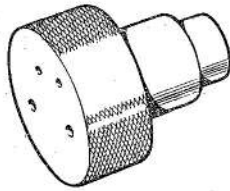

PIN LOCATING SPIGOT.
S P E 20680

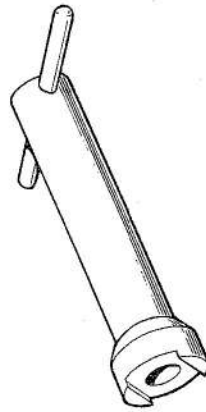

THROWER NUT SPANNER.
S P E. 16199

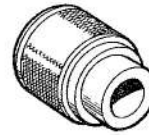

CENTRALISING GAUGE.
(LOWER BEARING)
S P E. 19539

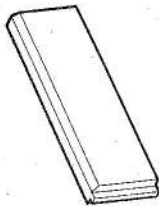

ARMATURE LOCKING STRIP.
S P E. 20684

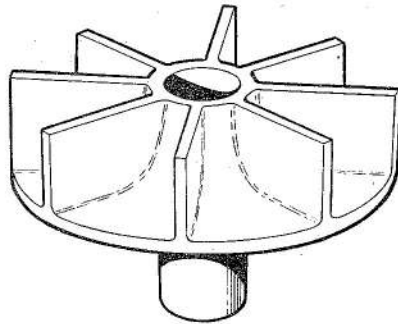

TORQUE TEST FAN.
S P E. 16051



EXTENSION SHAFT
S P E. 19542

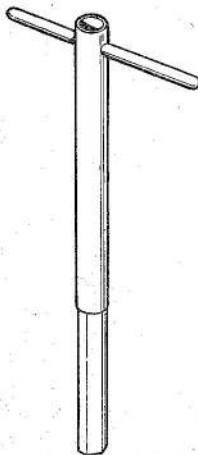

EXTENDED ALLEN KEYS. { 2 B.A. S P E 20683
4 B.A. S P E 20682

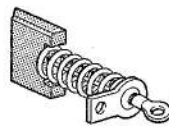

PENCIL BRUSH
S P E. 16200

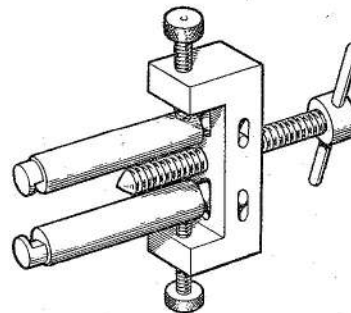

IMPELLER EXTRACTOR.
S P E. 19538

Fig. 5. General tools

~~RESTRICTED~~

Ensure that all dried jointing compound is removed from mating pump component surfaces, using an approved remover, if necessary. All parts excepting the electrical connection, bearings and synthetic material or rubber components should be cleaned in a dry-cleaning solvent, or if excessively dirty, in a heavy duty degreasant. After cleaning allow to dry out for 12 hours and complete the drying in a ventilated oven at approximately 93°C.

Examination

General

19. Examine all metal components visually for cracking, cleanliness, distortion, scoring, denting, evidence of wear, deterioration of protective finishes (corrosion),

serviceability of threads, security of sub-assemblies not normally dismantled (riveting, etc.) and discolouration due to overheating. Examine re-usable rubber components and electrical cable insulation for cleanliness, chafing, cuts, cracking, overheating, fluid soakage and general deterioration. All seal rings must be renewed on re-assembly. It is also recommended that the bearings are renewed whenever the pump is reconditioned.

Detailed procedure

20. Parts should be examined in accordance with Table 2 and checked for conformity with the schedule of Fits, Clearances and Repair Tolerances given in Table 3.

TABLE 2

Detailed examination of components

Item	Examination	Action if faulty
Armature	Insulation resistance to shaft. Use a 500 volt insulation resistance tester.	Clean thoroughly using white spirit. Dry for a prolonged period at 93°C. Allow armature to cool. Check that insulation resistance is not less than 50 megohms. If below this figure continue drying process. Cool. Re-check.
	Commutator for loose conductors.	Reject for re-winding.
	Commutator for scoring and burnt segments.	Skim commutator. Minimum permissible diameter for further use is 30.0 mm. (1.181 in.) dia. Clean out slots with thin blade. Check that no copper burrs are shorting across mica between segments. Commutator to be true with spindle to within 0.001 in. total clock reading when rotated on journals.
	Fouling of armature on poles.	Check spindle for concentricity and side-play of bearings.
	Short or open circuited conductors. Use voltage drop tester or growler.	Clean undercutting on commutator. If still unsatisfactory, reject armature.
Armature spindle for concentricity.	Maximum eccentricity 0.025 mm. (0.001 in.). If excessive, reject.	

~~RESTRICTED~~

TABLE 2—(contd.)

Item	Examination	Action if faulty
Field.	<p>Charring or other evidence of overheating.</p> <p>Total resistance of windings measured and corrected to 20°C—62.72 ohms.</p> <p>Condition of field coils.</p> <p>Insulation resistance of coils to frame.</p> <p>Condition of field coil lead coverings.</p>	<p>Renew complete assembly.</p> <p>Renew complete assembly.</p> <p>If damaged, renew complete assembly.</p> <p>Clean thoroughly using white spirit (para. 18). Dry for prolonged period at 93°C. Allow to cool. Check that the insulation resistance reading is not less than 50 megohms. If below this figure, continue drying process. Cool. Re-check.</p> <p>If damaged, cover with additional sleeving.</p>
Brush gear	<p>Spring loading to give 5 lb/in.² (351 gm./cm.²) \pm 7½% at 0.719in. (18.3 mm.) overall dimension between retaining plate and end of brush. 5.0 mm. carbon wear allowed for.</p>	<p>If springs or pigtail lead are damaged or broken, renew brush assembly.</p>
Bearing pre-load washer.	<p>Load between 11.5 and 14.0 lb. (5.2/6.34 kg.) to compress washer to 0.059 in. (1.5 mm.) overall thickness.</p>	<p>Renew.</p>
Seal unit	<p>Scoring of seal faces.</p>	<p>If slight, relap to a mirror finish. If excessive, renew.</p>
Filter Assy.	<p>Damaged wire mesh.</p>	<p>Renew.</p>
Electrical connection	<p>Damaged pins.</p>	<p>Renew as necessary.</p>
Gaskets and joint rings.	<p>Renew during reconditioning.</p>	<p>Renew.</p>
Bearings	<p>It is recommended that new ball bearings are fitted when reconditioning the pump.</p>	
Lower bearing	<p>Examine carbon for signs of cracks and damage.</p>	<p>Renew complete seal housing (lower bearing).</p>
Capacitor units	<p>Each capacitor should be checked individually with a 250-V constant pressure insulation resistance tester. The insulation resistance between terminal and earth to be not less than 50 megohms.</p>	<p>Renew.</p>

~~RESTRICTED~~

TABLE 3
Schedule of fits, clearances and repair tolerances

Part and Description	Dimensions New	Permissible worn dimen- sions for further use	Clearance New	Permissible worn clearance for re-use	Remarks
MOTOR UNIT					
BRUSH LENGTH—OVERALL LENGTH	11.9 mm (0.469 in.)	6.9 mm. (0.272 in.)	—	—	—
COMMUTATOR	31.100 mm. (1.224 in.)	—	—	—	—
diameter	31.300 mm. (1.232 in.)	30 mm. (1.181 in.)	—	—	—
ARMATURE END FLOAT	—	—	0.15 mm. (0.006 in.) (max.)	0.225 mm. (0.009 in.)	—
ARMATURE SPINDLE IN LOWER BALL-BEARING	11.995 mm. (0.4723 in.)	—	—	—	Inner race clamped to spindle on both faces. Selective as- sembly.
diameter	11.985 mm. (0.4719 in.)	—	—	—	
bore	12.000 mm. (0.4724 in.)	—	—	—	Inner race clamped to spindle on both faces. Selective as- sembly.
ARMATURE SPINDLE IN COMMUTATOR-END BALL RACE	11.995 mm. (0.4723 in.)	—	—	—	
diameter	11.985 mm. (0.4719 in.)	—	—	—	—

RESTRICTED

~~RESTRICTED~~

Part and Description	Dimensions New	Permissible worn dimen- sions for further use	Clearance New	Permissible worn clearance for re-use	Remarks
bore	12-000 mm. (0-4724 in.) <hr/> 11-990 mm. (0-4721 in.)				
CLEARANCE BETWEEN THROWER NUT AND LOWER MOTOR END CASING	—	—	0-127 mm. (0-005 in.)	—	—
PUMP UNIT					
CLEARANCE BETWEEN IMPELLER AND SEAL HOUSING (dim. A, Fig. 6)	—	—	0-650 mm. (0-026 in.) <hr/> 0-350 mm. (0-014 in.)	—	Adjust by shimming as detailed in para. 41.
CLEARANCE BETWEEN IMPELLER SHROUD AND CENTRIFUGAL IMPELLER (dim. B, Fig. 6)	—	—	0-250 mm. (0-010 in.) <hr/> 0-150 mm. (0-006 in.)	—	Adjust by shimming as detailed in para. 45.
PROTRUSION OF HELIX BEYOND END OF IMPELLER SHROUD (dim. C, Fig. 6)	—	—	1-000 mm. (0-40 in.)	—	Adjust by shimming as detailed in para. 46.

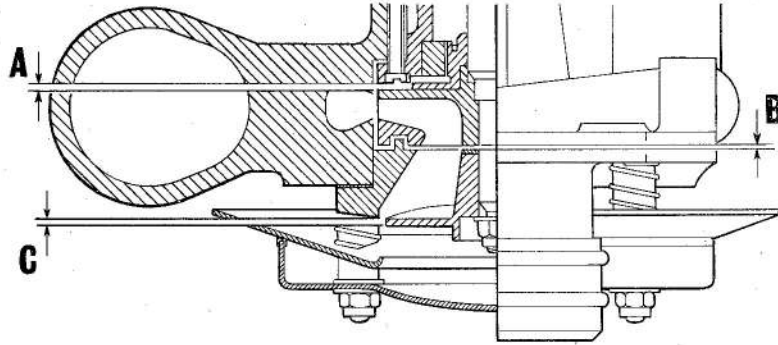

Fig. 6. Fits and clearances diagram

ASSEMBLING

General

21. Preserve absolute cleanliness of the work bench and tools throughout the assembly of the pump. Retain the bearings in their wrappings until they are required for assembly. Always use the special tools provided where specified.

Motor unit

Assembling the lower motor end casing
(fig. 1)

22. (1) Pre-select a new bearing (17) that is a slide fit under thumb pressure both on the armature spindle (57) and in the lower motor end casing (55). Retain the armature assembly and end casing and suitably mark both so that they can be paired with the selected bearing at a later assembly stage. Check that the selected bearing is smooth running with no roughness when the inner race is rotated by hand.

(2) Check that the bearing housing in the lower motor end casing (55) is perfectly clean and that the wall surface is smooth and free of score marks, burrs, and adhering swarf. Insert the selected bearing. Fit the bearing retaining plate (56) over the bearing and secure with four cheesehead screws (53) and shakeproof washers (54).

Assembling the brush gear

23. (1) Place the two flexible brush pairing leads (61) in position in the recess of the terminal lead housing (58).

(2) Position the terminal lead retaining plate (10) over the housing and bring a flexible lead (61) tag through each hole in the plate. The end tags of each lead assembly should be brought out of diametrically opposite plate holes.

(3) Position the brush box carrier assembly (64) over the lead retaining plate and secure together with four 6-B.A. round head screws (11) and shakeproof washers (12).

(4) Secure each flexible lead assembly tag to a brush box in position nearest to the lead housing (58) with a 6-B.A. round head screw (59) and spring washer (60).

Assembling the top motor end casing

24. (1) Position the brush gear sub-assembly (as para. 23) in the motor top end casing (7) aligning the marks made during dismantling. Secure with two hexagon head bolts (67), spring washers (66) and the clamping plates (65). Do not fully tighten the bolts at this stage.

(2) Pre-select a bearing (68) that is a slide fit under thumb pressure both on the armature assembly (57) and in the motor top end casing (7) housing. Suitably mark the armature and the motor top end casing so that they can be paired with the selected bearing at a later assembly stage. Check that the selected bearing is smooth running

RESTRICTED

with no roughness when the inner race is rotated by hand.

(3) Check that the bearing housing in the motor top end casing is clean and that the wall surface is smooth and free of score marks, burrs, adhering swarf, etc. Insert the selected bearing, position the pre-load washer (4) and secure with the retaining plate (69), four round head screws (2) and shakeproof washers (3). Check that the pre-load washer is free and not trapped under the retaining plate.

Assembling the yoke, armature and end casing sub-assemblies

25. (1) If previously removed, refit the tie-bolts (5), screwing the shouldered end of each bolt into the motor lower end casing (55). Fit a 4.0 mm. i/dia. x 114.0 mm. long insulated sleeve (13) over each tie-bolt, ensuring that the sleeving covers the full length of the tie-bolt to within 0.125 in. of the upper thread and that it seats against the motor end casing.

(2) Insert the extended end of the selected armature (para. 22) through the motor lower end casing bearing. Fit a seal ring (47) in the internal groove of the thrower nut (19). Loosely assemble the thrower nut to the armature spindle using the special spanner SPE.16199 (fig. 5).

(3) Position the yoke assembly (15) over the four tie-bolts. Pass the two longer field leads through the slot in the motor lower end casing and locate the spigot of the yoke frame in the end casing. Visually align the edge slot in the motor frame with the alignment hole in the end casing. Take care not to damage or disturb the tie-bolt insulation sleeving when locating the yoke assembly.

(4) Align the motor top end casing assembly (para. 24) over the tie bolts so that the hole in the casing will align with the rim slot in the motor frame.

(5) Enter the armature spindle into the bore of the upper bearing, taking particular care not to scratch the commutator on the brush boxes. Locate the motor end casing over the spigot of

the motor frame, visually aligning the casing hole with the frame rim slot.

(6) Fit a self-locking nut (6) to each tie-bolt (5). Insert 0.125 in. diameter rods through the alignment holes in the motor end casings into the motor frame rim slots. Securely tighten the tie-bolt nuts. Withdraw the alignment rods.

(7) Place a plain washer (70) on armature spindle and secure with a self-locking nut (1). Hold the thrower nut (19) with the special spanner SPE.16199 (fig. 5) to tighten the spindle end nut.

(8) Holding the spindle end nut (1), securely tighten the thrower nut (19) using the special spanner SPE.16199 (fig. 5). Check that the clearance between the thrower nut and the motor lower end casing (55) is not less than 0.005 in. (0.127 mm.).

(9) Check that armature spindle eccentricity does not exceed 0.001 in. total indicator reading.

Pre-bedding the brushes

26. (1) Preferably using a slave motor, insert a brush (9) into each of the four brush boxes and secure with a round head screw (62) and spring washer (63).

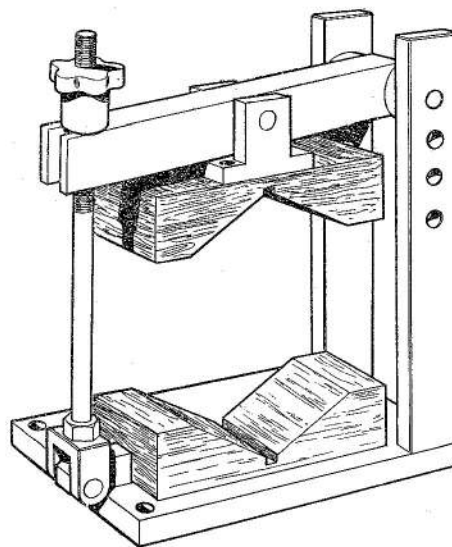

Fig. 7 Typical motor unit clamp

~~RESTRICTED~~

(2) With a strip of fine grade glass paper wrapped round the commutator, turn the armature by hand until the brushes are bedded over their full width of arc.

Preliminary brush bedding motor run

27. (1) Remove the brushes from the brush boxes of the slave motor, clean the faces with a small brush and transfer them to the motor unit being assembled. If the original brushes are being re-fitted, facilitate re-bedding by returning them to their original boxes, as indicated by the markings made during dismantling.

(2) Secure the brushes with 4-B.A. round head screws (62) and spring washers (63), connecting a field coil lead to each of two adjacent brushes. Remove the round head screws (59) and spring washers (60) securing the flexible brush pairing lead tags, and re-build each connection to include a brush pigtail tag.

(3) Run the motor unit at 20-22V d.c. without load and with the brush gear adjusted by means of the two bolts (67) to a position giving minimum sparking at the commutator. Continue running for approximately 3 hours or until the brushes bed over their full width of arc.

(4) Identify all four brushes with their boxes. Remove the brushes and retain for re-assembly at a later assembly stage. Replace the flexible lead securing screws (59) and spring washers (60).

Motor speed setting

28. (1) The motor speed should now be set by retarding the brush gear from its geometric neutral axis by 1.0 degree (+ 1.5, - nil degrees). To determine the geometric neutral axis proceed as follows: Isolate the field coils from the brush boxes and insert a special 'pencil' brush, SPE.16200 (fig. 5), in two adjacent brush boxes. Secure each with a 4-B.A. round head screw (62) and spring washer (63). Do not connect the brush pigtails or the field leads to the brush boxes. Clamp the motor unit in a bench clamp similar to that illustrated in fig. 7 to facilitate setting and retardation.

(2) Lock the brush gear and armature with the special locking strip SPE.20684 (fig. 5). This strip should be inserted in an unused brush box with the off-centre end ridge locating in a commutator slot. Hold in position.

Note . . .

The end ridge of the locking strip is machined to automatically give the one degree retardation required from the brush gear geometric neutral axis. It is important, therefore, that the correct locking strip for the SPE.1302 pump is used; similar components used in the assembly of other motors, having the same brush box assembly as the SPE.1302, must not be used.

29. Use one of the following methods to determine the geometric neutral axis.

Method 1

(1) Connect up the circuit as shown in fig. 8.

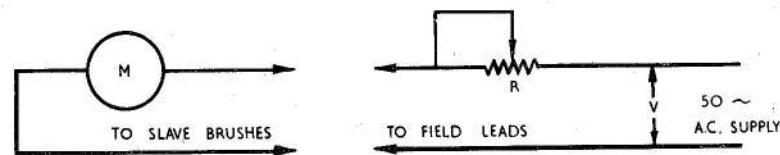

V: 20V maximum.

M. low reading a.c. millivoltmeter or microammeter.

R: variable swamp resistor to limit pointer deflection to the maximum scale reading.

Fig. 8. Brush gear setting, Circuit Diagram 1

RESTRICTED

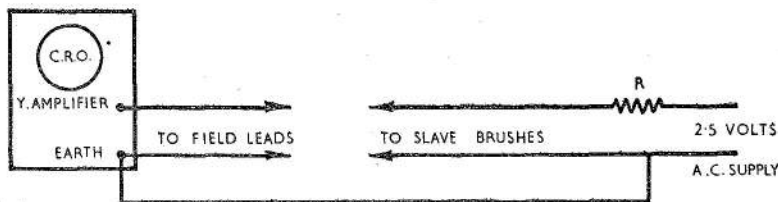

R: 3 ohm wire wound resistor.

Fig. 9. Brush gear setting, Circuit Diagram 2

(2) Slacken the brush gear securing bolts (67) and rotate the brush box until a zero reading is obtained on the meter (M). Continue the rotation until the meter reading increases, reverse the direction of rotation and continue until a true zero reading is obtained. Do not release the hold on the locking strip during this operation. Mark the relative position of the brush box carrier to the motor top end casing.

Method 2

- (1) Connect up the circuit as illustrated in fig. 9.
 - (2) Switch the oscilloscope time base to a frequency much higher than the 2.5V supply frequency, so that a rectangular trace is obtained on the cathode ray tube. Slacken the brush gear securing bolts and rotate the brush gear and armature carefully so that the trace attains a maximum amplitude (vertical displacement) or overload. Manipulate the 'Y' amplifier gain control, bringing the amplitude of the trace to just below overload. If the overload trace is not obtained, set the 'Y' amplifier at full gain and leave the oscilloscope at this setting. Rotate the brush gear and armature until the narrowest possible horizontal line appears on the cathode ray tube. Continue rotation until the width of line increases, reverse the direction of rotation and continue until the narrowest possible line is again obtained. Mark the relative position of the brush box carrier (64) to the top motor end casing (7).
30. Rotate the armature through 90 degrees and determine the geometric neutral axis at the new position by the selected method described in para. 29. Mark the

motor end casing in line with the original datum on the brush box carrier. Repeat the method twice more at 90 degree intervals of commutator/armature relationship. Align the original datum mark on the brush box carrier with the mean of the four marks on the motor end casing. Tighten the brush box securing bolts and remove the locking strip and the special brushes.

31. Return the brushes removed after the preliminary brush bedding motor run to their original boxes as indicated by markings. Secure the brushes with 4-B.A. round head screws (62) and spring washers (63), connecting a field coil lead to each of two adjacent brushes. Remove the round head screws (59) and spring washers (60) securing the flexible brush pairing lead (61) tags, and re-build each connection to include a brush pigtail lead.

32. Run the motor unit without load for a minimum period of 10 hours at 20V d.c. input. After this run remove and examine each brush. Brushes must bed over their full width of arc with at least 80 per cent of their face area making contact with the commutator. The running of the motor should be continued until this degree of bedding is achieved for all brushes.

Caution . . .

Ensure that the brushes are returned after examination to their original brush boxes.

33. Instal the motor unit in a tank recess surrounded by a suitable coolant maintained at 20/25°C. (It is suggested that an outer motor casing (8) is set into the side wall of a small tank and the motor unit clamped into position). Using the calibrated fan SPE.16051 (fig. 5) or a suitable

~~RESTRICTED~~

dynamometer apply a torque of 44 oz. in. to the motor unit. Run the motor unit under this load for 30 minutes at 26V d.c. input. Check that the speed is 6500 r.p.m. minimum and that the current consumption does not exceed 16.5 amps.

34. Adjustment of the brush box from its retarded position to obtain a motor speed within acceptable limits is permissible to the extent of a further 1.5 degrees clockwise when viewed from the top motor casing end. Securely tighten the bolts (67) after this adjustment. Any adjustment necessary in excess of 1.5 degrees clockwise will reject the motor. No anti-clockwise adjustment is permissible.

Note . . .

1.5 degrees movement of the brush box represents an 0.036in. (0.9mm) movement measured at the outside edge of the glass paxolin brush box carrier (64).

Repeat the speed check after any adjustment.

35. Remove the motor unit from the tank fixture and while running under load make a visual check for absence of sparking at the brushes. Check the insulation resistance of the motor unit while it is warm using a 500 volt insulation resistance tester. The insulation resistance must not be less than 10 megohms.

Pump unit (fig. 1 and 2)

Sub-assembling the pump body casting

36. (1) If the electrical connection was removed at the dismantling stage, remove all sealing compound from the pump body casting (28). This compound can only be removed by scraping—not with solvents

(2) Check all the tapped holes in pump body casting for damaged threads. Replace any damaged studs (36) and (90).

(3) Replace the breather plug assembly (110). Peen metal into its slot to lock it in position.

Sub-assembling the electrical connection

37. (1) Locate the two 7-amp pins (86)

and two 19-amp pins (87) between the combs (88).

(2) Insert the pin sub-assembly into the plug shell (85) and position it with the pin (89). Retain the assembly with a circlip (84). Cut back the two 7-amp pins (86) flush with the flange face.

(3) Degrease the back face of the electrical connection shell (85) with acetone. Position a new gasket (80) on the shell flange.

(4) Lightly abrade the outer covering of the connection end of the cables (106) with fine sandpaper for approximately 1 in. length of insulation. Tin the ends of the leads and solder to the 19-amp pins (87) of the electrical connection leaving approximately $\frac{1}{4}$ in. bare wire between the end of the pin and the start of the insulation.

(5) Degrease the back face of the electrical connection shell, the gasket and the abraded length of cable insulation, using acetone. Ensure that the acetone does not contaminate the internal P.V.C. insulation of the cables. Stand sub-assembly aside in warm atmosphere for 15 minutes, to allow degreaser to evaporate.

(6) Degrease the capacitor box surfaces adjacent to the electrical connection using acetone. Stand aside in a warm atmosphere for 15 minutes.

(7) Secure the electrical connection to the studs of the pump body casting (28) with self-locking nuts (83). Do not touch degreased surfaces of capacitor housing.

(8) Mix the potting compound PR. 1422.BT (British Paints Ltd., Elastomers Division) in accordance with the instructions on the container. Avoid beating air into the compound during the mixing.

(9) Locate the locating spigot SPE. 20680 (fig. 5) over the pins of the electrical connection. Apply the potting compound to the back of the electrical

RESTRICTED

connection, pressing the mixture well down into the pump body casting hole, so that it flows around plug pins and leads. Finish across the surface of the capacitor box, (fig. 10), inclining the pump slightly so that the potting compound does not run out.

(10) Allow potting compound to cure for a minimum period of 24 hours (48 hours is preferable).

(11) Fit the adapter SPE.20679 (fig. 11) to the electrical connection and with the capacitor tag ends of the lead assemblies (106) immersed in water, apply air pressure at 10 lb./in.² through adapter. Observe for leakage of air from between the insulation layers of the leads; leakage is not permissible.

Assembling the motor unit to the pump body casting

38. (1) Fit a rubber sleeve (16) over the motor unit leads so that it butts right up to the motor end casing.

(2) Fit two new seal rings (18) and one new seal ring (49) to the grooves in the lower motor end casing.

(3) Re-check armature spindle for concentricity. Total eccentricity reading must not exceed 0.001 in. when measured near the end of the spindle.

(4) Lightly smear the seal rings with Silicone MS.4 compound A.339, Ref. No. 33C/9424829. Check that motor unit location surfaces in the pump body casting are clean. Thread motor unit leads through channel in casting and locate the motor unit, aligning the flange fixing holes. Secure initially in three positions only with cap screws (112), plain washers (51) and self locking nuts (50) using special key SPE.2082 (fig. 5) to hold screws.

Assembling the lower bearing (seal housing) assembly

39. (1) Fit a new seal ring (46) in the external groove of the lower bearing (seal housing) assembly (43), lightly smear with grease, see para. 38 (4). Fit a new seal ring (20) to the stationary seal ring (45) and locate this sub-assembly in the seal housing (43). Check that the seal ring (20) is not

displaced and that it is seating squarely against the internal shoulder of the seal housing.

(2) Clean the bore of the pump body casting (28) and fit the lower bearing (seal housing) assembly. Secure with the four cheesehead screws (23) and shakeproof washers (24).

(3) With a clock gauge mounted to the extension shaft SPE.19542 (fig. 5) check the concentricity of the lower bearing surface in relation to the armature spindle. Eccentricity must not exceed 0.002 in. total indicator reading.

(4) If the concentricity requirements are not met, remove the screws (23) and rotate the seal housing through 90 degrees. Secure and recheck.

(5) When satisfactory, securely tighten seal housing screws (23), and fit the remaining two cap screws (112) and

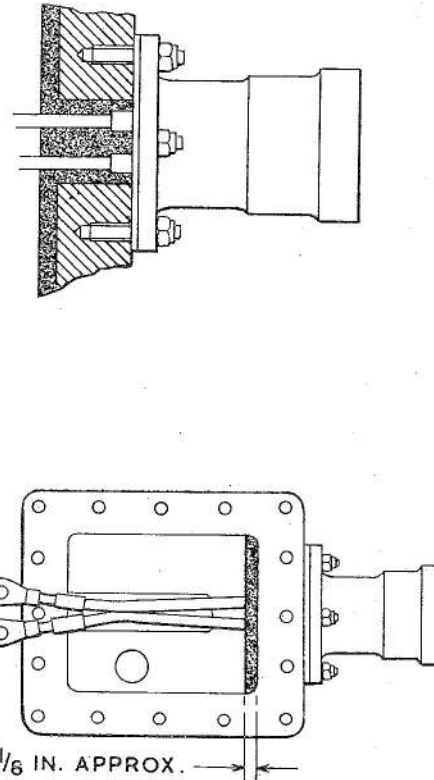

Fig. 10. Electrical connection sealing: instruction diagram

~~RESTRICTED~~

one cap screw (91) with plain washers (51) and self-locking nuts (50), to secure the motor unit to the pump body casting.

(6) Use the centralising gauge SPE.19539 (fig. 5) to re-check the concentricity of the armature spindle and lower pump bearing. This gauge must drop freely into position.

Fitting the outer motor casing

40. (1) Fit the cooling sleeve (14) inside the outer motor casing (8) so that it seats on the internal base flange of the casing.

(2) Secure the outer motor casing to the pump body casting with two hexagon head bolts (52), one bolt (52A), plain washers (51) and self locking nuts (50). Note that the bolt (52A) should be assembled adjacent to the locking wire holes in a pump casting web.

Pre-assembling the centrifugal impeller

41. The pump unit must be fitted with a dynamically balanced impeller/helix sub-assembly (27). Components should have been paired during dismantling and the paired parts must now be assembled into the same pump unit. If more than one pump unit is being assembled, ensure that each components of the paired impeller/helix assembly is suitably marked, so that both are built into the same unit. Replacement components are supplied as balanced pairs only and should be assembled with the white location spot on the outer helix blade in line with the impeller dowel pin (42).

42. The centrifugal impeller (27A) must be correctly positioned with a gap of 0.014 in./0.026 in. (Dim. A, fig. 6) between its upper surface and the underside of the seal housing (43); set the gap as follows:—

(1) Using a depth micrometer measure the distance between the lower surface of the pump body casting (28) and the underside of the seal housing (43). Let this measurement be X.

(2) Measure the overall thickness of the selected impeller at its outer edge. Let this measurement be Y.

(3) Place shims (25) of 0.020 in. (0.5 mm.) total thickness on the spindle.

(4) Position the impeller. Fit distance piece SPE.19536 (fig. 11) over the armature spindle and tighten against the impeller with nut (35) and plain washer (34).

(5) Using the depth micrometer measure the distance between the lower surface of the pump body casting and the underside of the impeller. Let this measurement be Z.

(6) The clearance between the impeller (27A) and the seal housing (43) is given by $X - (Y + Z)$. If this clearance is not within the specified limits, increase or decrease the shims (25) and re-check the gap as in subpara. (4) and (5) above.

Assembling the seal

43. (1) Fit a new seal ring (44) in the internal groove of the rotary seal ring (21). Lubricate with a smear of Silicone MS.4 compound A.339 Ref. No. 33C/9424829. Do not allow any grease to get on to seal surface.

(2) Remove the impeller and retain the shims (25). Fit the spring (22) over the central spigot of the rotary seal ring (21) and ensure that it seats squarely against the flange.

(3) Locate the free end of the spring about the central spigot of the stainless steel impeller bearing, making sure that it bottoms in its seating.

(4) Refit the impeller shims (25) as previously selected. Assemble the rotary seal/impeller assembly carefully over the armature spindle until the rotary seal contacts the stationary (carbon) seal ring (45) previously positioned in the seal housing. Secure impeller with spacer SPE.19536 (fig. 11), plain washer (34) and self-locking nut (35).

~~RESTRICTED~~

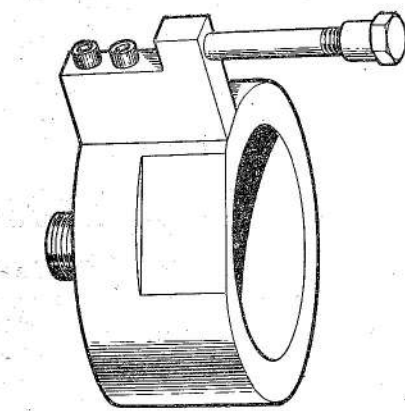

A PRESSURE TEST FIXTURE.
S P E. 17397

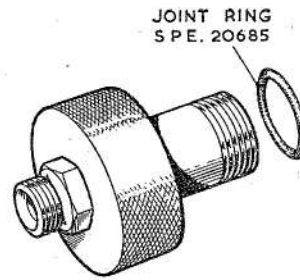

B PRESSURE TEST ADAPTOR.
S P E. 20679

JOINT RING
S P E. 20685

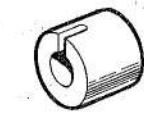

F DISTANCE PIECE.
(REPLACING HELIX.)
S P E. 19536

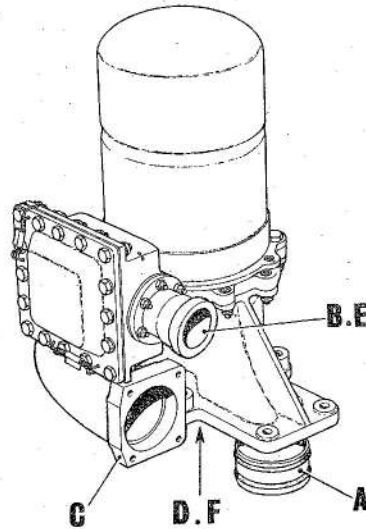

C PRESSURE TEST
CONNECTOR.
S P E. 17629.

GASKET,
S P E. 12283

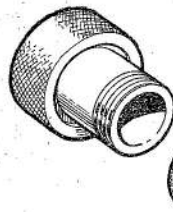
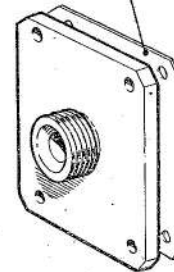

E PRESSURE TEST PLUG.
S P E. 17625.

JOINT RING
S.P.E. 20685

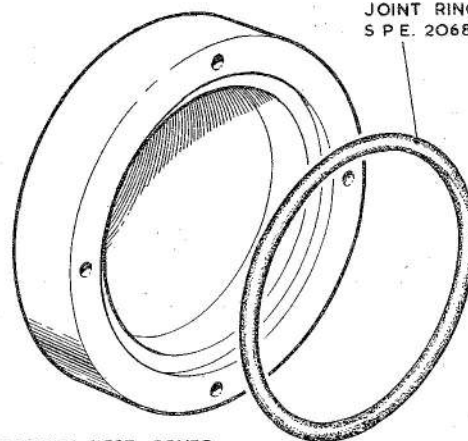

D PRESSURE TEST COVER
S P E. 17628

JOINT RING
S P E. 20681

Fig. 11. Pressure test tools

RESTRICTED

(5) Set the depth micrometer to just touch the lower surface of the impeller. Rotate the impeller and check variations in the micrometer reading at 90° intervals. Repeat this check with the micrometer set on different diameters. Maximum overall "out-of-square" reading that is permissible is 0.002 in.

Assembling the capacitors (fig. 2)

44. (1) Crimp 2-B.A. terminal tags (108) to the motor unit leads.

(2) Secure the two capacitors (100) to the capacitor mounting bracket (96) with two screws (94) and shakeproof washers (95). The capacitors should be fitted so that the terminals are towards the left when the mounting bracket is held with the capacitor fixing positions at the right hand side.

(3) Connect a motor lead and an electrical connection lead (104) to each capacitor terminal with a shakeproof washer (102) and locknut (103), spacing the tags with a plain washer (101).

(4) Retain the capacitor mounting bracket (96) with three cheesehead screws (92) and spring washers (93).

(5) Ensure that the leads clear the corners of the front diameter of each capacitor unit to avoid possible vibration damage in service.

(6) Check the insulation resistance between each capacitor terminal and frame using a 250V constant pressure insulation resistance tester. The reading measured should not be less than 50 megohms.

(7) Degrease the capacitor cover mounting surface of the pump casting. Allow to dry off. Secure the capacitor cover (105) with hexagon head bolts (81) and spring washers (82) in the three positions nearest to the electrical connection and with hexagon head bolts (99), plain washers (98) and self-locking nuts (97) in the remaining

thirteen flange positions. Use a torque spanner set at 15 in. lb. to tighten all the capacitor cover nuts and bolts.

Pressure testing the seal assembly

Note . . .

Refer to fig. 11 for the positioning of the various pressure test fixtures detailed in the following paragraphs.

45. (1) Fit a joint ring SPE.20681 in the pressure test cover SPE.17628 and attach cover to the base of the pump body casting with four 4-B.A. x 1" long screws and plain washers.

(2) Fit a gasket (109) and the pressure test connector SPE.17629 (fig. 11) to the delivery outlet of the pump body casting. Secure with four 2-B.A. x $\frac{3}{4}$ " screws and locknuts.

(3) Fit seal rings (29, fig. 1) in the two external grooves of the pump mounting boss and attach the pressure test fixture SPE.17397 by means of the single stud to the mounting boss flange.

(4) Fit a joint ring SPE.20685 in the pressure test plug SPE.17625 and screw the plug into the electrical connection. This plug is fitted to prevent fuel contamination of the plug pins during the pressure tests.

(5) Plug the two tapped bosses on the side of the pump body casting with (a) a $\frac{1}{4}$ " B.S.P. x 7/16" long hexagon head screw and bonded seal washer and (b) a 4-B.A. x $\frac{1}{4}$ " long screw and bonded seal washer.

(6) Connect up the air pressure line to the $\frac{3}{8}$ in. B.S.P. tapping on the delivery outlet pressure test connector SPE.17629. Gradually increase the applied air pressure from zero to 10 lb./in². Do not increase the applied air pressure suddenly as this may dislodge the gland components.

(7) Connect a rubber tube to the union on the pump mounting boss pressure test fixture SPE.17397. Im-

RESTRICTED

merse the free end of this tube in water or fuel. Observe for air leakage from this tube over a period of 5 minutes. A minute leakage only is permissible. Disconect the rubber tube.

(8) With the 10 lb./in.² air pressure still being applied through the pump delivery outlet, apply also an air pressure of 71lb./in.² through the $\frac{3}{8}$ in. B.S.P. union on the pump mounting boss pressure test fixture SPE.17397.

(9) Completely submerge the pump in a tank of AVTUR fuel and observe over a period of 5 minutes for air leakage at any part of the pump. None is permissible. If air leakage is apparent, the pump must be dismantled as necessary to rectify the fault. Repeat the full pressure test after re-building.

(10) Remove all pressure test fixtures.

Assembling the helix shroud

46. (1) Position the helix shroud (40) and using stainless steel adjusting shims (41) between the shroud and the pump body casting, adjust the gap between the shroud and the undersurface of the centrifugal impeller (27A) to 0.006 in./0.010 in. (Dim. B, fig. 6). Use a right-angle feeler gauge to measure this gap or alternatively use micrometers.

(2) Check that groove in impeller is unobstructed. Secure helix shroud with six cheese head screws (30) and special spring washers (31).

Assembling the impeller helix

47. Note . . .

The helix assembled into the pump must be that supplied with the impeller as part of a dynamically balanced sub-assembly.

(1) Remove the spacer SPE.19536 (fig. 11) and fit the impeller helix (27B). Use stainless steel shims (26) between the centrifugal impeller and the helix so that the leading edge of the helix blades project 0.040 in. (Dim. C, fig. 6) beyond the open end of the helix shroud (40). Note that the helix

(27B) must be assembled with the white location mark on a helix blade in line with the impeller assembly dowel pin (42).

Assembling the vapor guide cone and inlet filter

48. (1) Place a filter pillar (32) on each of the four studs (36) in the pump body casting. Fit a spring (38) over each pillar.

(2) Locate the vapour guide cone (39) over the filter pillars aligning the locking wire holes with that in the pump body casting.

(3) Thread a length of locking wire through the pump body casting and vapour guide cone.

(4) Position the inlet filter (37), threading the locking wire through the mesh. Twist the ends of the locking wire once only to retain.

(5) Secure the filter assembly with four self-locking nuts (33).

Testing and wire locking

49. (1) The pump is now ready for testing in accordance with the Schedule of Tests (para. 53-56). After satisfactory completion of these tests the assembly is to be wire-locked at the following positions:

(a) Pump body casting to capacitor housing cover.

(b) Outer casing fixing bolt to pump body casting web.

(c) At filter assembly, attach seal to wire fitted during pump unit assembly (para. 48).

Repair workshops should use their own seals for this purpose.

TESTING

General

50. The complete pump must be tested in accordance with the Schedule of Tests detailed in para. 53-56. The pump must be rejected if it fails to comply with these tests.

RESTRICTED

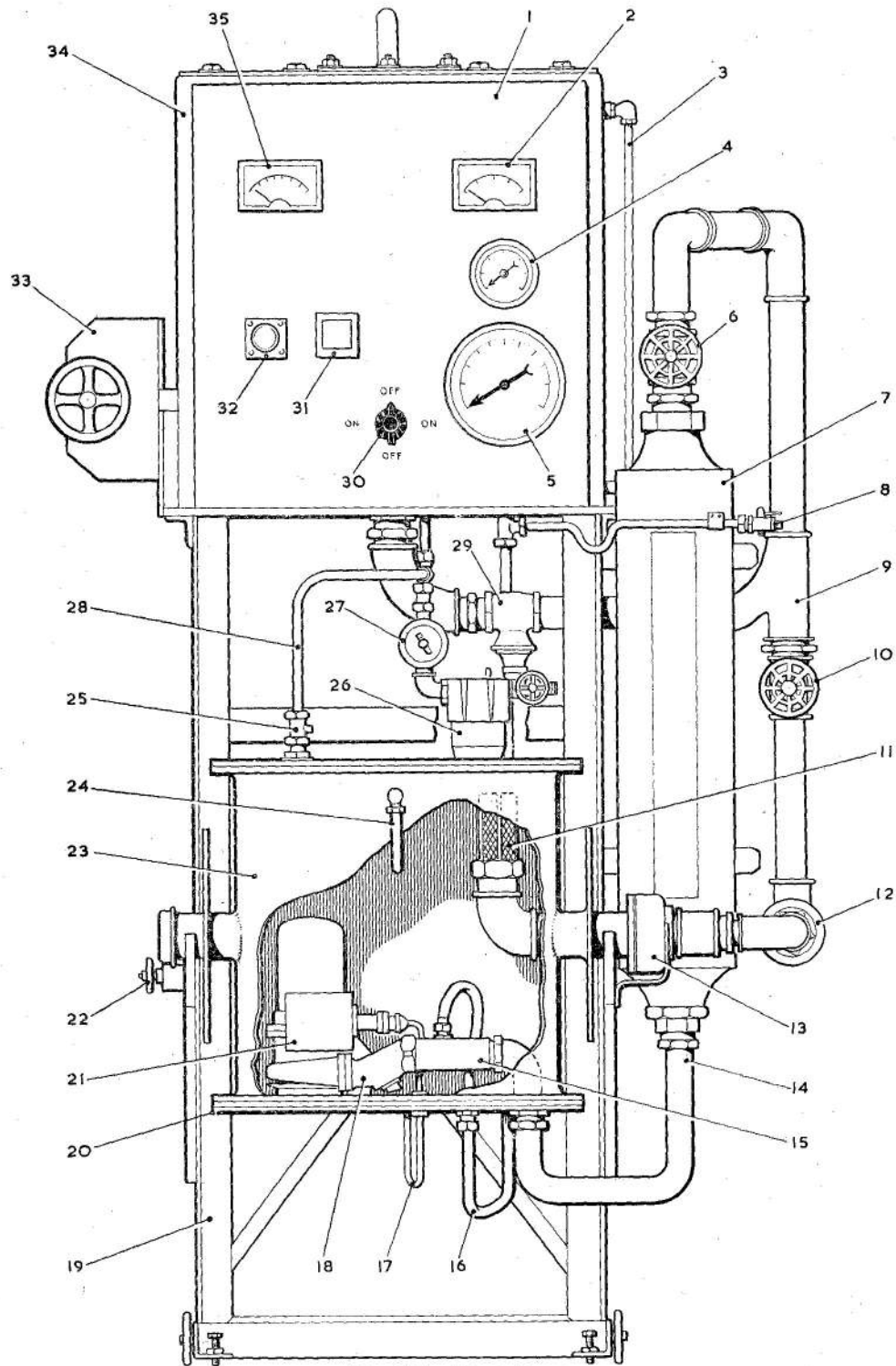

Fig. 12. Test rig

RESTRICTED

Key to Fig. 12

1 INSTRUMENT PANEL	19 FRAME
2 AMMETER (0-20A)	20 PUMP MOUNTING PLATE
3 HEADER TANK SIGHT GLASS	21 FUEL PUMP ON TEST
4 AIR PRESSURE GAUGE (0-30 lb./in.2)	22 TANK POSITIONING STOP
5 FUEL PRESSURE GAUGE (0-30 lb./in.2)	23 TEST TANK
6 FLOW REGULATING VALVE	24 SIGHT GLASS
7 FLOWMETER (0-2000 g.p.h.)	25 AIR RELIEF VALVE
8 PRESSURE CHECK CONNECTION	26 AIR FILTER
9 HEADER TANK INLET/OUTLET PIPE	27 AIR PRESSURE REGULATOR
10 FLOW REGULATING VALVE	28 AIR LINE
11 FUEL FILTER	29 FLOW REGULATING VALVE
12 NON-RETURN VALVE	30 ON/OFF SWITCH
13 GLAND	31 TEST SOCKET (3-PIN)
14 PUMP DELIVERY PIPE	32 ELECTRICAL CONNECTION PLUG
15 PRESSURE TAPPING CONNECTION	33 VARIABLE RESISTANCE
16 PRESSURE TAPPING PIPE	34 HEADER TANK
17 ELECTRICAL SUPPLY	35 VOLTMETER (0-40 V)
18 PUMP OUTLET	

Test equipment

51. A diagrammatic arrangement of a suitable type of test rig that could be used for SPE.1302 fuel booster pumps is illustrated in fig. 12. The universal test rig 5G/3494 may be used as an alternative if a suitable mounting adapter plate is available. Use AVTUR fuel for testing.

Preparation

52. (1) For all tests the outlet assembly SPE.17835 or SPE.17836 is to be fitted to the pump outlet. Secure with four cap screws (107) and self-locking nuts (108), fitting a gasket (109) between the two assemblies. Use special cap screw key SPE.20683 (fig. 5) to hold these screws when tightening locknuts.

(2) Fit seal rings in the external grooves of the pump location boss on the pump body casting (28). Bolt the pump to the tank mounting plate. Connect the electrical connection (which will be inside the test tank) and the delivery outlet pipe to the end of the connector assembly previously fitted (sub-para. (1)). Secure the tank mounting plate to the tank stud ring.

SCHEDULE OF TESTS

Starting test

53. With the pump fully submerged in fuel and the delivery valve closed apply 17.5V d.c. to the pump for a maximum time of three seconds. If the pump starts satisfactorily, switch off and repeat the check four times. If the pump fails to start, it must be rejected.

Gland leakage test

54. With the pump stationary and fully primed under a fuel head of 12 inches, apply a superimposed air pressure of 16 lb./in.² for 15 minutes. Repeat this test with 28V d.c. applied to the motor unit and with the test circuit delivery valve closed. During both tests observe for:—

(a) Fuel leakage from the gland drain.

(b) External fuel leakage.

The allowable maximum gland drain leakage during the stationary test is $\frac{1}{4}$ cc. and during the running period— $\frac{1}{2}$ cc. External leakage is not permissible.

Proof and calibration tests

55. (1) The pump is to be run for 1 hour with 26V d.c. applied, with the flow adjusted to 1200 gal./hr. The delivery pressure and motor current are to be recorded at the beginning and the end of the test, and must be within the limits specified in Table 4.

(2) With the pump running on an applied voltage of 26V d.c. the flow is to be adjusted from zero to 1800 gal./hr. in stages as follows: 0, 400, 800, 1200 and 1800 gal./hr. The delivery pressure and motor current are to be recorded at each flow stage and must be within the acceptance limits detailed in Table 4.

(3) With the pump running on an applied voltage of 25V d.c. the flow

~~RESTRICTED~~

is to be adjusted from zero to 1800 gal./hr. in stages as follows: 0, 400, 800, 1200 and 1800 gal./hr. The delivery pressure and motor current are to be recorded at each flow stage and must be within the acceptance limits detailed in Table 4.

(4) With the pump running on an applied voltage of 29V d.c. and the flow adjusted to 1200 gal./hr., record the delivery pressure and motor current at the beginning and end of a 1 hour test run. Recorded figures must be within the acceptance limits detailed in Table 4.

(5) With the pump running on an applied voltage of 29V d.c. the flow is to be adjusted from zero to 1800 gal./hr. in stages as follows:—0, 400, 800, 1200 and 1800 gal./hr. The delivery pressure and motor current are to be recorded at each flow stage and must be within the acceptance limits detailed in Table 4.

(6) Measure and record the insulation resistance using a 250 volt constant pressure insulation resistance tester. Insulation resistance must not fall below 2.0 megohms.

TABLE 4**Acceptance Limits: Proof and calibration tests**

V. d.c.	gal./hr.	lb.in. ²		Amps. max.
		max.	min.	
(1) 29.0	1200	—	16.0	17.25
(2) 29.0	0	26.0	—	—
(3) 26.0	0	21.5	18.5	16.5
(4) 26.0	1200	16.0	13.0	16.5
(5) 26.0	1800	10.0	7.0	16.5
(6) 25.0	1200	—	12.0	15.7

Dry test

56. The pump must be mounted clear of fuel and run for 5 minutes on an applied voltage of 29.0V d.c. The current consumption is to be recorded at the beginning and end of the test, and must not be greater than 6.0 amps finally.

Dismantling for inspection

57. This must be reduced to an absolute minimum in the case of a pump which has satisfactorily completed previous tests. No attempt should be made to break joints already thoroughly tested. Should the authorised inspector, however, consider a major strip for examination is necessary, the pump on rebuild must be subjected to a repetition of all the above tests (para. 53-56).

RESTRICTED

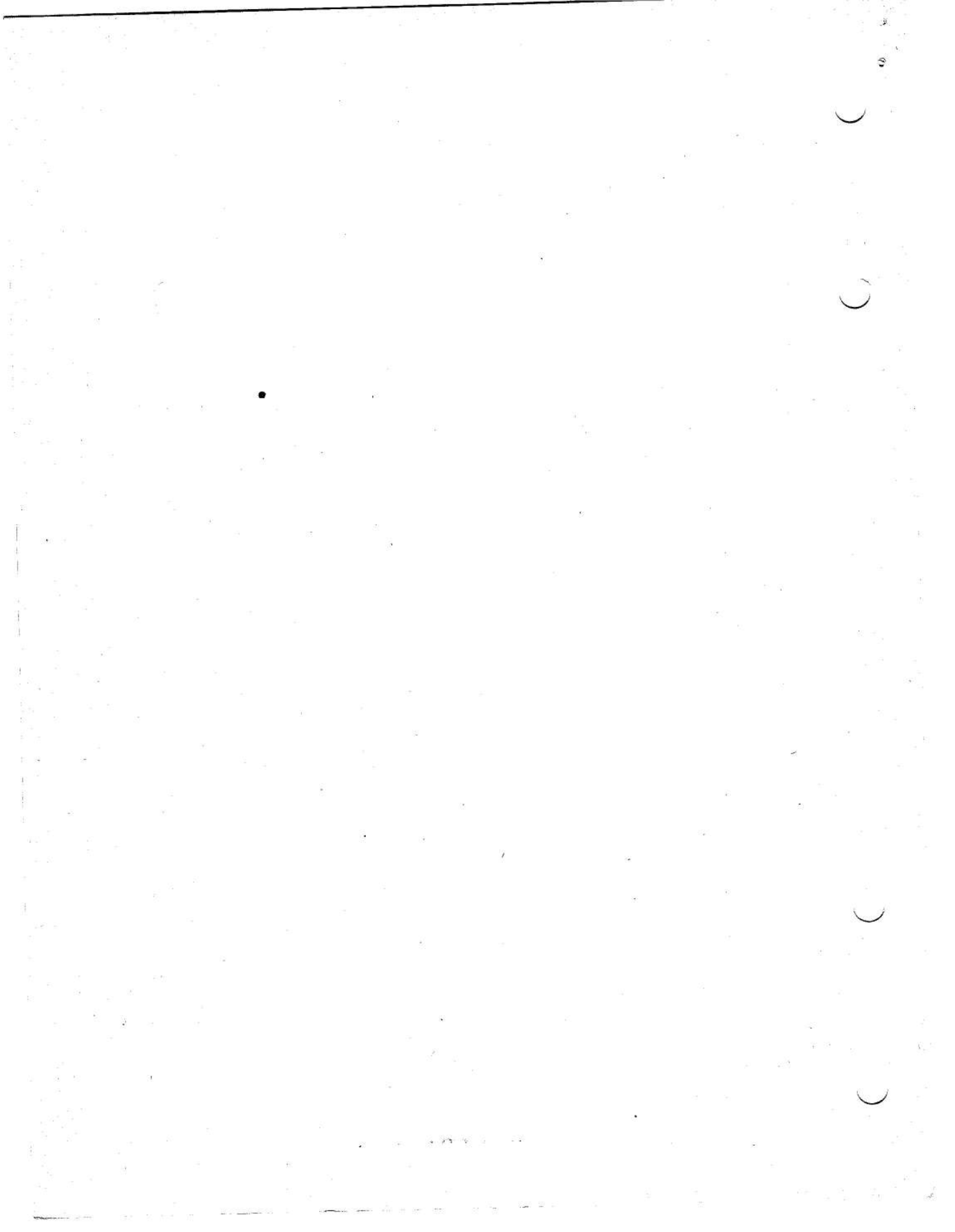

Appendix 1

RECONDITIONING SPE.1302 MK. 1 AND SPE.1302 MK. 2 FUEL PUMPS

General

1. In all cases SPE.1302 Mk. 1 and SPE.1302 Mk. 2 pumps returned for reconditioning should be re-built to the Mk. 3 standard detailed in the basic chapter. The conversions are relatively simple and detailed below:—

Note . . .

Instructions given apply at the date of issue of this appendix. Introduction of modifications affecting the Mk. 3 pump and not necessarily applicable to earlier marks, will tend to increase the difference between the Mk. 1 or Mk. 2 pump and the Mk. 3 version.

Reconditioning an SPE.1302 Mk. 1 pump

2. Dismantle in exactly the same sequence as detailed in the basic chapter for the Mk. 3 pump, but ignore references to the

removal of the sealing compound behind the electrical connection within the capacitor housing. Discard the gland spring. Re-assemble to Mk. 3 standard exactly as detailed in the basic chapter, replacing the Mk. 1 gland spring with the new component (22, fig. 1). Cut back the 7 amp. pins (86, fig. 2) of the electrical connection, flush with the flange of the plug shell (85). Use a new Mk. 3 gasket (80).

Reconditioning an SPE.1302 Mk. 2 pump

3. Dismantle in exactly the same sequence as detailed in the basic chapter for the Mk. 3 pump, but ignore reference to the removal of the sealing compound used behind the electrical connection within the capacitor housing. Re-assemble to Mk. 3 standard exactly as detailed in the basic chapter, cutting back the 7-amp. pins (86, fig. 2) of the electrical connection flush with the flange of the plug shell (85). Use a new Mk. 3 gasket (80).

~~RESTRICTED~~

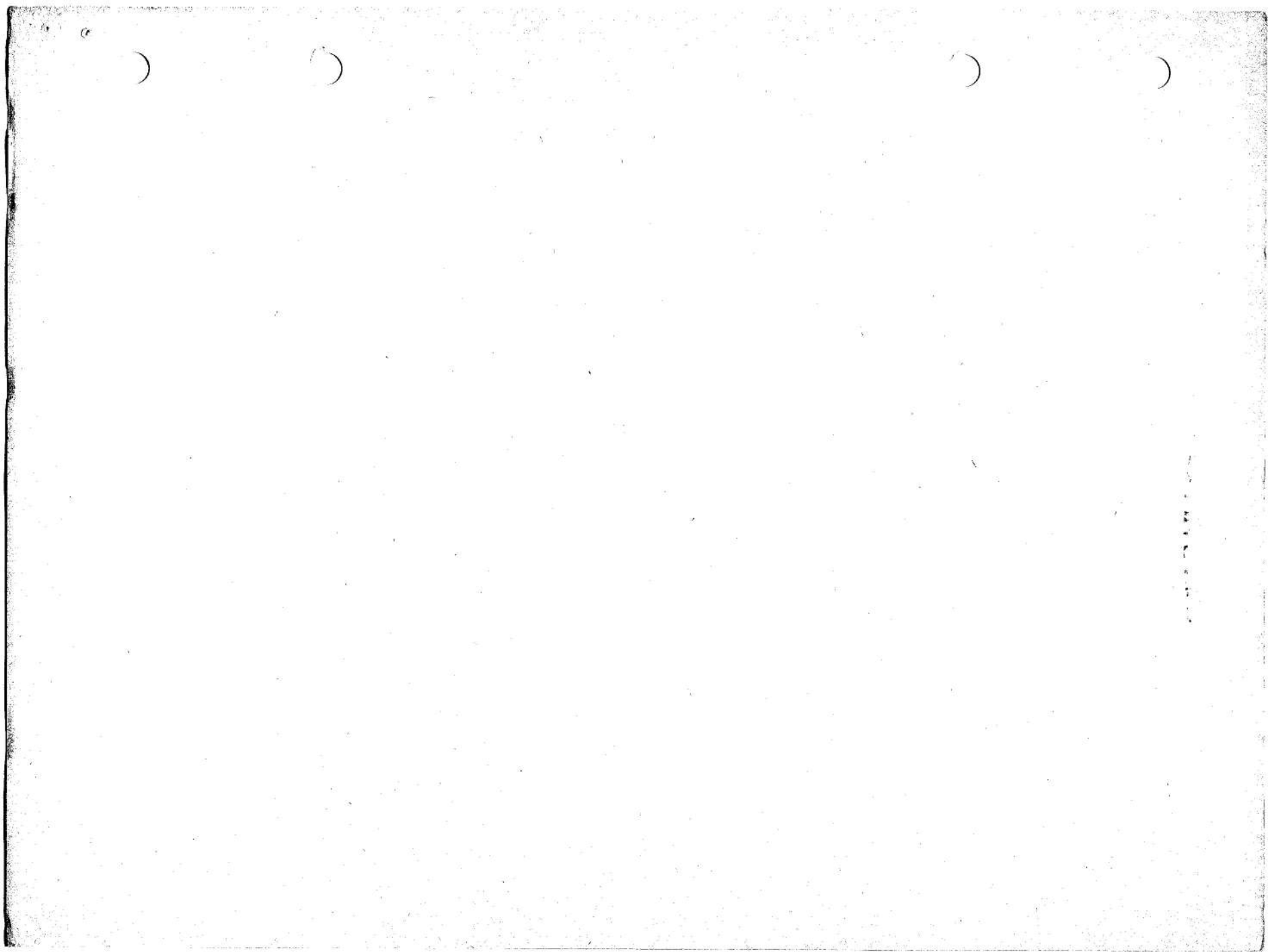

This file was downloaded
from the RTFM Library.

Link: www.scottbouch.com/rtfm

Please see site for usage terms,
and more aircraft documents.



LIGHTNING MK. 1
COVER PITOT HEAD
EB2-88-511