

Do not destroy

Chapter 34

PUMP MB.022 Mk. 6, 7, 35 AND 39

LIST OF CONTENTS

	Para.		Para.
Introduction	1	Commutator	16
Special tools	2	To fit flexible leads to the field coil ...	17
Dismantling	3	Assembling	18
Separation of the pump from the motor	4	To assemble the pump	19
To dismantle the pump Mk. 6 & 7 units	5	To assemble the motor	20
To dismantle the pump Mk. 35 & 39	6	To assemble the pump to the motor ...	21
units	6	Testing	22
To dismantle the motor	7	Test equipment	23
Cleaning		Pump test	24
Pump	8	Motor test	29
Motor	9	Combined motor and pump test Mk. 6	32
Examination	10	Combined motor and pump test Mk. 7	36
Pump	11	Combined motor and pump test Mk. 35	40
Motor	12	Combined motor and pump test Mk. 39	44
Repair		Fault diagnosis	48
Replacement of bushes in pump body...	13	Preparation for despatch	49
Replacement of gland sleeve and ball		Preservation and storage	
bearing	14	Inhibiting	50
Carbon thrust washer	15	Storage	51

LIST OF TABLES

	Table
Special tools	1
Fault diagnosis	2
Schedule of fits, clearances and repair tolerances	3

LIST OF ILLUSTRATIONS

	Fig.		Fig.
General view of MB.022 pump	1	Exploded view of MB.022 pump	4
Fitting replacement bushes in pump body	2	Exploded view of motor	5
Fitting gland sleeve and ball bearing ...	3	Fits and clearances diagram	6

Introduction

1. The Plessey Type MB.022 (fig. 1) is an electrically driven booster pump used for priming and starting gas turbine engines. The unit is described in A.P.4343D, Vol. 1, Book 2, Sect. 7, Chap. 34.

Special tools

2. In addition to the normal workshop tools and equipment, the special tools listed in Table 1, or their equivalents, are required to recondition the unit.

RESTRICTED

RESTRICTED

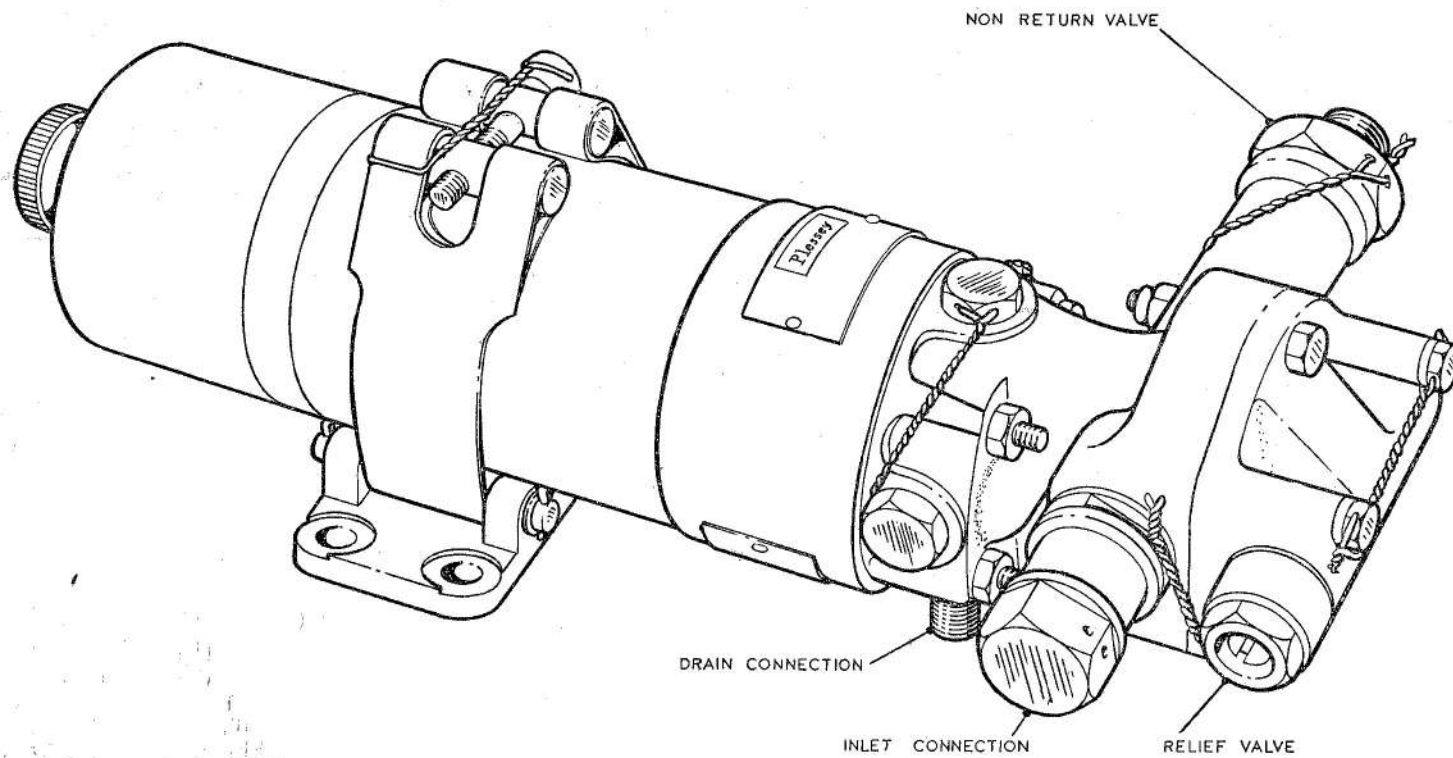

Fig. 1. General view of MB.022 pump

TABLE 1**Special tools**

Ref. No.	Nomenclature	Part No.	Fig. No.
—	Thimble	TA.3056	—
—	Tool for removing ball bearing	TV.8683	—
—	Tool for fitting replacement gland sleeve and ball bearing	TV.8682	5
—	Assembly fixture	TV.7081	—
—	Pin spanner	MA.1864 or T.309857	—
—	Clamping fixture	TV.6033	—
—	Service bolt (2 off)	T.100088	—

DISMANTLING

3. During dismantling, discard all sealing rings, gland seals, oil seals, gaskets, split pins, tabwashers, locking wire, and circlips of less than 1.000 in. diameter. All components should be kept together and reconditioned as one separate unit.

Separation of the pump from the motor

4. Remove the pump from the motor.

- (1) Remove the saddle bracket assembly.
- (2) Mount the unit in the assembly fixture TV.7081.
- (3) Remove the four 2 B.A. nuts and washers securing the pump to the motor and remove the pump from the motor.
- (4) Fit the service bolts, T.100088 to the pump unit.
- (5) Remove the motor from the fixture.

To dismantle the pump for Mk. 6 and 7 units

5. Dismantling of the pump is carried out as follows, refer to fig. 4:—

- (1) Remove the distance sleeve, then remove the service bolts and withdraw the drive shaft assembly.
- (2) Remove the split taper pin secur-

ing the drive shaft coupling, then withdraw the coupling and the bearing housing.

(3) Depress the thrust plate and remove the drive pin from the drive shaft, then allow the thrust plate, gland seal, gland plate and gland spring to eject under control.

(4) Remove the snap ring and collar securing the seal housing assembly, then withdraw the housing assembly.

(5) Remove the non-return valve assembly from the pump.

(6) Remove the unions and gaskets from the non-return valve body and withdraw the valve disc and spring.

(7) Remove the relief valve locknut, then unscrew the adjuster and screw.

(8) Withdraw the spring and the relief valve.

(9) Remove the retaining bolts, washers, nuts and the pump cover.

Note . . .

Ensure that the joint faces are not damaged during dismantling and that the two steel balls in the pump cover are not disturbed.

(10) Remove the pump gears and shafts together with the ball keys.

RESTRICTED

(11) Suitably mark the inner face of the driving gear and the driven gear to facilitate re-assembly.

(12) Remove the unions and plugs from the pump body.

To dismantle the pump for Mk. 35 and 39 units

6. Dismantling of the pump is carried out as follows, refer to fig. 4:—

(1) Remove the service bolts, then withdraw the gland assembly from the pump.

(2) Using circlip pliers, remove the circlip at the pump end of the gland assembly.

Caution . . .

The coupling shaft must be loaded to prevent the spring ejecting and damaging the gland seal components.

(3) Allow the spring to extend, then remove the thrust plate and the coupling shaft, together with the thrust washer assembly thrust collar, gland sleeve, spring, and support washer.

(4) Remove the circlip at the motor end of the gland housing and withdraw the seal backing washers, oil seal and distance piece.

(5) Remove the remaining pump details as previously described.

To dismantle the motor

7. Dismantling of the motor is carried out as follows, refer to fig. 5:—

(1) Remove the sleeve and the plug transportation cap from the motor body.

(2) Unlock and remove the two 4 BA screws, spring washers and sealing washers securing the clamp plate. Withdraw the clamp plate, sealing washers and the brush gear cover.

(3) Remove the four 6 BA screws and shakeproof washers, then remove the plug shell and the gasket.

(4) Disconnect the field coil leads from the plug moulding, then remove

the two 4 BA screws and the plug moulding.

(5) Remove the screws and spring washers securing the brush leads to the brush gear assembly. Identify and remove the brushes from the brush holders.

(6) Unlock and remove four 4 BA screws from the brushgear clamp plates.

(7) Secure the armature shaft against rotation and remove the countersunk screw, shakeproof washers and bearing washer retaining the commutator end ball bearing.

(8) Remove the two main screws and withdraw the brushgear assembly. Press the armature shaft out of the ball bearing. Separate the armature from the field coil assembly.

(9) Using a pin punch, remove the drive pin from the armature shaft.

(10) Secure the armature shaft against rotation, remove the staggings, then using pin spanner T.309857, remove the drive-end bearing ringnut.

(11) Press the armature shaft out of the drive-end bearing.

(12) Remove the staggings, then the three 4 BA screws securing the drive-end bearing washer and remove the washer from the drive-end plate.

(13) Remove the ball bearings from the drive-end plate and the commutator-end frame.

CLEANING

Pump

8. The pump end of the unit should be cleaned as follows:—

(1) Wipe the ball bearing external diameter with a clean cloth lightly dampened with white spirit (BSS.245).

(2) Wash the remaining components and flush oilways with clean kerosine, then dry with clean, dry, compressed air.

~~RESTRICTED~~

- (3) Degrease the components in trichlorethylene vapour.

Motor

9. The motor should be cleaned as follows:—

- (1) Clean all metal components with white spirit to remove all traces of grease and dirt.
- (2) Wash the ball bearings in clean white spirit, slowly rotating the inner or outer race to assist cleaning. Dry the bearing using clean, dry, compressed air.

Note . . .

The bearings should be soaked in white spirit, then swirled to dislodge any grease or dirt. Where bearings are particularly dirty, they may be cleaned using a suitably filtered pressure jet. It is advisable to avoid spinning the bearings, to avoid damage due to the absence of lubricant.

- (3) Clean the neoprene parts with a rag moistened with lead-free petrol.

EXAMINATION

10. Worn dimensions must be within the limits detailed in Table 3, and figures obtained from dimensional checks must be recorded so that clearance checks involving two or more parts can be ascertained. Detailed operations necessary to replace or repair individual parts follow the inspection procedure under separate headings.

Pump

11. Pump components should be examined as follows:—

- (1) Visually examine all parts, whether specifically mentioned or not, for cracks, scores, burrs, damage, corrosion and surface protection.
- (2) Examine the relief valve seating and guide bore for wear. If these are worn beyond the specified limit the cover must be rejected. Slight scoring on the cover face may be removed by rubbing down with fine emery cloth

on a surface plate using paraffin as a lubricant. The cover face must be kept perfectly flat.

- (3) Examine the valve plate and seating of the non-return valve; lap as necessary.

(4) Examine the pump body and bronze bushes for wear and damage; light bedding marks in the gear chamber are acceptable, but worn or damaged bushes should be replaced as described in para. 13.

(5) Examine the gears for damage on the faces of the teeth and indentation on the keyways caused by the ball keys; either of these faults will entail rejection.

(6) Examine the gear shafts and ball keys for damage; light damage to the shaft may be eased, but damage or flats on the steel balls will entail their rejection.

Sub-para. (7), (8) and (9) are applicable to Mk. 6 and 7 only

(7) Examine the seal face of the carbon thrust washer for cracking, chipping and scoring. Cracking or chipping will entail rejection of the seal housing, but light scoring may be removed by lapping on a surface plate using jeweller's rouge and paraffin.

(8) Examine the gland sleeve for security; loose sleeves may be rectified, or replacement sleeves fitted, as described in para. 14.

(9) Check the driveshaft bearing end float; if beyond limits, remove the bearing using tool, TV.8683. Fit a new bearing as described in para. 14.

Sub-para. (10) and (11) are applicable to Mk. 35 and 39 only.

(10) Examine the carbon thrust washer, thrust plate and the mating faces on the flange of the coupling shaft for scoring; light scoring may be removed by lapping with jeweller's rouge and paraffin.

(11) Examine the carbon thrust

~~RESTRICTED~~

washer for chipping and damage; either of these faults will entail rejection.

Motor

12. Motor components should be examined as follows:—

- (1) Examine the brushes and brush springs for damage and wear.
- (2) Inspect ball bearings for wear, pitting, corrosion and damage; any of these faults will entail rejection. Lubricate the bearings as described in para. 20.
- (3) Inspect armature for security of segments, cable ends in commutator segment slots, cable binding and completeness of varnish protection.
- (4) Examine commutator for pitting and wear; the commutator may be rectified as described in para. 16.
- (5) Check the armature windings for insulation and resistance. Reject if insulation is less than 10 Megohms at 250V d.c. or the resistance between any two opposite commutator segments is less than 0.125 ohm.

(6) Inspect the field windings for signs of overheating, completeness of varnishing and security of flexible extension leads.

(7) Measure the resistance of the field windings which must not be less than 10 Megohms using a 250V insulation resistance tester, Type C, Ref. No. 5G/152.

(8) Inspect all insulating sleeves for damage and renew as necessary.

REPAIR

Replacement of bushes in pump body

13. (1) Carefully machine out the worn or damaged bushes in the pump body.
(2) Insert the new bronze bushes into bores of the pump body as shown in fig. 2. Ensure that the ends of the bushes are 0.005 to 0.020 in. below the pump body face. Lightly ream the bushes 0.2500 to 0.2505 in. diameter.

Replacement of gland sleeve and ball bearing

14. (1) Place the gland sleeve, tongues downwards, on the tool base plate TV.8682 as shown in fig. 3.

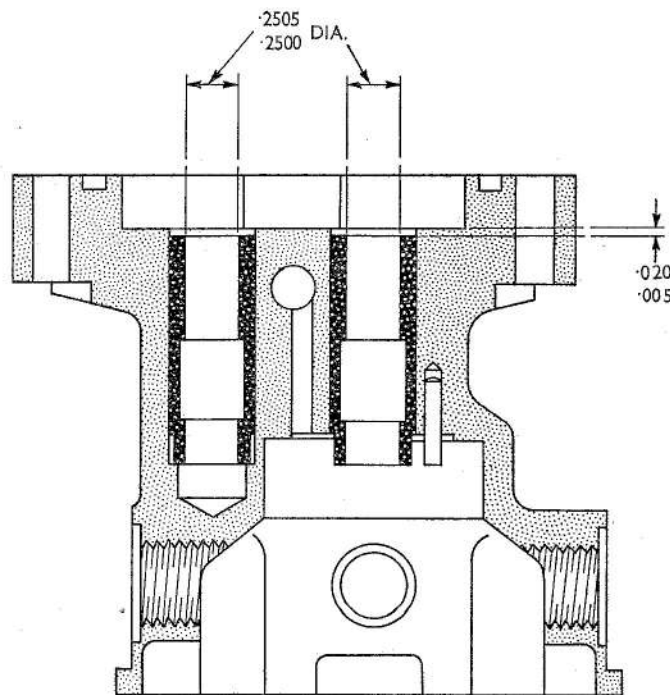

Fig. 2. Fitting replacement bushes in pump body

~~RESTRICTED~~

(2) Assemble the driveshaft, bearing diameter uppermost, to the sleeve, interposing the sealing washer.

(3) Position the spring loaded swaging adaptor over the driveshaft then with a suitable bench press, carefully swage the sleeve upper end over driveshaft flange.

(4) Remove the driveshaft assembly from the fixture and check the sleeve for security, cracking and damage. Ensure that the sealing washer is properly located.

(5) Mount the driveshaft assembly on the base plate, position the ball bearing over the driveshaft, then, using the adaptor and a suitable bench press, press the bearing on to the shaft. Check that the bearing is pressed fully home.

Carbon thrust washer

15. To fit new carbon thrust washer

(1) Carefully machine out the carbon washer in the housing ensuring that no material is removed from the housing.

(2) Thoroughly clean and degrease the mating faces of the carbon thrust washer and the housing. Slightly roughen the mating faces.

(3) The carbon thrust washer is affixed to the housing by cold setting araldite. The mixture must be accu-

rately proportioned by weight as follows:

Araldite casting resin D	10 parts
Hardener 951	1 part

(4) Thoroughly mix until homogeneous, then apply the mixture lightly and evenly to the mating faces.

Note . . .

The mixture has a useful life of 1½ hours at room temperature and, once reaction has started, thinners cannot be used to prolong the process.

(5) Bring both parts together, ensuring that the carbon washer is concentric with the housing bore. Apply a pressure of 5 to 9 lb while the araldite is setting.

(6) Place the housing in an oven, maintained at 60 to 65°C. (140 to 149°F.), for one hour.

(7) Remove the housing from the oven and allow to age, at room temperature for 48 hours.

(8) Lap the carbon thrust washer as previously described in para. 11, sub-para. (7) and (10).

Commutator

16. A worn, burnt or pitted commutator may be rectified as follows:—

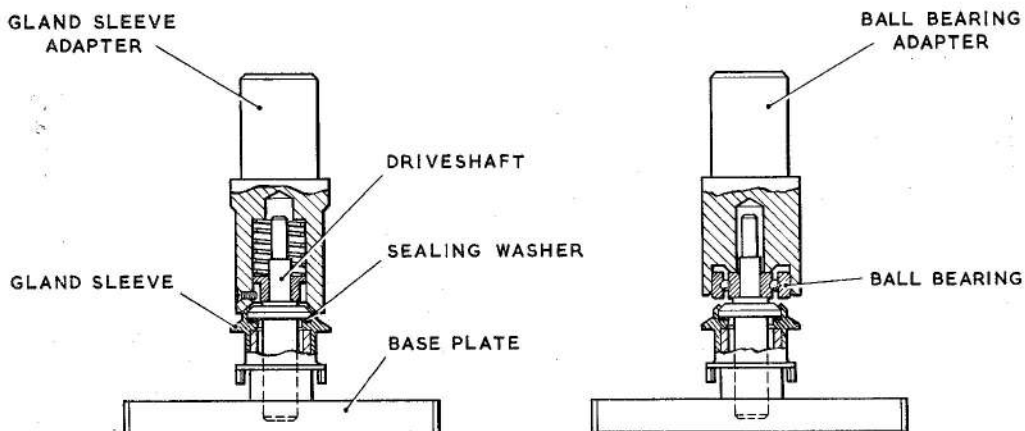

Fig. 3. Fitting gland sleeve and ball bearing

RESTRICTED

(1) Skim the commutator using the machine described in A.P.4343S, Vol. 1, Book 2, Sect. 13, Chap. 11. Undercut the mica insulation to a maximum depth of 0.020 in.; remove burrs and ensure that no mica is left adjacent to the commutator surface. Check that the commutator diameter is within the limits given in the Fits and Clearances Schedule, Table 3.

To fit flexible leads to the field coil

17. To replace the flexible leads to the field coil follow the procedure given below:—

(1) Materials required

- (a) 2 mm Vidaflex 555 glass braided sleeving, fully varnished.
- (b) 4 mm Vidaflex 555 glass braided sleeving, fully varnished.
- (c) 23/36 T.C.U. Flex varnished, double glass lapped and braided, T.D.F.360 (Lewcos Ltd., 24, Queen Anne's Gate, London S.W.1).
- (d) Synthetic rubber tube PS/M/3068 1/16 in. i/d.
- (e) Resin cored solder Ref. No. 30B/1606—(D.T.D.599).
- (f) Varnish, Bergers 'HYMEG' AD2.

(2) Cut four lengths of 23/36 flex, one at 3.5 in., two at 2.25 in., and one at 2 in. Remove $\frac{3}{8}$ in. of insulation from both ends of each lead and tin the bared wire using item 17(1)(e).

Note . . .

With the commutator end frame locating pin positioned at top dead centre, the 3.5 in. lead is attached to the top left field coil loop and the 2 in. lead is attached to the bottom right loop when viewed on the commutator end of the assembly.

- (3) Clean and tin each field coil loop.
- (4) Select a lead and pass the bared end of the lead through its respective field coil loop and firmly close the end

of the lead into the loop. Solder with item 17(1)(e), cut off excess wire and apply varnish item 17(1)(f).

(5) Cut a piece of 2 mm Vidaflex 555 to the required length and slide it over the lead.

(6) Cut a $\frac{3}{4}$ in. length of 4 mm Vidaflex 555, slide it over the lead and position over the soldered connection.

(7) Cut a 1 in. length of rubber sleeve, item 17(1)(d), and slide it over the lead.

(8) Crimp the tag to the lead and solder using item 17(1)(e), apply varnish item 17(1)(f), slide the rubber sleeve over the soldered connection.

ASSEMBLING

18. The importance of cleanliness cannot be over emphasized, therefore, all work must be effected in a dust free atmosphere. All tools and equipment must be kept in a clean and serviceable condition. Items listed in para. 3, if during assembling are fitted and then removed should be discarded.

To assemble the pump

19. Assemble the pump as follows:—

- (1) Assemble the relief valve, spring, adjusting screw, adjuster and the locknut to the pump cover.
- (2) Assemble the drive and driven driven gears to their respective shafts together with the ball keys, using light grease or vaseline to retain the ball keys.

Note . . .

The gears should be assembled as indicated by the markings made during dismantling.

(3) Place the pump body in the assembly fixture TV.6033, lightly lubricate the bore of each bush and the gear pockets, with oil OMD.270 (Ref. No. 34A/9109584), then assemble the gears and shafts to their respective positions.

(4) Check that the thrust balls in the pump cover are correctly pressed into position and that the faces of both

RESTRICTED

gears are underflush with the body joint face.

(5) Fit the sealing ring to the pump body, then fit the pump cover aligning the relief valve duct, and secure with the 2 BA bolts, washers and nuts; fully tighten the bolts evenly in diametrically opposed sequence.

(6) Check the assembly for freedom of rotation. If freedom is restricted, remove the pump cover and recheck clearances.

(7) *Mk. 6, 35 and 39 only.* Fit the gasket and the inlet union to the non-return valve body, then assemble the valve plate and spring, followed by the gasket and outlet union.

(8) Fit the non-return valve to the delivery side of the pump, then fit the remaining unions, plugs and sealing washers as shown on fig. 2.

(9) *Mk. 6 and 7 only.* Fit the sealing ring to the seal housing, then assemble the housing over the dowel pin to the body with the carbon thrust washer uppermost. Fit the seal housing collar and secure the assembly with the snap ring.

(10) Assemble the gland spring, gland plate, gland seal and thrust plate to the gland sleeve, taking care to avoid nipping the gland seal between the thrust plate and the periphery of the gland sleeve. Compress the spring and insert the drive pin into the drive shaft.

(11) Fit the drive shaft to the bearing housing, locating the ball bearing in the housing recess.

(12) Fit the coupling and secure it with the split taper pin.

(13) Fit the drive shaft assembly to the pump, interposing the gasket, and secure with the service bolts T.100088. Submit the pump to the tests detailed in para. 22 onwards.

(14) *Mk. 35 and 39.* Assemble the distance piece, oil seal, sealing lip first, and the seal backing washer to the motor end of the gland housing and secure with the circlip.

(15) Position the sealing ring at the inner end of the counterbore at the pump end of the gland housing, then insert the spring support washer.

(16) Fit the sealing ring to the gland sleeve, position the thrust collar and the spring on the sleeve, then locate the assembly, spring first, in the gland housing.

(17) Fit the drive pin to the coupling shaft, then position thimble TA.3056 over the motor end of the shaft. Assemble the thrust washer assembly and the shaft to the gland housing.

(18) Position the thrust plate over the coupling shaft flange, apply sufficient pressure to compress the spring and secure the assembly with the circlip.

(19) Fit the sealing ring to the drive coupling, then fit the coupling to the pump body, engaging the pump drive shaft.

(20) Fit the sealing ring to the gland housing, then assemble the housing to the pump body, interposing the gasket and aligning the coupling shaft. Fit the service bolts T.100088 and secure the gland assembly. Submit the pump to the tests detailed in para. 22 onwards.

To assemble the motor

20. Assemble the motor as follows:—

(1) Lightly lubricate the ball bearings with grease XG-277.

(2) Fit the drive end bearing to the drive end plate, and press fully home.

(3) Fit the drive end bearing washer and secure with 4 BA countersunk screws. Lock the screws by centre popping at both ends of the screwdriver slots.

(4) Fit the drive end of the armature shaft into the bearing and secure with the bearing nut. Using pin spanner T.309857, fully tighten the nut, then lock the nut by centre popping the thread in two places.

(5) Assemble the armature and drive end plate to the field coil and magnet assembly, aligning the locating pin.

RESTRICTED

RESTRICTED

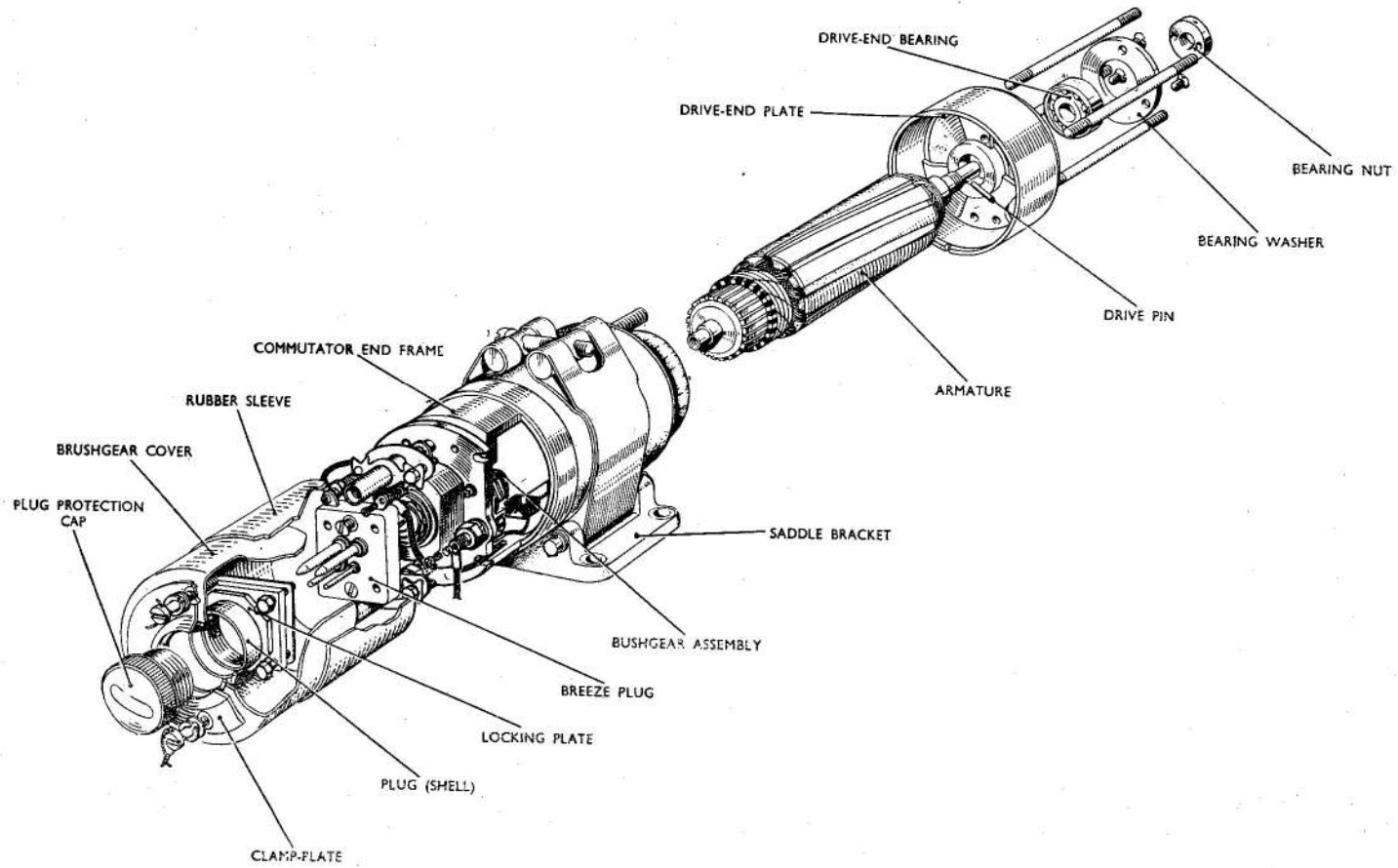

Fig. 5. Exploded view of motor

(6) Fit the brushgear assembly to the commutator-end frame, then fit the brushgear clamp plates and secure with 6 BA screws and lockplates.

(7) Insert the brushes into the brush boxes and secure the tags to the brush box with 6 BA spring washers and screws. Using suitable equipment, measure the spring pressure which must be within 6 to 7 oz.; adjust the spring pressure, as necessary, by rotating the brush holder pin. Remove the brushes from the boxes.

(8) Assemble the commutator-end frame to the field coil and magnet assembly, threading the flexible leads through the apertures and aligning the locating pin.

(9) Fit the commutator-end ball bearing to the armature shaft and press fully home. Fit the bearing washer and secure with the shakeproof washer and screw.

(10) Refit the brushes to the brush boxes.

(11) Position the assembly with the commutator-end frame locating pin bottom dead centre.

(12) Fit the plug moulding to the commutator-end frame with the terminal tags uppermost and secure with 4 BA screws. Seal the screw heads, flush to the plug moulding surface, with De Khotinsky or Claude Campbell W.E.2 wax.

(13) Connect the longest lead to the right hand plug moulding tag and the shortest lead to the left hand tag, viewed on the commutator-end. Secure the leads with 8 BA screws, spring washers and nuts.

(14) Connect the remaining leads to the adjacent terminals on the brushgear assembly and secure with 6 BA screws and double spring washers.

(15) Fit the plug shell, together with the gasket, and secure with 6 BA screws.

(16) Submit the motor to the tests detailed in para. 29-31.

(17) Fit the gasket ring over the plug shell, then fit the brushgear cover, aligning the holes with the main screws.

(18) Fit the gasket ring over the plug shell, then fit the clamp plate, together with the sealing washers, and secure with the screws, plain and spring washers. Wirelock the clamp plate screws together.

(19) Fit the neoprene sleeve and position it over the brushgear cover, commutator-end frame and the field coil and magnet assembly.

(20) Fit the transportation cap to the terminal plug.

To assemble the pump to the motor

21. Assemble the pump to the motor as follows:—

(1) Fit the drive pin to the armature shaft.

(2) Mount the motor in the assembly fixture, TV.7081, with the motor spindle uppermost.

(3) *Mk. 6 and 7.* Remove the service bolts and withdraw the drive shaft assembly from the pump.

(4) Position the distance sleeve on the motor, then assemble the drive shaft assembly, over the studs, engaging the coupling.

(5) Assemble the pump to the drive shaft assembly, interposing the gasket and engaging the driving shaft, then secure with 2 BA nuts and washers. Submit the combined pump and motor to the test detailed in para. 32-39.

(6) *Mk. 35 and 39.* Remove the service bolts, then assemble the pump to the motor, engaging the coupling shaft, and secure with 2 BA nuts and washers. Submit the combined pump and motor to the test detailed in para. 40-47.

TESTING

22. If the pump does not conform to the schedule requirements, reference should be made to Table 2.

~~RESTRICTED~~

Test equipment

23. The equipment used to test the combined motor and pump is described in A.P.4343S, Vol. 1, Book 2, Sect. 10, Chap. 1. A suitable motor is required when testing the pump unit only.

Test fluid: AVTUR 50 (D.Eng.R.D.2494)
A suitable test rig is required when testing the motor unit only.

Pump test

Gland pressure test (Mk. 35 and 39)

24. With the pump immersed in kerosine, apply an air pressure of 5 lb/in² to the drain connection and check for leaks; no leakage is permissible.

Running in

25. Run the pump at 3,450 rev/min and adjust the relief valve to give a delivery pressure of 150 lb/in² at zero flow. Adjust the rig control valve to obtain a delivery pressure of 100 lb/in², then run the pump for 30 minutes.

Pressure test

26. Run the pump for 5 minutes at 3,450 rev/min, adjusting the rig control valve to obtain a delivery pressure of 120 to 130 lb/in² and check for leakage at the gland drain; no measurable leakage is permitted.

Relief valve setting

27. Run the pump at 3,450 rev/min, then adjust the relief valve to give a delivery pressure of 130 to 150 lb/in² at zero flow. Record the delivery pressure.

Priming check

28. Run the pump at 3,450 rev/min, adjusting the rig control valve to obtain a delivery pressure of 100 lb/in². Open the pump inlet pipe to atmosphere and allow the pump to run for 30 sec. circulating air, then close the inlet pipe. Check the time taken for the pump to reprime which must not exceed 8 sec.

Motor test*Insulation and resistance check*

29. (1) With the brushes raised, measure the resistance between the two main terminals which must be within 72 to 88 ohms at 15°C. (58°F.).

(2) With the brushes raised, measure the resistance between each brush holder and the main terminal to which it is connected. This must be within 0.037 and 0.045 ohms at 15°C. (59°F.).

(3) With the brushes raised, measure the resistance between two diametrically opposed commutator segments which must be within 0.125 and 0.155 ohms at 15°C. (59°F.).

(4) Measure the insulation resistance between the main terminals and the frame which must not be less than 0.5 Megohms at 500V d.c.

Running in

30. Run the motor at 10,000 rev/min until the brushes are bedded over the complete arc and at least 80 per cent of their area. Check that the armature rotates in a counter-clockwise direction when viewed from the drive end of the motor.

Performance test

31. (1) With a 24V d.c. supply, run the motor for 10 minutes against no load. Record the motor speed and the current consumption. The motor speed must be within 16,000 and 25,000 rev/min and the current consumption must not exceed 4A. There must be no excessive vibration or noise and the sparking at the brushes must not be greater than a continuous blue pin point spark.

(2) Allow the motor to cool for 30 minutes, then fit the brushgear cover as detailed in para. 20(17) and (18).

(3) With an 18V d.c. supply, run the motor for one minute against a torque of 45 oz in. Record the motor speed and the current consumption. The motor speed must not be less than 5,000 rev/min and the current consumption must not exceed 25A.

(4) Allow the motor to cool for 30 minutes, then with a 24V d.c. supply, run the motor for one minute against a torque of 50 oz in. Record the motor speed and the current consumption. The motor speed must not be less than 8,000 rev/min and the current consumption must not exceed 27.5A.

RESTRICTED

(5) Allow the motor to cool for 30 minutes, then with a 29V d.c. supply, run the motor for 15 minutes against a torque of 13.3 oz in. Record the motor speed, current consumption and the temperature rise at the field coil and magnet assembly. The motor speed must not be less than 13,000 rev/min, the current consumption must not exceed 11A and the temperature rise must not exceed 50°C. (122°F.).

(6) With the motor still warm from the previous test, check the insulation resistance between the main terminals and the frame which must not be less than 0.5 Megohm at 500V d.c.

Combined motor and pump test (Mk. 6)

Relief valve setting

32. (1) Remove the non-return valve.

(2) With an electrical supply of 24V and an inlet pressure of 20 to 21 lb/in², adjust the relief valve and the rig control valve to obtain a delivery flow of 60 to 70 gal/hr at a delivery pressure of 125 to 130 lb/in². Record the delivery flow and pressure.

(3) Using the rig control valve, reduce the delivery flow to zero and check that the delivery pressure does not exceed 150 lb/in². Record the delivery pressure.

Performance test

33. (1) With an electrical supply of 24V and an inlet pressure of 20 to 21 lb/in², adjust the rig control valve to give a delivery flow of 90 gal/hr. Record the delivery pressure which must not be less than 100 lb/in².

(2) Increase the electrical supply to 29V and adjust the rig control valve to give 90 gal/hr. Record the delivery pressure which must not be less than 100 lb/in².

(3) Reduce the electrical supply to 18V and adjust the rig control valve to give a delivery flow of 90 gal/hr. Record the delivery pressure which must not be less than 80 lb/in².

(4) Refit the non-return valve.

(5) Increase the electrical supply to

24V. With an inlet pressure of 20 to 21 lb/in², adjust the relief valve and the rig control valve to obtain a delivery flow of 18 to 23 gal/hr at a delivery pressure of 125 lb/in². Record the delivery flow and pressure.

Priming check

34. (1) With an electrical supply of 24V, adjust the rig control valve to give a delivery pressure of 100 lb/in².

(2) Open the pump inlet pipe to atmosphere and allow the pump to run for 30 sec., circulating air, then close the inlet pipe. Record the time taken for the pump to reprime which must not exceed 8 sec.

Proof test

35. (1) With an electrical supply of 24V and an inlet pressure of 20 to 21 lb/in², adjust the rig control valve to give a delivery pressure of 125 lb/in².

(2) Run the pump for one minute then cut off the electrical supply. Record the current consumption which must not exceed 25A.

(3) Wait 10 to 12 minutes then repeat the test detailed in (2).

Note . . .

The inlet pressure must be maintained during the stationary period.

(4) Repeat the test detailed in (3), then measure and record the insulation resistance between the main terminals and the frame which must not be less than 0.5 Megohm at 500V d.c.

Note . . .

No leakage is permissible, except at the gland drain and this must not exceed 5 ccs. during tests (2), (3) and (4).

Combined motor and pump test (Mk. 7)

Relief valve setting

36. (1) With an electrical supply of 24V, adjust the relief valve to give a delivery pressure of 130 to 150 lb/in² at zero flow.

(2) Adjust the rig control valve to

RESTRICTED

obtain a delivery pressure of 100 lb/in². Record the delivery flow which must not be less than 100 gal/hr.

Performance test

37. (1) Increase the electrical supply to 29V. Record the delivery flow and pressure.
- (2) Reduce the electrical supply to 18V. Record the delivery flow and pressure. The delivery pressure must be not less than 60 lb/in².

Priming check

38. (1) Increase the electrical supply of 24V and adjust the rig control valve to give a delivery pressure of 100 lb/in².
- (2) Open the pump inlet pipe to atmosphere and allow the pump to run for 30 sec., circulating air, then close the inlet pipe. Record the time taken for the pump to reprime which must not exceed 8 sec.

Proof test

39. (1) With an electrical supply of 24V and an inlet pressure of 20 to 21 lb/in², adjust the rig control valve to give a delivery pressure of 120 lb/in².
- (2) Run the pump for one minute then cut off the electrical supply. Record the current consumption which must not exceed 25A.
- (3) Wait 10 to 14 minutes then repeat the test detailed in (2).

Note . . .

The inlet pressure must be maintained during the stationary period.

- (4) Repeat the test detailed in (3), then measure and record the insulation resistance between the main terminals and the frame which must not be less than 0.5 Megohms at 500V d.c.

Note . . .

No leakage is permissible, except at the gland drain and this must not exceed 5 ccs during tests (2), (3) and (4).

Combined motor and pump test (Mk. 35)

Relief valve setting

40. (1) With an electrical supply of 24V, adjust the relief valve to give a delivery pressure of 115 to 120 lb/in² at zero flow.
- (2) Adjust the rig control valve to obtain a delivery pressure of 85 lb/in². Record the delivery flow which must not be less than 100 gal/hr.

Performance test

41. (1) Increase the electrical supply to 29V. Record the delivery flow and pressure.
- (2) Reduce the electrical supply to 18V. Record the delivery flow and pressure which must not be less than 60 gal/hr and 50 lb/in² respectively.

Priming check

42. (1) Increase the electrical supply of 24V and adjust the rig control valve to give a delivery pressure of 85 lb/in².
- (2) Open the inlet pipe to atmosphere and allow the pump to run for 30 sec., circulating air, then close the inlet pipe. Record the time taken for the pump to reprime which must not exceed 8 sec.

Proof test

43. (1) With an electrical supply of 24V and an inlet pressure of 15 to 16 lb/in², adjust the rig control valve to give a delivery pressure of 100 lb/in².
- (2) Run the pump for one minute then cut off the electrical supply. Record the current consumption which must not exceed 25A.
- (3) Wait 10 to 14 minutes then repeat the test detailed in (2).

Note . . .

The inlet pressure must be maintained during the stationary period.

- (4) Repeat the test detailed in (3), then measure and record the insulation resistance between the main terminals and the frame which must not be less than 0.5 Megohm at 500V d.c.

RESTRICTED

Note . . .

No leakage is permissible, except at the gland drain and this must not exceed 5 ccs during tests (2), (3) and (4).

Combined motor and pump test (Mk. 39)

Relief valve setting

44. (1) With an electrical supply of 24V and an inlet pressure between 15 and 16 lb/in², adjust the relief valve to give a delivery pressure of 68 to 73 lb/in² at zero flow.

(2) Adjust the rig control valve to obtain a delivery pressure of 40 lb/in². Record the delivery flow which must not be less than 120 gal/hr.

Performance test

45. (1) Increase the electrical supply to 29V and an inlet pressure of 15 to 16 lb/in², run the pump and record the delivery flow and pressure.

(2) Reduce the electrical supply to 18V and adjust the rig control valve to give a delivery pressure of 40 lb/in². Record the delivery flow which must not be less than 90 gal/hr.

Priming check

46. (1) Increase the electrical supply to 24V and adjust the rig control valve to give a delivery pressure of 40 lb/in².

(2) Open the pump inlet pipe to atmosphere and allow the pump to run for 30 sec., circulating air, then close the inlet pipe. Record the time taken

to reprime which must not exceed 8 sec.

Proof test

47. (1) With an electrical supply of 24V and an inlet pressure of 15 to 16 lb/in², adjust the rig control valve to give a delivery pressure of 40 lb/in².

(2) Run the pump for one minute then switch off the electrical supply. Record the current consumption which must not exceed 18A.

(3) Wait 10 to 14 minutes then repeat the test detailed in (2).

Note . . .

The inlet pressure must be maintained during the stationary period.

(4) Repeat the test detailed in (3) then measure and record the insulation resistance between the main terminals and the frame which must not be less than 0.5 Megohms at 500V d.c.

Note . . .

No leakage is permissible, except at the gland drain and this must not exceed 5 ccs during tests (2), (3) and (4).

Fault diagnosis

48. The following table indicates possible faults and their remedies. No account has been taken of incorrect assembly or obvious defects such as leaks, faulty rig connections etc.

TABLE 2

Fault diagnosis

Defect	Possible cause	Remedy
Excessive gland leakage	Poor sealing on gland faces	Lap carbon washer and thrust plate
Low delivery flow	Relief valve stuck open	Dismantle relief valve, clean and re-assemble
Delivery pressure unobtainable	Defective relief valve spring	Dismantle relief valve and check spring

~~RESTRICTED~~

Preparation for despatch

49. Using 22 s.w.g. stainless steel wire (D.T.D.189) wirelock the pump details as follows:

- (1) Pump body blanking plugs and drain connection to each other.
- (2) Outlet union or non-return valve to relief valve body retaining screw.
- (3) Relief valve body retaining screws in pairs.
- (4) Relief valve locknut to inlet union.
- (5) Saddle bracket screw to bracket.

PRESERVATION AND STORAGE**Inhibiting**

50. (1) Drain the pump completely of fuel.
- (2) Slowly rotate the pump while in-

roducing oil OX.275 (DEF.2181A) for a sufficient time to ensure that all internal surfaces are coated with oil. Drain off excess oil.

(3) Fit the transportation covers to the inlet, outlet and drain connections and to the motor electrical connection.

(4) Coat all external surfaces with a thin film of protective PX.1, Ref. No. 34B/9100478.

Storage

51. Place the pump in a polythene bag, then heat seal and pack in a strong cardboard or wooden box. Store in a cool, dry place away from injurious fumes for a period not exceeding three years.

Note . . .

If the pump is not used, it must be dismantled for examination and replacement of seals at the end of the three year period.

~~RESTRICTED~~

RESTRICTED

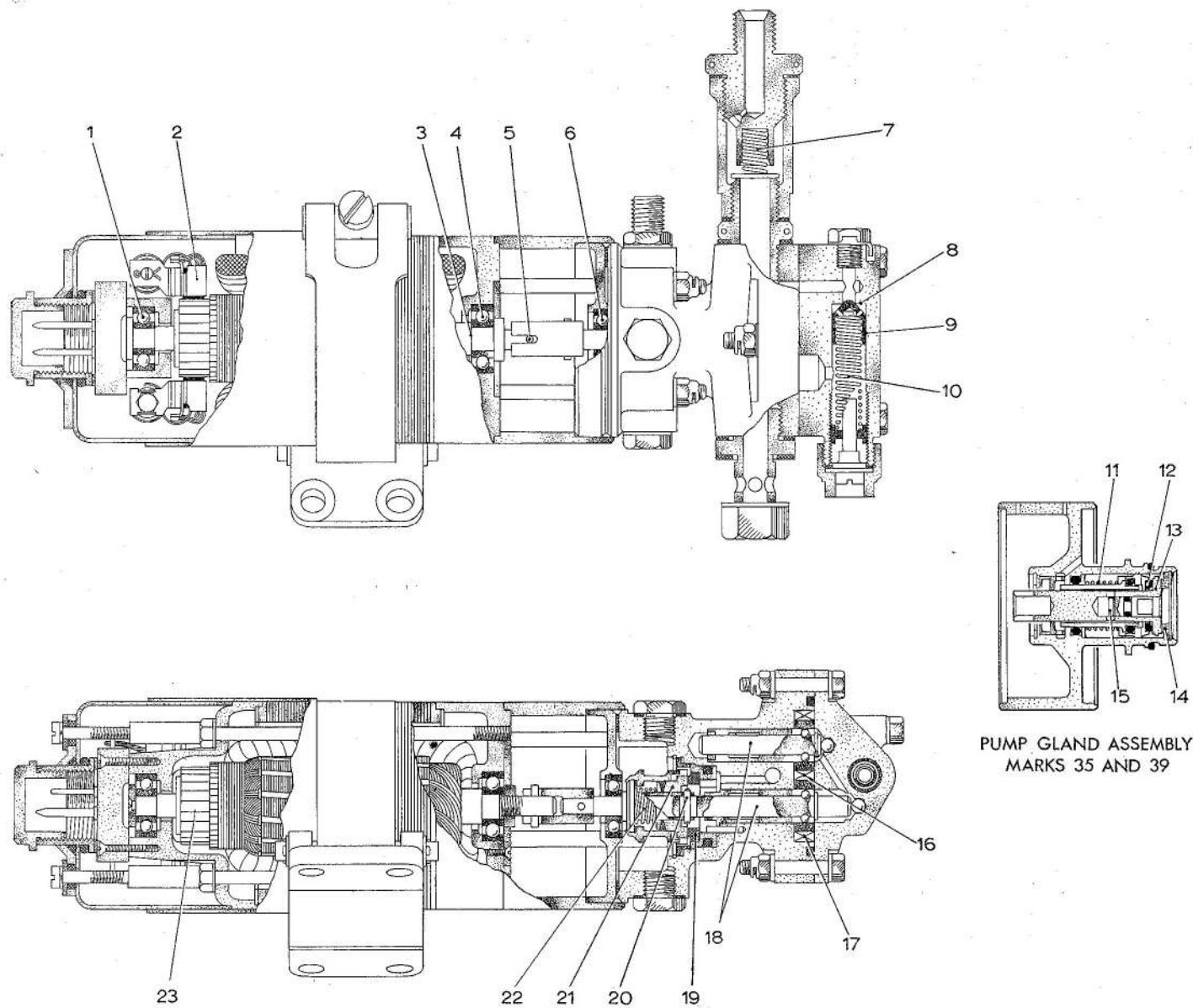

PUMP GLAND ASSEMBLY
MARKS 35 AND 39

Fig. 6. Fits and clearances diagram

TABLE 3
Schedule of Fits, Clearances and Repair Tolerances

Item No.	Part or description	Dimension	Dimension new	Permissible worn dimension	Clearance new	Permissible worn clearance	Remarks
1	COMMUTATOR-END HOUSING/ BEARING/ARMATURE SHAFT						
	Housing	Bore	0-7478			Intf. 0-0002	
			0-7483				
	Bearing	Dia.	0-7480			0-0006 Clear	
			0-7477				
	Bearing	Bore	0-2359			Intf. 0-0006	
			0-2362				
	Shaft	Dia.	0-2358			0-0004 Clear	
			0-2365				
2	MOTOR BRUSHES Brush	Length	0-3750	0-2500			
3	ARMATURE Armature	End float		0-0120			
4	DRIVE-END HOUSING/BEARING/ ARMATURE SHAFT						
	Housing	Bore	0-8659			Intf. 0-0002	
			0-8664				
	Bearing	Dia.	0-8658			0-0006 Clear	
			0-8661				

RESTRICTED

TABLE 3—(contd.)

Item No.	Part or description		Dimension new	Permissible worn dimension	Clearance new	Permissible worn clearance	Remarks
4 cont.	Bearing	Bore	0-3146			Intf. 0-0005	
			0-3150				
	Shaft	Dia.	0-3146			0-0004 Clear	
			0-3151				
5	COUPLING/DRIVE PIN						
	Coupling	Slot width	0-1148	0-1280		0-0203	0-0340
			0-1188				
	Pin	Dia.	0-0940	0-0865		0-0248	
			0-0945				
6	BEARING HOUSING/BEARING/DRIVE SHAFT						
	Housing	Bore	0-7469			Intf. 0-0011	
			0-7475				
	Bearing	Dia.	0-7480			0-0002	
			0-7477				
	Bearing	End float	0-2359	0-0060			
	Bearing	Bore	0-2362	0-2362		Intf. 0-0008	
			0-2362				
	Shaft	Dia.	0-2362			0-0000	
			0-2367				
7	NON-RETURN VALVE SPRING						
		Test length	0-6230				
		Test load	2 to 3 oz.	2 oz.			

RESTRICTED

TABLE 3—(contd.)

Item No.	Part or description	Dimension new	Permissible worn dimension	Clearance new	Permissible worn clearance	Remarks	
8	RELIEF VALVE BODY		2.0550			Measured from relief valve bore end face	
		Depth to seat	2.0850	2.1000			
9	RELIEF VALVE IN VALVE BODY		0.4370				
		Valve	Dia.	0.4375	0.4350		0.0015
							0.0030
		Body	Bore	0.4390	0.4415		
0.4400							
10	RELIEF VALVE SPRING	Test length	1.3750				
		Test load	2½ to 3 lb.	2½ lb.			
11	GLAND SPRING	Test length	0.4460				
		Test load	4½ to 5 lb.	4.25 lb.			
12	THRUST WASHER ASSEMBLY		0.355			Measured over housing and thrust washer	
		Length	0.3600	0.3450			
13	COUPLING SHAFT		0.1018				
		Shaft flange	Thickness	0.1030	0.1000		

RESTRICTED

TABLE 3—(contd.)

Item No.	Part or description	Dimension new	Permissible worn dimension	Clearance new	Permissible worn clearance	Remarks	
14	THRUST PLATE		0.0910				
		Length	0.0930	0.0900			
15	PUMP DRIVING SHAFT/DRIVE COUPLING/DRIVE PIN/COUPLING SHAFT		0.0985		0.0035		
		Shaft	Slot width	0.0995	0.1065	0.0065	
				0.0930			
		Drive coupling	Blade thickness	0.0950	0.0900	0.0040	
				0.0990		0.0090	
		Drive coupling	Slot width	0.1030	0.1070		
				0.0940		0.0004	
		Pin (shank)	Dia.	0.0950	0.0940	0.0012	
				0.1243			
		Pin (head)	Dia.	0.1246	0.1243		
		0.1250					
	Shaft (pin bore)	Bore	0.1255	0.1255			
16	GEARS		0.0730		0.0050		
			Chordal tooth thickness	0.0720	0.0110	0.0130	
			Backlash	—	—		

RESTRICTED

TABLE 3—(contd.)

Item No.	Part or description	Dimension new	Permissible worn dimension	Clearance new	Permissible worn clearance	Remarks
17	GEARS IN PUMP BODY					
	Gear	Dia.	0.8497	0.8487	0.0013	0.0023
			0.8500			
	Body	Dia. of gear pocket	0.8510	0.8520	0.0005	
			0.8505			
	Gear	Width	0.2465	0.2460	0.0015	0.0025
			0.2467		0.0003	
	Body	Depth of gear pocket	0.2470	0.2485		
0.2480						
18	GEARS/SHAFTS/BODY BUSHES					
	Gear	Bore	0.2498	0.2508	0.0001	0.0010
			0.2503		0.0009	
	Shaft	Dia.	0.2494	0.2485	0.0003	0.0015
			0.2497		0.0011	
	Bush	Bore	0.2500	0.2512		
			0.2505			
	19	SEAL HOUSING ASSEMBLY				
		Length	0.3490	0.3390	Measured over housing and thrust washer	
			0.3550			

RESTRICTED

(659) Demand 90745 1100 9/65 T.T.P. Ltd., 4839

RESTRICTED

TABLE 3—(contd.)

Item No.	Part or description		Dimension new	Permissible worn dimension	Clearance new	Permissible worn clearance	Remarks
20	DRIVE SHAFT/DRIVE PIN	Shaft	Slot width	0.0985	0.1065	0.0055	
				0.0995			
	Pin	Dia.	0.0940	0.0865	0.0040		
			0.0945				
21	THRUST PLATE		Length	0.2450	0.2390		
				0.2500			
22	GLAND SPRING		Test length	0.2500	0.2500		
			Test load	3½ to 4 lb.	2½ lb.		
23	ARMATURE	Commutator	Dia.	0.9630	0.9060		
				0.9680			

This file was downloaded
from the RTFM Library.

Link: www.scottbouch.com/rtfm

Please see site for usage terms,
and more aircraft documents.

