

Chapter 4

PUMP, FUEL, FB6, Mk. 3

LIST OF CONTENTS

| | Para. | | Para. |
|---|-------|-------------------------|-------|
| Introduction | 1 | Upper pump casing | 24 |
| Reconditioning | | Impeller | 25 |
| Special tools | 4 | Lower pump casing | 27 |
| Dismantling | | Bottom cover | 31 |
| Bottom cover and lower pump casing | 7 | Suction and air filters | 32 |
| Impeller | 9 | Testing | |
| Motor | 11 | General | 33 |
| Bellows gland | 15 | Performance tests | 35 |
| Assembling | 16 | Gland leakage | 37 |
| Armature truth | 20 | Fuel delivery | 38 |
| Brushes | 21 | Insulation | 39 |
| Power output test To R.C.V.E. TEST | 22 | Protection | 40 |

LIST OF ILLUSTRATIONS

| | Fig. | | Fig. |
|-----------------------------------|------|-------------------------------------|------|
| Sectional view of FB6, Mk. 3 pump | 1 | Method of fitting new gland | 4 |
| Tool for gripping impeller | 2 | Relative position of pump and motor | 5 |
| Tool for gripping armature shaft | 3 | Temporary test rig | 6 |

LIST OF APPENDICES

| | |
|---|--------|
| Schedule of fits, clearances and repair tolerances (to be issued later) Part 8 | App. 1 |
|---|--------|

Introduction

1. Although the FB6, Mk. 3 pump is basically similar to others in the FB group, its overall design is different to facilitate interchangeability with certain other types of pump.

2. The FB pumps, for which general repair and reconditioning instructions are given in A.P.4343, Vol. 6, Sect. 16, Chap. 1, have the motor assembly outside the fuel tank, with the pump assembly extending into the tank. The totally enclosed and fuel sealed motor of the FB6, Mk. 3 pump (fig. 1), with the pump at its lower end, extends into the tank. The only portions of the unit on the exterior of the tank are the fuel outlet, gland drain plug, electric supply plug, and flame protected motor breathing aperture.

3. Since the general instructions for repair which are referred to above are applicable, except where details to the contrary are given in the following paragraphs, the above mentioned publication must be referred to in conjunction with this chapter when carrying out repair and reconditioning of the FB6, Mk. 3 pump.

RECONDITIONING

Special tools

4. In addition to the normal workshop tools and equipment the following demandable items will be required for reconditioning the FB6, Mk. 3 pump.

| | Part No. | |
|---|----------|---|
| Tool for gripping impeller | 92911 | — |
| Gauge for setting casing to give impeller clearance | 91580 | — |

~~RESTRICTED~~

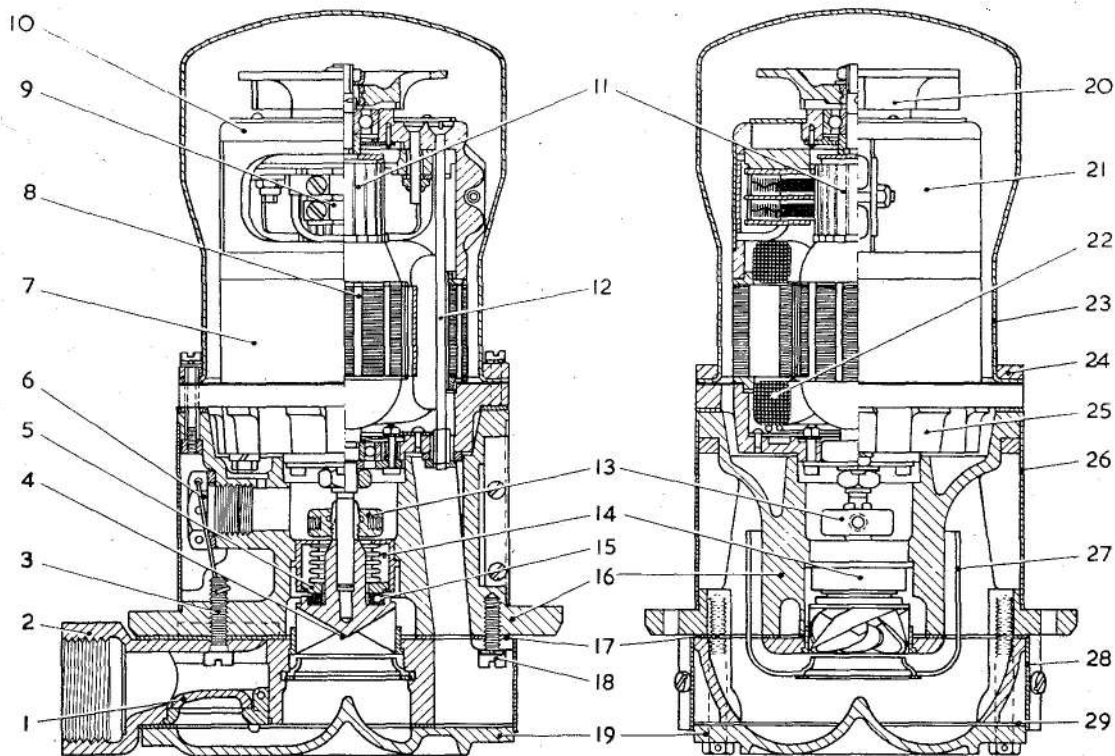

- | | | |
|-------------------------|----------------------------|-----------------------|
| 1 BY PASS VALVE | 11 COMMUTATOR | 21 COMMUTATOR COVER |
| 2 LOWER PUMP CASING | 12 THROUGH-BOLT | 22 FIELD WINDING |
| 3 LOCATING SCREW | 13 IMPELLER NUT | 23 MOTOR OUTER CASING |
| 4 IMPELLER | 14 GLAND | 24 SEAL CLAMPING RING |
| 5 GLAND RUBBERING RING | 15 IMPELLER RUBBERING RING | 25 IMPELLER END FRAME |
| 6 IMPELLER ACCESS PLUG | 16 UPPER PUMP CASING | 26 SUCTION FILTER |
| 7 MOTOR YOKE | 17 GASKET | 27 VAPOUR BAFFLE |
| 8 ARMATURE | 18 LOCATING SCREW | 28 AIR FILTER |
| 9 BRUSH ASSEMBLY | 19 PUMP COVER PLATE | 29 COVER GASKET |
| 10 COMMUTATOR END FRAME | 20 FAN | |

Fig. 1. Sectional view of FB6, Mk. 3 pump

| | | |
|---|----------|---|
| Sleeve for testing impeller truth | Part No. | |
| | 91648 | — |
| Impeller nut tommy bar | 92915 | — |
| Tool for pressing gland nut into casing | 00407 | — |

5. Other tools, which may be manufactured locally to supplement the standard tool kit, are described and illustrated as necessary. Their design may, in some instances, be modified to suit local requirements.

DISMANTLING

6. When dismantling the pump, the precautions given in A.P.4343, Vol. 6, Sect., 16, Chap. 1 must be observed especially with regard to cleanliness, avoiding damage to the impeller, marking mating parts, and safe retention of screws, clips, etc.

Bottom cover and lower pump casing

7. Remove the locking wire from the heads of the six screws in the bottom cover, take out the screws and gently prize off the cover. Care should be taken to avoid damaging the gasket. Remove the cylindrical filter

RESTRICTED

which surrounds the casing and replace the securing screws in their tapped holes.

8. The lower pump casing is retained to the upper casing by two locating screws. One of these (18, fig. 1) is visible and is locked by a spring washer only. To give access to the other screw (3, fig. 1), the by-pass valve must be pulled out from its housing in the lower casing. This screw is locked by a wire to the head of the impeller access plugs; remove this wire. Dismantle the electric supply plug and push the pin connectors of the plug, together with the motor leads, back into the casing of the pump. Unscrew and remove the two previously mentioned locating screws, and ease the lower pump casing from the upper casing.

Note . . .

When removing the lower casing, the greatest care must be taken to avoid damage to the impeller blades and to the sheet aluminium vapour baffle. The baffle should slide out of its slots quite easily when the lower casing has been removed.

Impeller

9. Remove the impeller access plug, turn the impeller with the fingers till one of the holes in the impeller nut may be seen through the access aperture and insert the end of the loose tommy bar, Part No. 92915 (fig. 2), into the hole in the impeller nut. Take the impeller gripping tool (Part No. 92911) in one hand and with the other hand hold the brass tightening screw by means of its short tommy bar until the jaws of the tool open sufficiently to pass over the impeller. Run the wing screw well back to ensure that it will not foul the end of the impeller and so prevent the tool being pushed right over the impeller. Push the tool over the impeller till it covers the blades and shroud and rotate the short tommy bar until the jaws of the tool close on the impeller. Then tighten the wing screw until the lip at the edge of the jaws engages on the back of the impeller. When

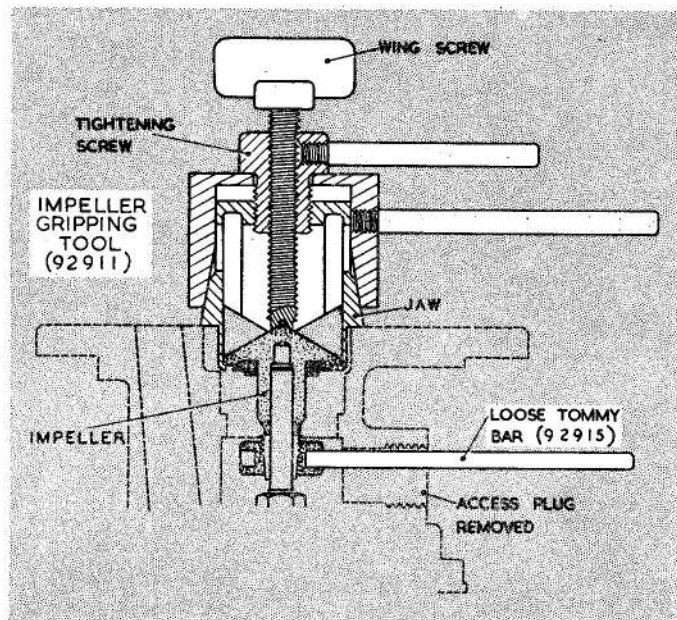

Fig. 2. Tool for gripping impeller

this has been done, tighten the jaws sufficiently to grip the impeller firmly, but do not use force, or the impeller will be damaged. Now remove the impeller from the shaft by turning the tool, at the same time holding the nut by the loose tommy bar and pulling the impeller squarely off the shaft.

10. Examine the impeller and if its condition is not satisfactory return it to Stores together with a demand for a new one. Alternatively, if the circumstances warrant such procedure, treat it as described in A.P.4343, Vol. 6, Sect. 16, Chap. 1, App. 1.

Motor

11. Remove the ten screws around the motor flanges, taking care to mark the split ring (under the upper pump casing flange) which is tapped to receive these screws. This will ensure that the ring is replaced in the same position as that from which it is taken. Ease away the joints at the sealing surfaces of the motor cover and motor flange and remove the cover and the motor. Take care not to lose the small driving pin, in the motor shaft, by placing it in a safe place till it is required again.

RESTRICTED

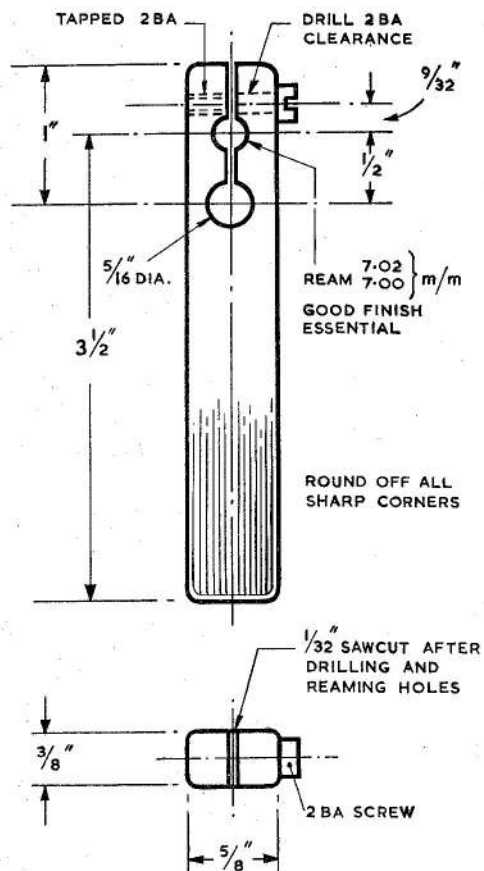

Fig. 3. Tool for gripping armature shaft

12. Test the shaft for eccentricity (which must not exceed ± 0.001 in.), remove and examine brushes and remove the fan (taking care not to lose its small driving peg), unscrew the motor through-bolts, but do not remove the brush-holder clamping bolts. Then separate the commutator end frame from the field yoke, leaving the yoke spigoted into the drive end frame. Unscrew the nut on the drive end of the armature shaft, either holding the armature by hand or by gripping the commutator end bearing seating with the special tool (fig. 3). Remove the nut and the slinger ring and extract the armature. Unscrew the retaining plates securing the drive end bearing and extract both the drive end and the commutator end bearing. These bearings may be extracted by gently tapping the inner race, using a soft brass or an aluminium drift.

13. Check the commutator for truth with a dial indicator and vee-blocks. The total permissible eccentricity is 0.001 in. (i.e.,

± 0.0005 in.); also check fits and clearances in accordance with the details given in Appendix 1 to this chapter.

14. The cleaning and examination of the field and armature coils, as well as the other components of the motor, are to be carried out in accordance with the instructions in A.P.4343, Vol. 6, Sect. 16, Chap. 1 and Appendix 1 to that chapter, especially observing the instructions pertaining to the non-removal of the brush-holder.

Bellows gland

15. At this stage, examine the gland for serviceability. The bronze sealing face, if in good condition, will have a smooth, polished appearance. Since the wear on this face is normally negligible over a working life of 500 hours, replacement of the gland will rarely be necessary. Where, however, the face is damaged or worn, a new gland must normally be fitted. Instructions for fitting a new gland, as well as temporary expedient measures, are given in A.P.4343, Vol. 6, Sect. 16, Chap. 1, App. 1. The special tool needed is shown in fig. 4.

ASSEMBLING

16. Fit new ball bearings in both the motor end frames. If the commutator end bearing has only one sideplate, the open side must be nearest to the commutator. Replace the retaining plates on both sides of the drive end bearing. Use a small amount of gasoline proof jointing compound to seal the retaining plate on the pump side of the drive end frame. Great care must be taken not to use too much compound or some may enter the interior of the bearing.

17. Assemble the armature into the bearing at the drive end and fit the insulation washer and then the distance piece on the commutator end of the shaft. Thread the electrical field coil leads through the holes in the commutator end frame and assemble the motor body. Tighten the motor through-bolts as evenly as possible and gently tap the end frames around their peripheries with a rawhide mallet to ensure that the end frames bed home fully.

18. Lock the through-bolts by peening the surrounding metal into the slots in the heads of the bolts. Alternatively, where locking tabs are fitted, these must be secured under the heads of the brush gear screws. The brush gear screws must be left loose until the through-bolts are fitted and tightened.

~~RESTRICTED~~

Swing the locking tabs into position over the heads of the through-bolts, tighten the brush gear screws and push one tag of each of the locking tabs into the screwdriver slot of the adjacent through-bolt.

19. Replace the slinger ring and apply two or three drops of gasoline proof jointing compound to the shaft at the centre of the ring. Fit the spring washer and tighten its associated nut by hand, or fit the "Twicklip" on models when this alternative method of securing is used. Fit the driving pin, fan, tab washer and fan securing nut, employing spacing washers where necessary to ensure clearance between the fan and commutator end frame. Tighten the fan nut with a box spanner whilst holding the drive end nut with another box spanner. When this has been done, check that the armature will spin freely.

Armature truth

20. When the fan has been fitted, check the armature for truth; eccentricity must not exceed ± 0.001 in. Check the spigot on the drive end frame for truth. This may be done by supporting the armature between lathe centres and rotating the motor body on the armature bearings, checking the truth of the spigot by bringing a dial indicator to bear on the spigot. The total range of movement must not exceed 0.002 in. It should be noted that unless the motor through-bolts have been tightened evenly, the drive end frame will not run true. If necessary, remove the fan, check the tightness of the through-bolts and again test for truth.

Brushes

21. Fit the numbered brushes in their correct holders; where new brushes are necessary, be sure to bed the brushes in on the commutator before putting the pump into service. In addition, temporarily connect the motor to a suitable 24-volt d.c. supply and run it on a load for a short while. During this trial run the current consumption should not exceed 3.0 amps.

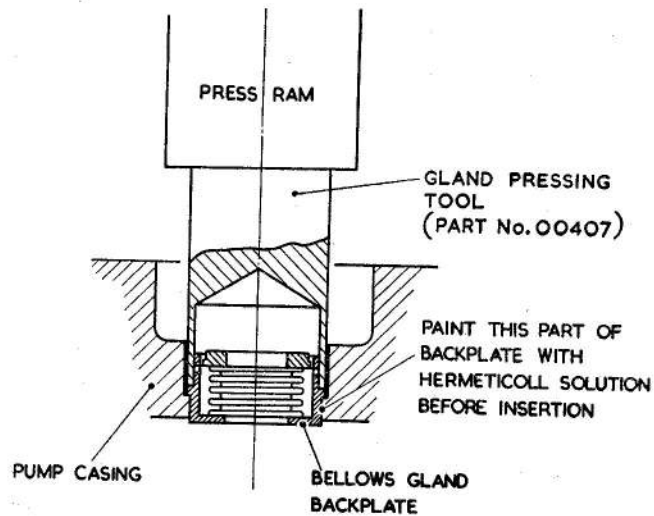

Fig. 4. Method of fitting new gland

When this test is completed, fit the commutator cover band assembly.

Torque test

22. Test the motor for power output on 24 volts and on 29 volts by means of a torque tester such as described in A.P. 4343, Vol. 6, Sect. 16, Chap. 1, App. 1. Fit a 1 inch radius pulley to the impeller shaft, place weights in the balance pan to cause the balance pointer to register, say 16 oz., and connect the motor to a 29-volt d.c. supply through a circuit similar to that shown in fig. 6.

23. Switch on the supply and adjust the input to the motor to 24 volts. When a speed of 8,400 r.p.m. is attained, the spring balance should record 6 oz., thereby indicating a torque of 10 oz. in. A similar test, with the input voltage adjusted to 29 should give 14 oz. in. torque when the motor attains a speed on 10,000 r.p.m.

Upper pump casing

24. Slip the impeller nut over the impeller shaft and insert the impeller driving pin in its position on the shaft, taking care to hold the motor assembly in such a position that the nut and pin will not fall out whilst fitting the pump casing to the

RESTRICTED

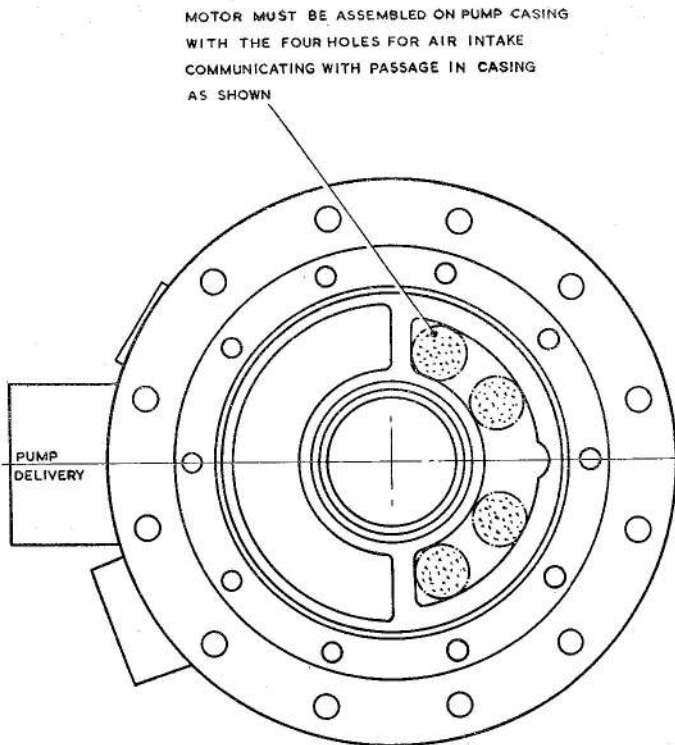

Fig. 5. Relative position of pump and motor

motor. Carefully feed the motor leads, complete with their soldered plug contacts, through the lead duct in the pump casing to the motor end frame. Ensure that these two components mate in such a way that the gauze covered holes in the motor end frame coincide with the air duct in the pump casing (*fig. 5*). Also make sure that the mating surfaces are clean and that a new jointing gasket is used. When this has been done, fit the motor outer casing (complete with clamping ring), insert the screws around the flange of the composite assembly and evenly tighten up the motor to the pump. It is essential that the pump shall seat squarely on the pump casing; otherwise the impeller, when fitted, will not run true in the impeller chamber and will tend to bind in the gland.

Impeller

25. Hold the impeller in the special tool (*para. 9*) and feed it on to the impeller shaft, engaging the driving pin on the shaft in one of the four slots in the impeller. The correct axial location of the impeller is reached when the face of the tool touches the face of the pump casing. At this point

secure the impeller by screwing the nut on to the impeller hub, this being achieved by inserting the nut tommy bar through the impeller access aperture and holding the nut, whilst the impeller is turned by means of the gripping tool.

26. When the impeller has been secured, it must be checked for concentricity, using the special sleeve (Part No. 91648) and the method described in Appendix 1 to A.P.4343, Vol. 6, Sect. 16, Chap. 1. The eccentricity must not exceed 0.002 in. (i.e., 0.004 in. range of movement). If necessary, try different angular positions of the impeller relative to the shaft to obtain true running.

Lower pump casing

27. Use a new gasket between the upper and lower casing and coat both its surfaces with gasoline proof sealing compound. Slide the aluminium suction baffle into position and secure the lower to the upper pump casing by means of the two locating screws (*para. 8*). Before tightening these screws, however, slip the setting gauge (Part. No. 91580) over the impeller, moving the lower case slightly if necessary to ensure the gauge sliding into the impeller chamber without moving the impeller from its correct axial position. Tighten the locating screws, remove the gauge and check the impeller clearance with a narrow feeler gauge. The clearance between the impeller and the wall of the impeller chamber must not be less than 0.003 in. at any point in the circumference. In addition, check that the tips of the blades of the impeller are flush with the end of the impeller chamber.

28. Slip the pin connectors of the motor leads through the hole in the side of the casing, assemble them into the electric supply plug and secure the latter on its seating on the pump casing.

29. Fit the by-pass valve in its housing, making sure that it seats squarely and that the two small projections on the bottom of the valve will locate into the bottom cover when the latter is finally fitted.

30. Push the suction baffle right home at the bottom of the impeller chamber and secure it by snapping on the circlip. Screw the impeller access plug, with its associated aluminium sealing washer, into position, and wire the plug to the lower casing locating screw (*para.* 8), located below it.

Bottom cover

31. Fit the bottom cover to the base of the lower pump casing with a new gasket (coated with gasoline-proof sealing compound) interposed between the casing and cover. Insert the six long securing screws around the circumference of the cover, taking care to tighten the screws at opposite sides alternately in order to avoid distorting the cover. When this has been done, lock the screws and the drain connection by a wire passing through the holes of all of them.

Suction and air filters

32. Fit the air filter around the lower casing and the cylindrical suction filter around the upper casing, using the screws which were replaced in their tapped holes. It is essential that the suction filter is not distorted and is a snug fit round the pump or it will not permit the pump to be inserted in the fuel tank when it is installed in the aircraft.

TESTING

General

33. A suitable test rig capable of testing this and other similar pumps is being developed and will be described in A.P.4343S, Vol. 1, Sect. 10. Pending the issue of this information, a simple temporary test rig on the lines of that shown in fig. 6 may be set up.

34. The ammeter must be capable of passing 10 amp., whilst the voltmeters must be able to handle a minimum of 30 volts. The tank must be of ample size to hold sufficient fuel to enable the operator to maintain a head of fuel at least six inches

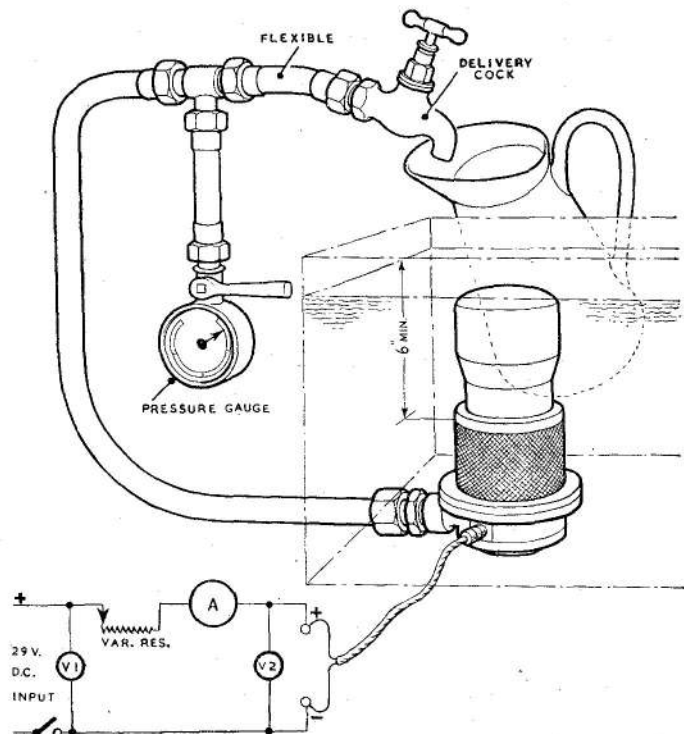

Fig. 6. Temporary test rig

above the top of the pump suction filter. The jug or other receptacle should be of known capacity to enable the operator to measure the quantity of fuel delivered by the pump.

Performance tests

35. Connect the test rig to a 29-volt d.c. supply and adjust the resistance to supply 12 volts to the pump motor, with no fuel in the tank. Gradually vary the resistance to increase the voltage to 24. The motor must rotate before the voltage exceeds 16. At 24 volts the motor is to be kept running for not more than five minutes, during which period the current consumption must not exceed 5 amp. Switch off the supply and fill the tank to the requisite level.

36. Switch on the supply, adjust the pump input voltage to 22, and run the pump at this setting for one hour, with the delivery cock so adjusted as to give a delivery pressure of 8 lb. per sq. in. Switch off, adjust the voltage to 29, and again run the pump for one hour. The current consumption and

RESTRICTED

fuel delivery rate at the start and conclusion of these runs are to be recorded. If any appreciable change in performance takes place, the tests must be repeated until steady results are obtained.

Gland leakage

37. Run the pump on 29 volts, with the delivery cock closed, for a few minutes and carefully examine all joints and gaskets for leakage. The maximum permissible gland leakage during running periods is two drops per minute when running in gasoline and four drops when running in kerosine. When the pump is stationary the permissible leakage is one drop of gasoline per minute and two drops of kerosine. If the gland leakage is slightly in excess of these figures, the pump is to be run for a short time on load until the gland has bedded itself in. In the event of serious leakage, the tests must be discontinued and the cause of leakage ascertained.

Fuel delivery

38. With a head of fuel of six inches over the pump inlet and the delivery pressure varied from the minimum up to the maximum, in steps of 5 lb. per sq. in., the delivery rate and current consumption are to be measured at each stage for input voltages

of 22, 24 and 29. The results obtained should compare favourably with the following :—

| volts | lb. per sq. in. | G.P.H. (min.) | amps (max.) |
|-------|-----------------|---------------|-------------|
| 22 | 5 | 400 | 6.5 |
| 24 | 9-12 | 200 | 7.0 |
| 29 | 10 | 450 | 7.5 |

Insulation

39. The insulation resistance must be tested prior to starting, and after completing the performance tests (para. 35 to 38) *whilst the motor is still warm*. The insulation resistance must not be less than 2 megohms.

Protection

40. In all instances when the pump is not to be put into immediate service, protective caps must be fitted on the delivery and drain connections. As an alternative, where suitable caps are not available, pieces of clean rag or other suitable material may be tied over the connections to prevent the ingress of foreign matter. If the pump is to be put straight into service, it must be fitted to the fuel tank immediately the tests are satisfactorily completed.

~~RESTRICTED~~

APPENDIX I

SCHEDULE OF FITS, CLEARANCES, AND REPAIR TOLERANCES
(FB. 6, Mk. 3, FUEL PUMP)

(All dimensions in inches)

| Ref. No. on Diagram (1) | Parts and Description (2) | | Dimension, New (3) | Permissible Worn Dimension (4) | Clearance, New (5) | Permissible Worn Clearance (6) | Remarks (7) |
|----------------------------------|--|--|---------------------------|---|--------------------------|---|--|
| | MOTOR ASSEMBLY | | | | | | |
| 1 | BRUSH LENGTH | Measured to centre of radius | 0.4275 0.4475 | 0.330 | — | — | Brush shortens approx. 0.010 in 250 hours |
| 2 | BRUSH SPRINGS | Free length Compressed length Load in position | 0.875 0.375 4.0 oz. | — 0.482 3.0 oz. | — — — | — — — | Pigtail is not taut at the permissible worn dimension quoted. Actual length of pigtail in spring 0.70 |
| 3 | BRUSH CLEARANCE IN GUIDES | | — | — | 0.007 | 0.013 | |
| 4 | COMMUTATOR | | 0.990 1.002 | 0.970 | — | — | Diameter reduces approx. 0.001 in 250 hours |
| 5 | BALL BEARINGS | End float between inner and outer races | — | — | 0.002 | 0.004 | |
| 6 | PUMP ASSEMBLY IMPELLER CHAMBER | Bore of bush | 1.250 1.252 | 1.255 | 0.0145 | 0.022 | Should not be worn by contact but may be scratched by abrasives in fuel. Minimum radial clearance (allowing for impeller eccentricity) should not be less than 0.003 |
| | IMPELLER | Diameter | 1.2345 1.2355 | 1.233 | 0.0175 | | |
| 7 | IMPELLER | Maximum eccentricity | 0.004 | — | — | — | Indicator reading |

RESTRICTED

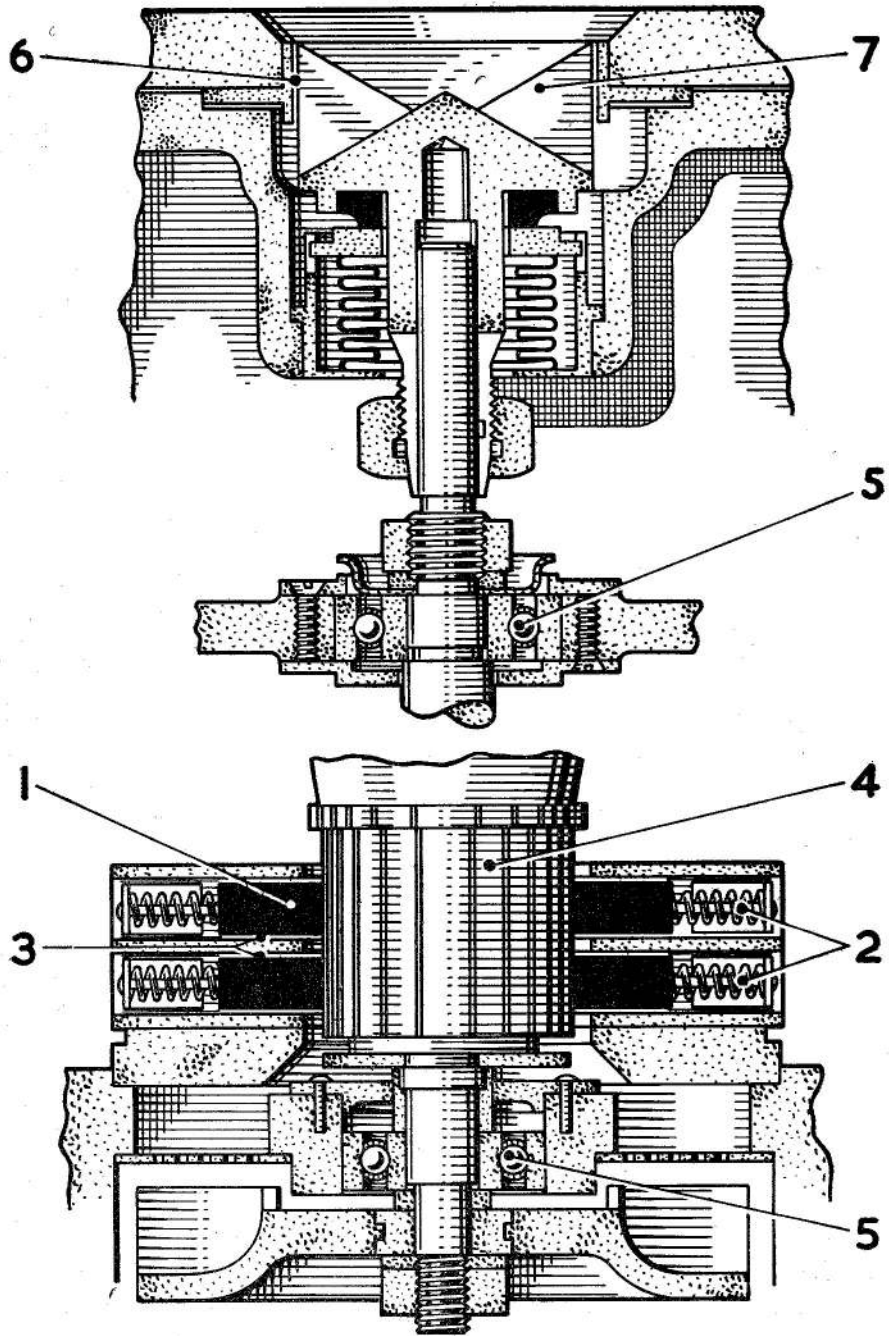

Diagram 1. Pump, fuel, FB6, Mk.3

This file was downloaded
from the RTFM Library.

Link: www.scottbouch.com/rtfm

Please see site for usage terms,
and more aircraft documents.

