

**Chapter 40**

**PUMP, FUEL, PDC 810**

**LIST OF CONTENTS**

	<i>Para.</i>		<i>Para.</i>
<b>Dismantling</b>		<i>Continuity resistance test</i> ... ..	44
<i>General</i> ... ..	1	<i>Performance test</i> ... ..	45
<i>Pump</i> ... ..	5	<i>High voltage test</i> ... ..	46
<i>Motor</i> ... ..	11	<i>Insulation resistance test</i> ... ..	47
<b>Inspection and Repair</b> ... ..	14	<i>Rating of motor and speed control</i> ... ..	48
<i>Motor and pump</i> ... ..	15	<i>Refuelling requirements</i> ... ..	49
<b>Re-assembly</b> ... ..	21	<i>Starting test</i> ... ..	50
<b>Testing</b>		<i>Dry running test</i> ... ..	51
<i>General</i> ... ..	41	<i>Gland leakage tests</i> ... ..	52
<i>Running light test</i> ... ..	42	<i>Calibration test</i> ... ..	53
<i>Overspeed test</i> ... ..	43		

**LIST OF ILLUSTRATIONS**

	<i>Fig.</i>		<i>Fig.</i>
<i>Cutaway of complete pump</i> ... ..	1	<i>Sleeve for testing impeller truth</i> ... ..	6
<i>Pump unit dismantled (major components)</i>	2	<i>Impeller/suction cover, clearance gauge</i>	7
<i>Suppressor and resistance assemblies</i> ...	3	<i>Circuit diagram</i> ... ..	8
<i>Exploded view of actuator</i> ... ..	4	<i>Test rig</i> ... ..	9
<i>Tool for pressing in bellows gland</i> ...	5		

**LIST OF TABLES**

	<i>Table</i>		<i>Table</i>
<i>Special tools</i> ... ..	1	<i>Calibration test figures</i> ... ..	3
<i>Inspection, Rectification of faults</i> ...	2	<i>Schedule of parts</i> ... ..	4

**LIST OF APPENDICES**

	<i>Appendix</i>
<i>Schedule of fits, clearances and repair tolerances</i> ... ..	1

## DISMANTLING

### General

1. A complete overhaul may be carried out by approved R.N. and R.A.F. maintenance units having the necessary machinery facilities and test equipment. Where these facilities are not available the pump must be returned to the manufacturer for repair and reconditioning.

2. The special tools listed here will be needed during dismantling and reassembly procedure.

3. The following paragraphs describe the dismantling of the component to its individual parts. Where complete dismantling is considered unnecessary, the technician may select the relevant paragraphs and carry out the work only as far as is required.

4. The numbers in parenthesis correspond to the item numbers in fig. 2, 3 and 4. A schedule of parts is shown in Table 4.

### Pump

5. Remove cover plate (36) and joint (35) by removing twenty one screws (39), lockwashers (38) and washers (37).

6. To dismantle resistances and suppressors, first push back sleeves, expose soldered joints and unsolder. Remove the three resistances (64), loosen nuts (68) and slip out. Leave brackets (65) in position, unless damaged and requiring replacement. Next, slacken off screws (70), which enable the three suppressors (73) to slide out as required between clamp (72) and clamp bracket (74).

It is unnecessary to remove the cable bracket (78), tensioned by screws (80) unless renewal is anticipated.

7. Take out the three screws (17) and lockwashers (18) to remove clips (19) which hold suction strainer (1). Remove five screws (2) and lockwashers (3) to free suction baffle (4). Remove five screws (5) to release suction cover (7) with slipring (6) and joint (8). The slipring is a press fit.

8. To remove impeller (9), depress, turn in an anti-clockwise direction to the limit, then pull to release. (action is similar to removing an electric light bulb from a B.J. lamp holder). Do not remove carbon ring seal (12) unless it is intended to renew same. Remove end plate of metal bellows gland (13) by depressing and turning until four keyways are in line with keys. Remove bellows gland, shaft pin (93), washer (10) and double spring lockwasher (11) from shaft.

9. Four csk.hd. screws (21) are removed with their lockwashers (22) to release by-pass valve seat (23) and joint (24). Pull out hinge pin (32) to free spring (31). By-pass valve flap (29), joint (26 or 27) and cover plate (25) are assembled with rivets and need not be segregated unless it is found necessary to renew joint.

10. Remove three nuts (55) and lockwashers (54) and lift off top canister (56). Remove three distance pieces (53), nine screws (51), three long screws (52) together with twelve lockwashers (50), which will then release clamping ring (107), motor cover plate (108),

TABLE 1

### Special Tools

Description	Part No.	Fig. No.
Sleeve for testing impeller truth ... ..	021288	5
Tool for pressing in bellow gland ... ..	00407	6
Impeller/suction cover clearance gauge ...	021289	7

These tools are illustrated in this chapter.

**RESTRICTED**

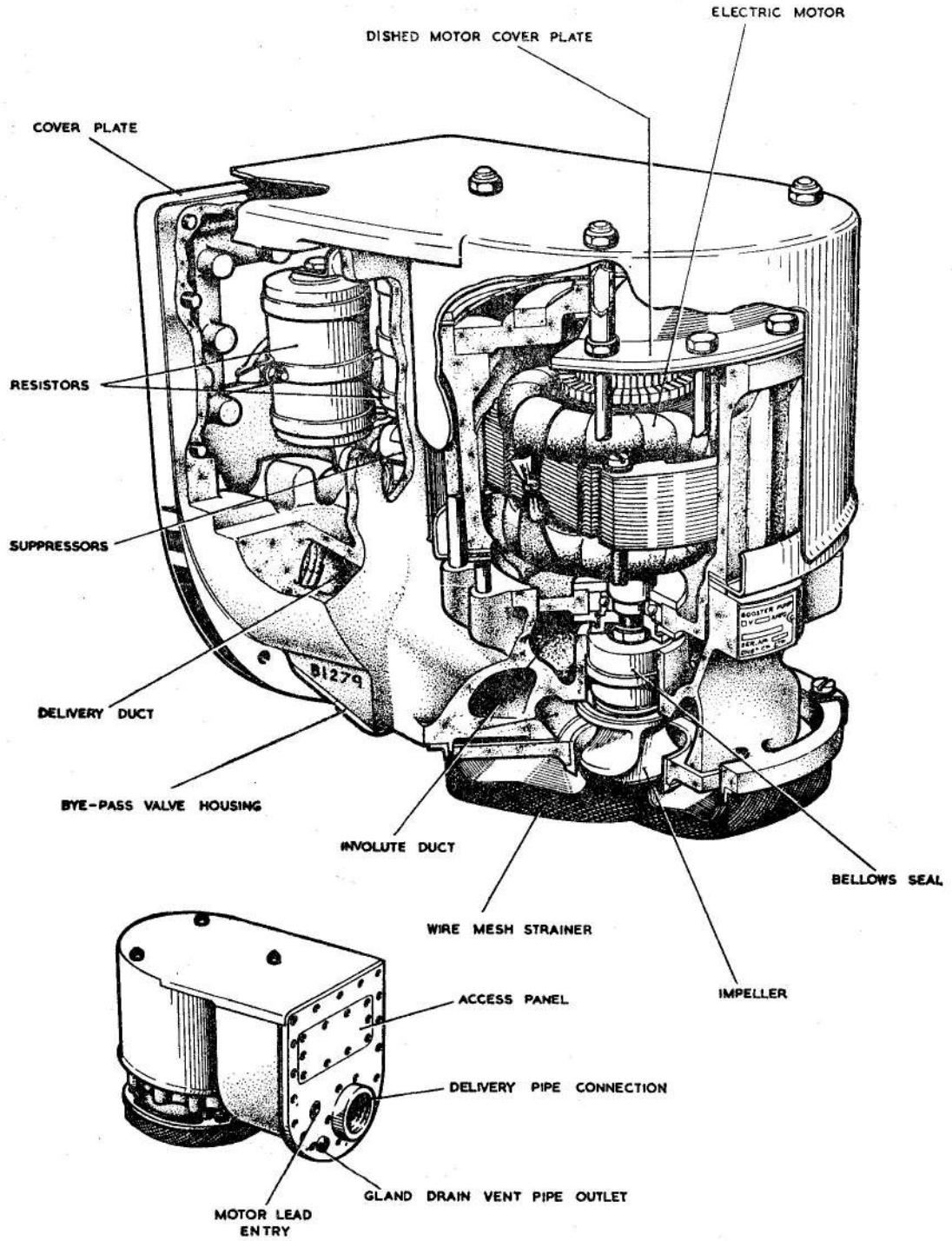

Fig. 1. Cutaway of complete pump

F.S./2

**RESTRICTED**

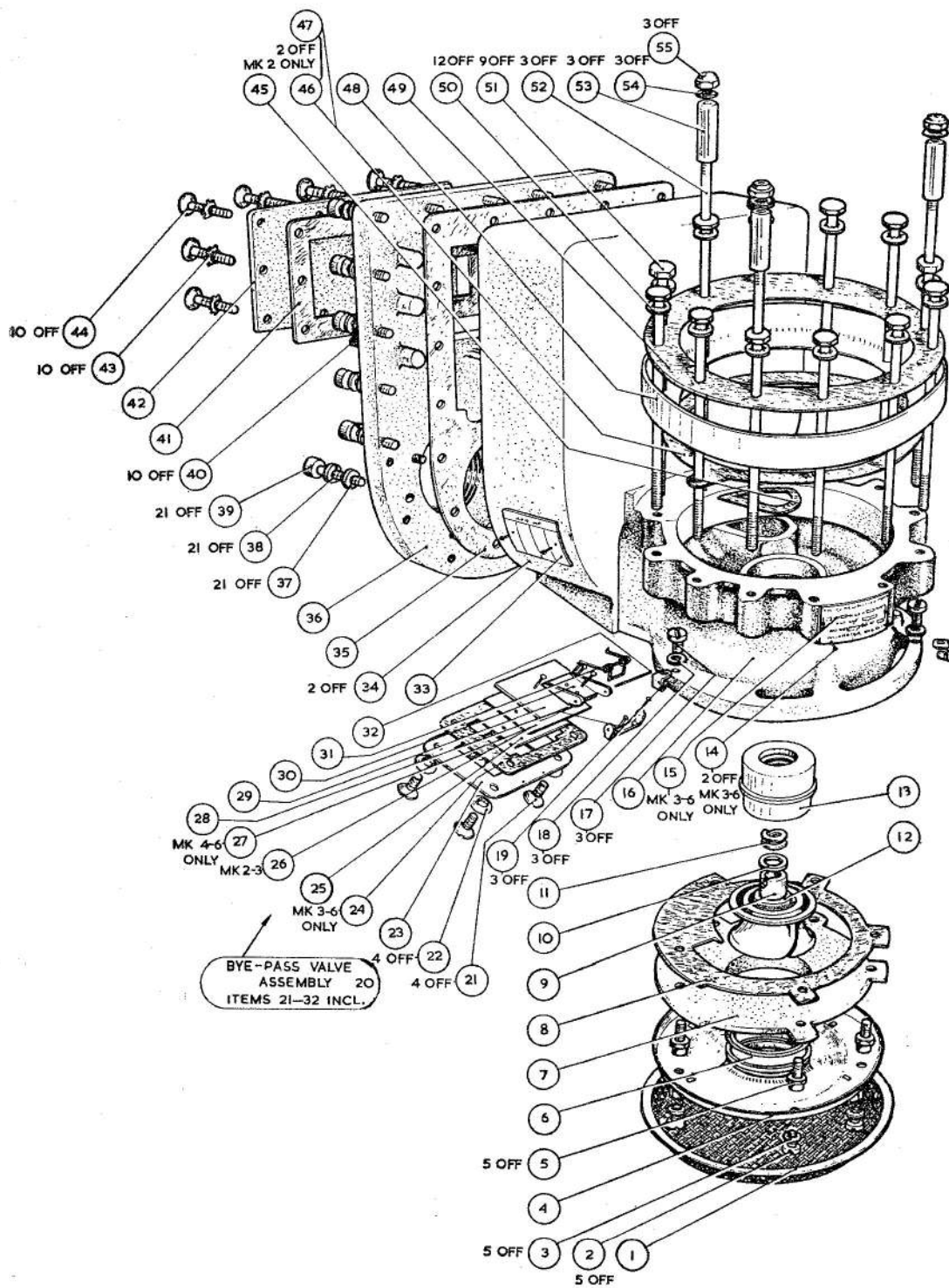

Fig. 2. Pump unit dismantled (major components)

~~RESTRICTED~~

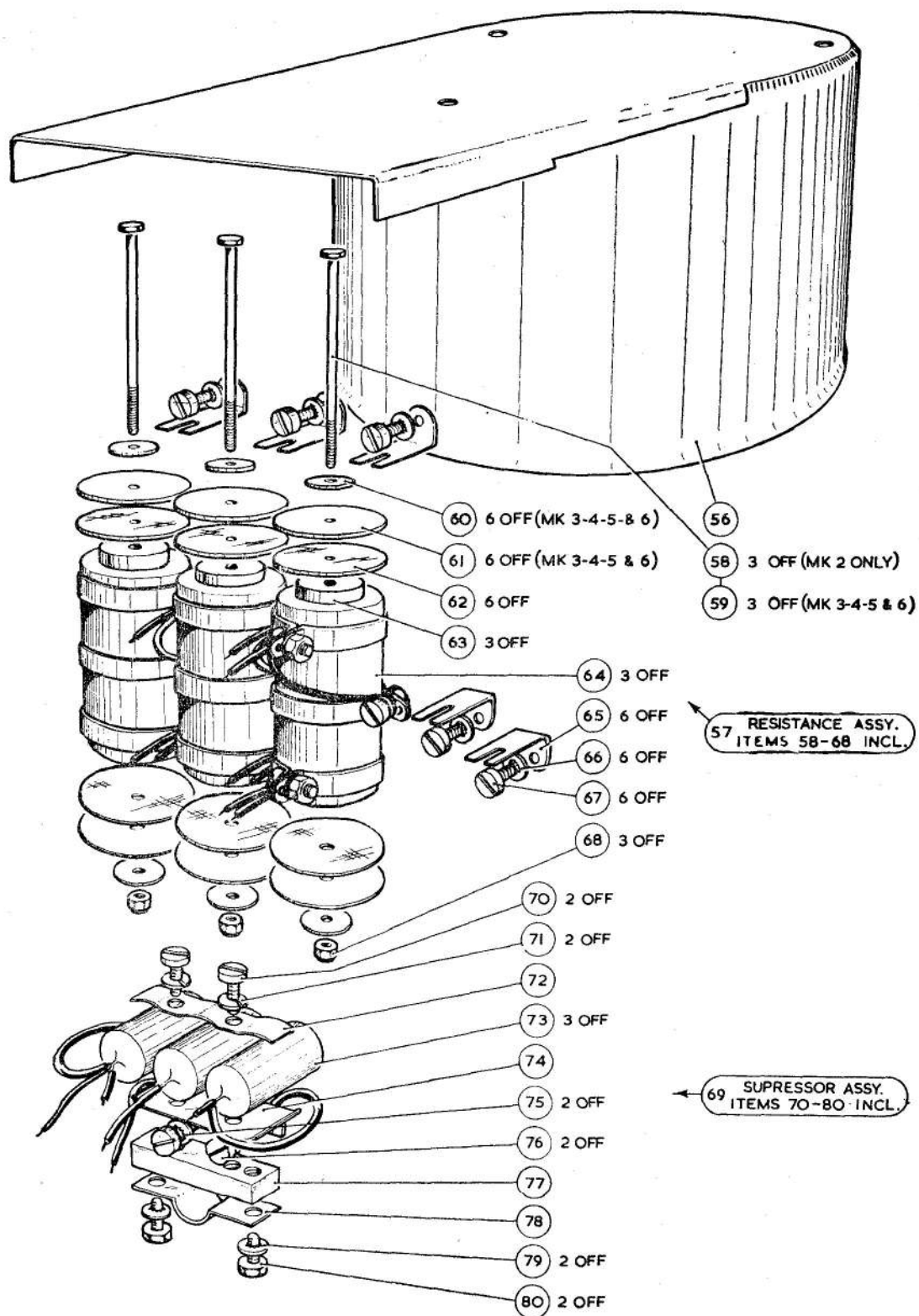

Fig. 3. Suppressor and resistance assemblies

**RESTRICTED**

gasket (109), joint (49), bottom cannister (48) and joints (46 or 47). This will automatically release the motor from its housing. Care must

be taken not to damage motor leads. Electrical connection seal joint (45) should then be removed and discarded.

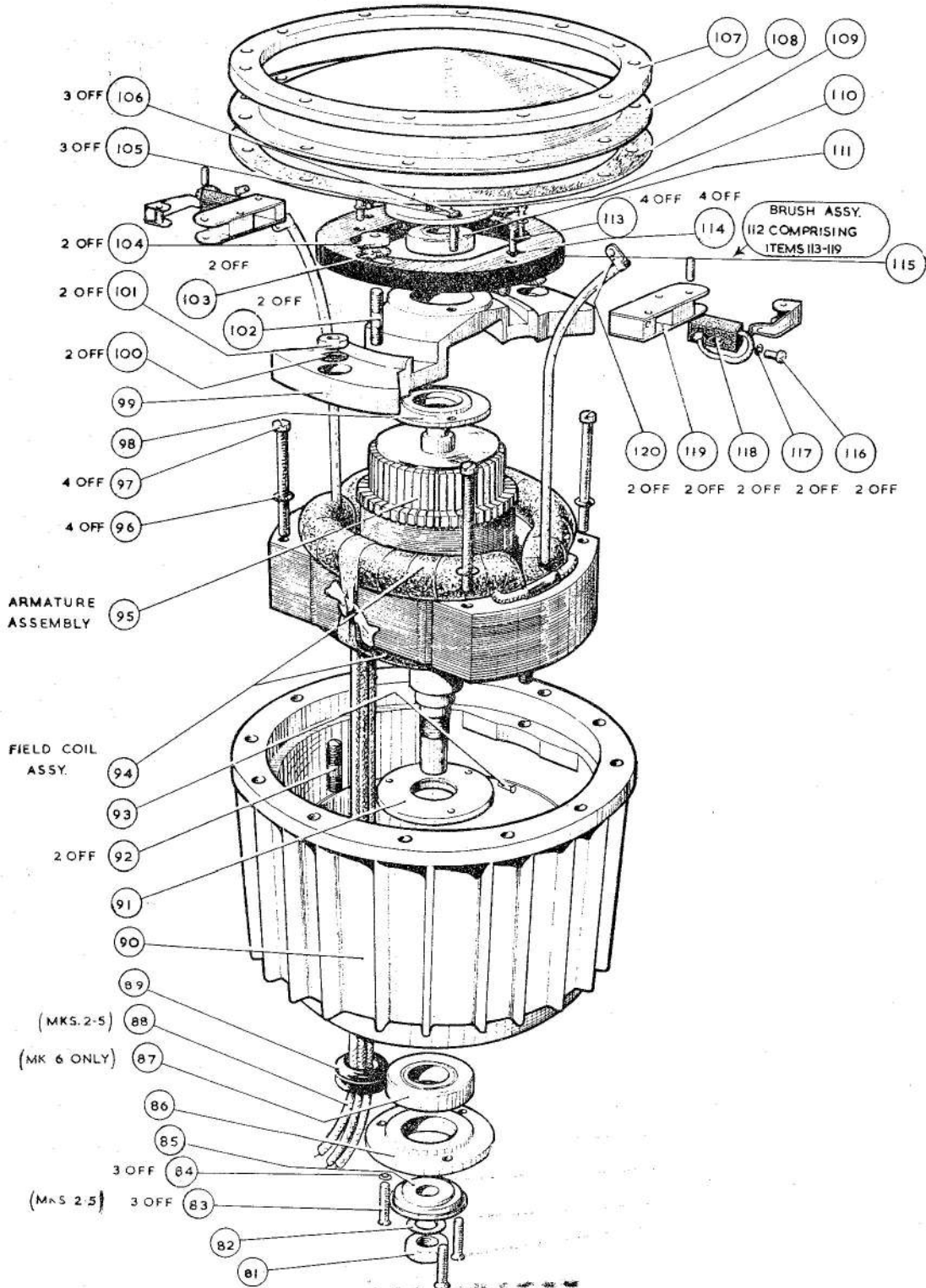

Fig. 4. Exploded view of motor

~~RESTRICTED~~

**Motor**

11. Remove two screws (116), plain washers (117), thus releasing carbon brush (118) and field coil connections from brush holders (119), marking them to ensure they are re-assembled in the same position. Remove two nuts (101) and lockwashers (100). Lift off bearing bracket (99) with bearing and rocker attached. Next remove three screws (106) and lockwashers (105), freeing grease plates (98 and 110) and bearing (111).

12. The brush rocker (115) can be separated from the bearing bracket by removing two nuts (104) and lockwashers (103). The two brush holders are freed from the rocker by removing four screws (113) and lockwashers (114).

13. Hold armature shaft firmly by the flats at commutator end to loosen nut (81)

with ring spanner, taking care not to damage the shaft. After removing nut (81) lockwasher (82) and fuel thrower (85), carefully lift out the armature and assembly (95). Remove three screws (83) and lockwashers (84) which allow the removal of grease plates (86 and 91) and bearing (88 or 87). Remove four screws (97), lockwashers (96) and lift out the field coil assembly. Do not detach the field coils from the pole pieces.

**INSPECTION AND REPAIR**

14. The armature (excepting commutator) and field coil assemblies are cleaned with rag moistened with white spirit, taking care to avoid lowering the insulation of the windings and end connections etc. The commutator may be thoroughly cleaned with clean white linen. All other pump and motor components may be washed in white spirit and wiped thoroughly dry. Test electrical connections to ensure they are sound.

TABLE 2

## Inspection, and Rectification of faults

Item	Inspection	Action if faulty
Armature	Insulation resistance to armature shaft. Use a 500 volt megger	Prolonged drying at 120 deg. C. when thoroughly clean, until infinity reading is obtained.
	Commutator for loose conductors.	Reject for rewinding.
	Dirty commutator	Clean with white linen
	Commutator for scoring and burnt segments.	Skim commutator. The minimum permissible dia. for further use is 1.59 in. Undercut slots with clean blade of suitable thickness. Commutator to be true with shaft to within 0.003 in clock reading.
	Fouling of armature and pole pieces.	Examine bearings for side play. Renew if faulty. Check armature shaft for eccentricity (max. 0.001 in. Replace armature if defective).
	Resistance of armature 0.154 to 0.162 ohms.	Renew if faulty
	Short or open circuited conductors. Use voltage drop tester or growler.	Clean undercutting on commutator. If still unsatisfactory reject armature.
Field coil assembly	Insulation resistance to frame.	Prolonged drying when clean, at 120 deg. C., until infinity reading is obtained on megger.
	Continuity resistance of coils. Use a 500 megger.	Reject field.
	Visible condition of field coils.	If coils are damaged, renew field coil assembly.
	Visible condition of field coils leads, insulation covering.	If damaged, cover with additional sleeving.
	Continuity resistance of each winding Series:—0.018 to 0.022 ohms Shunt:—3.33 to 4.00 ohms when measured at 15 deg. C.	Renew complete field assembly.

**RESTRICTED**

TABLE 2—contd.

Inspection, and Rectification of faults—contd.

Item	Inspection	Action if faulty
Brushgear	Visible condition of each part	If damaged or corroded, renew.
	Brushes for wear Minimum permissible length is 0.5625 in.	Renew
	Tension of each brush spring 12 to 15 oz.	Renew brush holder assembly
	Fit of brushes in brush boxes.	Brushes should slide freely in their boxes. All traces of carbon dust must be removed.
Resistances and suppressors	Test for continuity resistance using a 500 volt megger. Capacitors must be disconnected for this test.	Renew if faulty.
Bearings	Damaged	Renew
	Friction present in turning Excessive side play Excessive end play (0.004 in. max.)	Renew Renew Renew
Metal bellows fuel sealing gland.	Bellows distorted or damaged. 2 lb. load depresses length to less than 0.422 in. or more than 0.469 in.	Renew
	Sleeve seal damaged	Renew
Impeller	Wear and scoring of carbon seal face.	If slight, relap to a mirror finish. If excessive, renew impeller.
Strainers	Damaged gauze mesh	Renew
Bye-pass valve	Seal between valve flap and seating. (Faces should be lapped together).	Renew

### Motor and pump

15. If the field coils are proved to be un-serviceable, no attempt must be made to rectify them. The complete field assembly must be replaced with a new one. Repairs to the field coil leads, where faulty insulation is concerned may be carried out, or baking of the assembly where insulation tests are low due to dampness.

16. The commutator must be lightly skimmed and polished, ensuring that after this operation the diameter is not less than 1.59 in. After skimming, the insulation slots must be cleaned of burrs, and the armature blown out with low pressure compressed air. The commutator must run true with the shaft within 0.0003 in. clock reading.

17. Examine the brushes for wear, and, if worn below 0.5625 in. on longer edge, they should be renewed. If they are still usable, it is important that they are returned to their original boxes (having been suitably marked before dismantling). The brushes must slide freely in their boxes, and, if there is any sign of corrosion of the brushgear, the brush box assembly must be renewed. Examine the condition of the wound brush springs and renew if the tension falls below 12 oz.

18. The field assembly and motor end covers should be cleared of carbon dust etc., using dry compressed air; if new brushes are fitted, they must be bedded to the commutator. It is recommended that each brush should bed over its full width of arc, with at least 80 per cent of its face contact area. After this operation, take out the newly bedded brushes, remove the armature and blow out with low pressure, dry compressed air, prior to final assembly.

19. Examine the condition of the bearings. Ensure that the grease shields are not damaged in any way, suggesting possible cracking or breaking of the ball cages. Holding the outer race between the fingers, slowly rotate the inner race, feeling for any roughness of the tracks; check also for excessive side and end play. Should any of the above faults be evident, the bearings should be replaced with new.

20. The motor is now ready to be re-assembled.

### RE-ASSEMBLY

#### Note. . .

*All joints and lockwashers to be renewed when re-assembling.*

21. Position bearing (87 or 88) in drive end of stator housing (90) and encase by replacing screws (83) and lockwashers (84) to secure grease plates (86 and 91).

22. Carefully replace field coil assembly (94) in stator housing so that the motor leads line up with, and are threaded and drawn through hole in the drive end housing; see that cable grommet is adjusted correctly. Replace the four screws (97) with lockwashers (96) to secure the field coil assembly to the stator housing. Replace the two studs (92) in position.

23. Enter the armature (95) into position, taking care not to foul the prepositioned drive end bearing. Press fuel thrower (85) in drive end outer grease plate (86) and, holding flats of armature shaft firmly, replace lockwasher (82) and nut (81).

24. Replace electrical seal joint (45), which is to be affixed to the casting with a fuel resisting metal to rubber compound (Hermeticol). It is essential to ensure that the face is thoroughly clean and free from grease before attempting this operation.

25. Similarly affix motor to casing joint (46 or 47), first ensuring that the twelve holes of the gasket are placed centrally with the corresponding holes in the casting, and are not obstructed, secondly that the bleed hole remains clear. Fix joint (49) and bottom canister (48) to base of stator housing (using Hermeticol), ensuring that all holes are unobstructed.

26. Take the three long motor screws (52) and in conjunction with top canister, mark their hole positions on the pump yoke. Remove for assembly at a later stage.

27. Lower motor into position, carefully pushing motor leads down the breather duct, with the grommet at base of stator housing, resting centrally over the electrical seal connection joint (45).

~~RESTRICTED~~

28. Insert six of the nine short motor screws (51) with clamping ring and washers in lieu of end cover (108) and gasket (109). These screws should be equally spaced round the twelve holes of the stator housing and lightly tensioned. Apply Hermeticol to frame of metal bellows fuel sealing gland, and, using special tool 00407, (fig. 5) press home into casting.

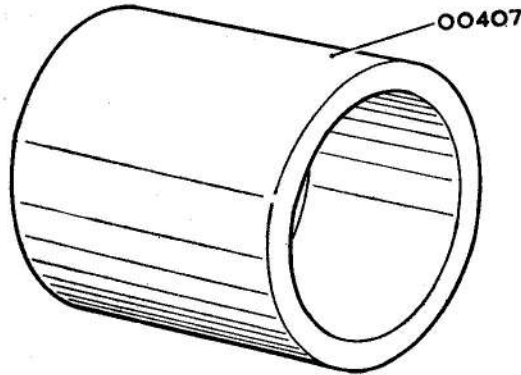

Fig. 5. Tool for pressing in bellows gland

29. Insert double spring lockwasher (11) washer (10) and shaft pin (93).

30. Replace impeller (9) by depressing, and turning in a clockwise direction to lock. The carbon ring is then in contact with end plate

of metal bellows gland. At this stage, the impeller is checked for concentricity by using tool 021288 (fig. 6).

31. Remove the six temporarily positioned short motor screws and clamping ring from top of stator housing. Place the gasket (109), motor cover plate (108) and clamping ring (107) into position, replace the nine short screws (51) three long motor screws (52), with their lock washers (50) in their appropriate positions and lightly secure. Tighten these screws in diametrically opposites sequence, thus applying equal pressure until joints are tightly compressed.

32. Screw studs (102) in bearing bracket (99). Position commutator end bearing (111) in bearing bracket and replace inner and outer grease plates (98) and (110) respectively. These encase the bearing and are held in position by three screws (106) and lockwashers (105). Replace the bearing bracket by fixing two nuts (101) and lockwashers (100) to studs (92).

33. Re-assemble brush holder (119) and fix to rocker (115) with four screws (113) and lockwashers (114). Secure rocker to bearing bracket with two nuts (104) and lockwashers

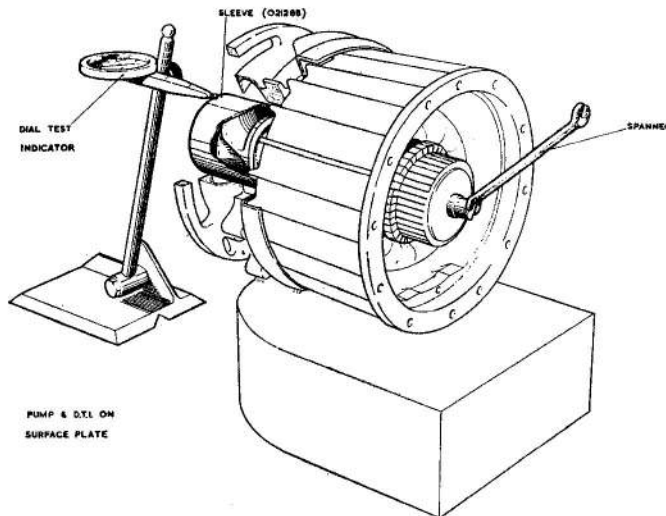

Fig. 6. Sleeve for testing impeller truth

**RESTRICTED**

11	Lockwasher, 1/4" Double spring	...	...	BSS. SP55/E	2-6	1
12	Ring, carbon	...	...	99269	2-6	1
13	Gland, metal bellows	...	...	99267	2-6	1
14	Screws, drive	...	...	F/11788	3-6	2
15	Nameplate,	...	...	015701	3-6	1
16		...	...	015301	2-6	1

**TABLE 3**  
**Calibration test figures**

Speed class	Fuel flow in gallons per hour	Pressure in lb. per sq. in.	d.c. voltage
Low altitude medium speed	900	Not less than 10.5	26
Low altitude medium speed	Closed valve	16 to 17	26
Low altitude fast speed	Closed valve	18.5 to 20	26
High altitude fast speed	Closed valve	17 to 18	26
High altitude medium speed	Closed valve	15 to 16	26
Slow speed	Closed valve	9 to 13.5	26

The maximum current is 16 amperes.

**TABLE 4—contd.**  
**Schedule of Parts—PDC 810 Tank Fuel Pump.**

Item No.	Description	Makers Part No.	Mk.	No. off per pump
25	Plate, cover ... ..	015671	2-6	1
26	Joint, ... ..	015672 Iss. 1	2-3	1
27	Joint, ... ..	015672 Iss. 3	4-6	1
28	Hinge seat, ... ..	015668	2-6	1
29	Flap, by-pass valve ... ..	015669	2-6	1
30	Hinge, flap ... ..	015670	2-6	1
31	Spring, ... ..	015673	2-6	1
32	Pin, hinge, ... ..	015353	2-6	1
33	Modification plate, ... ..	021243	4	1
34	Screws, drive, ... ..	F/11788	4	2
35	Joint, cover plate ... ..	015647	2-6	1
36	Plate, cover ... ..	015375	2-6	1
37	Washers, 2 BA. 26 SWG. plain ...	BSS.SP10/C	2-6	21
38	Lockwashers, 2 BA. spring ... ..	BSS. SP47/C	2-6	21
39	Screws, 2 BA. cheese head $\times \frac{5}{8}$ " long	BSS. A31/C20	2-6	21
40	Cross wire thread inserts $\frac{5}{8}$ "	2 BA	2-6	10

28. Insert six of the nine short motor screws (51) with clamping ring and washers in lieu of end cover (108) and gasket (109). These screws should be equally spaced round the twelve holes of the stator housing and lightly tensioned. Apply Hermeticol to frame of metal bellows fuel sealing gland, and, using special tool 00407, (fig. 5) press home into casting.

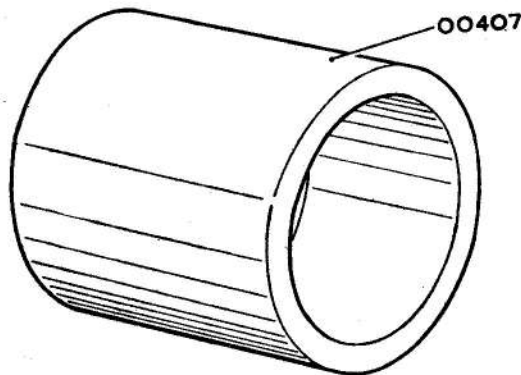

Fig. 5. Tool for pressing in bellows gland

29. Insert double spring lockwasher (11) washer (10) and shaft pin (93).

30. Replace impeller (9) by depressing, and turning in a clockwise direction to lock. The carbon ring is then in contact with end plate

of metal bellows gland. At this stage, the impeller is checked for concentricity by using tool 021288 (fig. 6).

31. Remove the six temporarily positioned short motor screws and clamping ring from top of stator housing. Place the gasket (109), motor cover plate (108) and clamping ring (107) into position, replace the nine short screws (51) three long motor screws (52), with their lock washers (50) in their appropriate positions and lightly secure. Tighten these screws in diametrically opposites sequence, thus applying equal pressure until joints are tightly compressed.

32. Screw studs (102) in bearing bracket (99). Position commutator end bearing (111) in bearing bracket and replace inner and outer grease plates (98) and (110) respectively. These encase the bearing and are held in position by three screws (106) and lockwashers (105). Replace the bearing bracket by fixing two nuts (101) and lockwashers (100) to studs (92).

33. Re-assemble brush holder (119) and fix to rocker (115) with four screws (113) and lockwashers (114). Secure rocker to bearing bracket with two nuts (104) and lockwashers

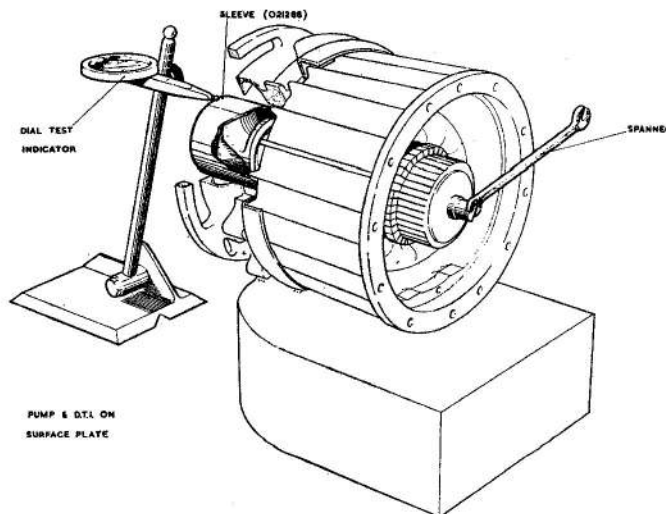

Fig. 6. Sleeve for testing impeller truth

~~RESTRICTED~~

(103). Pull back spring clips and slide two brushes (118) into their respective holders, releasing the spring clips to hold the brushes to the commutator. Next, replace two screws (116) and plain washers (117) to connect tags (120) from brushes and field windings to brush holder (119). Replace the three distance pieces (53). Top canister (56) is then secured with three nuts (55) and lockwashers (54). Fit joint (8) and suction cover (7) to casing by replacing five screws (5) and press slipping (6) into position.

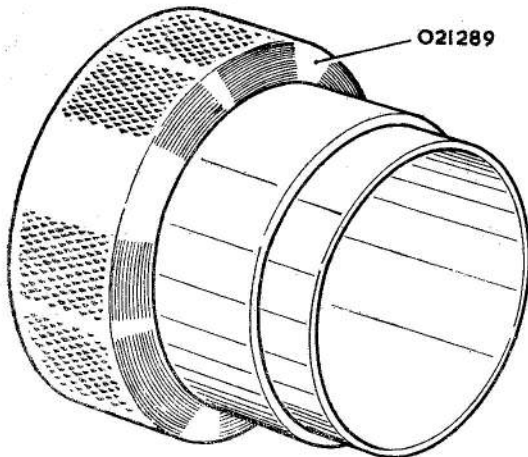

Fig. 7. Impeller/suction cover clearance gauge

34. Use special tool 021289 (fig. 7) to gauge clearance between impeller (9) and slipping. Fit the suction baffle (4) with five screws (2) and lockwashers (3). The suction cover (1) is then fitted and held in place by three clips (19), screws (17) and lockwashers (18).

35. If by-pass valve has been dismantled, use suitably sized snap head soft aluminium rivets when reassembling.

36. Lift clamp (72) and place suppressors (73) in position. Fasten by securing to seat (77) under bracket (74) with two screws (70) and spring lockwashers (71). Assemble each of the three resistances by inserting bolt (58) through top disc (62), sleeve (63), resistances (64), bottom disc (62) and locknut (68). Each resistance is made up of a small washer (60), washer (61), disc, on each end of a sleeve and resistance, all of which are held together by bolt (59) and locknut (68). Ensure that screws (67) are tight before placing assembled resistances in position.

37. Loosen nut (68) to allow bolt head to slip over top bracket (74) and nut to fit under bottom bracket (65). When resistances have been placed in correct position, tighten locknut (68).

38. Replace wiring to the three resistances (64) and three suppressors (73) (fig. 8). After resoldering connections and ensuring contacts are sound, push sleeves back in position.

39. Re-assemble joint (35) and cover plate (36) by replacing twenty-one screws (39), lockwashers (38) and plain washers (37). Before replacing access plate (42) ensure that the ten cross wire thread inserts (40) are in position.

40. Replace joint (41), and access plate, by inserting the ten screws (44) and lockwashers (43).

## TESTING

### General

41. After final assembly the pump unit complete is now ready for testing for operational service.

### Running light test

42. Run the motor light to ensure that the brushes are bedded over 80 per cent of their axial width and their whole circumferential thickness

- (1) Motor to be fitted with open ended canister to act as a cooling cowl.
- (2) Run the motor at 9000 rev/min., this speed to be obtained by an external regulating resistance in the shunt circuit.
- (3) Brush polarity to be changed every two hours during bedding to prevent excessive brush wear.

### Overspeed test.

43. Run the motor light at 15,000 rev/min. for ten minutes. During this run there must be no signs of excessive noise or vibration.

### Continuity resistance test

44. Measure the resistance of the armature and field windings, corrected to 15 deg. C. The values must be within the following limits:

- (1) Armature 180 deg. apart  
0.154 to 0.162 ohms
- (2) Field windings (per coil)  
Series 0.018 to 0.022 ohms  
Shunt 3.33 to 4.00 ohms

**RESTRICTED**

**Performance test**

45. The rotation of the shaft looking at the commutator end shall be clockwise. The motor speed when coupled to a suitable brake and run at a torque of 23 oz. in. on a terminal voltage of 26 volt d.c. must not be less than 5900 rev/min., and not more than 6100 rev/min. The motor speed, when coupled to a suitable brake and run at a torque of 26 oz. in. on a terminal voltage of 28 volt d.c. must not exceed 6,900 rev/min. The current consumption must not exceed 13.5 amperes.

**High voltage test**

46. The insulation resistance of the motor must withstand a test pressure of 500 volt (r.m.s.) 50 cycles a.c., applied between live parts and the frame for a period of one minute

**Insulation resistance test**

47. The insulation resistance between live parts and the frame must not be less than 2 megohms, when measured at a test potential of 250 volt d.c. These measurements are to be made with the motor hot.

**Rating of motor and speed control.**

48. The rating is continuous with maximum voltage at high altitude fast speed. Fifteen minute rating, with maximum voltage at low altitude fast speed. The speed control, due to shunt field variation is two medium speeds, two fast speeds and one slow speed.

**Refuelling requirements**

49. It must be possible to refuel the tank directly through the pump at a maximum rate of 30 gallons per minute with a pressure of 10 lb/in<sup>2</sup>. The suction by-pass valve should be made to open during refuelling operations to prevent the motor rotating. Aviation fuels used may be Avcat, Avtag, or Avtur.

**Starting test.**

50. The assembled pump shall start satisfactorily when 16 volt d.c. is applied. For this test the pump shall be fully primed and completely submerged. The test shall be at low altitude fast speed. A suitable test rig is shown fig. 9.

**Dry running test.**

51. The pump shall be mounted clear of the fuel and run dry for not less than 5 minutes with 28 volt d.c. applied at low altitude fast speed. The current during this test shall be observed and should not exceed 7.5 amperes.

**Gland leakage tests**

52. The pump is to be fully primed under one foot head of fuel, over which a superimposed air pressure of 16 lb/in<sup>2</sup> is to be applied. Observations are to be made for

- (1) External leakage of fuel
- (2) Internal leakage of fuel
- (3) Gland leakage of fuel

The allowable rate of leakage past the gland is 1 c.c. per hour. No other leakage is permissible.

**Calibration test**

53. The no delivery pressure at the pump outlet, including the corresponding fuel tank pressure of the aircraft for which the pump has been designed shall not exceed 30 lb/in<sup>2</sup> when running on the maximum voltage at low altitude fast speed.

54. At all five speeds the pump is to be run under a fuel head of 6 inches above the pump inlet for 30 minutes at low altitude fast speed with 26 volt d.c. supply at a delivery pressure of 11 lb/in<sup>2</sup>. ◀ Switch to high altitude fast speed and run for a further period of 15 minutes. ▶ Flow rate 300 gallons per hour. Calibrate by adjustment of resistance assemblies given in Table 3.

~~RESTRICTED~~

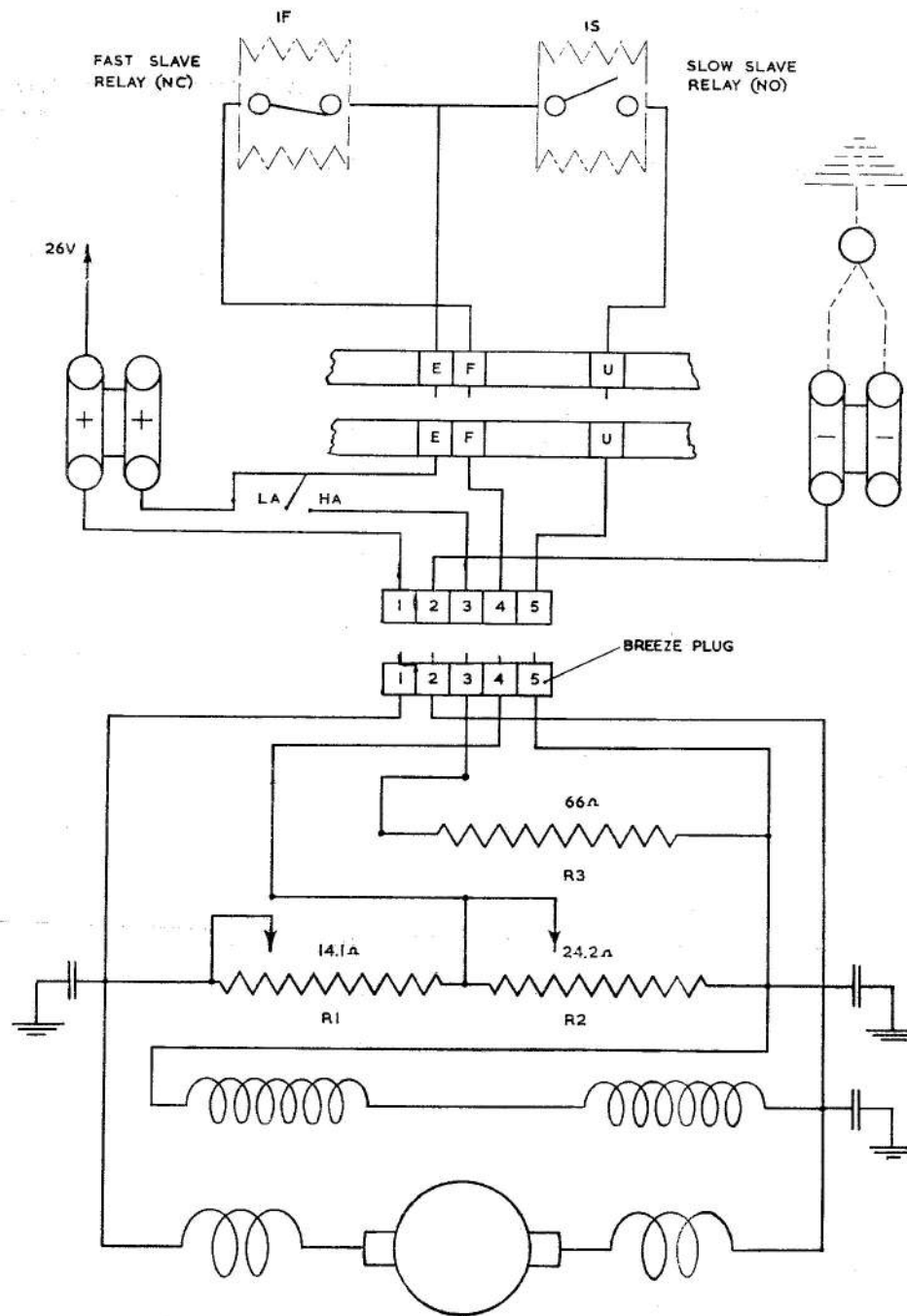

TABLE OF SHUNT FIELD AND SHUNT-REGULATOR DATA

CONDITION		FIELD A	TOTAL A	FIELD W	REG'R W	TOTAL W
LOW ALT.	SLOW	2.05		53.3	0	53.3
	MEDIUM	0.705		6.3	12.0	18.3
	FAST	0.510		3.3	10.0	13.3
HIGH ALT.	SLOW	2.05		53.3	0	53.3
	MEDIUM	0.86		9.4	13.1	22.5
	FAST	0.705		6.3	12.0	18.3

R1. 34 $\Omega$  RESISTANCE - MAX CURRENT - 1.15 AMPS - 45 WATTS RATING.  
 R2. 34 $\Omega$  RESISTANCE - MAX CURRENT - 1.15 AMPS - 45 WATTS RATING.  
 R3. 107 $\Omega$  RESISTANCE - MAX CURRENT - 0.65 AMPS - 45 WATTS RATING.

Fig. 8. Circuit diagram  
~~RESTRICTED~~

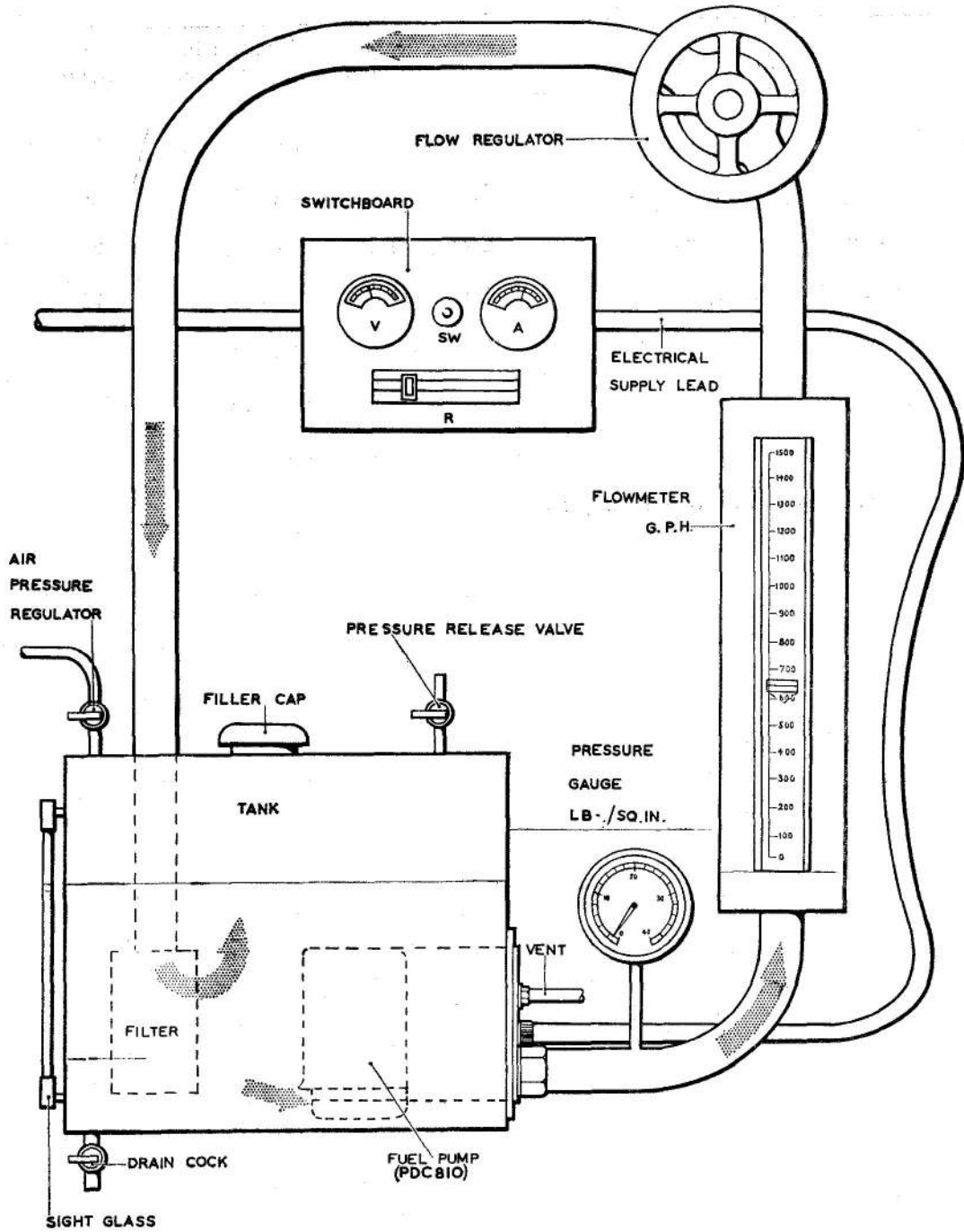

Fig. 9. Test rig

**RESTRICTED**

**TABLE 3****Calibration test figures**

Speed class	Fuel flow in gallons per hour	Pressure in lb. per sq. in.	d.c. voltage
Low altitude medium speed	900	Not less than 10.5	26
Low altitude medium speed	Closed valve	16 to 17	26
Low altitude fast speed	Closed valve	18.5 to 20	26
High altitude fast speed	Closed valve	17 to 18	26
High altitude medium speed	Closed valve	15 to 16	26
Slow speed	Closed valve	9 to 13.5	26

The maximum current is 16 amperes.

**RESTRICTED**

TABLE 4

Schedule of Parts—PDC 810 Tank Fuel Pump.

Item No.	Description	Makers Part No.	Mk.	No. off per pump
1	Strainer, suction ... ..	09921	2-6	1
2	Screws, 4 BA. cheese head $\times \frac{3}{16}$ " long	BSS A31/B6	2-6	5
3	Lockwashers, 4 BA. Internal Type... ..	Shakeproof	2-6	5
4	Baffle, suction ... ..	09920	2-6	1
5	Screws, ... ..	03901	2-6	5
6	Slipring, ... ..	09919	2-6	1
7	Cover, suction, ... ..	09918	2-6	1
8	Joint, suction cover to casing ... ..	09942	2-6	1
9	Impeller, ... ..	09922	2-6	1
10	Washer, $\frac{1}{4}$ " plain... ..	BSS. SP10/E	2-6	1
11	Lockwasher, $\frac{1}{4}$ " Double spring ... ..	BSS. SP55/E	2-6	1
12	Ring, carbon ... ..	99269	2-6	1
13	Gland, metal bellows ... ..	99267	2-6	1
14	Screws, drive ... ..	F/11788	3-6	2
15	Nameplate, ... ..	015701	3-6	1
16	Pump casing, ... ..	015394	2-6	1
17	Screws, 4 BA. cheese head $\times \frac{3}{16}$ " long	BSS. A31/B10	2-6	3
18	Lockwashers, 4 BA. internal type ... ..	Shakeproof	2-6	3
19	Clips, strainer ... ..	11741	2-6	3
20	By-pass valve assembly (items 21-32 incl) ...	015674		
21	Screws, 4 BA. c'sk. head $\times \frac{1}{4}$ " long ...	BSS. A33/B8	2-6	4
22	Lockwashers, 4 BA. c'sk. internal type ...	Shakeproof	2-6	4
23	Seat, ... ..	015667	2-6	1
24	Joint, seat ... ..	018920	3-6	1

F.S./9

~~RESTRICTED~~

TABLE 4—contd.

## Schedule of Parts—PDC 810 Tank Fuel Pump.

Item No.	Description	Makers Part No.	Mk.	No. off per pump
25	Plate, cover ... ..	015671	2—6	1
26	Joint, ... ..	015672 Iss. 1	2—3	1
27	Joint, ... ..	015672 Iss. 3	4—6	1
28	Hinge seat, ... ..	015668	2—6	1
29	Flap, by-pass valve ... ..	015669	2—6	1
30	Hinge, flap ... ..	015670	2—6	1
31	Spring, ... ..	015673	2—6	1
32	Pin, hinge, ... ..	015353	2—6	1
33	Modification plate, ... ..	021243	4	1
34	Screws, drive, ... ..	F/11788	4	2
35	Joint, cover plate ... ..	015647	2—6	1
36	Plate, cover ... ..	015375	2—6	1
37	Washers, 2 BA. 26 SWG. plain ...	BSS.SP10/C	2—6	21
38	Lockwashers, 2 BA. spring ... ..	BSS. SP47/C	2—6	21
39	Screws, 2 BA. cheese head $\times \frac{5}{8}$ " long	BSS. A31/C20	2—6	21
40	Cross wire thread inserts. $\frac{5}{16}$ " ... ..	2 BA.	2—6	10
41	Joint, access plate ... ..	015387	2—6	1
42	Plate, access ... ..	015386	2—6	1
43	Lockwashers, 4 BA. countersunk ... ..	Shakeproof	2—6	10
44	Screws, 4 BA. c'sk head ... ..	BSS. A33/B12	2—6	10
45	Joint, electrical connection seal ... ..	015390	2—6	1
46	Joint, motor to casing ... ..	015495	2	2
47	Joint, motor to casing ... ..	015495	3—6	1
48	Canister, bottom, ... ..	015388	2—6	1
49	Joint, motor to casing ... ..	118/6 Mk. 18	2—6	1

~~RESTRICTED~~

TABLE 4—contd.

Schedule of Parts—PDC 810 Tank Fuel Pump.

Item No.	Description	Makers Part No.	Mk.	No. off per pump
50	Lockwashers, 2 BA. internal type ... ..	Shakeproof	2—6	12
51	Screws, motor ... ..	015355	2—6	9
52	Screws, long motor ... ..	015613	2—6	3
53	Distance piece, ... ..	015356	2—6	3
54	Lockwashers, 2 BA. internal type ... ..	Shakeproof	2—6	3
55	Nuts, (Simmonds) nyloc hexagon, thin 2 BA.	AGS 2002/C/1	2—6	3
56	Canister, top ... ..	015385	2—6	1
57	Resistance assembly (items 58—68 incl.) ...			
58	Bolt, ... ..	12656 Mk. F.	2	3
59	Bolt, ... ..	12656 Mk. H.	3—6	3
60	Washer, small, ... ..	015745	3—6	6
61	Washer, ... ..	015744	3—6	6
62	Disc, top or bottom ... ..	015395	2—6	6
63	Sleeve, ... ..	015396	2—6	3
64	Resistances (2—64 ohms; 1—140 ohms) ...	BERCO V. Mk. 8	2—6	3
65	Brackets, ... ..	015392	2—6	6
66	Lockwashers, 4 BA. internal type ... ..	Shakeproof	2—6	6
67	Screws, 4 BA. cheese head $\times \frac{3}{16}$ " long	BSS. A31/B10	2—6	6
68	Nuts, (Simmonds) nyloc hexagon, thin 4 BA.	AGS 2002/B/1	2—6	3
69	Suppressor assembly (items 70—80 incl.) ...	015666		
70	Screws, 4 BA. cheese head $\times \frac{3}{16}$ " long	BSS.A31/B20	2—6	2
71	Lockwashers, 4 BA. spring ... ..	BSS. SP47/B	2—6	2
72	Clamp, ... ..	015391	2—6	1

TABLE 4—contd.

## Schedule of Parts—PDC 810 Tank Fuel Pump.

Item No.	Description	Makers Part No.	Mk.	No. off per pump
73	Suppressors, (0.75U/F) ... ..	AM Stores Ref. 5C/3602	2-6	3
74	Bracket, ... ..	015393	2-6	1
75	Lockwashers, 4 BA. internal type ... ..	Shakeproof	2-6	2
76	Screws, 4 BA. cheese head $\times \frac{5}{16}$ " long	BSS. A31/B10	2-6	2
77	Seat, ... ..	015664	2-6	1
78	Bracket, lead, ... ..	015665	2-6	1
79	Lockwashers, 4 BA. ... ..	Shakeproof	2-6	2
80	Screws, ... ..	015679 Mk. A	2-6	2
81	Nut, ... ..	Z/8354/6	2-6	1
82	Lockwashers, (Barber & Coleman, type 12) $\frac{5}{16}$ " I/D.	Shakeproof	2-6	1
83	Screws, 6 BA. c'sk. hd. $\times \frac{1}{2}$ " long ...	BSS. A33/A16	2-5	3
84	Lockwasher, (Barber & Coleman, type 15) 6 BA.	Shakeproof	2-6	3
85	Thrower, fuel ... ..	Z/8354/5	2-6	1
86	Plate, grease, drive end outer ... ..	Z/8354/7	2-6	1
87	Bearing, double shielded, drive end (Hoffman)	N.6005. 2 Dot	6	1
88	Bearing (Hoffman S.5) ... ..	SKF.E.E4Y	2-5	1
89	Grommet, (Cow)... ..	Type G8C	2-6	1
90	Stator Housing ... ..	W/8354/1	2-6	1
91	Plate, grease, drive end inner ... ..	Z/8354/8	2-6	1
92	Studs, ... ..	Z/8354/17 Iss. 3	2-6	2
93	Pin, shaft, ... ..	018951	2-6	1
94	Field coil assembly ... ..	W/8354/1/2	2-6	1
95	Armature assembly, ... ..	X/8354/1/1	2-6	1

~~RESTRICTED~~

TABLE 4—contd.

Schedule of Parts—PDC 810 Tank Fuel Pump.

Item No.	Description	Makers Part No.	Mk.	No. off per pump
96	Lockwashers, (Barber & Coleman, type 12) 4 BA.	Shakeproof	2—6	4
97	Screws, field stack fixing ... ..	Z/8354/26	2—6	4
98	Plate, grease, non drive end inner. ... ..	Z/8354/9	2—6	1
99	Bracket, bearing, ... ..	X/8354/2	2—6	1
100	Lockwashers, (Barber & Coleman type 12) 4 B.A.	Shakeproof	2—6	2
101	Nuts, hex. 4 BA. ... ..	Standard	2—6	2
102	Studs ... ..	Z/8354/17 Iss. 2	2—6	2
103	Lockwashers, (Barber & Coleman, type 12) 4 BA.	Shakeproof	2—6	2
104	Nuts, hex. 4 BA. ... ..	Standard	2—6	2
105	Lockwashers, (Barber & Coleman, type 15) 6 BA.	Shakeproof	2—6	3
106	Screws, 6 BA. c'sk head $\times \frac{1}{2}$ " long ... ..	BSS. A33/A16	2—6	3
107	Ring, clamping ... ..	Z/8354/14	2—6	1
108	Motor cover plate ... ..	Y/8354/30	2—6	1
109	Gasket, ... ..	Z/8354/29	2—6	1
110	Plate, grease, non drive end outer. ... ..	Z/8354/10	2—6	1
111	Bearing, Commutator end (Hoffman, S.3) ...	SKF.E.E3Y	2—6	1
112	Brush assembly, (items 111—117 incl.) ...	Y/8354/23		
113	Screws, brush box, 4 BA. cheese hd. $\times \frac{3}{4}$ " long	BSS. A31/B24	2—6	4
114	Lockwasher, (Barber & Coleman, type 12) 4 BA.	Shakeproof	2—6	4
115	Rocker, brush ... ..	Z/8354/22	2—6	1
116	Screw, 4 BA., cheese head $\times \frac{1}{4}$ " long ...	BSS. A31/B8	2—6	2

F.S./11

**RESTRICTED**

TABLE 4—contd.

Schedule of Parts—PDC 810 Tank Fuel Pump.

Item No.	Description	Makers Part No.	Mk.	No. off per pump
117	Washer, 4 BA., 22 SWG plain ... ..	BSS. SP25/B	2—6	2
118	Brush, carbon (Morgan Crucible) ... ..	Z/8354/24	2—6	2
119	Holder, brush ... ..	105/361 Group 1	2—6	2
120	Solder Tag. 4 BA. ... ..	RC.470	2—6	2

~~RESTRICTED~~

999/225 W/L 62523/D 4750 1.750 13/5/60 M.C.C.

F.S./12

**RESTRICTED**

**APPENDIX 1**

**Schedule of fits, clearances and repair tolerances**

All dimensions in inches

Pump, fuel, PDC 810 Mk. 2, 3, 4, 5 and 6

Item (1)	Description (2)	New Dimension (3)	Permissible worn dimension (4)	New clearance (5)	Permissible worn clearance (6)	Remarks (7)
1	BRUSH LENGTH	Long	.750	—	—	Brush shortens approx- imately .055 in 500 hours
		Short	.625			
2	COMMUTATOR	diameter	1.640	1.59	—	Diameter reduces approx- imately .001 in 500 hours
			1.610			
3	ARMATURE END FLOAT	—	—	—	.005	
4	ARMATURE SHAFT IN DRIVE END BALL RACE	.5000	—	—	—	—
		.4998				
5	ARMATURE SHAFT IN COMMUTATOR END BALL RACE	.3750	—	—	—	—
		.3748				
6	IMPELLER DIAMETER	1.6125	1.6075	.0125	.020	Should not be worn by contact but may be scratched by abrasives in pumped fuel. Minimum radial clearance (allow- ing for impeller eccen- tricity) should not be less than .003.
		1.6115				
	1.6260	1.6275				
	1.6250					
7	IMPELLER	carbon ring	.151	.133	—	Slight scoring can be re- moved by lapping, but final thickness must not be less than that stated.
			.161			

A.P. 4343D, Vol. 6, Sect. 7, Chap. 40, App. 1  
A1.81, Jan. 60

12/15/84

( )

( )

( )

( )

12/15/84

12/15/84

This file was downloaded  
from the RTFM Library.

Link: [www.scottbouch.com/rtfm](http://www.scottbouch.com/rtfm)

Please see site for usage terms,  
and more aircraft documents.

