

Chapter 41

PUMP, FUEL, PDC.2400 DE SERIES

LIST OF CONTENTS

	Para.		Para.
Introduction ... ..	1	Assembling the frame unit and arma- ture ... ..	30
<b>Reconditioning</b>		Assembling the commutator-end cast- ing unit, the frame unit and the arma- ture sub-assembly (fig. 20) ... ..	31
Tools and test equipment ... ..	3	Checking the frame unit/motor unit shaft concentricity ... ..	32
<b>Dismantling</b>		Brush-bedding motor run ... ..	33
General ... ..	4	Motor torque test ... ..	34
Removing the canister and bottom suc- tion strainer ... ..	5	Insulation resistance test ... ..	35
Dismantling the suppressor box assem- bly ... ..	6	<b>Pump unit</b>	
Removing the delivery pipe ... ..	7	Concentricity check on assembled motor shaft ... ..	36
Removing the top suction strainer and vapour deflector ... ..	8	Assembling the top casing ... ..	37
Detaching the mounting plate assembly	9	Assembling the upper propeller ... ..	38
Removing and dismantling the by-pass valve ... ..	10	Assembling the pump casing sub- assembly ... ..	39
Removing the lower bearing housing assembly ... ..	11	Fitting the pump casing to the motor unit ... ..	40
Dismantling the pump casing assembly	12	Assembling the lower pump shaft components ... ..	41
Dismantling the top casing assembly	13	Pressure testing for gland leakage	42
Removing the distance ring and slip ring from the top casing ... ..	14	Assembling the mounting plate ... ..	43
Dismantling the motor unit		Assembling the suppressor box ... ..	44
Removing the brushes ... ..	15	Assembling the delivery pipe ... ..	45
Removing the commutator-end cast- ing ... ..	16	Assembling the suppression unit and electrical connection ... ..	46
Withdrawing the armature shaft as- sembly ... ..	17	Re-assembling and fitting the by-pass valve assembly ... ..	47
Removing the drive-end bearing ... ..	18	Completing the assembly ... ..	48
Dismantling the commutator-end cas- ing sub-assembly ... ..	19	<b>Testing</b>	
Frame unit ... ..	20	General ... ..	49
<b>Cleaning, examination and repair</b>		Test equipment ... ..	50
Cleaning ... ..	21	<b>Schedule of tests</b>	
<b>Examination</b>		Insulation resistance test ... ..	51
General ... ..	24	Gland leakage test ... ..	52
Detailed procedure ... ..	25	Starting test ... ..	53
Lapping rotary and stationary seal faces ... ..	26	Endurance test ... ..	54
<b>Assembling</b>		Calibration test ... ..	56
General ... ..	27	Dry test ... ..	57
<b>Motor unit</b>		Final insulation resistance test ... ..	59
Re-assembling the commutator-end casting unit ... ..	28	Wire locking ... ..	60

~~RESTRICTED~~

## LIST OF TABLES

	Table
<i>Special tools and equipment</i> ... ..	1
<i>Detailed inspection of components</i> ... ..	2
<i>Schedule of fits, clearances and repair tolerances</i> ... ..	3

## LIST OF ILLUSTRATIONS

	Fig.		Fig.
<i>Part sectional view of the pump assembly</i> ... ..	1	<i>Tools for separating the slip ring and distance sleeve</i> ... ..	17
<i>Gland drain and motor lead tube assemblies</i> ... ..	2	<i>Sectional view of the motor unit assembly</i> ... ..	18
<i>Sectional view of the suppressor box assembly</i> ... ..	3	<i>Fixture for assembling the drive-end bearing into the frame unit</i> ... ..	19
<i>Exploded view of pump unit (upper end)</i> ... ..	4	<i>Exploded view of motor unit assembly</i> ... ..	20
<i>Tool for withdrawing the lower rotary seal ring</i> ... ..	5	<i>Exploded view of commutator-end unit</i> ... ..	21
<i>Tool for withdrawing the spacing bush</i> ... ..	6	<i>Fixture for assembling the armature, and the commutator-end units on to the frame unit assembly</i> ... ..	22
<i>Exploded view of pump unit (lower end)</i> ... ..	7	<i>Tools for assembling the upper rotary seal and slinger</i> ... ..	23
<i>Extractor for commutator-end casting unit</i> ... ..	8	<i>Tools for assembling the top casing slip-ring and distance sleeve</i> ... ..	24
<i>Extractor plates for removing the commutator-end bearing</i> ... ..	9	<i>View on the end of the shaft showing the impeller vanes</i> ... ..	25
<i>Exploded view of suppressor box assembly</i> ... ..	10	<i>Tools for assembling the slip-ring/distance sleeve sub-assembly to the top casting</i> ... ..	26
<i>Exploded view of upper and lower gland housing assemblies</i> ... ..	11	<i>Tools for assembling the upper gland housing to the top casing</i> ... ..	27
<i>Tools for removing the lower gland housing</i> ... ..	12	<i>Gland leakage pressure test tools</i> ... ..	28
<i>Tools for removing the upper impeller slip-ring from the pump casting</i> ... ..	13	<i>Tools for assembling the lower gland housing to the pump casing</i> ... ..	29
<i>Tools for removing the top casing gland housing</i> ... ..	14	<i>Tools for assembling the upper impeller slip-ring into the pump casing</i> ... ..	30
<i>Tools for dismantling the upper rotary seal/slinger sub-assembly</i> ... ..	15	<i>Tools for pressure testing the suppressor box/mounting plate joint</i> ... ..	31
<i>Tools for removing the slip-ring/distance sleeve sub-assembly from the top casing</i> ... ..	16	<i>Alignment of the suppressor box and the delivery tube</i> ... ..	32

## LIST OF APPENDICES

	App.
<i>Reconditioning PDC.2400 DE. Mk. 1 and 2 fuel pumps</i> ... ..	1
<i>Reconditioning PDC.2400 DE. Mk. 3 fuel pumps</i> ... ..	2

~~RESTRICTED~~

**Introduction**

1. Re-conditioning instructions are given in this chapter for the PDC.2400 DE.Mk.4 pumps, with appendices covering the differences in procedure for the earlier and later pumps in the series. A general description of the type PDC.2400 DE. series fuel pump is given in A.P.4343D, Vol. 1, Sect. 7, Chap. 4 and details of the variations between the different mark numbers are given in the appendices to the chapter.

2. The pump assembly comprises a compound-wound four pole d.c. motor unit driving first stage propellers at each end of the

extended armature shaft. These pressurize the canister and feed the fuel to a second stage double-entry impeller which delivers the fuel under pressure into the aircraft fuel system.

**RECONDITIONING****Tools and test equipment**

3. In addition to the standard bench tools, the special tools listed in Table 1 are required to overhaul the PDC.2400 DE. series pumps. Details of the Universal fuel pump test rig which should be used to test these pumps is contained in A.P.4343S, Vol. 1, Book 2, Sect. 10

**TABLE 1****Special tools and equipment**

Nomenclature		Part No.	Fig. No.	Ref. No.
Locating base		SPE.17632	12,14,27,29	
Pump casting support	Upper and lower gland housing removal	SPE.17633	12,14	
Drift		SPE.17634		
Drift locator		SPE.17635		
Slip-ring drift	Removing impeller slip-ring from pump casing	SPE.17636	13,30	
Slip-ring locating bush		SPE.17637		
Slip-ring drift plate		SPE.17638		
Support block		SPE.17639		
Casting locating bush		SPE.17640		
Extractor—lower rotary seal ring		SPE.17641	5	
Extractor—spacing bush		SPE.17642	6	
Top casing support block—upper gland housing removal		SPE.17643	14	
Base and pillar assembly	Dismantling and assembling rotary seal/slinger sub-assy.	SPE.17644	15,23	
Punch		SPE.17646		
Register		SPE.17647		
Drift		SPE.17648		
Pillar	Sleeve and slip-ring sub-assy. removal	SPE.17649	16,26	
Top-casing locating base		SPE.17650		
Location bush		SPE.17651		
Sleeve and slip-ring support plate		SPE.17652	17,24	
Base and pillar	Separation and assembly of distance sleeve and slip-ring	SPE.17653		
Sleeve support		SPE.17654		
Upper slip-ring drift		SPE.17655		
Extractor—commutator-end casting unit		CX.169943	8	
Extractor plates (2 off per set)		CX.134368	9	
Base	Assembling drive-end bearing into frame unit	CX.169944-1	19	
Location post		CX.169944-2		
Pressing sleeve		CX.169944-3		

**RESTRICTED**

TABLE 1—(contd.)

Special tools and equipment—(contd.)

Nomenclature	Part No.	Fig. No.	Ref. No.
Base	CX.169945-1	22	
Guide	CX.169945-2		
Post (2 off)	CX.169945-3		
Pressing sleeve	CX.169945-4		
Support block	CX.169945-5		
Sleeve (2 off)	CX.169945-6		
Sleeve location bush	SPE.17656	24	
Location bush	SPE.17657	26	
Pillar	SPE.17658		
Upper slip-ring sub-assembly drift	SPE.17659		
Gland support block	SPE.17660	27,29	
Drift	SPE.17661		
Gland support block—gland housing to pump casing	SPE.17662	29	
Pump casing/slip-ring support block	SPE.17663	30	
Pump casing drift	SPE.17664		
Blanking plate	SPE.17665	28	
Gasket	SPE.17666		
Blanking plate	SPE.17667	31	
Gasket	SPE.17668		
Cover blanking plate	SPE.17669		
Gasket	SPE.17670		
Stroboflash			6C/610

**RESTRICTED**

**DISMANTLING****Notes . . .**

(1) *The numbers in brackets in the text refer to the illustration quoted following the paragraph heading unless otherwise indicated.*

(2) *Ascertain whether the pump has been returned with a history sheet or any other documents which will highlight the points needing particular attention.*

(3) *The complete dismantling of the pump and motor unit is detailed in this chapter, but the dismantling of individual sub-assemblies should be determined by examination and in the light of the information on the pump life and faults etc. supplied with each returned pump.*

**General**

4. Cut the locking wire to all external seals.

**Removing the canister and bottom suction strainer (fig. 1)**

5. (1) Remove the four screws (35), spring washers (36) and plain washers (37) securing the canister (57) to the top casing sub-assembly (55).

(2) Withdraw the seal ring (52) from the rim seating of the top casing and discard.

(3) Withdraw the seal ring (71) from the groove in the pump casing assembly (61) and discard.

(4) Shape the bottom suction strainer (74) to a circular form and withdraw it over the pump casing.

**Dismantling the suppressor box assembly**

6. (1) *Refer to Fig. 1.* Remove the four cheese-head screws (88), spring washers (89) and plain washer (90) securing the suppressor box cover (85) and joint washer (86) to the suppressor box (87). Discard the joint washer.

(2) *Refer to Fig. 10.* Remove the screw (132), spring washer (133) and plain washer (134) securing the suppressor clamp (131).

(3) Disconnect the motor unit leads and electrical connection lead assemblies (130, 136, and 148) from the capacitors (147) and resistor (143).

**Note . . .**

*To facilitate re-assembly, replace all suppression unit terminal fittings on the unit after removing the leads.*

(4) Slacken the nut (144) and lift the resistor (143) from the cradling lugs of the suppressor box. Remove the nut and shake-proof washer (138), withdraw the bolt (137), washers (140) and further shakeproof washer (138) and extract the resistor centre (139).

(5) *Refer to Fig. 7.* Remove the nuts (149), and shakeproof washers (150) together with the screws (152) and shakeproof washers (151) securing the electrical plug (91) to the suppressor box. The electrical connection leads (130, and 148: Fig. 10) need only be detached from the plug pins if either the pins or leads are damaged.

(6) Detach the suppressor box (87), from the mounting plate assembly (1) by removing the four screws (106) and seal washers (107).

**RESTRICTED**

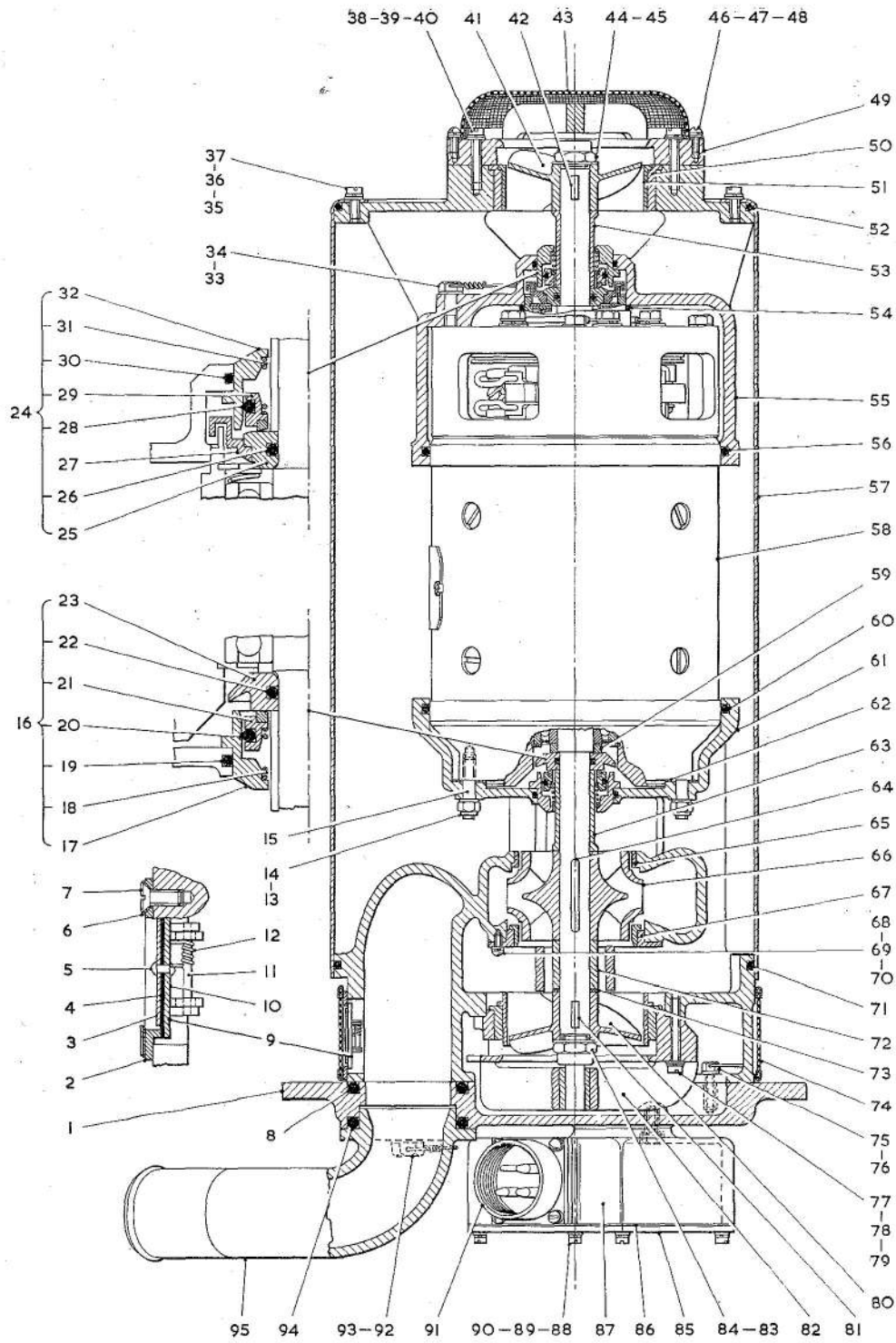

Fig. 1. Part sectional view of the pump assembly

**RESTRICTED**

## Key to Fig. 1

1	MOUNTING PLATE & INSERTS ASSY	
2	BY-PASS VALVE SEAT	
3	BY-PASS VALVE COVER PLATE	
4	BY-PASS VALVE FACE	
5	BY-PASS VALVE RIVET	
6	CSK. LOCKWASHER	} BY-PASS VALVE
7	CSK. HD. SCREW	
8	MOUNTING PLATE/PUMP CASING 'O' RING	
9	BY-PASS VALVE ASSY	
10	BY-PASS VALVE FLAP	
11	BY-PASS VALVE HINGE PIN	
12	BY-PASS VALVE SPRING	
13	SELF-LOCKING NUT	} MOTOR UNIT
14	BONDED SEAL WASHER	
16	LOWER FLEXIBOX SEAL COMPLETE	
17	GLAND HOUSING	} ITEM 16
18	SPRING	
19	GLAND HOUSING 'O' RING	
20	STATIONARY SEAL 'O' RING	
21	STATIONARY SEAL	
22	ROTARY SEAL 'O' RING	} ITEM 24
23	ROTARY SEAL	
24	UPPER FLEXIBOX SEAL COMPLETE	
25	ROTARY SEAL	} MOTOR UNIT
26	ROTARY SEAL 'O' RING	
27	SLINGER	
28	STATIONARY SEAL 'O' RING	
29	STATIONARY SEAL	
30	GLAND HOUSING 'O' RING	} CANISTER
31	SPRING	
32	GLAND HOUSING	} VAPOUR
33	HEX. HD. SCREW	
34	BONDED SEAL WASHER	} SECURING
35	CH. HD. SCREW	
36	SPRING WASHER	} SECURING
37	PLAIN WASHER	
38	CH. HD. SCREW	} DEFLECTOR
39	SPRING WASHER	
40	PLAIN WASHER	
41	TOP PROPELLER	
42	WOODRUFF KEY	
43	TOP SUCTION STRAINER	
44	SELF LOCKING NUT	} TOP PROPELLER
45	PLAIN WASHER	
46	ROUND HD. SCREW	} TOP SUCTION
47	SPRING WASHER	
48	PLAIN WASHER	} SECURING
49	VAPOUR DEFLECTOR	
50	TOP PROPELLER DISTANCE SLEEVE	
51	SLIP-RING	
52	TOP CASING/CANISTER 'O' RING	
53	TOP PROPELLER DISTANCE SLEEVE	
54	1.75" DIA TOP CASING/MOTOR UNIT 'O' RING	
55	TOP CASING SUB-ASSY.	
56	5" DIA. TOP CASING/MOTOR UNIT 'O' RING	
57	CANISTER	
58	MOTOR UNIT	
59	SPACING BUSH	
60	5" DIA. PUMP CASING/MOTOR UNIT 'O' RING	
61	PUMP CASING SUB-ASSY.	
62	PAPER GASKET	
63	IMPELLER DISTANCE SLEEVE	
64	FEATHER KEY	
65	IMPELLER SLIP-RING	
66	IMPELLER	
67	BOTTOM BAFFLE & SLIP-RING ASSY.	
68	ROUND HD. SCREW	} BOTTOM BAFFLE
69	SPRING WASHER	
70	PLAIN WASHER	} SECURING
71	PUMP CASING/CANISTER 'O' RING	
72	DISTANCE SLEEVE	
73	SHIM	
74	BOTTOM SUCTION STRAINER	
75	HEX. HD. SCREW	} MOUNTING PLATE
76	PLAIN WASHER	
77	CH. HD. SCREW	} BEARING
78	SPRING WASHER	
79	PLAIN WASHER	} SECURING
80	BOTTOM PROPELLER	
81	BOTTOM PROPELLER WOODRUFF KEY	
82	BEARING HOUSING ASSY.	
83	SELF LOCKING NUT	} BOTTOM
84	PLAIN WASHER	
85	SUPPRESSOR BOX COVER	} SECURING
86	SUPPRESSOR BOX COVER JOINT	
87	SUPPRESSOR BOX	
88	CH. HD. SCREW	} SUPPRESSOR
89	SPRING WASHER	
90	PLAIN WASHER	} COVER SECURING
91	ELECTRICAL CONNECTION	
92	HEX. HD. SCREW	} DELIVERY BEND
93	PLAIN WASHER	
94	DELIVERY PIPE 'O' RING	
95	DELIVERY PIPE	

~~RESTRICTED~~

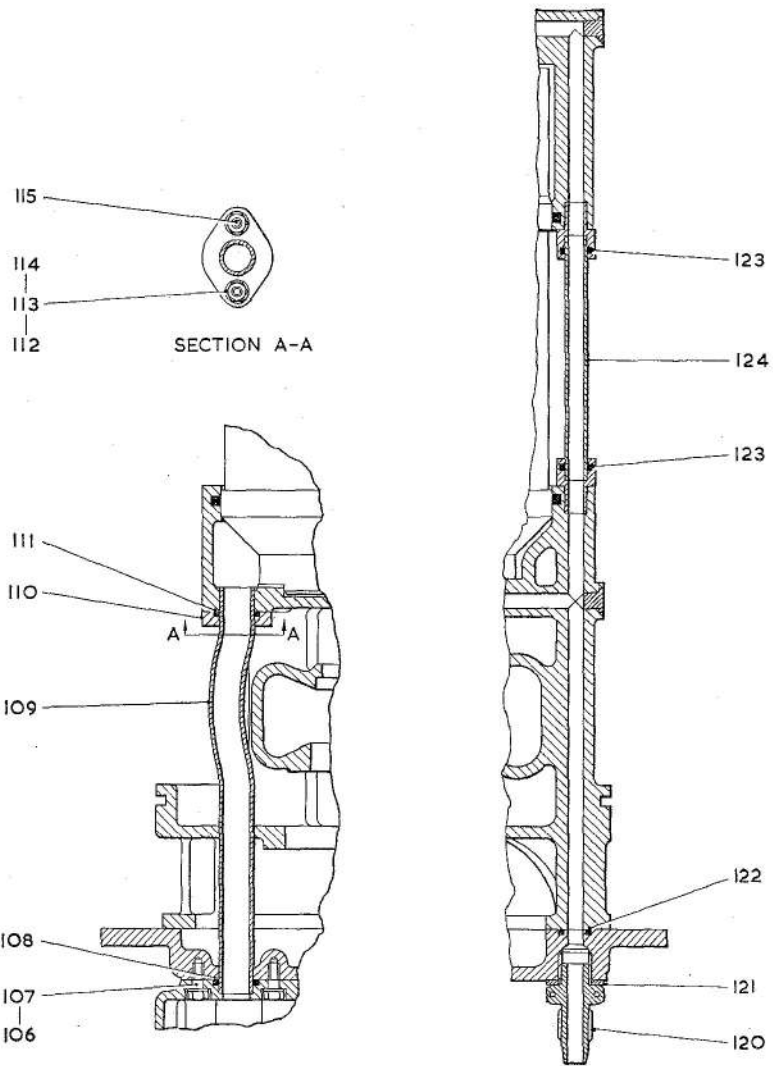

- 106 HEX. HD. SCREW
  - 107 SEAL WASHER
  - 108 'O' RING
  - 109 MOTOR LEAD TUBE
  - 110 CLAMP PLATE
  - 111 'O' RING
  - 112 LOCKNUT
  - 113 SPRING WASHER
  - 114 PLAIN WASHER
- } SUPPRESSOR BOX  
FIXING
- } CLAMP PLATE  
SECURING

- 115 STUD
- 120 GLAND DRAIN CONE ADAPTOR
- 121 SEAL WASHER
- 122 'O' RING (PUMP CASING/MTG. PLATE)
- 123 'O' RING (CASINGS/GLAND DRAIN TUBE)
- 124 GLAND DRAIN TUBE

**Fig. 2. Gland drain and motor lead tube assemblies**

~~RESTRICTED~~

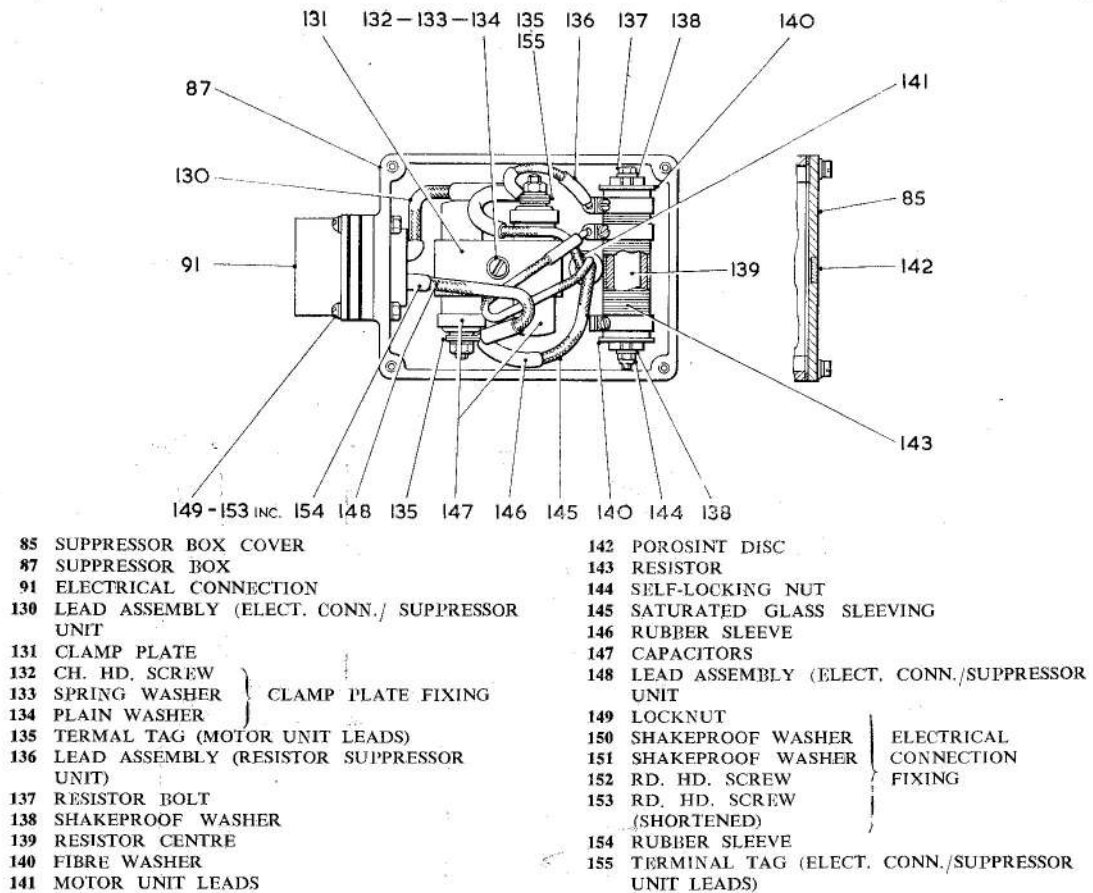

**Fig. 3. Sectional view of the suppressor box assembly**

**Removing the delivery pipe (fig. 1)**

7. (1) Remove the two screws (92) and plain washers (93) securing the delivery pipe (95). Withdraw the latter from the mounting plate and extract the O-ring (94); Discard this seal ring.

**Removing the top suction strainer and vapour deflector (fig. 1)**

8. (1) Remove the four screws (46), spring washers (47) and plain washers (48) securing the top suction strainer (43) to the vapour deflector (49).  
(2) Remove the four screws (38), spring washers (39) and plain washers (40) securing the vapour deflector to the top casing (55).

**Detaching the mounting plate assembly (fig. 1)**

9. (1) Cut the locking wires to the twelve screws (75).

- (2) Remove the screws (75) and plain washers (76) securing the mounting plate assembly (1) to the pump casing sub-assembly (61).

- (3) Extract and discard the seal rings (8).

- (4) Remove the cone adaptor and washer (120 and 121: fig. 2).

**Removing and dismantling the by-pass valve (fig. 1)**

10. (1) Remove the four screws (7) and shakeproof washers (6) securing the valve to the pump casing.

- (2) If it is necessary to dismantle the valve assembly, first file off the peened metal at one end of the hinge pin (11). Withdraw this pin through the hinge to release the spring (12) and the valve plate.

**RESTRICTED**

(3) If the rubber valve disc (4) needs replacement, file the heads off the two rivets (5) and separate the three components of the valve plate assembly. Take care not to damage the surface of the plates when removing the rivet heads as it may result in insecure riveting on re-assembly.

**Removing the lower bearing housing assembly (fig. 1)**

11. (1) Remove the four screws (77), spring washers (78) and plain washers (79) securing the bottom bearing housing (82) to the pump casing (61).

**Note . . .**

*No attempt should be made to remove and replace either the carbon bearings or the distance ring and slip ring sub-assembly. The carbon bearing is a shrink fit in the housing and is reamed after assembly. The bore of the slip ring is also machined after assembly and the bores of both components must be concentric with the bearing housing location spigot within tight limits.*

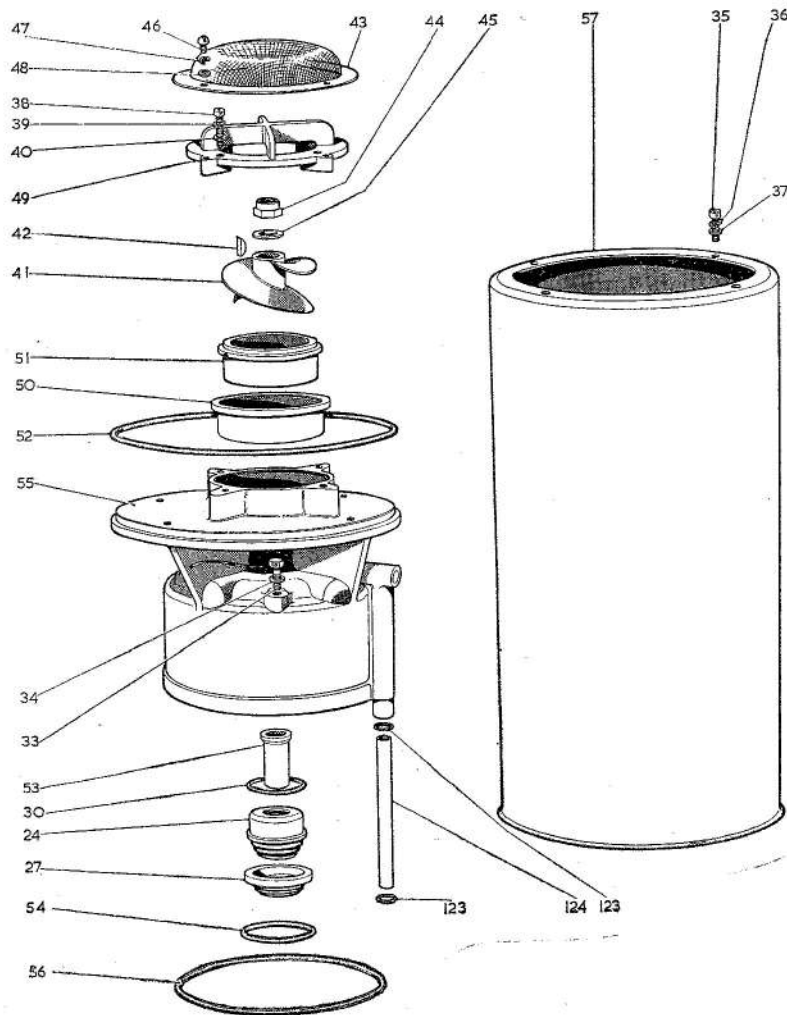

**Fig. 4. Exploded view of pump unit (upper end)**

**RESTRICTED**

## Key to Fig. 4

24	GLAND SUB-ASSEMBLY		
27	SLINGER		
30	'O' RING (GLAND HOUSING)		
33	HEX. HD. SCREW		
34	BONDED SEAL WASHER		
35	CH. HD. SCREW	}	CANISTER
36	SPRING WASHER		
37	PLAIN WASHER	}	SECURING
38	CH. HD. SCREW		
39	SPRING WASHER	}	VAPOUR
40	PLAIN WASHER		
41	TOP PROPELLER	}	DEFLECTOR
42	WOODRUFF KEY		
43	TOP SUCTION STRAINER		
44	SELF-LOCKING NUT	}	TOP PROPELLER
45	PLAIN WASHER		
46	RD. HD. SCREW	}	TOP SUCTION
47	SPRING WASHER		
48	PLAIN WASHER	}	STRAINER
49	VAPOUR DEFLECTOR		
50	DISTANCE SLEEVE		
51	SLIP-RING		
52	TOP CASING/CANISTER 'O' RING		
53	DISTANCE SLEEVE (SHAFT)		
54	TOP CASING/MOTOR UNIT 'O' RING		
55	TOP CASING		
56	5 IN. DIA. TOP CASING/MOTOR UNIT 'O' RING		
57	CANISTER		
123	'O' RING (GLAND DRAIN TUBE)		
124	GLAND DRAIN TUBE		
127	SLINGER AND ROTARY SEAL SUB-ASSEMBLY		

### Dismantling the pump casing assembly (fig. 1)

12. (1) Fit a box spanner with tommy bar over the  $\frac{3}{8}$  in. B.S.F. nut (83), and give a sharp tap with a mallet to release the locknut. Remove the washer (84).
- (2) Withdraw the propeller (80). Remove the stainless steel Woodruff key (81) from the shaft groove, together with any shims (73) fitted.
- (3) Remove the distance sleeve (72).
- (4) Remove the four round-head screws (68), spring washers (69) and plain washers (70) securing the bottom baffle and slip ring assembly to the pump casing (61). Do not attempt to withdraw the slip-ring from the baffle.
- (5) Withdraw the impeller (66) and remove the feather key (64).
- (6) Remove the distance piece (63).
- (7) Remove the four locknuts (13) and seal washers (14) securing the pump casing to the motor unit studs (15). Withdraw the casing. Extract and discard the casing/motor unit seal ring (60) and the paper gasket (62).
- (8) Remove the gland drain tube (124, fig. 4) and its associated seal rings (123).
- (9) Remove the stationary seal (21) and spring (18) from the gland housing (17). Discard the seal ring (20).
- (10) Pre-heat the pump casing to between 125 and 150°C and using the special tools illustrated in Fig. 12 press the gland housing out of its seating.

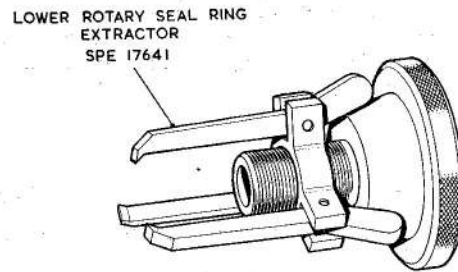
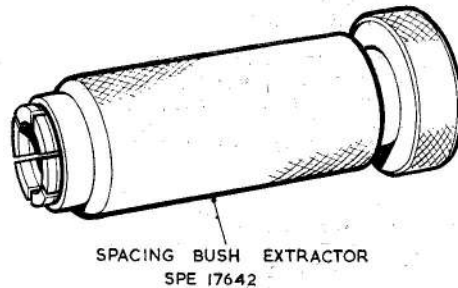

**Fig 5. Tool for withdrawing the lower rotary seal ring**

- (11) While the casting is still warm use the special tools illustrated in Fig. 13 to press the upper impeller slip-ring (65), out of the casting.
- (12) Use the special tool SPE.17641 (fig. 5) to withdraw the rotary seal (23) off the armature shaft. Discard the seal ring (22).

**Note . . .**

*Keep all parts of the dismantled glands together.*



**Fig. 6. Tool for withdrawing the spacing bush**

~~RESTRICTED~~



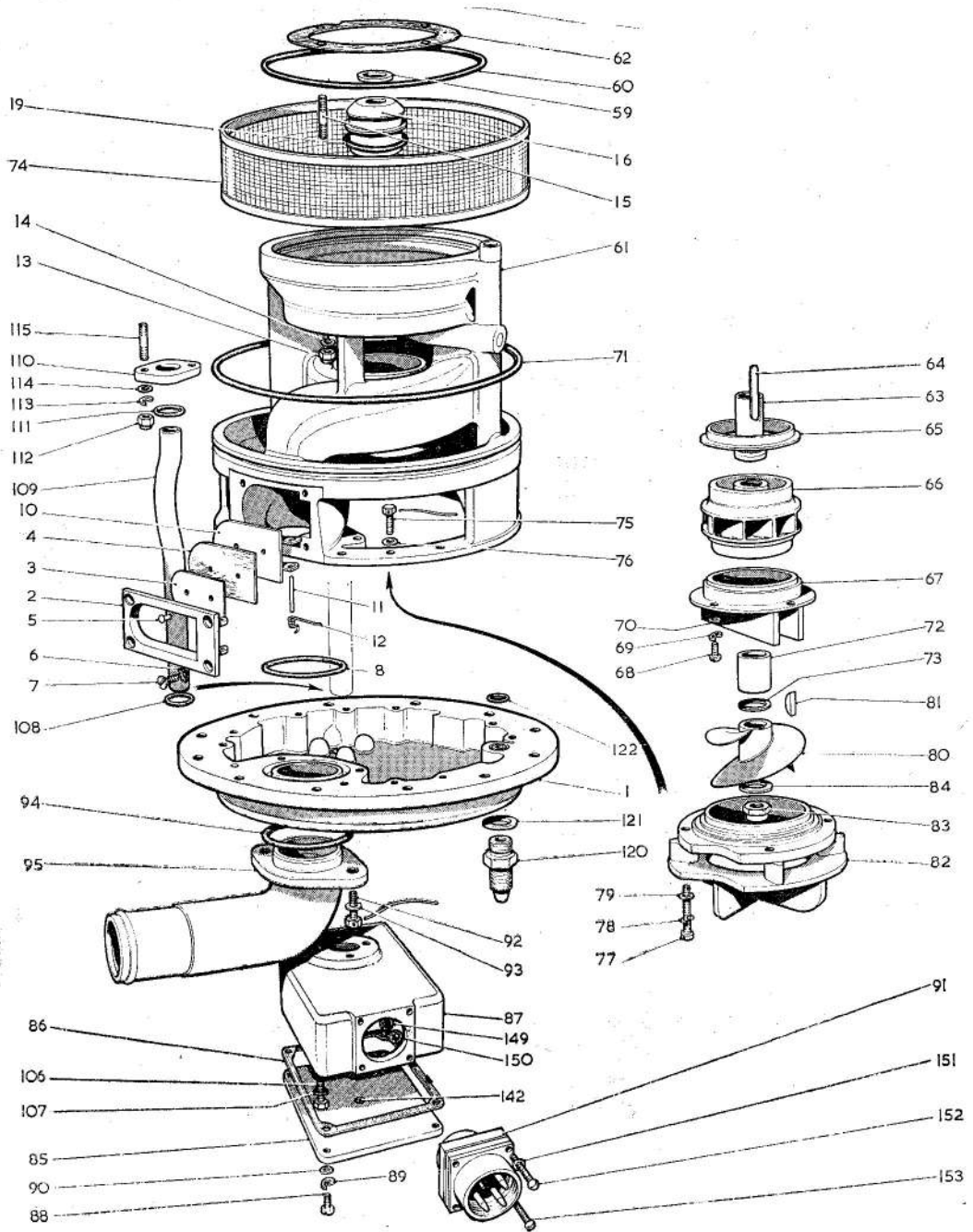

Fig. 7. Exploded view of pump unit (lower end)

~~RESTRICTED~~

### Removing the distance ring and slip ring from the top casting

#### Note . . .

*These components need only be removed from the casting if the bore is badly scored or otherwise damaged.*

14. (1) Pre-heat the top casting to between 125 and 150°C and using the special tools illustrated in Fig. 16, press the distance ring and slip ring sub-assembly out of its housing.
- (2) Refer to Fig. 1. Separate the slip ring (51) from the distance sleeve (50) using the tools illustrated in Fig. 17.

### Dismantling the motor unit

#### Removing the brushes (figs. 18, 20)

15. (1) Using a pair of Seeger 'Circlip' pliers, remove the internal circlip (166) from the liner in the commutator-end casting sub-assembly (172).
- (2) Unlock the tab washers (169) and remove the four nuts (168) securing the commutator-end casting to the frame unit.
- (3) Mark the connections to the brush boxes from the field coils to ensure correct re-assembly.
- (4) Unlock and remove the two 2BA screws (207) securing the field leads to the brush boxes (187). Mark the brushes to identify them with their boxes if they are to be used for a further period of service (this will facilitate re-bedding).
- (5) Lift the brush springs (205) using a shaped piece of wire. Raise the brushes clear of the commutator and allow the ends of the brush springs to rest against the brushes.

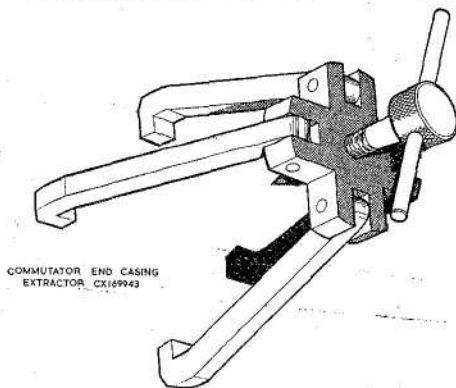

Fig. 8. Extractor for commutator-end casting unit

### Removing the commutator-end casting (fig. 20)

16. (1) Use the four claw extractor CX. 169943 (fig. 8) to pull the commutator end casting sub-assembly (172) away from the frame unit (173). The claws of the extractor should be engaged in the brush box openings around the periphery of the casting and the centre screw tightened against the end of the armature shaft. Great care must be taken to ensure that the centre screw engages properly in the shaft and that the shaft is not distorted.
- (2) Remove the packing washer (164) and pre-loading spring (165) from the armature shaft.

### Withdrawing the armature shaft assembly (fig. 20)

17. (1) Remove the external circlip (160) from the driving end of the motor.
- (2) Support the frame unit on its four studs (170) so that the armature projects through the base-plate of a hand-press and, taking care to protect the end of the shaft with a suitable packing piece, carefully press out the armature. Do not tap the armature out or distort it in any way.

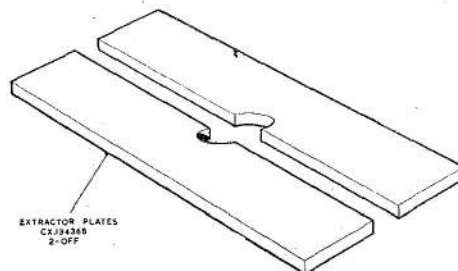
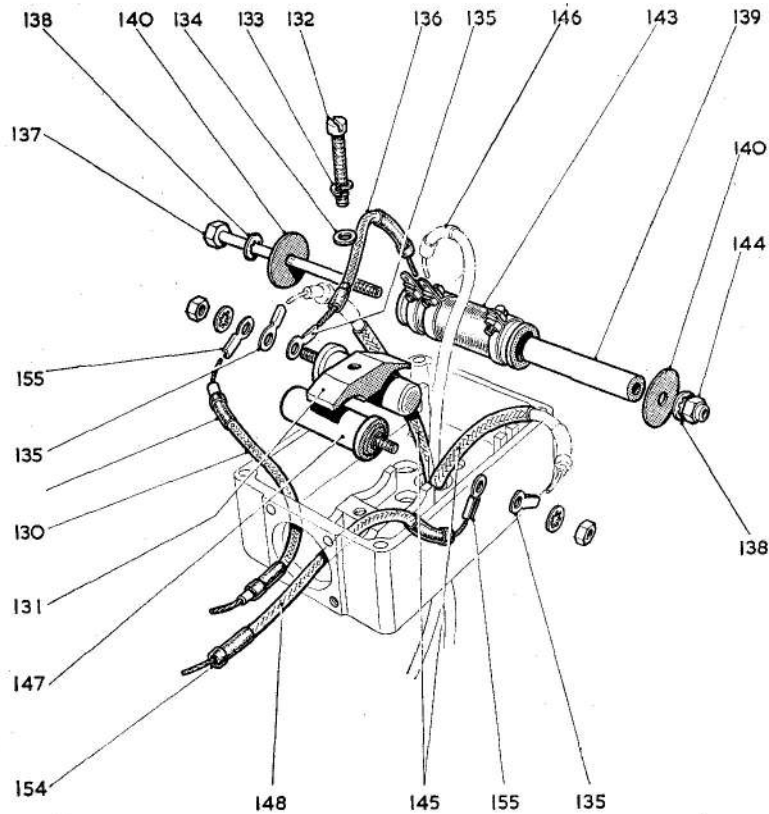

Fig. 9. Extractor plates for removing the commutator-end bearing

- (3) Position the two extractor plates CX.134368 (fig. 9) between the bearing (167) and the commutator and place the plates and armature under an arbor press, holding the armature and locating the plates across a slot in the press turntable. Place a suitable piece of fibre between the armature and the arbor of the press and carefully press out the armature leaving the bearing on the plates.

~~RESTRICTED~~



- |  |  |
|--|--|
| 130 LEAD ASSEMBLY (ELECT. CONN./             | 140 FIBRE WASHER                           |
| SUPPRESSOR UNIT)                             | 143 RESISTOR                               |
| 131 CLAMP PLATE                              | 144 SELF-LOCKING NUT                       |
| 132 CH. HD. SCREW                            | 145 SATURATED GLASS SLEEVING               |
| 133 SPRING WASHER                            | 146 RUBBER SLEEVE                          |
| 134 PLAIN WASHER                             | 147 CAPACITOR                              |
| 135 TERMINAL TAG (MOTOR UNIT LEAD)           | 148 LEAD ASSEMBLY (ELECT. CONN./           |
| 136 LEAD ASSEMBLY (RESISTOR/SUPPRESSOR UNIT) | SUPPRESSOR UNIT)                           |
| 137 RESISTOR BOLT                            | 154 RUBBER SLEEVE                          |
| 138 SHAKEPROOF WASHER                        | 155 TERMINAL (ELECT. CONN./SUPPRESSOR UNIT |
| 139 RESISTOR CENTRE                          | LEADS)                                     |

**Fig. 10. Exploded view of suppressor box assembly**

*Removing the drive-end bearing (fig. 20)*

**18.** (1) Remove the internal circlip (161) from the drive-end of the frame unit and using a  $\frac{3}{4}$  inch diameter brass or hard fibre drift of at least six in. in length, carefully press out the drive-end bearing.

(2) Carefully remove the four studs (15, fig. 7) from the frame unit.

**Note . . .**

*These studs must be removed from the frame unit before re-assembling*

*the ball bearing into the frame unit in the fixture CX.169944 (refer to the assembly instructions, para. 30).*

*Dismantling the commutator-end casing sub-assembly (fig. 21)*

**19.** (1) Mark the positions of the four brush boxes (187) relative to the casting (208). Unlock and remove the remaining two 2BA screws (207) securing the capacitor and brush leads.

(2) Unscrew the two 4BA counter-sunk-head screws (182) securing the

**RESTRICTED**

clips (180) retaining the capacitors (183) and remove the clips and square nuts (181).

(3) Lift out the four brushes (188), allowing the brush springs (205) to rest on the bottom of the slots in the brush boxes.

(4) Turn the commutator-end casting assembly (172) over, and unlock the tabs on each end of the connection strips (193).

(5) Unscrew the four 2BA screws (194) securing the strips and remove together with the spring washers (192), plain washers (191) and flanged insulation

bushes (190). Removal of these screws will free one pair of brush boxes (187), together with their insulation pieces (189).

(6) Unlock and remove the four 2BA screws (195) securing the other pair of brush boxes (187). Lift out the lock-plates (196), spring washers (197), plain washers (198) and insulation bushes (203 and 204) together with the brush boxes.

(7) The four insulation rings (199, 200 and 201) and the connecting ring (202) can now be removed from the casting.

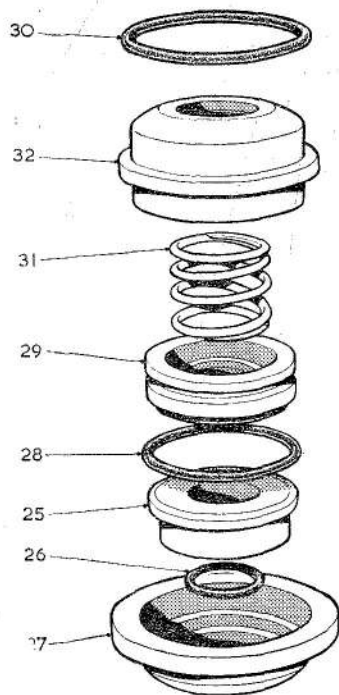

UPPER GLAND ASSEMBLY

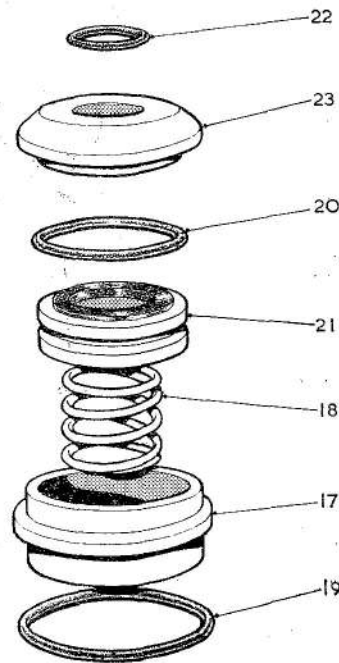

LOWER GLAND ASSEMBLY

17 GLAND HOUSING  
18 GLAND SPRING  
19 GLAND HOUSING 'O' RING  
20 STATIONARY SEAL 'O' RING  
21 STATIONARY SEAL  
22 ROTARY SEAL 'O' RING  
23 ROTARY SEAL

25 ROTARY SEAL  
26 ROTARY SEAL 'O' RING  
27 SLINGER  
28 STATIONARY SEAL 'O' RING  
29 STATIONARY SEAL  
30 GLAND HOUSING 'O' RING  
31 GLAND SPRING  
32 GLAND HOUSING

Fig. 11. Exploded view of upper and lower gland housing assemblies

~~RESTRICTED~~

*Motor torque test*

34. With the brushes completely bedded torque test the motor as follows:--

(1) Hold the motor in a clamp and connect the motor to a suitable d.c. power supply.

(2) Apply a torque of 201.6 oz. in. to the motor by means of a balanced pulley (B.T.H. Ref. CX.169946).

(3) With the input to the motor set at 26V d.c. check that the speed and current consumption of the motor are within the limits quoted as follows:—

Speed 5000 rev/min  $\pm$  50.  
Current consumption 40A  $\pm$  4.

(4) The speed of the motor can be adjusted if necessary by moving the sliding clip of the trimming resistor (143, fig. 3).

*Insulation resistance test*

35. Whilst the motor is still warm, measure the insulation resistance of the motor leads to frame using a 250V insulation resistance tester. The reading obtained should not be less than 10 megohms.

**Pump unit**

*Concentricity check on assembled motor shaft (fig. 7)*

36. (1) Check the concentricity of the motor shaft on the plain lower bearing portion. Total eccentricity must not exceed 0.002 in. total indicator reading.

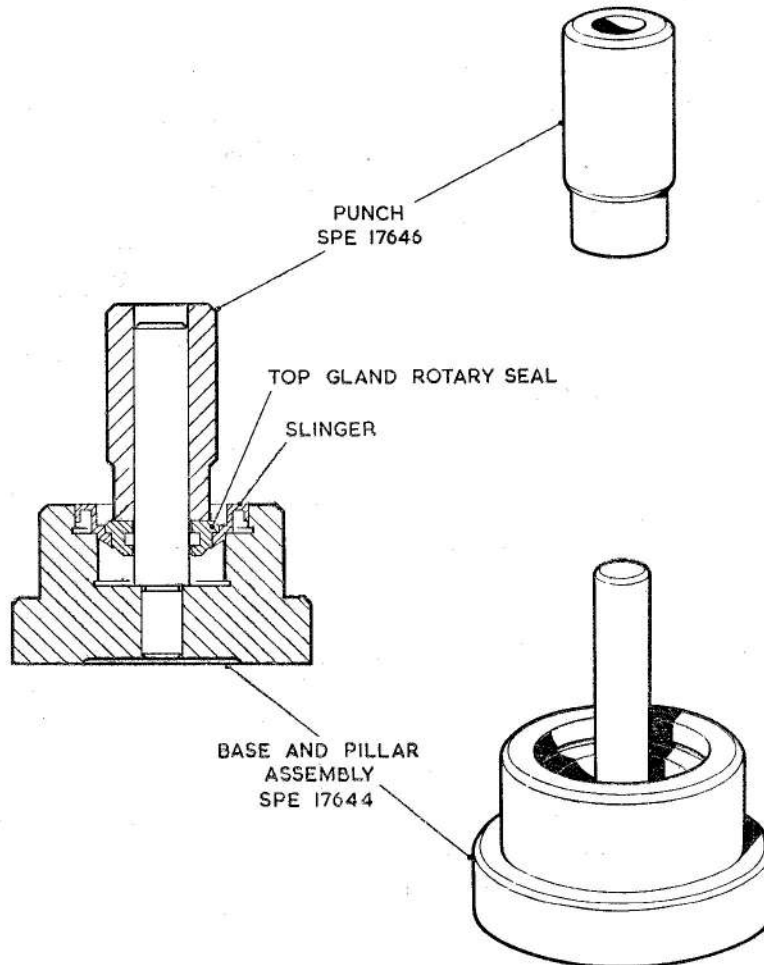

Fig. 23. Tools for assembling the upper rotary seal and slinger

**RESTRICTED**

*Checking the frame unit/motor shaft concentricity*

32. (1) The armature shaft should be mounted on vee-blocks and the concentricity of the 2.999 in.  $\frac{+0.0005 \text{ in.}}{-0}$  diameter spigot of the frame unit checked. This diameter is to be concentric with motor shaft to within 0.001 in. total indicator reading.

- (2) Mount the machined motor spigots on vee-blocks and check for eccentricity for both ends of the shaft. The total indicator reading when the shaft is rotated must be less than 0.002 in.

*Brush bedding motor run*

33. At this stage the brushes should be pre-bedded and the motor ready for a final brush bedding run, continue as follows:—

(1) Connect the lead marked AZ to the negative terminal and connect the leads marked AA and ZZ to the positive terminal, the latter through the resistor (143, fig. 10) supplied for use with the motor. The direction of rotation must be anti-clockwise when viewed from lower (long) end of pump shaft.

(2) Run the machine light on 24V d.c. input for not less than 30 minutes until the brushes are bedded over their full width of arc with at least 80 per cent of their face area in contact with the commutator.

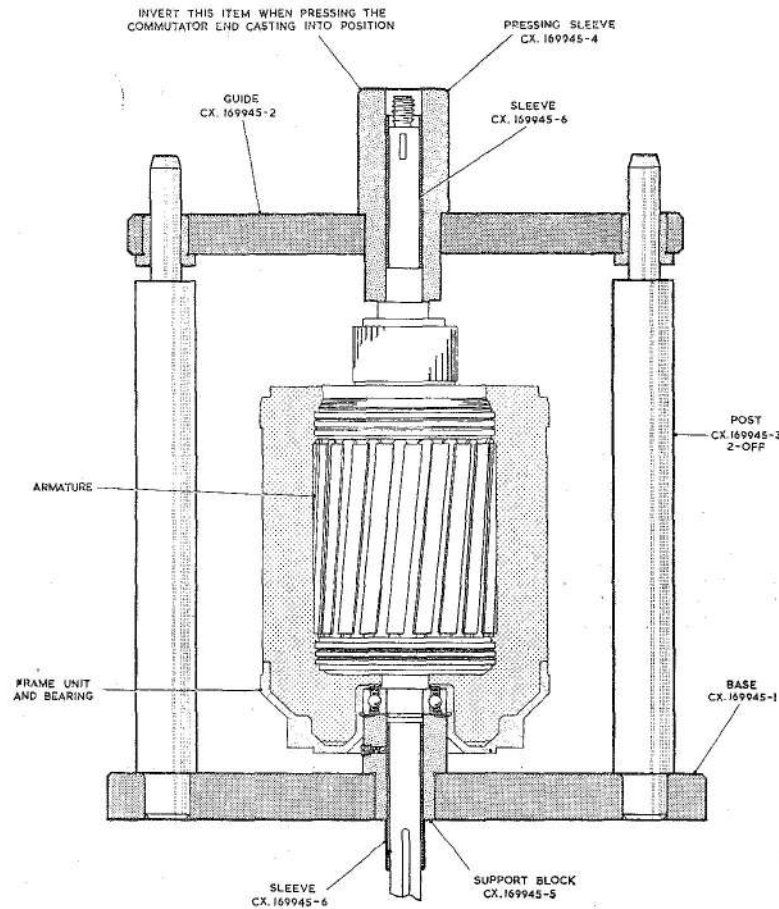

Fig. 22. Fixture for assembling the armature, and the commutator-end units on to the frame unit assembly

~~RESTRICTED~~

(5) Carefully press the armature into the bearing (162, fig. 20) in the frame unit.

(6) Lift off the guide and the pressing sleeve and fit a new ball bearing (167, fig. 20) so that the circlip in the bearing will be nearest to the commutator when fitted. Replace the guide CX.169945-2 and pressing sleeve CX.169945-4 and carefully press the bearing fully home. Lift off the guide and pressing sleeve.

*Assembling the commutator-end casting unit, the frame-unit and the armature sub-assembly (fig. 20)*

31. (1) Screw the four studs (170) into the frame unit so that the longer threaded part of each stud goes into the frame unit. These studs must be square to the frame and perfectly straight.

(2) Fit the commutator-end casting sub-assembly on to its spigot, ensuring that the marks made during dismantling align with each other.

(3) Replace the guide CX.169945-2 (fig. 22) and using the pressing sleeve CX.169945-4 inverted, carefully press

the commutator end casting into position after raising the brushes in their boxes.

(4) Remove the motor unit from the fixture. Fit a 2BA locking tab washer (169) to each stud and secure the casting unit to the frame unit with four 2BA nuts (168). Lock by bending up the washer (169) tangs against the sides of the nuts.

(5) Fit the pre-loading spring (165), packing washer (164) and internal circlip (166) in that order, to the commutator-end bearing liner. The pre-loading spring is to be positioned so that its larger diameter is nearer to the ball race.

(6) Fit the internal circlip (161) to the drive-end of the motor unit and the external circlip (160) into the slot in the armature shaft.

(7) Connect the field leads to their respective brush boxes (refer to identification markings made on dismantling), ensuring that the tags on the field leads are fitted next to the brush boxes.

(8) Lock these screws by bending up the tangs against the screw heads.

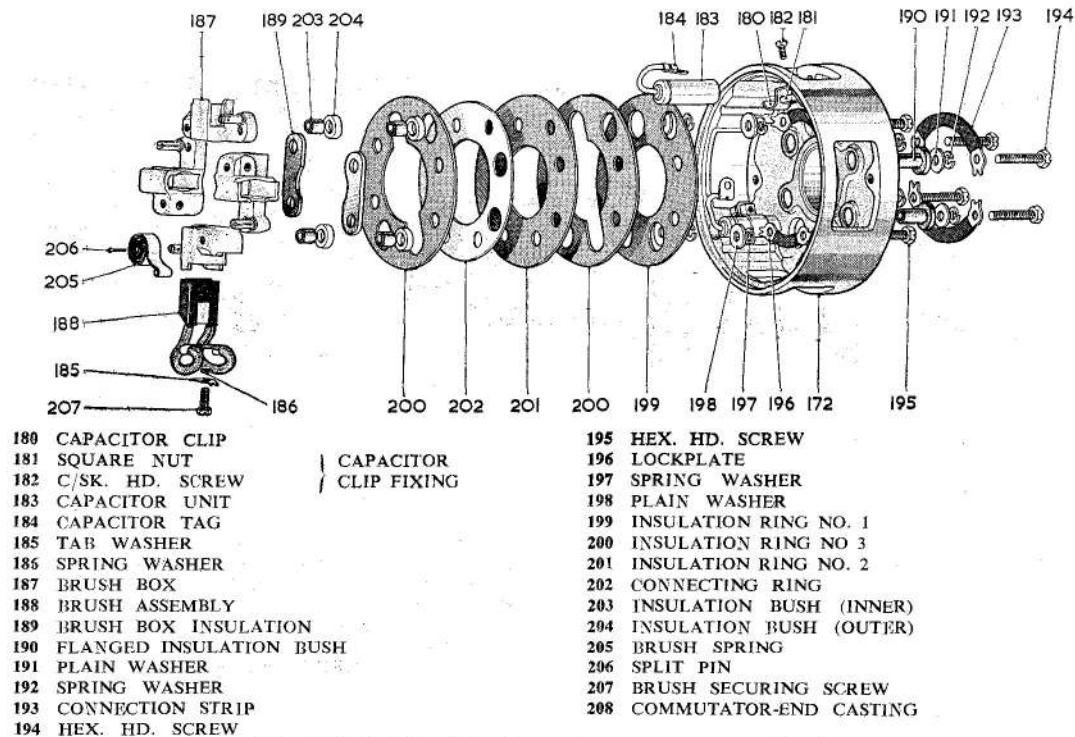

Fig. 21. Exploded view of commutator-end unit

**RESTRICTED**

*Assembling the frame unit and armature*

30. (1) Using the tools illustrated in Fig. 19, locate the commutator-end spigot of the frame unit into the base of the fixture. Fit a new sealed bearing (162, fig. 20) over the location post and, using a hand press and the sleeve, carefully press the bearing into the frame unit.

(2) Position the base, support block and two posts as illustrated in Fig. 22 on the baseplate of a hand press. The base of the press must have a hole in it large enough to clear the armature shaft.

(3) Fit the frame unit (173, fig. 20) and the bearing on to the support block. Fit a sleeve, (CX.169945-6) to each end of the armature shaft (163) and carefully position the armature through the frame unit and the sleeved shaft through the bearing.

(4) Position the guide CX.169945-2 over the posts as shown in Fig. 22 and the pressing sleeve CX.169945-4, over the sleeved shaft.

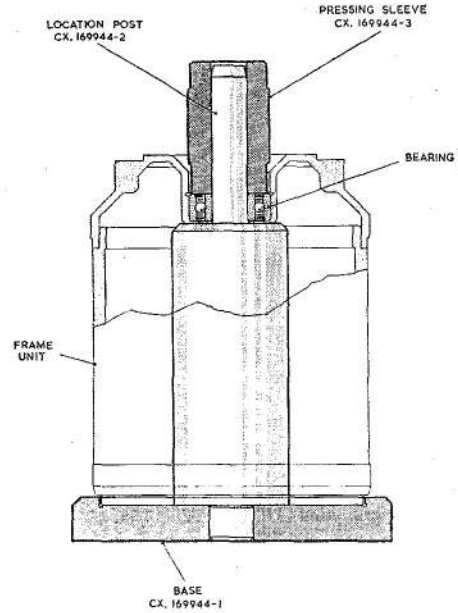

**Fig. 19. Fixture for assembling the drive-end bearing into the frame unit**

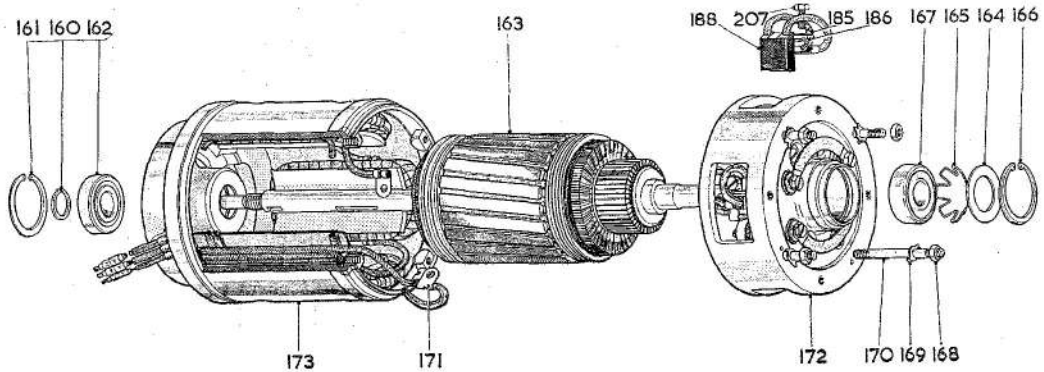

- |   |                                  |
|---|----------------------------------|
| 160 EXTERNAL CLIP                                 | 169 TAB WASHER                   |
| 161 INTERNAL CIRCLIP (DRIVE END BEARING RETAINER) | 170 STUD                         |
| 162 DRIVE-END BALL BEARING                        | 171 TAG                          |
| 163 ARMATURE ASSEMBLY                             | 172 COMMUTATOR-END UNIT ASSEMBLY |
| 164 PACKING WASHER                                | 173 FRAME UNIT ASSEMBLY          |
| 165 PRE-LOADING SPRING                            | 185 TAB WASHER                   |
| 166 INTERNAL CIRCLIP                              | 186 SPRING WASHER                |
| 167 COMMUTATOR-END BALL BEARING                   | 188 BRUSH ASSEMBLY               |
| 168 LOCKNUT                                       | 207 BRUSH SECURING SCREW         |

**Fig. 20. Exploded view of motor unit assembly**

**~~RESTRICTED~~**

29. (1) Fit the four bushes (190) into the commutator-end casting (208) so that the flanged part fits into the recessed hole.

(2) Fit the four 2BA hexagon-head screws (194) into two connection strips (193). On the other side of the connection strip fit a 2BA locking washer (192) and a plain washer (191) to each screw. Insert the connection strip screws into the flanged bushes (190) so that the 2BA plain washers fit next to the flanged part of the bush.

(3) Locate the insulating and connecting ring assembly on to the shanks of the bushes projecting inside the commutator-end casting. Fit a brush box insulation strip (189) over each pair of bush shanks so that the shape of the cutaway part is parallel to the inside bore of the insulating rings.

(4) Fit the remaining brush boxes (187) in position, tighten up the screws (194) and lock them by bending up the tangs of the connection strips.

(5) Lightly smear the capacitor (183)

with petroleum jelly and secure in position in the commutator-end casting (208) by their clips (180), square nuts (181) and 4BA countersunk head screws (182). The screws should be dipped in an approved air drying varnish and screwed home tight.

(6) The brush pigtail leads should be secured to their respective brush boxes (as indicated by identification marks made during dismantling) by a 2BA hexagon head screw (207) fitted with a locking washer (185) and a spring washer (186), the former fitted against the head of the screw. Two of the brush boxes have the capacitor tags (184) fitted to them and these should be included between the pigtail lead and the brush box. The tag should be positioned so that the soldered part of the tag is nearest to the capacitor. Lock the screws securing the capacitor tags by bending up the washer (185) tangs against the screw heads.

(7) Replace the brush springs (205) engaging the inner end of the spring in the slot of the brush box pillar. Retain with a split pin (206).

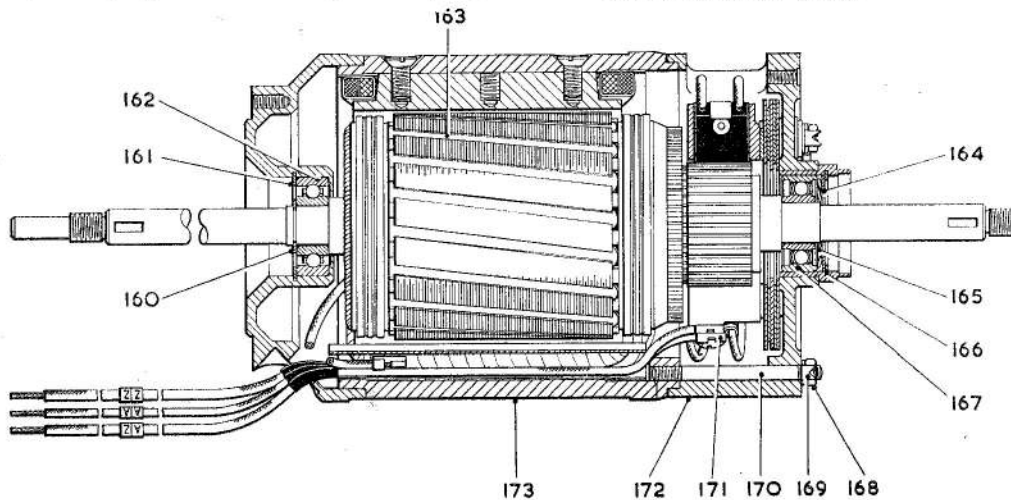

- |  |                                  |
|--|----------------------------------|
| 160 EXTERNAL CIRCLIP                                   | 167 COMMUTATOR-END BALL BEARING  |
| 161 INTERNAL CIRCLIP (DRIVE END BEARING RETAINER)      | 168 LOCKNUT                      |
| 162 DRIVE-END BALL BEARING                             | 169 TAB WASHER                   |
| 163 ARMATURE ASSEMBLY                                  | 170 STUD                         |
| 164 PACKING WASHER                                     | 171 TAG                          |
| 165 PRE-LOADING SPRING                                 | 172 COMMUTATOR-END UNIT ASSEMBLY |
| 166 INTERNAL CIRCLIP (COMMUTATOR-END BEARING RETAINER) | 173 FRAME UNIT ASSEMBLY          |

Fig. 18. Sectional view of the motor unit assembly

~~RESTRICTED~~

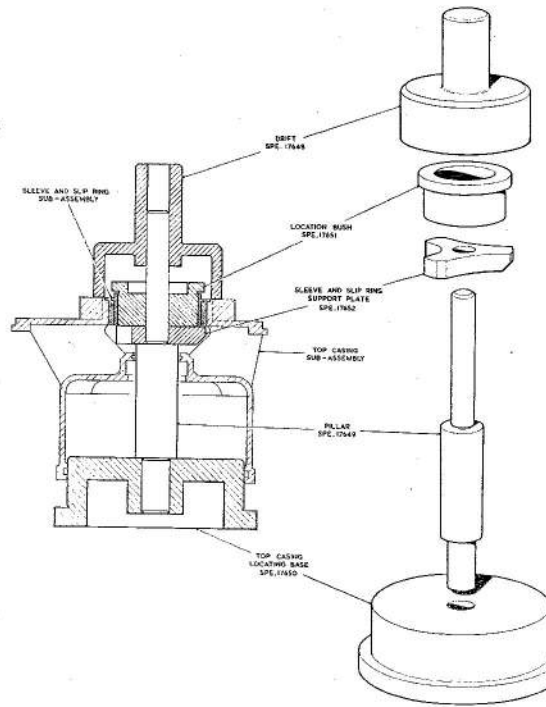

Fig. 16. Tools for removing the slip-ring distance sleeve sub-assembly from the top casing

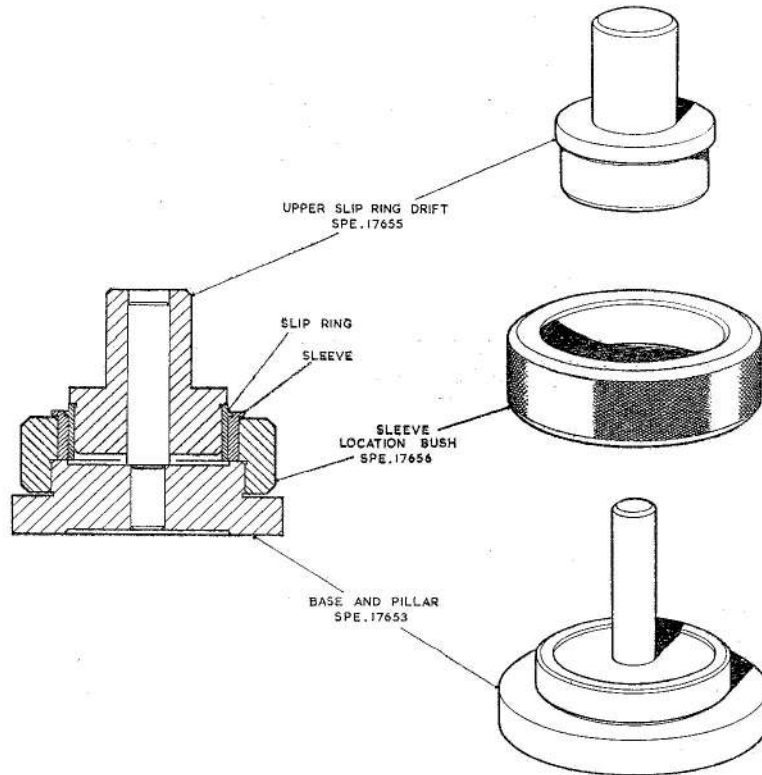
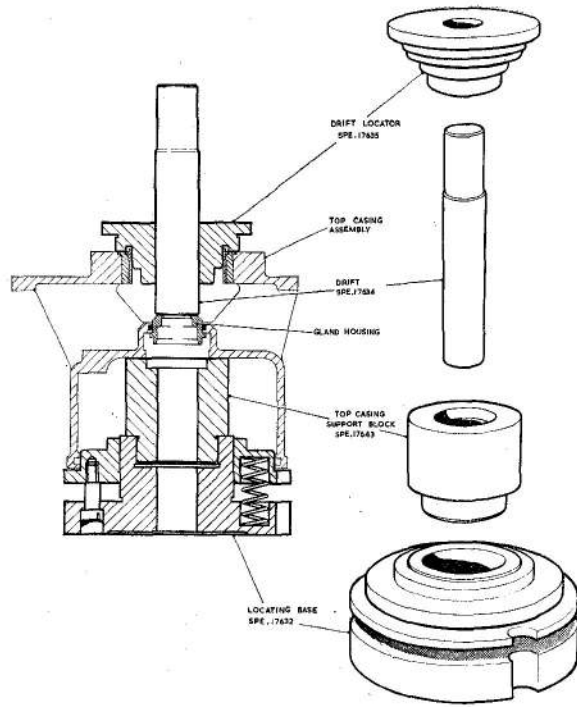
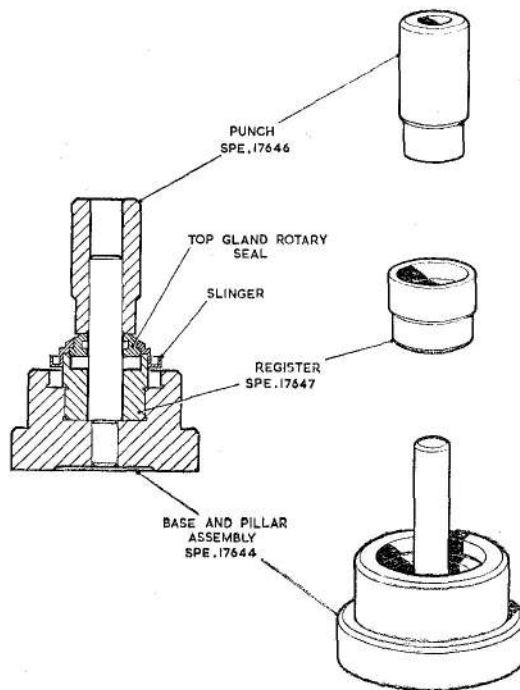

Fig. 17. Tools for separating the slip ring and distance sleeve

~~RESTRICTED~~



**Fig. 14. Tools for removing the top casing gland housing**



**Fig. 15. Tools for dismantling the upper rotary seal/slinger sub-assembly**

**RESTRICTED**

**ASSEMBLING****General**

27. (1) Maintain absolute cleanliness of the work-bench and tools throughout the assembly of the pump. Use the special tools or their equivalents where specified. Retain the bearings in their wrappings until required for assembly.
- (2) New or original brushes being refitted for a further period of service, should be pre-bedded in accordance with the method described in A.P.4343, Vol. 1, Sect. 1, Chap. 2. To avoid repetition the method is not given for this motor unit, but should be allowed for at the appropriate assembly stage.
- (3) Throughout the assembly of this pump, when spring and plain washers are called for under the heads of the securing screws, the spring washers should be assembled immediately under the screw head and the plain washer between the spring washer and the component being secured.

**Motor unit**

*Re-assembling the commutator-end casting unit (fig. 20)*

28. (1) If any commutator-end casting retainer studs (170, fig. 21) have been removed from the yoke for renewal or inspection purposes, they must be refitted so that the ends marked with a drill-point are visible after insertion.
- (2) Fit the four 2BA hexagon head screws (195) into two lockplates (196).

On the other side of the lockplate fit a 2BA locking washer (197) and an 0-080 in. thick plain washer (198) to each screw.

(3) Line up the three insulating rings (199, 200 and 201) and the connection ring (202) in the order illustrated in Fig. 21. Insert the lockplate screws (195) from the insulating ring No. 1 (199) side so that the washers on the screws fit inside the insulating rings No. 1 and 3 (199 and 200 respectively). The curved profile of the lockplate should be concentric with the inside bore of the rings.

(4) Turn the sub-assembly over on to a flat surface. Fit an inner insulation bush (203) over each screw to locate against the 0-080 in. thick washer (198). Over each inner bush fit an outer insulation bush (204) then fit a further insulating ring No. 3 (200).

(5) Carefully lift up one side of the stacked rings and fit the appropriate brush box (187) so that the brush spring slot is nearest to the outside diameter of the rings. Similarly fit the other brush box diametrically opposite.

(6) Using the four flanged insulation bushes (190) to line up the five rings tighten up the four screws and lock them by bending up the tangs on the lockplates (196). Remove the four bushes (190). The lockplates, screw-heads and exposed parts of the plain washers should be given a coat of BTH.378 paint.

**RESTRICTED**

TABLE 3—(contd.)

Parts and description	Dimensions New	Permissible worn dimen- sions for further use.	Clearance New	Permissible worn clear- ances for re-use.	Remarks
KEYWAYS IN ARMATURE SHAFT	$\frac{3.175\text{mm.}}{3.145\text{mm.}}$ $\frac{(0.125\text{in.})}{(0.124\text{in.})}$	3.175mm. max. (0.125in. max.)	—	—	—
BOTTOM PROPELLER TO BAFFLE PLATES  Clearance	—  —	—  —	$\frac{0.381\text{mm.}}{0.254\text{mm.}}$  $\frac{(0.015\text{in.})}{(0.010\text{in.})}$	$\frac{0.381\text{mm.}}{0.254\text{mm.}}$  $\frac{(0.015\text{in.})}{(0.010\text{in.})}$	Adjust by means of shims.

RESTRICTED

TABLE 3—(contd.)

F.S./13

Parts and description	Dimensions New	Permissible worn dimensions for further use.	Clearance New	Permissible worn clearances for re-use.	Remarks
GLAND CARBON (PROTRUSION OF CARBON FROM COLLAR OF STATIONARY SEAL HOUSING)	0.82mm. 0.66mm. (0.042in.) (0.026in.)	0.5mm. (0.020in.)	—	—	—
PROPELLERS IN SLIPRINGS	dia. { 56.70mm. 56.39mm. (2.232in.) (2.230in.)	55.95mm. (2.2296in.)	0.545mm. 0.457mm. (0.0216in.)	0.66mm. (0.026in.)	—
			(0.018in.)		
ROTARY SEALS	bore { 57.19mm. 57.15mm. (2.2516in.) (2.25in.)	57.24mm. (2.2536in.)	—	—	Lap seating face to remove slight scoring.
			thickness { 7.97mm. 7.91mm. (0.3135in.) (0.3115in.)	7.82mm. (0.308in. min.)	

**RESTRICTED**

A.P.4343D, Vol. 6, Book 2, Sect. 7, Chap. 41  
A.L.117, Feb. 63

TABLE 3—(contd.)

Parts and description	Dimensions New	Permissible worn dimen- sions for further use.	Clearance New	Permissible worn clear- ances for re-use.	Remarks	
<b>PUMP UNIT</b>						
PUMP SHAFT IN CARBON BEARING	dia.	7.72mm.	0.06mm.	—	Bore to be concentric with location spigot of bearing housing within 0.001in. total indicator reading.	
		7.70mm.	0.012mm.	—		
		(0.304in.)	—	—		
		(0.303in.)	—	—		
		7.76mm.	0.0025in.	—		
		7.73mm.	0.0005in.	—		
IMPELLER IN SLIPRINGS	dia.	47.81mm.	0.38mm.	0.5mm.	—	
		47.28mm.	0.32mm.	(0.020in.)	—	
		(1.8625in.)	47.28mm. (1.8595in.)	—	0.5mm.	—
		(1.8615in.)	—	(0.0149in.)	(0.020in.)	—
		47.66mm.	47.72mm. (1.8785in.)	(0.0125in.)	0.5mm.	—
		47.63mm.	—	—	0.5mm.	—
	bore	(0.3055in.)	—	0.5mm.	—	
		(0.3045in.)	—	0.5mm.	—	

RESIDUAL

**SCHEDULE OF FITS, CLEARANCES AND REPAIR TOLERANCES**  
**TABLE 3**

Parts and description	Dimensions New	Permissible worn dimen- sions for further use.	Clearance New	Permissible worn clear- ances for re-use.	Remarks
<b>MOTOR UNIT</b>					
BRUSH LENGTH TO CENTRE OF RADIUS	23mm.	14.0mm. (0.551in.)	—	—	—
COMMUTATOR DIAMETER	$\frac{44.55\text{mm.}}{44.45\text{mm.}}$	41.9mm. (1.65in.)	—	—	Diamond turn. No tool marks permissible.
COMMUTATOR: UNDERCUT DIAMETER ADJACENT TO RISER (2 mm. (0.079 in.) WIDE)	43.0mm.	40.45mm. (1.593in.)	—	—	—
ARMATURE END FLOAT	—	—	0.006in. max. (0.15mm.)	0.009in. max. (0.225mm.)	—
ARMATURE SPINDLE IN DRIVE- END BALL RACE	$\frac{14.986\text{mm.}}{14.978\text{mm.}}$	14.978mm.			Selective assembly.
bore	$\frac{15.000\text{mm.}}{14.990\text{mm.}}$	15.000mm.			
ARMATURE SPINDLE IN COM- MUTATOR-END BALL RACE	$\frac{14.986\text{mm.}}{14.978\text{mm.}}$	14.978mm.			Selective assembly.
bore	$\frac{15.000\text{mm.}}{14.990\text{mm.}}$	15.000mm.			

**RESTRICTED**

**TABLE 2—(contd.)**

Item	Examination	Action if faulty
Carbon bearing	Refer to Table 3.	
Seal rings: Bonded seal washers		Renew all components of this nature on re-assembly.
Mounting plate	Check thread inserts	Do not plug faulty insert tappings. Renew mounting plates.
Electrical connection	Damaged thread: pins or plates.	Renew.
Top casting and pump casing	Damage. Damaged threads.	Reject.
Canister	Dented. End diameter to be 7.0 in. + .001, + .003 in.	Reform, if possible.

**RESTRICTED**

TABLE 2—(contd.)

Item	Examination	Action if faulty
Commutator end casting assembly (contd.)	Check clearance between brushes and brush boxes Long side—0.001/0.012 in. Short side—0.001/0.007 in. Brush springs to be sound and free from corrosion. Check pressure. In normal working position (with new brush fitted) the spring should exert a force within the limits of 1.5 lb. $\pm$ 10 per cent. Check ball race liner bore (Table 3).	Reject.  Reject and renew.  Reject.
Bearings	It is recommended that the bearings are renewed at each reconditioning.	
Capacitors	Check capacitance — to be 0.6 $\mu$ F minimum. Insulation resistance measured with a 250-volt insulation resistance tester to be 20 megohms minimum.	Reject. Reject.
Bearing pre-load spring	Check spring for pressure. It should compress to a length of $\frac{1}{16}$ in. when under load within limits of 14.0/17.0 lb.	Reject and renew.
Resistor	Examine for damage. Check for continuity. Total resistance to be within limits 15 ohms $\pm$ 10 per cent at 20°C.	Reject and renew.
Glands	Scoring or pitting of seal faces.	If slight, relap. If excessive renew.
Slip rings	Scoring, particularly localised scoring due to impeller or propeller eccentricity on shaft.	Reject and renew.
Strainers	Damaged mesh.	Renew.

~~RESTRICTED~~

TABLE 2—(contd.)

Item	Examination	Action if faulty
Armature (contd.)	Check that the widths of all keyways are within limits 0.124 in./0.125 in. and that they are undamaged.	Reject armature.
Frame unit	<p>Connections and insulation coverings of windings and leads to be secure and undamaged.</p> <p>Insulation resistance must not be less than 50 megohms when measured with a 250-volt insulation resistance tester.</p> <p>Resistance of field coils. Total resistance must be 24 ohms <math>\pm</math> 10 per cent at 20°C.</p> <p>Frame unit for cracks or damage. Refer to Table 3 for bearing limits.</p>	<p>Slight damage to field leads can be repaired by covering the damaged part with varnished glass insulation sleeving held in place with thread. Varnish the repair with BTH.3079 air-drying varnish and allow to dry for at least 12 hours. If any re-soldering is required use only high-melting-point solder (3 parts lead: 1 part tin).</p> <p>If necessary equipment is available, proceed as follows:—                      (1) Clean the yoke and field coil unit thoroughly to remove every trace of dust from the windings.                      (2) Bake the unit in a ventilated oven at 105°C for four hours, dip into BTH.377 varnish until bubbles cease to rise (the varnish should not be permitted to enter the bearing housing of the driving-end casting) and, after removing excess varnish from the yoke surface, place the unit in a vacuum oven for eight hours at 150°C.                      (3) Recheck the insulation resistance value.</p> <p>Reject.</p> <p>Reject.</p>
Commutator end casting assembly	<p>All spigot diameters and faces for damage.</p> <p>Insulation bushes and rings for damage.</p> <p>Brush boxes for damage. Ensure that slots are free from burrs.</p> <p>Brushes for wear (Table 3).</p>	<p>Reject.</p> <p>Reject.</p> <p>Reject: Remove any burrs.</p> <p>Renew.</p>

~~RESTRICTED~~

**TABLE 2**  
**Detailed examination of components**

Item	Examination	Action if faulty
Armature	Laminations and end windings for signs of fouling or other damage.	Reject armature for re-winding.
	Commutator for loose conductors.	Reject.
	Local discoloration of the commutator.	Suspect faulty windings. Check using voltage-drop method.
	Insulation resistance between armature and shaft. Use a 250 volt insulation resistance tester.	If less than 50 megohms, clean armature thoroughly to remove every trace of dust from the windings. Bake the armature for eight hours in a ventilated oven at 105°C and dip it in B.T.H.377 varnish until bubbles cease to rise. Remove excess varnish from shaft and commutator surfaces, place in a vacuum oven for 4 hours at 105°C. Bake in a ventilated oven for 8 hours at 150°C. Brush coat the ends of the windings with BTH.3047 varnish and bake in a ventilated oven at 150°C for eight hours. Repeat this last varnishing. Re-check the insulation value.
	Check resistance of windings. Resistance between commutator segments 90° apart must be 0.016 ohm ± 10 per cent at 20°C.	Reject armature.
	Commutator for eccentricity—total indicator reading must not exceed 0.001 in.	If excessive—reject. Check for high mica and raised commutator segments. Difference in indicator readings between adjacent segments is not to exceed 0.0001 in.
	Commutator for scoring.	Skim commutator. Minimum permissible diameter for further use is 41.9 mm. (1.65 in.). Surface finish must be free from all machine marks. Undercut mica 0.03 in. deep × 0.022 in. max. width. Check that no copper burrs are shorting across segments—remove by gentle application of the finest steel wool. When skimming the commutator deepen the 2 mm. wide undercut adjacent to the riser but do not reduce its diameter below 40.45 mm. (1.593 in.).
Short or open circuited conductors. Use voltage-drop tester or growler.	Clean undercutting of mica between commutator segments (see above). Remove copper burrs and slivers of mica. If still unsatisfactory reject armature.	

**~~RESTRICTED~~**

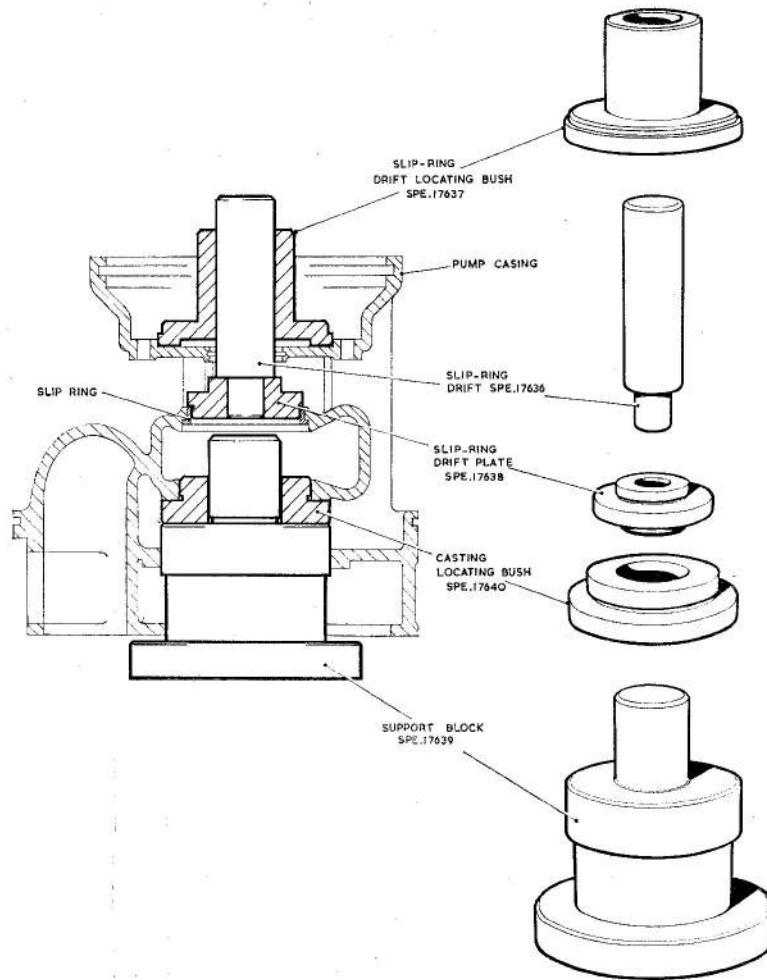

**Fig. 13. Tools for removing the upper impeller slip-ring from the pump casing**

## Examination

### General

**24.** Examine all metal components for cleanliness, distortion, cracking (visual), scoring, denting, visual evidence of wear, deterioration of protective finishes (corrosion), serviceability of threads, security of sub-assemblies not dismantled (e.g. riveting) and discolouration due to overheating. Examine re-usable rubber components and electrical cable insulation for cleanliness, chafing, cracking, cuts, overheating, fluid soakage and general deterioration. All seal

rings and bonded seal washers must be renewed on re-assembly.

### Detailed procedure

**25.** Parts should be inspected in accordance with Table 2 and checked for conformity with the Schedule of Fits, Clearances and Repair Tolerances given in Table 3.

### Lapping rotary and stationary seal faces

**26.** Details of the procedure for hand lapping rotary and stationary seal faces is given in Chapter 6A of Section 8.

**RESTRICTED**

*Frame unit*

20. (1) Do not attempt to remove the coils from the frame unit.

### CLEANING, EXAMINATION AND REPAIR

**Cleaning**

21. Clean the armature and field assembly thoroughly to remove all traces of dust and grease from the windings and metal parts. Ensure that all dried jointing compound is removed from mating pump and motor unit component surfaces, using an approved remover if necessary. All components except bearings, seal rings, brushes and the electrical connection should be cleaned in an

approved cleaning solvent, or if excessively dirty, in a heavy duty degreasant. After cleaning, blow off surplus solvent, allow to dry off for 12 hours and complete drying in a ventilated oven at approximately 105°C.

22. The ball bearing journals fitted on this pump are of the pre-packed type and should last between major servicing period when they should be renewed.

23. Synthetic rubber components should be renewed on re-assembly. If it is absolutely necessary to re-use such a component, it must only be cleaned in lead-free gasoline—not in trichlorethylene or any similar degreasant.

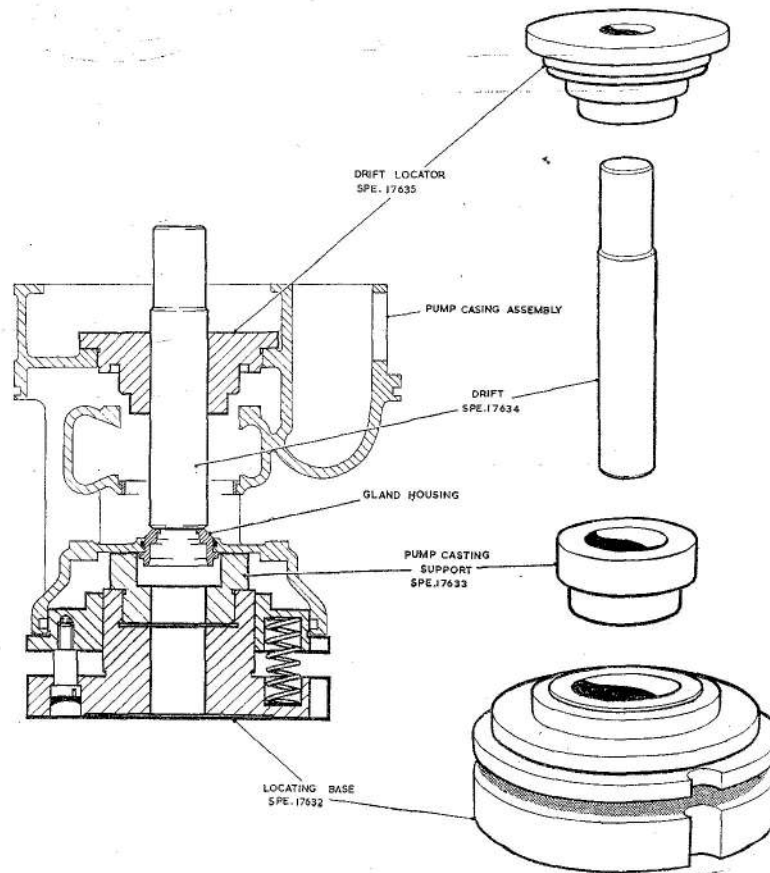
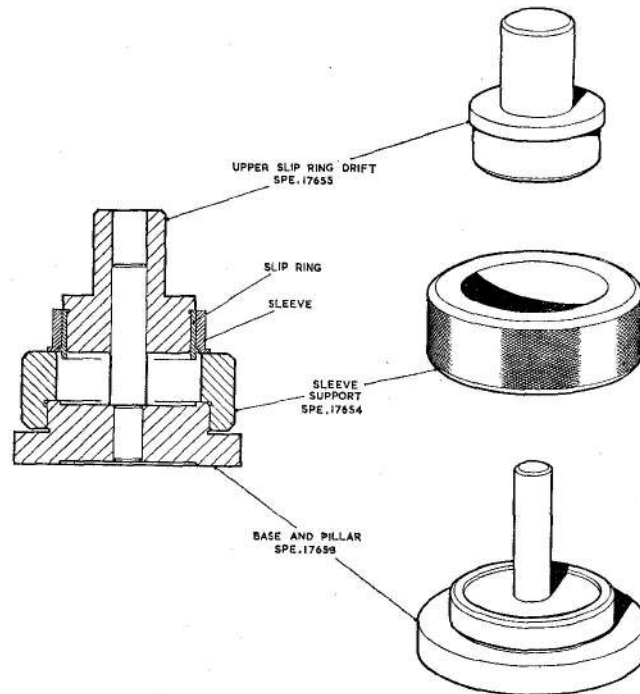

Fig. 12. Tools for removing the lower gland housing

~~RESTRICTED~~



**Fig. 24. Tools for assembling the top casing slip-ring and distance sleeve**

**Note . . .**

*Concentricity check should be made as near to the end of the shaft as possible.*

(2) Remove the shaft circlip (160, fig. 20) fitted to the motor unit adjacent to the lower bearing. Position a spacer (59), the slinger component on the gland (23, fig. 11) and a distance piece (63) on the armature shaft. Fit a feather key (64) in the shaft groove and position the double-inlet impeller (66) and distance sleeve (71). Fit a Woodruff key (81) in the lower shaft groove and position the lower propeller (80). Secure all components to the shaft with a plain washer (84) and self-locking nut (83).

**Note . . .**

*The mating faces of the plain washer must be flat and parallel with each other. The mating face of the nut (83) must be square with its thread and should be machined if necessary.*

(3) Tighten the nut and re-check the concentricity of the shaft as close to its end as possible. Total indicator reading must not exceed 0.002 in. If eccentricity is excessive, slacken the nut and rotate the distance pieces in turn through 90 degrees, re-tighten the nut and re-check the concentricity of the shaft. Continue to adjust or replace components as required until a total indicator reading of 0.002 in. or less is obtained with the shaft components tightened.

(4) Mark all components so that they can be re-assembled in exactly the same positions relative to one another at a later assembly stage.

(5) Remove the nut and withdraw all components from the shaft. If more than one pump is being assembled, each set of components should be suitably marked so that they can be re-built into the same unit.

**RESTRICTED**

### *Assembling the top casing*

37. (1) Pre-heat the slinger (27, fig. 11) to between 125 and 150°C, smear the bore with Hermetite sealing compound and using the tools illustrated in Fig. 23, press the rotary seal ring (25) into the slinger. Wipe off any excess joint compound and allow to cool.

(2) Refer to Fig. 4. Pre-heat the distance sleeve (50) to between 125 and 150°C and using the tools illustrated in Fig. 24 press the slip ring (51) into the distance sleeve.

(3) Pre-heat the top casing (55) to between 125 and 150°C and using the tools illustrated in Fig. 26 press the distance sleeve/slip ring sub-assembly into position.

(4) Refer to Fig. 11. While the top casing is still warm or after re-heating, smear a new seal ring (30) with Silicone MS.4 grease, compound XG250 (Ref. No. 33H/9424829) and position in the groove in the casting bore. Smear Hermetite jointing compound on the mating surface of the gland housing (25) and top casing (on each side of the joint ring) and using the tools illustrated in Fig. 27, press the gland housing into position in the top casing.

(5) Lubricate a new seal ring (28) with XG.250 and locate it in the groove in a new or reconditioned stationary seal ring body (29).

(6) Lubricate a new seal ring (26) with XG.250 and fit it into the internal groove of the rotary seal ring/slinger sub-assembly (sub-para. (1)). Position this assembly on the short end of the armature shaft with the lapped face uppermost. Check that the labyrinth of the slinger does not foul the spigot of the motor end casting.

(7) Refer to Fig. 4. Lubricate a new seal ring (54) with XG.250 and position it at the base of the motor-end casing spigot.

(8) Lubricate a new seal ring (56) with XG.250 and fit in internal groove in the open end of the top casing (55).

(9) Refer to Fig. 11. Fit the spring (31) into the assembled gland housing (32) together with the stationary seal ring body sub-assembly (sub-para. (5)).

(10) Position the top casing sub-assembly over the armature shaft, aligning the four 0.218 in. dia. holes with the 2BA tapped holes in the motor casing and radially aligning the gland drain channel with the motor unit nameplates. Take care that the stationary seal ring (28) is not displaced from the gland housing.

### **Note . . .**

*Remove any masking tape fitted around the brush gear access 'windows' of the motor unit.*

(11) Secure the top casing to the motor unit with four 2BA hexagon head screws and seal washers (34 and 33, fig. 4).

### *Assembling the upper propeller (fig. 4)*

38. (1) Fit the distance piece (53) over the motor shaft, small diameter end first, through the gland spring, so that it seals on the rotary seal ring (25, fig. 11).

(2) Place a new key (42) in the upper shaft keyway and fit the right hand propeller (41). Rotate the armature shaft to check that the impeller will not foul the slip ring.

(3) Secure the shaft components with a plain washer (45) and self-locking nut (44). Tighten securely.

(4) Replace the vapour deflector (49), securing to the top casing with four 4BA cheese-head screws (38), spring washers (39) and plain washers (40).

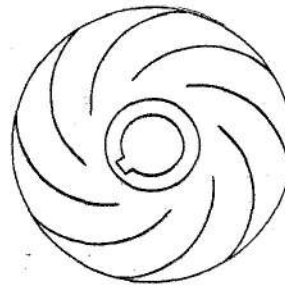

**Fig. 25. View on the end of the shaft showing the impeller vanes**

### *Assembling the pump casing sub-assembly*

39. (1) Pre-heat the pump casing (61, fig. 7) to between 125 and 150°C, smear a new seal ring (19) with Silicone MS4

~~RESTRICTED~~

grease, compound A.339 and position it in the groove in the casting bore. Smear Hermetite jointing compound on the mating surfaces of the gland housing (17, fig. 11) and pump casing (on each side of seal ring) using the tools illustrated in Fig. 27, press the gland housing into position in the pump casing.

(2) While the pump casing is still warm or after re-heating, use the tools illustrated in Fig. 30 to press the slip ring (65, fig. 7) into position.

(3) Lubricate a new seal ring (20, fig. 11) with Silicone MS.4 grease, compound XG.250 and fit it into the groove in the stationary seal ring body (21).

(4) Fit the gland spring (18) into the

assembled gland housing (17) and the stationary seal ring sub-assembly to the spring. 'Screw' the spring into the housing and the seal ring on to the spring so that the spring bottoms in both components.

(5) Lubricate two new seal rings (123, fig. 4) with Silicone MS.4 grease compound XG.250 and fit them into the seatings in the gland drain ferrules in the top casing and the pump casing. Insert the gland drain tube (124) into the top casing ferrule.

(6) Refer to Fig. 7. Lubricate a new seal ring (60) with Silicone MS.4 grease compound XG.250 and locate in its seating just inside the upper end of the pump casing (61).

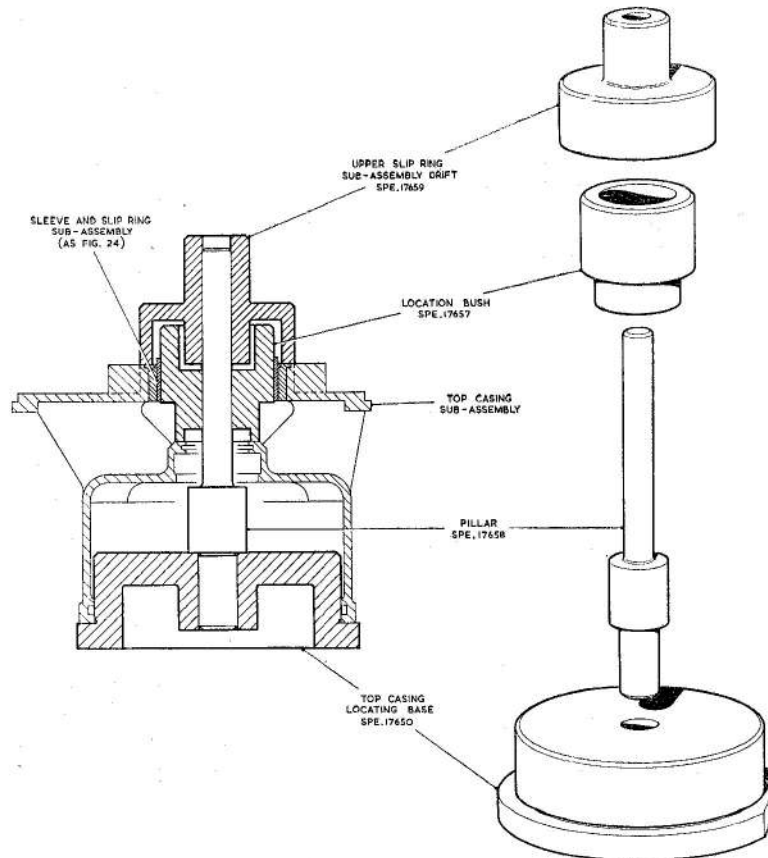
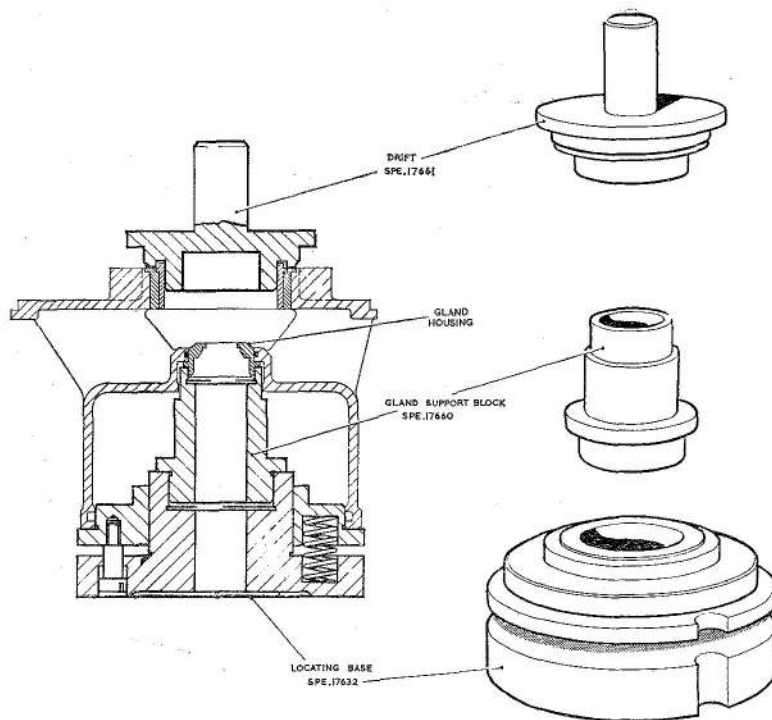

Fig. 26. Tools for assembling the slip-ring/distance sleeve sub-assembly to the top casting

RESTRICTED



**Fig. 27. Tools for assembling the upper gland housing to the top casing**

(7) Replace the studs (15) in the end of the motor casing.

(8) Position a new paper gasket (62) over the motor unit studs.

(9) Replace any damaged studs (115) in the pump casing. Pass the end of the motor lead tube (109) nearest to the slight bend through the clamp plate (110) from the unrecessed side until it projects approximately 0.0312 in. Lubricate a new seal ring (111) with Silicone MS.4 grease, compound XG.250, and pass it over the end of the tube and locate in the recess in the clamp plate. Smear the surface of the tube above the seal ring with Hermetite jointing compound. Fit the clamp plate over the studs (115) and secure with plain washers (114), spring washers (113) and locknuts (112). Tighten after checking that the end of the lead tube (109) is below the motor unit seating face of the casing.

*Fitting the pump casing to the motor unit*

40. (1) Lubricate a new seal ring (22, fig. 11) with Silicone MS.4 grease, compound XG.250 and fit into the internal

groove of the rotary seal ring (23) previously used in checking the concentricity of the assembled shaft (para. 36).

**Note . . .**

*The main shaft components fitted in an assembly should be those used with selected rotary seal rings for the concentricity check (para. 36). Marks made on each component should be aligned so that each is assembled in the same relative position as for the check. Components referred to are marked with an asterisk in the following paragraphs.*

(2) With the top casing/motor assembly inverted in a suitable stand, fit the spacing bush \*(59, fig. 7) against the inner race of the lower bearing after checking that the shaft circlip (160, fig. 20) has been removed (it will not normally have been replaced after the shaft concentricity check, para. 36). Position the rotary seal ring sub-assembly\* (sub-para. (1)) with lapped face uppermost, against the spacer.

**RESTRICTED**

(3) Roughly align the pump casing sub-assembly over the armature shaft so that the top casing gland drain tube (124, fig. 4) is in line with the ferrule and the continuation of the gland drain channel in the pump casing. Thread the motor unit leads into the tube. Locate the casing over the motor studs and the gland drain tube in the pump casing ferrule. Check that the seal ring (123, fig. 4) is not dislodged. Secure the casing to the motor unit with self-locking nuts (13, fig. 7) and plain washers (14).

(4) Attach a dial test indicator to the armature shaft and check that the end bearing diameter of the shaft is concentric with the 2.937 in. dia. bore of the pump casing to within 0.002 in. total indicator reading.

*Assembling the lower pump shaft components (fig. 7)*

41. (1) Fit the distance sleeve\* (63) small diameter end first, over the armature shaft. Position so that it passes through the gland spring and seats on the lapped surface of the rotary seal ring\* (23, fig. 11). Rotate the shaft and check by feel that there is no interference between the distance sleeve and the compressed gland spring.

(2) Fit a new feather key (64, fig. 7) in the shaft keyway and position the double entry impeller\* (66) on the shaft. This must be assembled so that when viewed from the end of the armature shaft, the vanes of the impeller appear as illustrated in Fig. 25. Align the concentricity check mark on the distance sleeve\* (63) with that on the impeller. With finger pressure on the end of the impeller, rotate the shaft and feel that there is no interference between the impeller and the slipring.

(3) Reposition the bottom baffle and slip ring assembly\* (67) and secure to the pump casing with four round head screws (68), spring washers (69) and plain washers (70). Tighten the screws. With finger pressure on the end of the impeller, rotate the shaft and feel and observe that there is no interference between the impeller and the slip ring.

(4) Fit the lower distance sleeve\* (72) on the shaft, fit a new Woodruff key (81) in the keyway and position the left-hand propeller\* (80). Fit shims (73) as necessary between the sleeve and the propeller so that the clearance between the propeller blades and the baffle plate is as detailed in Table 3.

(5) Secure the shaft components with a plain washer\* (84) and self-locking nut\* (83). Before tightening check that marks made on each component during shaft concentricity check (para. 36) are in alignment. Tighten the nut. Check that the bearing surface of the shaft is running concentric within 0.002 in. total indicator reading.

(6) Re-position the bearing housing assembly (82), taking care not to damage the carbon bearing when locating it on the shaft. Secure to the casing with four 4BA cheese-head screws (77), spring washers (78) and plain washers (79). Before finally tightening these screws rotate the shaft and check that there is no interference between the propeller and slip ring. If satisfactory, tighten the screws and re-check.

**Note . . .**

*The carbon bearing and the bore of the slipring which form a part of the bearing housing assembly (82), are both machined after assembly. No attempt should be made to replace either component, and the assemblies should be returned to stores to be dealt with according to current authorized procedure.*

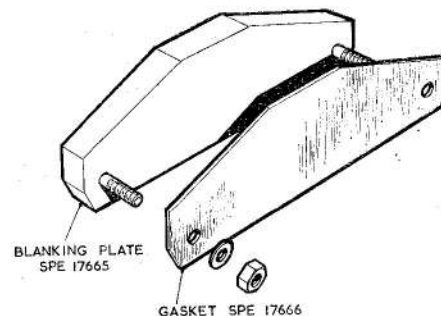

Fig. 28. Gland leakage pressure test tools

~~RESTRICTED~~

*Pressure testing for gland leakage*

42. (1) Fit the blanking plate SPE.17665 (fig. 28) and associated gasket SPE.17666 over the gland drain outlet, securing through two of the pump base/mounting plate fixing holes.
- (2) Fit a  $\frac{1}{2}$  in. dia. air hose as far as possible over the motor lead tube (109, fig. 7).
- (3) Gradually increase the applied air pressure from zero to 7 lb./in.<sup>2</sup>. Immerse the pump in a small tank of kerosene fuel and agitate until all trapped air has been displaced. Carefully examine the assembly for escaping air bubbles during a period of 5 minutes, particularly near the glands. Any leakage, however minute, must be eliminated before proceeding with the assembly of the pump.
- (4) If the gland leakage is minute, it may be possible to rectify the fault by running the motor unit to bed the gland seal faces. Remove the pump from the

tank. Run the pump at approximately 19V d.c. for 30 seconds. Stop for 30 seconds and then repeat the procedure three times. Disconnect the electrical supply, re-connect the air hose and repeat the pressure test. If the leakage still persists, dismantle the pump in accordance with instructions given in this chapter, re-lap the gland faces and re-assemble. If leakage shows up at the motor studs or top casing screws, replace the defective seal washer (14, fig. 7 or 34, fig. 4).

(5) When the pressure test has been satisfactorily completed, remove the blanking plate and the gasket.

*Assembling the mounting plate (fig. 7)*

43. (1) Check that all wire threads inserts are in position in the mounting plate (1). The casting must not be plugged or retapped if any of the insert tappings are faulty.
- (2) Lubricate and fit new seal rings (122 and 8) in the recessed seatings

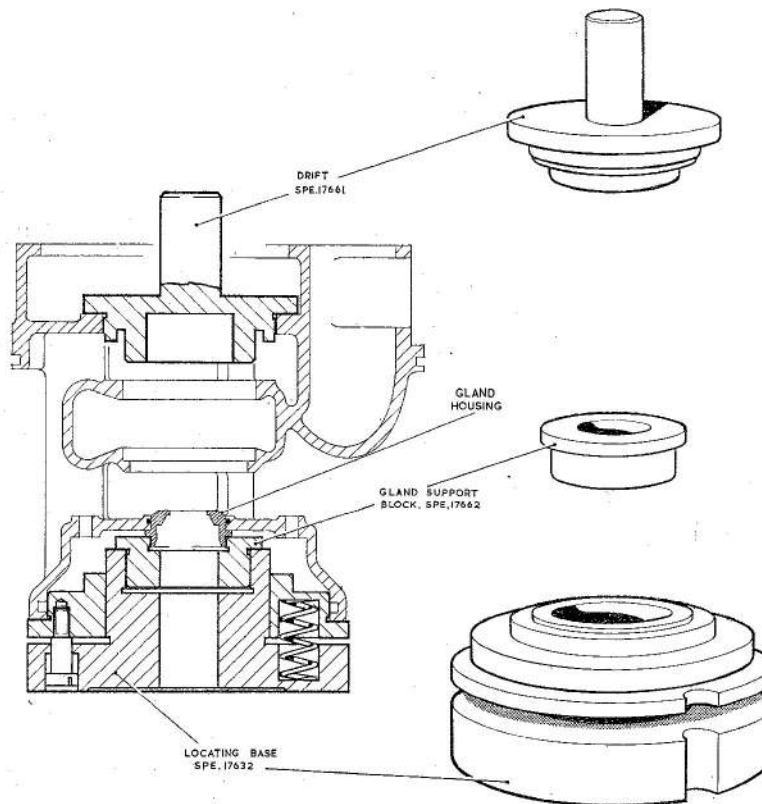

**Fig. 29. Tools for assembling the lower gland housing to the pump casing**

**RESTRICTED**

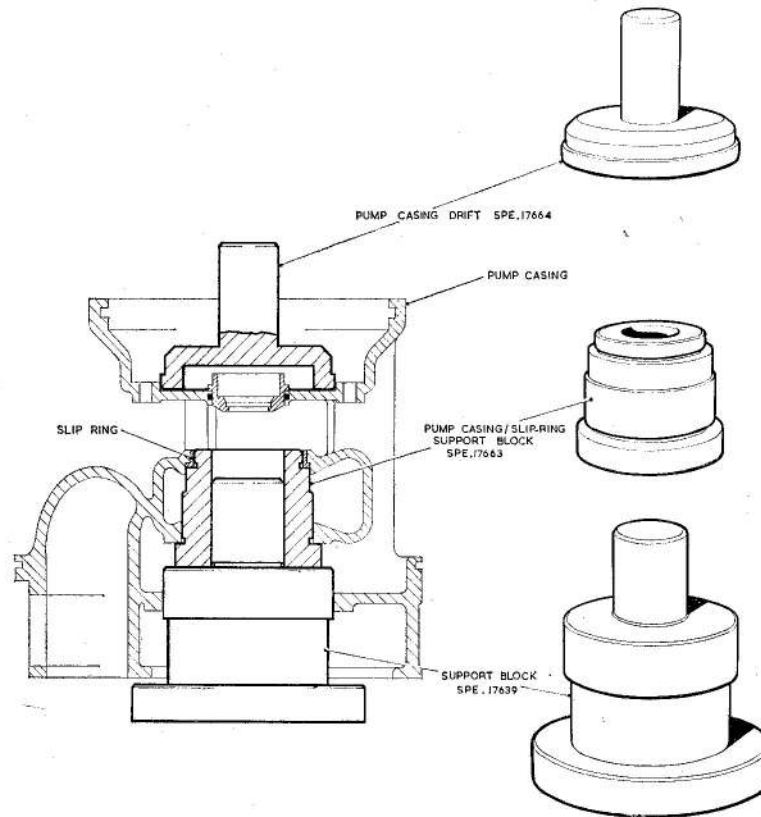

**Fig. 30. Tools for assembling the upper impeller slip-ring into the pump casing**

around the gland drain and delivery channels in the mounting plate.

(3) Smear the outside of the end of the motor lead tube (109) with Hermetite jointing compound. Position the mounting plate, aligning the gland drain, delivery and motor lead tube connections with the continuation channels in the pump casing. Secure the mounting plate to the pump casing with twelve 4BA hexagon head screws (75) and plain washers (76). Tighten diametrically opposite screws by degrees in turn.

*Assembling the suppressor box (fig. 7)*

44. (1) Check that the interior of the suppressor box is completely covered by insulation enamel to Spec. D.S.1278 except on the curved seatings for the suppression units and the resistor bolt clamping surface. Any other area where it has chipped away should be recovered with varnish.

(2) Smear the mating surfaces of the mounting plate (1) and suppressor box (87) with Hermetite jointing compound.

(3) Lubricate a new seal ring (108) with Silicone MS.4 grease, compound XG.250 and position over the end of the motor lead tube (109).

(4) Fit the suppressor box with the electrical connection mounting boss at the centre of the pump mounting plate (fig. 32). Secure with four hexagon-head screws (106) and seal washers (107).

(5) Fit the blanking plate SPE.17669 (fig. 31) and gasket SPE.17670 with four 6BA cheese-head screws (88), spring washers (89) and plain washers (90) to the suppressor box. Fit the blanking plate SPE.17667 and gasket SPE.17668 to the electrical connection tapping.

**RESTRICTED**

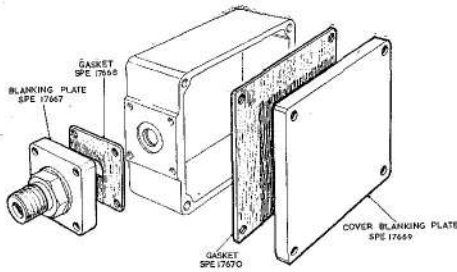
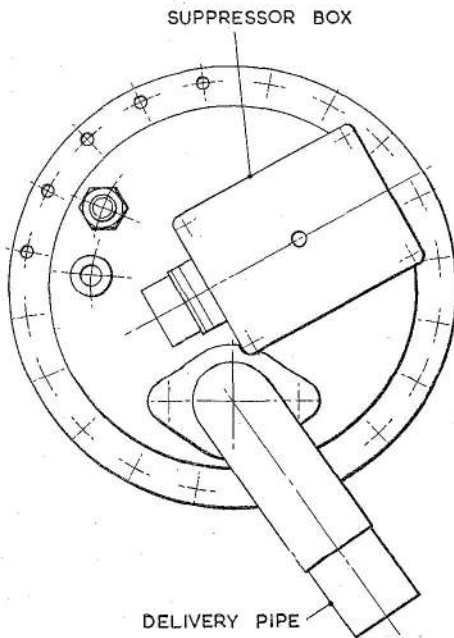

**Fig. 31. Tools for pressure testing the suppressor box/mounting plate joint**

(6) Fit a  $\frac{1}{4}$  in. B.S.P. plug into the gland drain tapping in the mounting plate.

(7) Connect an air line to the tapping of the electrical connection blanking plate SPE.17667. Gradually increase the applied air pressure from zero to 7 lb./in.<sup>2</sup>. Immerse the pump, including the suppression box, in a small tank of kerosine fuel and agitate until all trapped air has been displaced. Carefully examine the assembly for escaping air bubbles at the suppressor box/mounting plate joint. Leakage of air is not permissible.

(8) At the satisfactory conclusion of this test, remove the blanking plates and plug.



**Fig. 32. Alignment of the suppressor box and the delivery tube**

*Assembling the delivery pipe (fig. 7)*

45. (1) Lubricate a new seal ring (94) with Silicone MS.4 grease, compound XG.250 and position in the groove in the mounting plate.
- (2) Position the delivery pipe (95) as shown in Fig. 32 and secure with two hexagon head bolts (92) and plain washers (93).
- (3) Lock the screws with 22 S.W.G. non-corrodible steel wire.

*Assembling the suppression unit and electrical connection (fig. 10)*

46. (1) Trim the motor lead ZZ to 4 in. length from the base of the suppressor box. Turn back the rubber sleeve on the end of the lead and solder to the clip of the slider terminal of the resistor (143). Cover the soldered joint with the rubber sleeve.

**Note . . .**

*Use the resistor unit stamped with the same serial number as the motor unit. Do not move the slider terminal of the resistor as this has been pre-set during the speed setting of the motor unit.*

- (2) Turn back the rubber sleeve on the bare end of the lead assembly (136). Solder the lead to the end terminal of the resistor (143). Cover the soldered joint with the rubber sleeve unit.

- (3) Fit the resistor centre (139) through the bore of the resistor unit (143). Place a shakeproof washer (138) and a tufnol washer (140) on the resistor bolt (137). Insert the bolt through the bore of the resistor core, and fit a further washer (140), a shakeproof washer (138) and the self-locking nut (144). Screw the nut on the first few threads of the bolt only.

- (4) Cradle the resistor bolt in the two support lugs of the suppressor box casting, position the lugs between the shakeproof washer and the tufnol washer at each end of the assembly. Position the resistor (143) so that the terminal screws are inclined at between 45 and 60 degrees to the base of the suppressor box and tighten the nut (144).

**RESTRICTED**

(5) Trim the motor leads to the following dimensions from the base of the suppressor box:

Lead AZ—2.875 in. Lead AA—4.5 in. Bare the last half-inch of each lead. Cover each lead with a 4.0mm. i/dia. saturated glass sleeving pushing it down approximately half-an-inch into the end of the motor lead tube (109, fig. 7). Solder a terminal tag to each lead. Cover the soldered joint and trap the end of the saturated glass sleeving with a 1 in. rubber sleeve.

(6) Turn down the rubber sleeving on the untagged end of the lead assemblies (130 and 148) and solder them to two of the larger electrical plug pins. Ensure that these joints are not 'dry' soldered. Re-position rubber sleeves to cover the joints.

(7) Assemble the resistor fixed terminal lead (136, fig. 10) the longer of the two motor leads (AA) and the electrical plug/suppressor lead (130) to a capacitor (147) terminal and secure with a shakeproof washer and locknut (supplied with capacitor unit).

(8) Assemble the shorter of the two motor leads and the electrical plug/suppressor lead (148) to the second capacitor (147) and secure with a shakeproof washer and locknut.

(9) Position the two capacitor assemblies on the cast seatings in the suppressor box, arranging the leads in approximately the order illustrated in the key diagram of the suppressor assembly, (fig. 3). Fix the units in position with the clamp plate (131) and secure with a 4BA cheese-head screw (132), spring washer (133) and plain washer (134).

(10) Locate the electrical plug pins attached to the capacitor leads in position 1 and 2 of the electrical plug. Pins A and 3 are fitted but not connected. Assemble the plug with pins 1 and 2 nearest to the open end of the suppressor box. If a new plug is being fitted, two of the fixing screws supplied must be shortened by approximately  $\frac{1}{4}$  in. and used in the two tapped fixing positions. The two screws nearest the open end of the box are as supplied and

secured with shakeproof washers and locknuts.

(11) Fit a new gasket (86) on the suppressor box (87) and secure the lid (85) with four cheese-head screws (86), spring washers (89) and plain washers (90). Check that the 'Porosint' breather disc (142, fig. 7) is in position in the suppressor box lid.

#### *Re-assembling and fitting the by-pass valve assembly (fig. 7)*

47. (1) If the rubber valve face (4) is to be renewed, position a new rubber on the flap (10) and a cover plate (3) on the rubber. Secure with two rivets (5).

(2) Peen over one end of the valve hinge pin (11).

(3) Position the valve plate sub-assembly on the valve seat (2), insert the hinge pin through the fixing lugs at one end, engage the valve spring (12) and pass the pin through the opposite fixing lugs. Peen the end of the pin to retain. Check that the valve hinges freely.

#### **Note . . .**

*The valve spring should be assembled so that the long arm acts on the back of the valve, and the hook engages the right-hand hinge supports (when viewed on the valve flap (10) with the hinge in the bottom position).*

(4) Assemble the valve to the pump casing with four counter-sunk head screws (7) and shakeproof washers (6).

#### *Completing the assembly*

48. (1) Wire lock the screws (75, fig. 7) and (33, fig. 4) securing the pump casing to the mounting plate and the top casing to the motor unit.

(2) Fit the bottom suction strainer (74, fig. 7) over the pump casing. Flatten the strainer against the by-pass valve.

(3) Lubricate new seal rings (71, fig. 7) and (52, fig. 4) with Silicone MS.4 grease compound XG.250 and position one in the external groove in the pump casing (61, fig. 7) and one on the flange seating of the top casing (55, fig. 4).

**RESTRICTED**

(4) Fit the canister (57) squarely, taking care not to dislodge the seal rings. Secure with four 4BA cheese-head screws (35), spring washers (36) and plain washers (37).

(5) Replace the top suction strainer (43) and secure with four round-head screws (46), spring washers (47) and plain washers (48).

(6) Fit the gland drain cone adaptor (120, fig. 7) and bonded seal washer (121) and wire lock the assembly.

**Note . . .**

*This completes the assembly of the pump. If it is not to be immediately tested in accordance with the Schedule of Acceptance Tests (para. 51-59), the delivery outlet, electrical connection, gland drain and top and bottom suction strainer should be masked or plugged to prevent the ingress of dirt. Preferably enclose the complete pump in a polythene bag or similar packing, and store in a moisture free area away from excessive heat.*

**TESTING**

**General**

49. The completed pump should be tested in accordance with the Schedule of Tests detailed in para. 51-59. The pump should be rejected if it fails to comply with any one of these tests.

**Test equipment**

50. The universal fuel pump test rig is required to test this pump unit, and should contain Avtur fuel maintained at 20-25°C. A detailed description of the test rig and general information on the method of mounting the pump to the rig are given in A.P. 4343S, Vol. 1, Book 2, Sect. 10.

**Schedule of tests**

*Insulation resistance test*

51. Measure the insulation resistance between the pins of the electrical plug and frame using a 250V insulation resistance tester. The reading obtained should not be less than 2 megohms.

*Gland leakage test*

52. (1) With the pump fully submerged in fuel apply air pressure over the fuel at 16 lb./in.<sup>2</sup>.

(2) Set the input power supply to the pump to 29V d.c., close the flow regulating valve, switch on the power supply and run the pump for 15 mins. Whilst the pump is running observe for:

(a) External leakage of fuel; leakage is not permissible.

(b) Gland leakage; the maximum permissible leakage past the gland is 2 cc per hour with the pump running and 1 cc per hour when stationary.

(3) Where leakage is in excess of this amount the pump should be dismantled and the carbon seal faces re-lapped. Re-assemble the pump and repeat the test. After satisfactory completion of this test switch off the power supply, release the air pressure and open the fuel delivery valve.

*Starting test*

53. With the pump fully submerged in fuel and the input power supply to the motor adjusted to 18.5V d.c., check the starting operation of the pump motor by switching the supply ON and OFF several times. Unsatisfactory starting of the unit should be investigated and the fault rectified.

*Endurance test*

54. With a 6 in. head of fuel over the pump, switch on the power supply and run the pump in accordance to the figures quoted as follows:

(1) 26V d.c., 2400 g.p.h., 11 lb/in<sup>2</sup>+2  
-0

(2) 29V d.c., 2400 g.p.h., 11 lb/in<sup>2</sup>+2  
48A (max.) -0

55. Adjust the slider terminal of the resistor to obtain the first set of quoted figures. The pump should be rejected if any appreciable change in performance is observed other than that caused by the initial warming period.

*Calibration*

56. With a 6 in. head of fuel over the pump, adjust the flow regulating valve to obtain flows of 0-4000 g.p.h. in increments of 500 galls. Record the delivery pressure and motor current at each flow stage with the input power supply to the pump unit adjusted to 29, 26 and 22V d.c. Check also that the acceptance performance of the pump complies to the figures quoted as follows: 26V d.c., 2400 g.p.h., 11 lb/in<sup>2</sup>+2, 48A (max.)

~~RESTRICTED~~

*Dry test*

**57.** Remove the pump from the rig and run it dry for five minutes with the power supply to the motor adjusted to 29V d.c. The current consumption during this test should not exceed 15A.

**Note . . .**

*To avoid damage to the seal faces, the pump should be immersed in fuel prior to the 'dry test' or the test made immediately after the 'calibration test'.*

**58.** After completion of the 'dry test', switch OFF the supply and remove the supply lead from the pump unit.

*Final insulation resistance test*

**59.** Subject the pump unit to a further insulation resistance test whilst the unit is still warm (Refer to para. 51).

*Wire locking*

**60.** Ensure that all locking is correct and that lead seals are secure.

~~RESTRICTED~~



**Appendix 1****RECONDITIONING PDC 2400 DE Mk. 1 and 2 FUEL PUMPS****LIST OF CONTENTS**

	<i>Para.</i>		<i>Para.</i>
<i>General</i> ... ..	1	<b>Assembling</b>	
<b>Reconditioning</b>		<i>Detailed procedure</i> ... ..	4
<i>Tools and test equipment</i> ... ..	2	<b>Testing</b>	
<b>Dismantling</b>		<i>General</i> ... ..	5
<i>Detailed procedure</i> ... ..	3		

**LIST OF ILLUSTRATIONS**

	<i>Fig.</i>
<i>Tool for removing top and pump casings</i>	1

**General**

1. This appendix details the minor differences in the dismantling and re-assembly procedure for the PDC.2400 DE Mk.1 and 2 fuel pumps as compared with that given for the PDC.2400 DE Mk.4 fuel pumps in the basic chapter. It should be noted that although instructions are given for repairing PDC.2400 DE Mk.1 and 2 fuel pumps to their original standard, they should be rebuilt to incorporate relevant retrospective modifications.

**RECONDITIONING****Tools and test equipment**

2. All tools listed in Table 1 of the basic chapter are required for reconditioning the PDC.2400 DE Mk.1 and 2 pump with the exception of the spacing bush extractor (SPE.17642). Additionally the motor removal tool SPE.19549 is required to separate the pump and top casings from the motor unit.

**DISMANTLING****Detailed procedure**

3. Where no details are given under the stage headings in the following breakdown, refer to the equivalent paragraph and illustrations quoted in the dismantling instructions for the PDC.2400 DE Mk.4 pump in the basic chapter.

(1) Removing the canister and bottom suction strainer.

(2) Dismantling the suppressor box assembly: generally as for PDC.2400 DE Mk.4 but an earlier design of the suppressor clamp (131, fig. 10) is fitted and a shorter screw (132) used to secure it.

(3) Removing the delivery pipe.

(4) Removing the top suction strainer and vapour deflector.

(5) Detaching the mounting plate assembly: generally as for PDC.2400 DE Mk.4 but an earlier design of the mounting plate with a  $\frac{3}{16}$  in. diameter gland drain channel is fitted. No cone adaptor (120, fig. 7) and washer (121) are fitted.

(6) Removing and dismantling the bypass valve.

(7) Removing the lower bearing housing assembly.

(8) Dismantling the pump casing assembly: generally as for PDC.2400 DE Mk.4 but use the special tool

~~RESTRICTED~~

SPE.19549 (app. 1, fig. 1) to withdraw the pump casing (61, fig. 7) from the motor unit. Place the assembled tool around the motor unit so that the cut-outs in the centre and bottom bands give clearance to the heads of the nameplate screws. The centre band must be tightly clamped on to the motor. The lower band must be left sufficiently slack to enable it to move along the motor when the compression screws are turned. Turn the two screws which operate the bottom band, giving an equal number of turns to each screw alternately until the pump casing is clear of the motor unit. Note that the pump casing differs from the Mk.4 casing (61) in which the gland drain channel is  $\frac{3}{16}$  in. diameter and that no spacer is fitted between the rotary seal and the motor unit bearing. The shaft circlip retaining the bearing should not be removed.

(9) Dismantling the top casing: generally as for PDC.2400 DE Mk.4 but the special withdrawal tool SPE.19549 should be used to separate the casing from the motor unit. The method of using this tool is detailed in the preceding sub-para.

*Dismantling the motor unit*

(10) Removing the brushes: the brushes fitted to the Mk.1 pump are of

different material to those fitted to Mk.2 and Mk.4 pumps. The removal procedure is unaffected.

(11) Removing the commutator-end casting.

(12) Withdrawing the armature assembly: generally as for PDC.2400 DE Mk.4 but an earlier design of armature is fitted.

(13) Removing the drive-end bearing.

(14) Dismantling the commutator-end unit.

**ASSEMBLING**

**Detailed procedure**

4. Where no details are given under the stage headings in the following breakdown, refer to the equivalent paragraph and illustrations quoted in the assembly instructions for the PDC.2400 DE Mk.4 given in the basic chapter.

(1) Re-assembling the commutator-end casting unit: generally as for PDC.2400 DE Mk.4, but KCEG.11 brushes are used on Mk.1 units in place of the CM.9022 brush material used for the Mk.2 and Mk.4 brush.

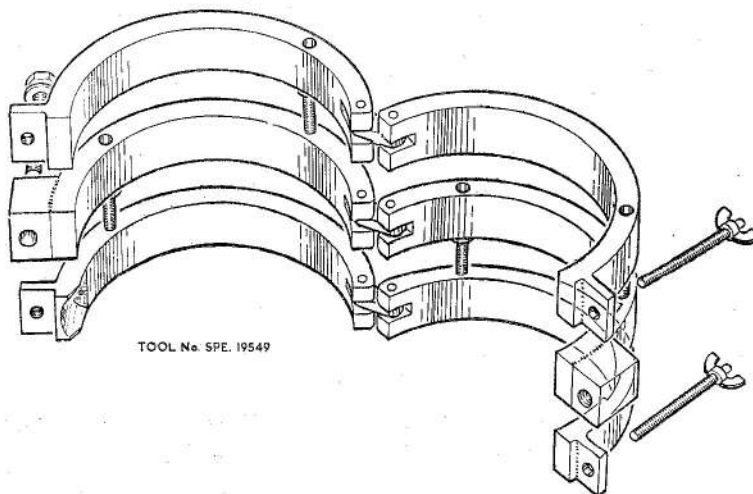

**Fig. 1. Tool for removing top and pump casings**

~~RESTRICTED~~

(2) Assembling the frame unit and armature: generally as for PDC.2400 DE Mk.4 but the later Mk.2 pumps are fitted with bearings lubricated with XG.250 grease and an armature of earlier design is fitted.

(3) Assembling the commutator-end casting unit and the frame unit and armature.

(4) Checking the motor shaft concentricity.

(5) Pre-bedding new brushes: on Mk.1 units use KCEG.11 brushes in place of (188, fig. 21).

#### *Pump unit*

(6) Concentricity check on assembled motor shaft.

(7) Assembling the top casing: generally as for PDC.2400 DE Mk.4 but use an earlier design of seal ring in place of (56, fig. 4) in the open end of the top casing. This seal ring is to be set in position with Hermetite jointing compound.

(8) Assembling the pump casing: generally as for PDC.2400 DE Mk.4 but use an earlier design of seal ring in place of (60, fig. 7) in the open end of the pump casing. This seal ring is to be set in position with Hermetite compound. The gland drain tube (124, fig. 4) is also of earlier design.

#### **Note . . .**

*Both the top and pump casings fitted to the Mk.1 and 2 pumps include  $\frac{3}{16}$  in. dia. gland drain channels as compared to the  $\frac{1}{4}$  in. dia. channel in the Mk.4 pump casing.*

(9) Pressure test for gland leakage.

(10) Assembling the mounting plate: generally as for PDC.2400 DE Mk.4 but an earlier design of the mounting plate with a  $\frac{3}{16}$  in. dia. gland drain channel is fitted.

(11) Assembling the suppressor box.

(12) Assembling the delivery pipe.

(13) Assembling the suppression units and electrical connection: generally as for PDC.2400 DE Mk.4 but all Mk.1 and some of the Mk.2 units are fitted with an earlier design of the suppressor clamp (131, fig. 10) secured by a shorter screw (132).

(14) Re-assembling and fitting the by-pass valve assembly.

(15) Completing the assembly. No cone adaptor and washer are fitted to the gland drain tapping in the mounting plate.

#### **TESTING**

##### **General**

5. Test equipment details and the Schedule of Acceptance Tests for PDC.2400 DE Mk.1 and 2 fuels pumps are similar to those given in the basic chapter for Mk.4 pumps.

~~RESTRICTED~~

C

C

C

C

## Appendix 2

# RECONDITIONING PDC.2400 DE MK. 3 FUEL PUMPS

### LIST OF CONTENTS

	<i>Para.</i>		
<i>General</i> ... ..	1	<b>Dismantling and Assembling</b>	
<b>Reconditioning</b>		<i>Detailed procedure</i> ... ..	3
<i>Tools and test equipment</i> ... ..	2	<b>Testing</b>	
		<i>General</i> ... ..	4

#### General

1. This appendix details the minor differences in the dismantling and re-assembling procedure for the PDC.2400 DE Mk.3 Fuel pump as compared with that given for PDC.2400 Mk.4 fuel pumps in the basic chapter. It should be noted that although instructions are given for repairing PDC.2400 DE Mk.3 pumps to their original standard, they should be re-built to incorporate relevant modifications.

#### RECONDITIONING

##### Tools and test equipment

2. All tools listed in Table 1 of the basic chapter are required for overhauling the PDC.2400 DE Mk.3 fuel pump. Additionally the motor removal tool SPE.19549 (app. 1, fig. 1) is required to separate the pump and top casings from the motor unit.

#### DISMANTLING AND ASSEMBLING

##### Detailed procedure

3. Where no details are given under the stage headings in the following breakdown, refer to the equivalent paragraph in the dismantling instructions for the PDC.2400 DE Mk.4 pump given in the basic chapter.

- (1) Removing the canister and bottom suction strainer.
- (2) Dismantling the suppressor box assembly.
- (3) Pre-bedding new brushes.

##### Pump unit

(4) Concentricity check on assembled motor shaft.

(5) Assembling the top casing: Generally as for PDC.2400 DE Mk.4 but use an earlier design of seal ring in place of (56, fig. 4) in the open end of the top casing. This seal ring is to be set in position with Hermetite jointing compound.

(6) Assembling the pump casing: Generally as for PDC.2400 DE Mk.4 but use an earlier design of seal ring in place of (60, fig. 7) in the open end of the pump casing. This seal ring is to be set in position with Hermetite jointing compound. The gland drain tube (124, fig. 4) is also of earlier design.

##### Note . . .

*Both the top and pump casings include a <sup>3</sup>/<sub>16</sub> inch diameter gland drain channel as compared to the <sup>1</sup>/<sub>4</sub> inch channel in the Mk.4 pump casing.*

- (7) Pressure test for gland leakage.
- (8) Assembling the mounting plate; Generally as for PDC.2400 DE Mk.4 but an earlier design of the mounting plate with a <sup>3</sup>/<sub>16</sub> inch diameter gland drain channel is fitted.
- (9) Assembling the suppressor box.

**RESTRICTED**

- (10) Assembling the delivery pipe.
- (11) Assembling the suppression units and electrical connection.
- (12) Re-assembling and fitting the bypass assembly.
- (13) Completing the assembly: No cone adaptor and washer are fitted to

the gland drain tapping in the mounting plate.

## TESTING

### General

4. Test equipment details and the Schedule of Acceptance Tests for PDC.2400 DE Mk.3 fuel pumps are similar to those given in the basic chapter for Mk.4 pumps.

~~RESTRICTED~~

This file was downloaded  
from the RTFM Library.

Link: [www.scottbouch.com/rtfm](http://www.scottbouch.com/rtfm)

Please see site for usage terms,  
and more aircraft documents.

