

Do not destroy

**Chapter 42**

**PUMPS, FUEL, SPE.2009 & SPE.2009A SERIES**

**LIST OF CONTENTS**

	Para.		Para.
Introduction ... ..	1	Assembling the brush gear ... ..	29
<b>Reconditioning</b>		Refitting the brush gear assembly to the commutator-end casing ... ..	30
Tools and test equipment ... ..	4	Assembling the armature to the drive-end casing ... ..	31
<b>Dismantling</b>		Assembling the drive-end casing sub-assembly to the stator and commutator-end casing assemblies	32
Separating the motor unit from the pump unit		Field lead positioning ... ..	33
General ... ..	5	Brush bedding ... ..	34
Separating and dismantling the lower base assembly ... ..	6	Motor torque test ... ..	35
Removing the impeller and impeller helix ... ..	7	Assembling the suppression assembly ... ..	36
Separating the motor unit from the upper base ... ..	8	Fitting the suppression sub- assembly to the motor unit ... ..	37
Dismantling the upper base assembly	9	Assembling the electric lead sub- assembly ... ..	38
Dismantling the motor unit		Miscellaneous ... ..	39
Removing the suppression assembly	10	<b>Pump unit</b>	
Dismantling the suppression network	11	Replacing the thrower unit ... ..	40
Removing the brushes ... ..	12	Fitting the upper base sub-assembly	41
Removing the armature and drive- end motor casing ... ..	13	Assembling the motor unit to the upper pump base ... ..	42
Separating the armature from the drive-end motor casing ... ..	14	Assembling the impeller helix ... ..	43
Separating the commutator-end motor casing from the stator assembly ... ..	15	Fitting the by-pass valve ... ..	44
Dismantling the commutator-end motor casing ... ..	16	Assembling the centrifugal impeller	45
Miscellaneous ... ..	17	Pressure testing the pump assembly	46
<b>Cleaning, Inspection &amp; Repair</b>		Assembling the lower base ... ..	47
Cleaning ... ..	18	Assembling the electrical connection	48
<b>Inspection</b>		Completing the pump assembly ... ..	49
General ... ..	22	Acceptance testing and wire locking	50
Detailed procedure ... ..	23	<b>Testing</b>	
Pre-bedding brushes ... ..	24	General ... ..	51
Rhodium plating the commutator	25	Test equipment ... ..	52
<b>Assembling</b>		Schedule of tests	
General ... ..	26	Gland leakage test ... ..	53
<b>Motor unit</b>		Starting test ... ..	55
Assembling the drive-end bearing	27	Endurance test ... ..	56
Assembling the commutator-end bearing ... ..	28	Calibration test ... ..	57
		Dry test ... ..	58
		Bonding ... ..	59
		Insulation resistance test ... ..	60

~~RESTRICTED~~

## LIST OF TABLES

	Table		Table
<i>Special tools and equipment ...</i>	1	<i>Endurance test ...</i>	4
<i>Detailed inspection of components ...</i>	2	<i>Calibration test (normal speed) ...</i>	5
<i>Schedule of fits, clearances and repair tolerances ...</i>	3	<i>Calibration test (high speed) ...</i>	6
		<i>Faults, possible cause and remedies</i>	7

## LIST OF ILLUSTRATIONS

	Fig.		Fig.
<i>Sectional view of pump ...</i>	1	<i>Exploded view of terminal assembly (suppression unit) ...</i>	9
<i>Sectional view of suppression assembly</i>	2	<i>Circuit diagram : SPE.2009 series pumps ...</i>	10
<i>Sectional view of brush gear and bypass valve assemblies ...</i>	3	<i>Assembly of thrower nut/carbon gland seat ...</i>	11
<i>Exploded view of pump unit ...</i>	4	<i>Tools for positioning the bellows gland sub-assembly ...</i>	12
<i>Exploded view of motor unit ...</i>	5	<i>Alignment and centralising gauges ...</i>	13
<i>Exploded view of suppression unit assembly ...</i>	6	<i>Tools for pressure testing the pump assembly ...</i>	14
<i>Removal and replacement of the upper bearing sleeve ...</i>	7		
<i>Fits and clearance diagrams ...</i>	8		

## LIST OF APPENDICES

	App.
<i>Reconditioning the mounting plate assembly for SPE.2009 and SPE.2009A series pumps ...</i>	1
<i>Reconditioning SPE.2009 Mk.4 fuel pumps ...</i>	2
<i>Reconditioning SPE.2009A Mk.4 and 5 fuel pumps ...</i>	3

~~RESTRICTED~~

**Introduction**

1. A general description of the SPE.2009 series fuel booster pump is given in A.P.4343D, Vol. 1, Book 2, Sect. 7. Details of the differences between the various mark numbers are given in appendices to the general chapter. Reconditioning instructions are given in the present chapter for the SPE.2009 Mk. 5 fuel pump, with appendices covering the differences in procedure for any earlier or later pumps in the series and also for SPE.2009A series pumps.

2. The pump assembly comprises a 26V d.c. motor unit driving an impeller system carried on the extended armature shaft. Fuel is prevented from entering the motor unit by a metallic bellows type gland and by a thrower ring incorporating a labyrinth type seal. The pump electrical circuit includes a radio-interference suppression network.

3. The complete pump is normally assembled to a mounting plate which is secured to a bolt ring in the aircraft fuel tank. Although this mounting plate forms

part of the pump assembly as originally supplied it is often left in the aircraft during a pump change. SPE.2009 series pumps are therefore frequently returned for repair without the mounting plate attached. Overhaul of the mounting plate is covered in Appendix 1 to this chapter..

**RECONDITIONING****Tools and test equipment**

4. In addition to the standard bench tools, the special tools listed in Table 1 or their equivalents are required to overhaul the SPE.2009 Mk. 5 fuel pump. Details of the Universal Fuel Pump Test Rig which should be used to test these pumps, will be issued as soon as the information is available and will be found in A.P.4343S, Vol. 1, Book 2, Sect. 10.

**Note . . .**

*Tools illustrated in this chapter may differ in minor details from those available, but the basic method of application is as shown.*

**TABLE 1****Special tools and equipment**

Nomenclature	Part Number	Fig. No.	Ref. No.
Universal, fuel pump test rig			5G/3494
Thrower nut C-spanner	SPE.15093		
Bearing pad	SPE.15094	8	
Locating bush and pin			
	Bearing sleeve		
	removal and assembly	8	
Calibration fan	SPE.14578		
Collar	SPE.16007	11	
Setting pin			
	Thrower nut		
	assembly	11	
Setting block	SPE.17321	11	
	positioning part of		
Weight	SPE.17287	12	
	Bellows gland		
Gauge stand assembly	SPE.17321	12	
	positioning		
Vapour guide cone centralising gauge	SPE.19546	13	
Motor unit alignment gauge	SPE.19545	13	
Blanking plate	SPE.17412	14	
	Pressure test		
Blanking plate gasket	SPE.17413	14	
	tools		

**RESTRICTED**

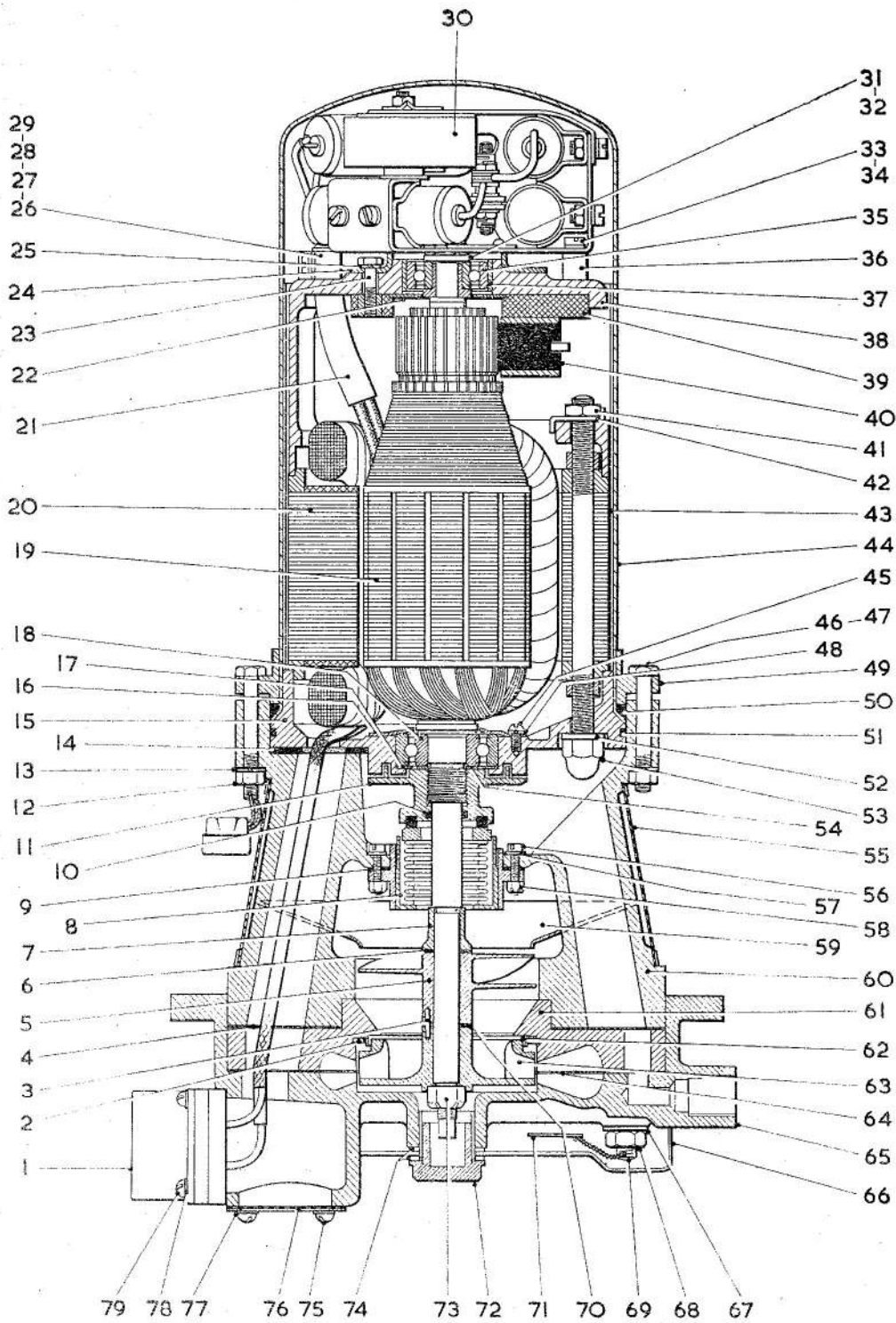

Fig. 1. Sectional view of pump

**RESTRICTED**

## Key to Fig. 1

1 ELECTRICAL CONNECTION	41 TIE-BOLT LOCKNUT
2 CIRCLIP (FLOATING IMPELLER SEAL RETAINING)	42 LOCK WASHER
3 DOWEL FIN	43 CORRUGATED COOLING SHIELD
4 PAPER WASHER (VOLUTE PLATE/UPPER BASE)	44 MOTOR CASING
5 IMPELLER HELIX	45 RD. HD. SCREW (BEARING RETAINER PLATE SECURING)
6 SHIM (HELIX SPACING)	46 CLAMPING BOLT (PLAIN)
7 SPACER	47 DRILLED CLAMPING BOLT
8 BELLOWS GLAND HOUSING SUB-ASSEMBLY	48 SHAKEPROOF WASHER (BEARING RETAINER PLATE SECURING)
9 SHIM WASHER (GLAND HOUSING POSITIONING)	49 CLAMPING BOLT RING
10 SEAL RING (THROWER ASSEMBLY)	50 MOTOR CASING SEAL RING
11 THROWER NUT	51 COMMUTATOR-END CASING JOINT RING
12 LOCKNUT                    MOTOR UNIT	52 SEAL WASHER
13 SPRING WASHER            CLAMPING	53 DOME NUT
14 CABLE INLET SEAL WASHER	54 SHIM (THROWER NUT ADJUSTING)
15 COMMUTATOR-END MOTOR CASING	55 INLET FILTER
16 BEARING RETAINER PLATE	56 CH. HD. SCREW (6BA)                    } GLAND
17 DUST SHIELD (DRIVE-END BEARING)	57 SEAL WASHER (6RA)                    } HOUSING
18 DRIVE-END BEARING	58 SELF LOCKING NUT (6BA)                } SECURING
19 ARMATURE ASSEMBLY	59 VAPOUR GUIDE CONE
20 STATOR ASSEMBLY	60 UPPER BASE
21 LEAD ASSEMBLY	61 VOLUTE PLATE
22 COMMUTATOR-END DUST SHIELD	62 FLOATING IMPELLER SEAL WASHER
23 HEX HD. SCREW (BRUSH BOX RETAINING)	63 CENTRIFUGAL IMPELLER
24 BEARING COVER PLATE	64 PAPER GASKET
25 SPRING WASHER	65 LOWER BASE
26 CLAMP BLOCK	66 BASE COVER
27 CLAMP PLATE	67 SPRING WASHER LOWER BASE
28 SHAKEPROOF WASHER	68 LOCKNUT SECURING
29 CH HD. SCREW	69 DRILLED STUD
30 SUPPRESSION SUB-ASSEMBLY	70 SHIM (CENTRIFUGAL IMPELLER ADJUSTING)
31 PLAIN WASHER	71 SEAL
32 SELF-LOCKING NUT                    } SUPPRESSION	72 BASE COVER PLUG
33 CH. HD. SCREW                        } ASSEMBLY SECURING	73 SHAFT SELF-LOCKING NUT
34 SHAKEPROOF WASHER	74 PLAIN WASHER
35 COMMUTATOR-END BEARING	75 RD. HD. SCREW (FIREPROOF COVER SECURING)
36 SPACER	76 FIREPROOF COVER
37 COMMUTATOR-END BEARING SLEEVE	77 SHAKEPROOF WASHER (FIREPROOF COVER SECURING)
38 COMMUTATOR-END CASING	78 SHAKEPROOF WASHER                    } ELECTRICAL
39 BRUSH GEAR ASSEMBLY	79 RD. HD. SCREW                        } CONNECTION
40 BRUSH AND TAG ASSEMBLY	

**RESTRICTED**

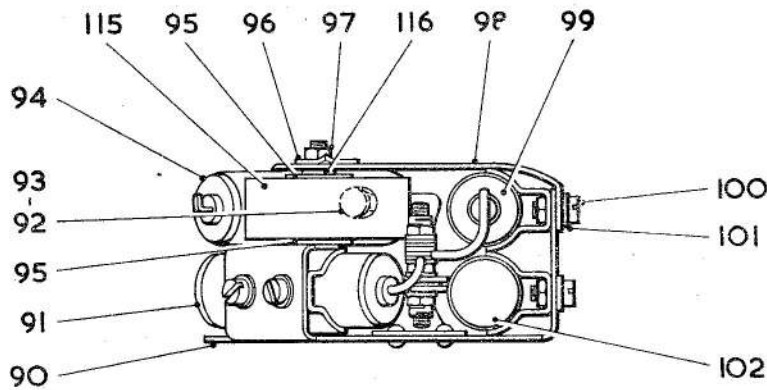

SUPPRESSOR ASSEMBLY

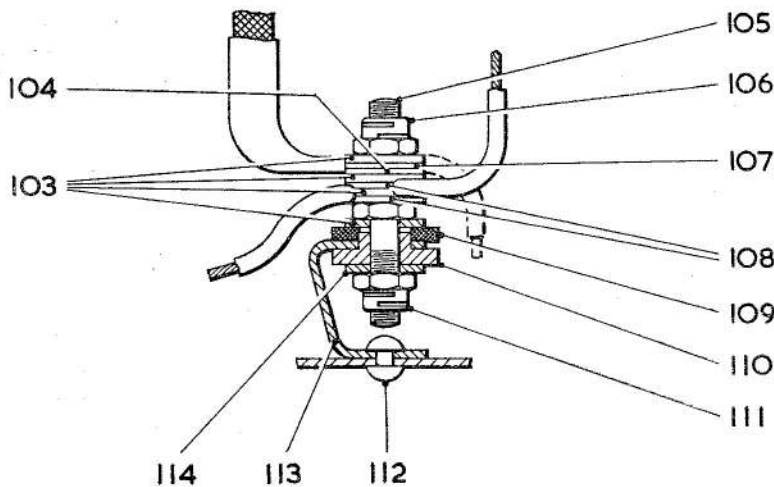

TERMINAL ASSEMBLY  
(SUPPRESSION NETWORK)

- |                                |                                |
|--------------------------------|--------------------------------|
| 90 SUPPRESSION BRACKET         | 103 PLAIN WASHER (4 BA)        |
| 91 CAPACITOR (TYPE 335/64A/1)  | 104 TAG (INDUCTOR UNIT LEAD)   |
| 92 LOCKNUT (4 BA)              | 105 TERMINAL POST              |
| 93 SHAKEPROOF WASHER           | 106 SELF-LOCKING NUT (4 BA)    |
| 94 CAPACITOR (TYPE 335/668/1)  | 107 TAG (MOTOR UNIT LEAD)      |
| 95 MICA WASHER                 | 108 TAG (CAPACITOR LEAD)       |
| 96 TAG WASHER                  | 109 TERMINAL INSULATION WASHER |
| 97 LOCKNUT (4 BA THIN)         | 110 TERMINAL INSULATION BUSH   |
| 98 ANTI-VIBRATION STRUT        | 111 SELF-LOCKING NUT (4 BA)    |
| 99 CAPACITOR (TYPE 4774 A/2)   | 112 SNAP HEAD RIVET            |
| 100 CH. HD. SCREW              | 113 TERMINAL BRACKET           |
| 101 SHAKEPROOF WASHER          | 114 PLAIN WASHER               |
| 102 CAPACITOR (TYPE 335/64A/1) | 115 INDUCTOR UNIT ASSEMBLY     |
|                                | 116 PLAIN WASHER               |

Fig. 2. Sectional view of suppression assembly

**RESTRICTED**

**DISMANTLING**

(The numbers in brackets refer to the illustration quoted, following the paragraph heading, unless otherwise indicated).

**Separating the motor unit from the pump unit**

General (fig. 4)

5. (1) Remove the locking wire and cheese-head screws (134), securing the filter assembly (55). Withdraw the filter.
- (2) Cut the locking wire securing the base cover retaining plug (72). Remove the plug and withdraw the base cover (66) and the two joint washers (74).
- (3) Cut the locking wires to the seals on the upper base stud (69) and the clamping bolt (47, fig. 5).
- (4) Detach the electrical connection (1) by removing the four screws (79) and shakeproof washers (78). Withdraw the plug as far as the electrical leads will allow and unsolder the leads to the pins.

Separating and dismantling the lower base assembly (fig. 4)

6. (1) Remove the seven nuts (68) and spring washers (67).
- (2) Tap the lower base (65) assembly free of the upper base studs using a hide-faced hammer. Ignore any damage to the washer (64).
- (3) Remove the four 6BA round-head screws (75) and shakeproof washers (77) securing the fireproof cover assembly (76) to the base.
- (4) Cut the locking wire to the  $\frac{3}{4}$  in. B.S.P. drain plug (146). Remove the plug and the bonded seal washer (145).

Removing the impeller and impeller helix (fig. 4)

7. (1) Remove the spindle end nut (73) and withdraw the impeller (63) with shims (70). Use a spanner on the flats of the armature spindle to prevent rotation.

(2) Remove the three cheese-head screws (143) and spring washers (142) securing the volute plate (61) to the upper base assembly.

(3) Prise off the volute plate, ignoring damage to any paper gaskets (4) fitted.

(4) Tap out the by-pass seating (132) and extract the by-pass valve plate (144).

(5) Release the impeller seal ring circlip (2) and remove the impeller floating seal (62).

(6) Withdraw the impeller helix (5) from the armature spindle together with any shims (6) fitted. Remove the distance piece (7).

Separating the motor unit from the upper base (fig. 5)

8. (1) Unscrew and remove the twelve motor unit clamping bolts (46—11 off: 47—1 off) together with nuts (12) and spring washers (13).
- (2) Withdraw the clamping bolt ring (49), the light alloy motor casing (44) and the joint ring (50).
- (3) Extract the corrugated stator cooling shield (43) from the outer casing.
- (4) Withdraw the motor unit from the upper base, taking special care not to damage the bellows unit convolutions when withdrawing the shaft through it. Protect the motor unit spindle from damage.

Dismantling the upper base assembly (fig. 4)

9. (1) Unscrew and remove the five self-locking nuts (141).
- (2) Withdraw the five screws (135—2 off: 136—2 off: 137—1 off) and the spacing bushes (139—4 off: 140—1 off) together with the washers (138) securing the vapour guide cone through the spacing bushes to the base.
- (3) Remove the six self-locking nuts (58) securing the bellows sub-assembly (8) to the base. Withdraw the cheese-head screws (56) and sealing washers (57).

**RESTRICTED**

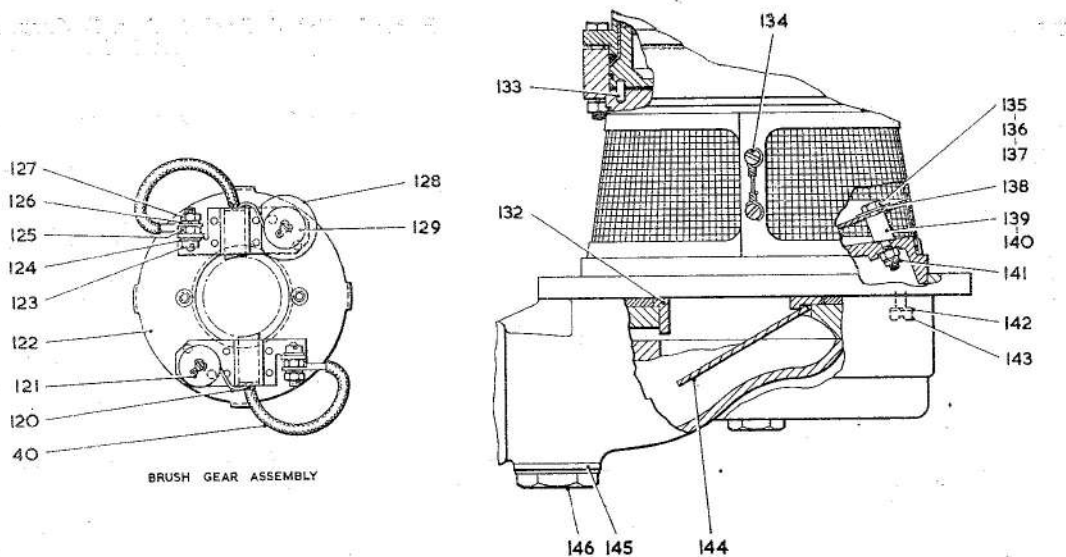

- |  |                                     |                                       |
|--|-------------------------------------|---------------------------------------|
| 40 BRUSH AND TAG ASSEMBLY              | 135 HEX. HD. SREW (4 BA x 1 IN.)    | } VAPOUR<br>GUIDE<br>CONE<br>SECURING |
| 120 BRUSH SPRING                       | 136 HEX. HD. SCREW (4 BA x 0.9 IN.) |                                       |
| 121 SPLIT PIN (1/16 IN. DIA. X 1/4 IN) | 137 HEX. HD. SCREW (4 BA x 0.8 IN.) |                                       |
| 122 BRUSH HOLDER AND CARRIER SUB-ASSY. | 138 PLAIN WASHER (4 BA)             | } VAPOUR GUIDE<br>CONE SUPPORTS       |
| 123 CH. HD. SCREW (4 BA)               | 139 SPACING BUSH (LONG)             |                                       |
| 124 SHAKEPROOF WASHER                  | 140 SPACING BUSH (SHORT)            | } VOLUTE PLATE<br>FIXING              |
| 125 LOCKNUT (4 BA)                     | 141 SELF-LOCKING NUT                |                                       |
| 126 SPRING WASHER (4 BA)               | 142 SPRING WASHER (2 BA)            | } BY-PASS VALVE PLATE<br>FIXING       |
| 127 LOCKNUT (4 BA)                     | 143 CH. HD. SCREW (2 BA)            |                                       |
| 128 LEAD DISTANCE WASHER               | 144 BY-PASS VALVE PLATE             |                                       |
| 129 BRUSH SPRING LOCATING WASHER       | 145 SEAL WASHER                     |                                       |
| 132 BY-PASS VALVE SEAT                 | 146 DRAIN PLUG (3/4 IN. B.S.P)      |                                       |
| 133 DOWEL (MOTOR UNIT LOCATION)        |                                     |                                       |
| 134 CH. HD. SCREW (FILTER SECURING)    |                                     |                                       |

**Fig. 3. Sectional view of brush gear and by-pass valve assemblies**

(4) Withdraw the bellows housing sub-assembly. Use two 6BA screws in the extraction holes to assist in breaking the seal. Remove the shim gaskets (9).

(5) Remove the cable inlet gasket (14).

(6) Do not remove the base casting studs (80—2 off; 81—2 off; 69—1 off) unless necessary due to damage.

(7) Do not attempt to remove the bellows unit from the housing.

#### **Dismantling the motor unit**

##### *Removing the suppression assembly (fig. 5)*

10. (1) Remove the cheese-head screws (29) and shakeproof washers (28) securing the earthing clamp (27) to the clamp block (26).

(2) Disconnect all soldered and tag connections between the motor leads and the suppression network.

(3) Remove the three cheese-head screws (33) and shakeproof washers (34) freeing the suppression assembly (30) together with the clamp block (26) and two distance pieces (36).

##### *Dismantling the suppression network (fig. 6)*

11. (1) The individual capacitors (91, 99 and 102—1 off; 94—2 off) can be removed by unscrewing and removing the two screws (100) and shakeproof washers (101) securing each unit to the bracket (90) and releasing the tag from the appropriate terminal.

(2) The inductor unit assembly (115) can be removed by straightening the

**RESTRICTED**

ear of the locking washer (96) and removing the locknut (97) and anti-vibration strut (98). Disconnect the terminal connections.

(3) Each terminal is insulated from the supporting bracket (113) by two mating bushes (109 and 110). Remove these bushes if necessary by dismantling the terminal connections.

#### *Removing the brushes (fig. 5)*

12. (1) Withdraw the split pins (121), holding the brush spring assemblies in position.

(2) Withdraw the locating washer (129) brush springs (120), a further washer (129), and from one spindle the lead spacing washer (28).

(3) Remove the nuts (127) and spring washers (126) securing the brush tags to the carrier terminals.

(4) Mark each brush and identify it with the brush box in which it is fitted, before withdrawing the brushes.

#### *Removing the armature and drive-end motor casing (fig. 5)*

13. (1) Holding the thrower assembly (11) with the special C-spanner, unscrew the spindle end nut (32) and remove the washer (31).

(2) Cut the locking wire between the two dome nuts (53). Remove these nuts and the seal washers (52) securing the drive-end motor casing (15) to the stator assembly tie bolts.

(3) Withdraw the armature with the drive-end motor casing attached. Use a hide-faced hammer to tap the armature free of the upper bearing. Take particular care to ensure that the armature is not damaged on the brush boxes.

#### *Separating the armature from the drive-end motor casing (fig. 5)*

14. (1) Using the special C spanner unscrew and remove the thrower assembly (11). Extract the seal ring (10) and remove any shims (54).

(2) Withdraw the armature from the bore of the bearing (18).

(3) Dismantle the drive-end motor casing by removing the three round head screws (45) and spring washers (48) to remove the bearing retainer plate (16).

(4) Press the bearing (18) and dust shield (17) from the housing.

(5) Extract the seal ring (51) from the rim of the casing.

#### *Separating the commutator-end motor casing from the stator assembly (fig. 5)*

15. (1) Straighten the lock washer tangs (42) and remove the nuts (41) and washers.

(2) Withdraw the commutator-end motor casing assembly over the stator assembly tie-bolts.

#### *Dismantling the commutator-end motor casing (fig. 5)*

16. (1) Carefully mark the position of the brush box assembly (39) relative to the commutator-end motor casing (38).

(2) Unscrew the two screws (23) and remove with the spring washers (25) and commutator-end bearing cover (24). Remove the brush box assembly (39) together with the dust shield (22).

(3) Press out the bearing (35) and sleeve (37).

(4) Separate the bearing and sleeve using the special tools illustrated in Fig. 8.

#### *Miscellaneous (fig. 5)*

17. (1) Withdraw the electric lead sub-assembly (21), through the stator assembly.

(2) Do not attempt to detach the field coils from the laminated stator assembly.

### **CLEANING, INSPECTION AND REPAIR**

#### **Cleaning**

18. Immerse the armature and field assembly in white spirit. Clean all metal parts with a piece of linen. Dislodge carbon deposits using a pencil type soft bristle brush

~~RESTRICTED~~

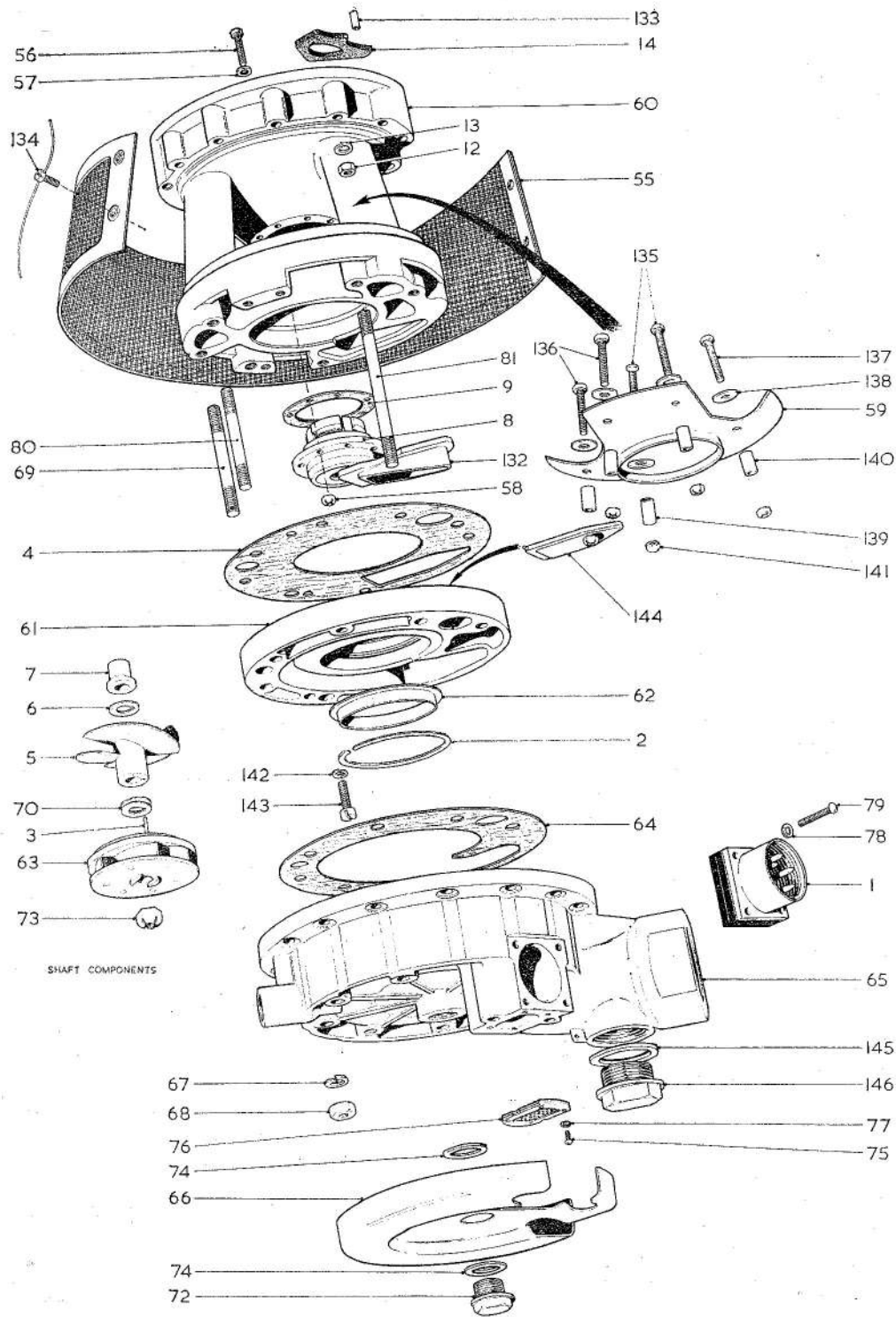

Fig. 4. Exploded view of pump unit

**RESTRICTED**

## Key to Fig. 4

1	ELECTRICAL CONNECTION	
2	CIRCLIP (FLOATING IMPELLER SEAL RETAINING)	
3	DOWEL PIN	
4	PAPER WASHER (VOLUTE PLATE/UPPER BASE)	
5	IMPELLER HELIX	
6	SHIM (HELIX SPACING)	
7	SPACER	
8	BELLOWS GLAND HOUSING SUB-ASSEMBLY	
9	SHIM WASHER (GLAND HOUSING POSITIONING)	
12	LOCKNUT	} MOTOR UNIT CLAMPING
13	SPRING WASHER	
14	CABLE INLET SEAL WASHER	
55	INLET FILTER	
56	CH. HD. SCREW (6 BA)	} GLAND HOUSING SECURING
57	SEAL WASHER (6 BA)	
58	SELF-LOCKING NUT (6 BA)	
59	VAPOUR GUIDE CONE	
60	UPPER BASE	
61	VOLUTE PLATE	
62	FLOATING IMPELLER SEAL WASHER	
63	CENTRIFUGAL IMPELLER	
64	PAPER GASKET	
65	LOWER BASE	
66	BASE COVER	
67	SPRING WASHER	} LOWER BASE SECURING
68	LOCKNUT	
69	DRILLED STUD	
70	SHIM (CENTRIFUGAL IMPELLER ADJUSTING)	
72	BASE COVER PLUG	
73	SHAFT SELF-LOCKING NUT	
74	PLAIN WASHER	
75	RD. HD. SCREW (FIREPROOF COVER SECURING)	
76	FIREPROOF COVER	
77	SHAKEPROOF WASHER (FIREPROOF COVER SECURING)	
78	SHAKEPROOF WASHER (6 BA)	} ELECTRICAL CONNECTION SECURING
79	RD. HD. SCREW (6 BA)	
80	UPPER BASE STUD (2.1 IN. LONG)	
81	UPPER BASE STUD (3.1 IN. LONG)	
132	BY PASS VALVE SEAT	
133	DOWEL (MOTOR UNIT LOCATION)	
134	CH. HD. SCREW (FILTER SECURING)	
135	HEX. HD. SCREW (4 BA x 1 IN.)	} VAPOUR GUIDE CONE SECURING
136	HEX. HD. SCREW (4 BA x 0.9 IN.)	
137	HEX. HD. SCREW (4 BA x 0.8 IN.)	
138	PLAIN WASHER (4 BA)	
139	SPACING BUSH (LONG)	} VAPOUR GUIDE CONE SUPPORTS
140	SPACING BUSH (SHORT)	
141	SELF-LOCKING NUT (4 BA)	
142	SPRING WASHER (2 BA)	} VOLUTE PLATE FIXING
143	CH. HD. SCREW (2 BA)	
144	BY-PASS VALVE PLATE	
145	SEAL WASHER	
146	DRAIN PLUG (½ IN. B.S.P.)	

and remove carbon and surplus spirit with dry compressed air. Allow to dry off for several hours. Complete drying in a ventilated oven at approximately 105°C.

19. Ensure that all jointing compound is removed from mating pump component surfaces, using an approved remover if necessary. All components except bearings, seal rings, brushes, capacitors and the electrical connection should be cleaned in an approved cleaning solvent, or if excessively dirty, in a heavy duty degreasant. After cleaning, blow off surplus solvent, allow to dry off for 12 hours and complete drying in a ventilated oven at approximately 105°C.

20. The ball bearing journals fitted to this pump unit are of the pre-packed, shielded type and should under normal conditions last between inspection periods when they should be renewed.

21. Synthetic rubber components should be replaced with new on re-assembly. If it is absolutely necessary to re-use such a component, it must only be cleaned in lead-free gasoline—not trichlorethylene or any similar degreasant.

### Inspection

#### General

22. Inspect all metal components for cleanliness, distortion, cracking (visual), scoring, denting, visual evidence of wear, deterioration of protective finishes (corrosion), serviceability of threads, security of sub-assemblies not dismantled (e.g. riveting) and discoloration due to overheating. Examine re-usable rubber components and electrical cable insulation for cleanliness, chafing, cracking, cuts, overheating, fluid soakage and general deterioration. All seal rings must be re-newed on re-assembly.

**RESTRICTED**

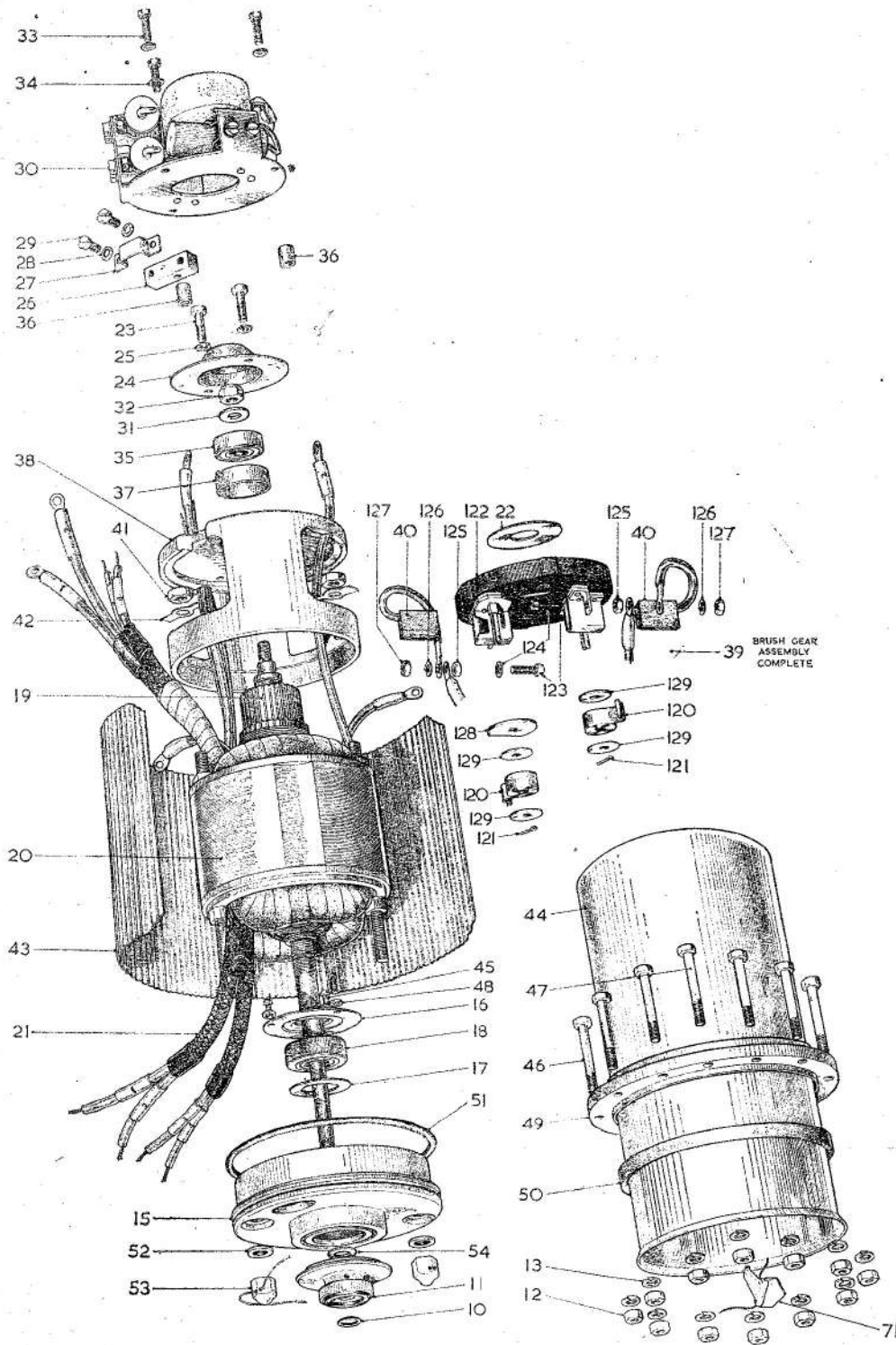

Fig. 5. Exploded view of motor unit

**RESTRICTED**

## Key to Fig. 5

10 SEAL RING (THROWER ASSEMBLY)	38 COMMUTATOR-END CASING
11 THROWER NUT	39 BRUSH GEAR ASSEMBLY
12 LOCKNUT	40 BRUSH AND TAG ASSEMBLY
13 SPRING WASHER } MOTOR UNIT CLAMPING	41 TIE-BOLT LOCKNUT
15 COMMUTATOR-END MOTOR CASING	42 LOCKWASHER
16 BEARING RETAINER PLATE	43 CORRUGATED COOLING SHIELD
17 DUST SHIELD (DRIVE-END BEARING)	44 MOTOR CASING
18 DRIVE-END BEARING	45 RD. HD. SCREW (BEARING RETAINER PLATE SECURING)
19 ARMATURE ASSEMBLY	46 CLAMPING BOLT (PLAIN)
20 STATOR ASSEMBLY	47 DRILLED CLAMPING BOLT
21 LEAD ASSEMBLY	48 SHAKEPROOF WASHER (BEARING RETAINER PLATE SECURING)
22 COMMUTATOR-END DUST SHIELD	49 CLAMPING BOLT RING
23 HEX. HD. SCREW (BRUSH BOX RETAINING)	50 MOTOR CASING SEAL RING
24 BEARING COVER PLATE	51 DRIVE-END CASING JOINT RING
25 SPRING WASHER	52 SEAL WASHER
26 CLAMP BLOCK	53 DOME NUT
27 CLAMP PLATE	54 SHIM (THROWER NUT ADJUSTING)
28 SHAKEPROOF WASHER	120 BRUSH SPRING
29 CH. HD. SCREW	121 SPLIT PIN (1/16 IN DIA. X 1/2 IN.)
30 SUPPRESSION SUB-ASSEMBLY	122 BRUSH HOLDER AND CARRIER ASSEMBLY
31 PLAIN WASHER	123 CH. HD. SCREW (4BA) } BRUSH BOX
32 SELF-LOCKING NUT	124 SHAKEPROOF WASHER } TERMINAL
33 CH. HD. SCREW } SUPPRESSION ASSEMBLY SECURING	125 LOCKNUT (4BA) }
34 SHAKEPROOF WASHER } SUPPRESSION ASSEMBLY SECURING	126 SPRING WASHER (4BA) } BRUSH TAG
35 COMMUTATOR-END BEARING	127 LOCKNUT (4BA) } SECURING
36 SPACER	128 LEAD DISTANCE WASHER
37 COMMUTATOR-END BEARING SLEEVE	129 BRUSH SPRING LOCATING WASHER

*Detailed procedure*

23. Parts should be inspected in accordance with Table 2 and checked for conformity with the Schedule of fits, clearances and repair tolerances given in Table 3. A general chapter on the lapping procedure for mechanical seals fitted to fuel pumps, will be issued as soon as the information is available and will be found in A.P.4343, Vol. 6.

*Pre-bedding brushes*

24. It will be necessary to pre-bed new brushes, or the original brushes when re-fitted after commutator skimming. Detailed procedure for pre-bedding brushes is given in A.P.4343, Vol. 1, Sect. 1. To avoid repetition this procedure is not given in the assembly instructions for this pump motor and should be allowed for at the appropriate assembly stage.

*Rhodium plating the commutator*

25. The commutator of a reconditioned armature must be rhodium plated by the 'Dalic' process after skimming. The procedure is as follows:

- (1) Mask the areas of the armature which do not need to be plated using non-absorbent cellulose masking tape (1 in. wide).
- (2) Clean the commutator with trichlorethylene.
- (3) Clean the commutator with aluminium oxide 1800 mixed to paste form in water.
- (4) Wash the commutator with cold water.
- (5) Connect the armature to the 'Dalic' plating set at 12 volts normal

~~RESTRICTED~~

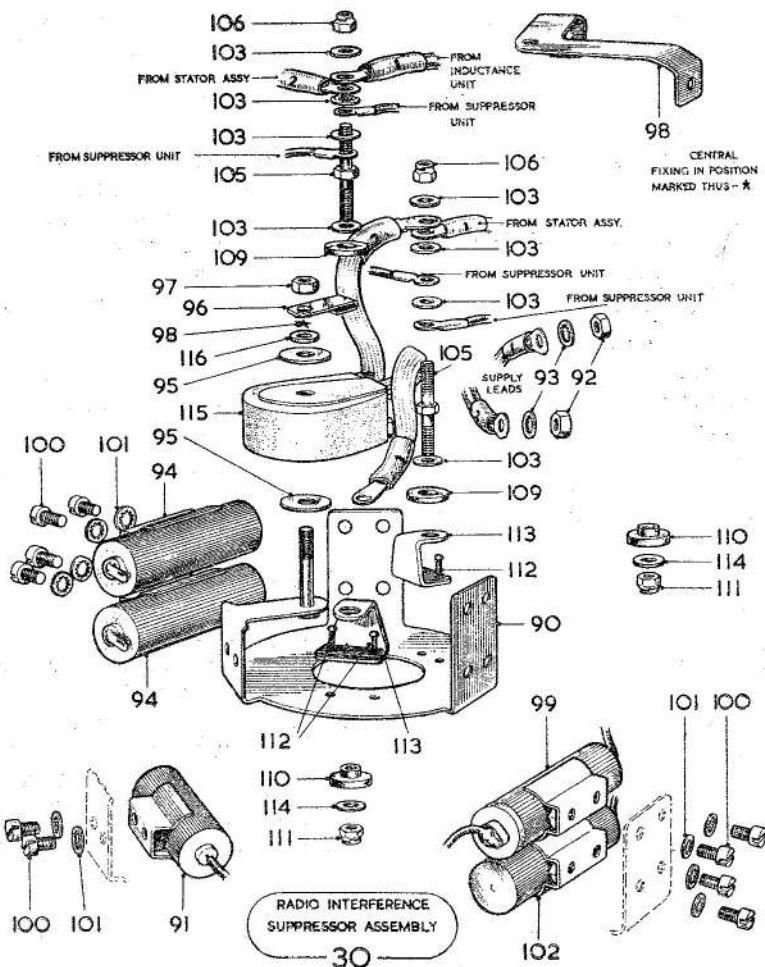

- |                               |                                 |
|-------------------------------|---------------------------------|
| 90 SUPPRESSION BRACKET        | 102 CAPACITOR (TYPE 335/64 A/1) |
| 91 CAPACITOR (TYPE 335/64A/1) | 103 PLAIN WASHER (4BA)          |
| 92 LOCKNUT (4BA)              | 105 TERMINAL POST               |
| 93 SHAKEPROOF WASHER          | 106 SELF-LOCKING NUT (4BA)      |
| 94 CAPACITOR (TYPE 335/668/1) | 109 TERMINAL INSULATING WASHER  |
| 95 MICA WASHER                | 110 TERMINAL INSULATING BUSH    |
| 96 TAG WASHER                 | 111 SELF-LOCKING NUT (4BA)      |
| 97 LOCKNUT (4BA THIN)         | 112 SNAP HEAD RIVET             |
| 98 ANTI-VIBRATION STRUT       | 113 TERMINAL BRACKET            |
| 99 CAPACITOR (TYPE 4774 A/2)  | 114 PLAIN WASHER                |
| 100 CH. HD. SCREW             | 115 INDUCTOR UNIT ASSEMBLY      |
| 101 SHAKEPROOF WASHER         | 116 PLAIN WASHER                |

Fig. 6. Exploded view of suppression unit assembly

~~RESTRICTED~~

polarity and clean the commutator with cleaning and de-oxidising solution.

(6) Wash the commutator with cold water.

(7) Apply rhodium at 4-6 volts for 18 amp./minutes.

(8) Wash the commutator in cold

water, wipe dry and remove the masking tape.

(9) Dry in a ventilated oven for 2 hours at 80°C.

(10) Using a 250V standard insulation resistance tester, check the insulation resistance of the armature, the reading obtained should not be less than 50 megohms.

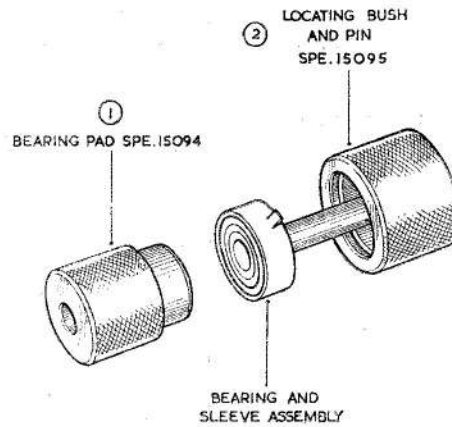

USE TOOLS IN A BENCH VICE

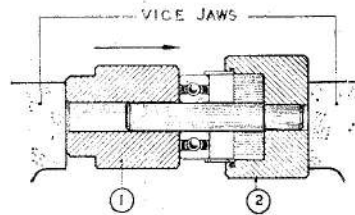

ASSEMBLY OF SLEEVED UPPER BEARING

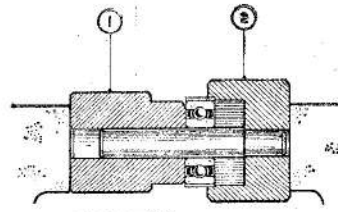

REMOVAL OF BEARING FROM SLEEVE

Fig. 7. Removal and replacement of the upper bearing sleeve

**RESTRICTED**

**TABLE 2**

**Detailed inspection of components**

Item	Inspection	Action if faulty
Armature	<p>Insulation resistance to shaft. Use a 500 volt insulation resistance tester.</p> <p>Commutator for loose conductors.</p> <p>Commutator for scoring.</p> <p>Fouling of armature on poles.</p> <p>Short or open circuited conductors. Use voltage drop tester or growler.</p> <p>Armature spindle for concentricity.</p>	<p>Clean thoroughly using white spirit. Dry for prolonged period at 105°C in a ventilated oven. Allow armature to cool. Check that insulation resistance is not less than 50 megohms. If below this figure continue drying process. Cool. Re-check.</p> <p>Reject for re-winding.</p> <p>Skim commutator. Minimum permissible diameter for further use is 30.0 mm. (1.181 in.). Undercut micas 0.5 mm. deep <math>\times</math> 0.036 in. wide as necessary. Check that no copper burrs are shorting across mica between segments. Commutator to be true with spindle to within 0.001 in. total indicator reading when running on journals. Rhodium plate the commutator as detailed in para. 24.</p> <p>Check spindle for concentricity and side play of bearings.</p> <p>Clean undercutting of mica between segments of commutator. Remove copper burrs. If still unsatisfactory, reject armature.</p> <p>Maximum eccentricity 0.025 mm. (0.001 in.); if excessive—reject.</p>
Field	<p>Charring or other evidence of overheating.</p> <p>Total resistance of windings 60.04 ohms <math>\pm</math> 5 per cent at 20°C.</p> <p>Continuity of coils. Use a 500-volt insulation resistance tester.</p> <p>Condition of field coils.</p> <p>Condition of field coil lead coverings.</p>	<p>Renew complete assembly.</p> <p>Renew complete assembly.</p> <p>Reject assembly.</p> <p>If damaged renew complete assembly.</p> <p>To replace damaged lead cut back the old lead, bare old and new lengths of lead for <math>\frac{5}{16}</math> in. minimum and clean the wires. Twist the bared wires together at least three times and solder. Bind the joint with silk tape and cover with 3 mm. in./dia. Systoflex sleeving. Varnish joint with air drying varnish.</p>

**~~RESTRICTED~~**

**TABLE 2—(contd.)**  
**Detailed inspection of components—contd.**

Item	Inspection	Action if faulty
Brush gear	<p>Brushes for wear.</p> <p>Fit of brush in boxes.</p> <p>Brush spring loading for 350° deflection from free position should be 350/400 gms. Alternatively for 375 gms. loading, deflection should be between 315°/345°.</p> <p>Examine brush pigtailed for fraying and looseness in brush carbon.</p>	<p>Renew brushes if worn below 10.6 mm.</p> <p>Brushes should slide freely in boxes. Remove all carbon that has collected in corners of brush boxes.</p> <p>Renew.</p> <p>Renew brush assembly.</p>
Bearings	<p>It is recommended that new ball bearings are fitted at each overhaul of the pump.</p>	
Metallic bellows gland	<p>Scoring of seal face.</p> <p>Damage to bellows gland convolutions.</p>	<p>If slight re-lap to a mirror finish. If excessive, renew bellows.</p> <p>Renew unit.</p> <p>Do not remove bellows gland from housing.</p>
Thrower assembly	<p>Scoring of carbon seal face and wear.</p>	<p>If slight re-lap to a mirror finish. If excessive, renew. (Table 3).</p>
Filter assembly	<p>Damaged wire mesh.</p>	<p>Renew.</p>
Gasket and joint rings	<p>Renew at each overhaul.</p>	<p>Renew.</p>
Electrical connection	<p>Chipped bakelite plates or damaged threads. Loose contact pins.</p>	<p>Renew.</p>

~~RESTRICTED~~

**TABLE 2—(contd.)**  
**Detailed inspection of components—contd.**

Item	Inspection	Action if faulty
Electrical lead sub-assembly	Examine for worn insulation sleeving.	Recover or renew according to damage.
By-pass valve	Seal between flap sleeve and seating for scoring.	If slight, re-lap. If excessive renew assembly.
Capacitors	<p>Insulation of capacitor between one terminal and earth to be not less than 50 megohms. Use a 250-V standard insulation resistance tester.</p> <p>Dirt and carbon deposit on terminals.</p> <p>Fracture of terminal tags at bends.</p>	<p>Renew.</p> <p>Refer to CLEANING.</p> <p>Renew suppressor.</p>
Ball races	It is recommended that new bearings are fitted at each overhaul of the pump.	—
Inductance unit assembly	Check continuity of coils. Insulation resistance check between terminals to give infinity reading. Use a 250V standard insulation resistance tester.	Reject.

**RESTRICTED**

TABLE 3

## Schedule of fits, clearances and repair tolerances

Part and description	Dimensions New	Permissible worn dimen- sion for re-use.	Clearance New	Permissible worn clear- ance for re-use.	Remarks
<b>MOTOR UNIT</b>					
BRUSH LENGTH (ON LONG EDGE)	19.05 mm. (0.750 in.)	16.0 mm. (0.630 in.)	—	—	—
COMMUTATOR DIAMETER	31.3 mm. 31.1 mm.  (1.232 in.) (1.224 in.)	30.0 mm. (1.181 in.)	—	—	Refer to para. 24
ARMATURE END FLOAT	—	—	0.15 mm. max. (0.006 in.)	0.225 mm. max. (0.009 in.)	—
ARMATURE SHAFT IN DRIVE- END BALL RACE	Dia. { 11.995 mm. 11.985 mm. (0.4722 in.) (0.4718 in.)	—	—	—	Selective assembly.
	Bore { 12.00 mm. 11.992 mm. (0.4724 in.) (0.4721 in.)				
ARMATURE SPINDLE IN COM- MUTATOR-END BALL RACE	Dia. { 8.995 mm. 8.985 mm. (0.3541 in.) (0.3537 in.)	—	—	—	Selective assembly.

**RESTRICTED**

TABLE 3—(contd.)

## Schedule of fits, clearances and repair tolerances—(contd.)

Part and description	Dimensions New	Permissible worn dimen- sion for re-use.	Clearance New	Permissible worn clear- ance for re-use.	Remarks
ARMATURE SPINDLE IN COM- MUTATOR-END BALL RACE— (contd.)	Bore { 9.00 mm. 8.992 mm. (0.3543 in.) 0.354 in.)				
COMMUTATOR-END BALL RACE IN HOUSING	Dia. { 27.59 mm. 27.58 mm. (1.0862 in.) (1.0858 in.)	—	0.03 mm. 0.01 mm.	0.04 mm. (0.0016 in.)	—
	Bore { 27.61 mm. 27.60 mm. (1.087 in.) (1.0866 in.)		(0.0012 in.) (0.0004 in.)		
THROWER ASSEMBLY (Dim. A, fig. 9(a))	17.55 mm. 17.45 mm. (0.691 in.) (0.687 in.)	17.25 mm. (0.679 in.)	—		Scored surface of car- bon to be removed by lapping. Face must be square with axis.
HEIGHT OF THROWER NUT CARBON ABOVE MOTOR CASING (Dim. B, fig. 9(a))	23.69 mm. 23.59 mm. (0.933 in.) (0.929 in.)	—	—	—	Adjust dimensions with- in limits by using shims between thrower nut and inner race of bearing.

RESTRICTED

**TABLE 3—(contd.)**  
**Schedule of fits, clearances and repair tolerances—(contd.)**

Parts and description	Dimensions New	Permissible worn dimen- sion for re-use.	Clearance New	Permissible worn clear- ance for re-use.	Remarks
<b>PUMP UNIT</b>					
SETTING OF HELIX BLADE ABOVE FACE OR UPPER BASE (Dim. C, fig. 9(b))	1.5 mm. 1.0 mm. (0.059 in.) (0.039 in.)	1.5 mm. 1.0 mm. (0.059 in.) (0.039 in.)	—	—	Position can be adjusted by means of shims fitted between helix and im- peller.
HEIGHT OF VAPOUR GUIDE CONE MOUTH ABOVE UPPER BASE FLANGE (Dim. D, fig. 9(b))	3.7 mm. (0.146 in.)	3.7 mm. (0.146 in.)	—	—	—
RADIAL CLEARANCE BETWEEN IMPELLER AND VOLUTE (Dim. E, fig. 9(b))	—	—	0.25 mm. min. (0.010 in.)	0.25 mm. min. (0.010 in.)	
IMPELLER ECCENTRICITY	—	—	0.125 mm. max. (0.005 in.)	0.125 mm. max. (0.005 in.)	
IMPELLER PROJECTION BE- YOND FACE OF VOLUTE PLATE (Dim. F, fig. 9(b))	5.8 mm. 5.45 mm. (0.228 in.) (0.214 in.)	—	—	—	Projection can be con- trolled by shimming between impeller and helix.

**RESTRICTED**

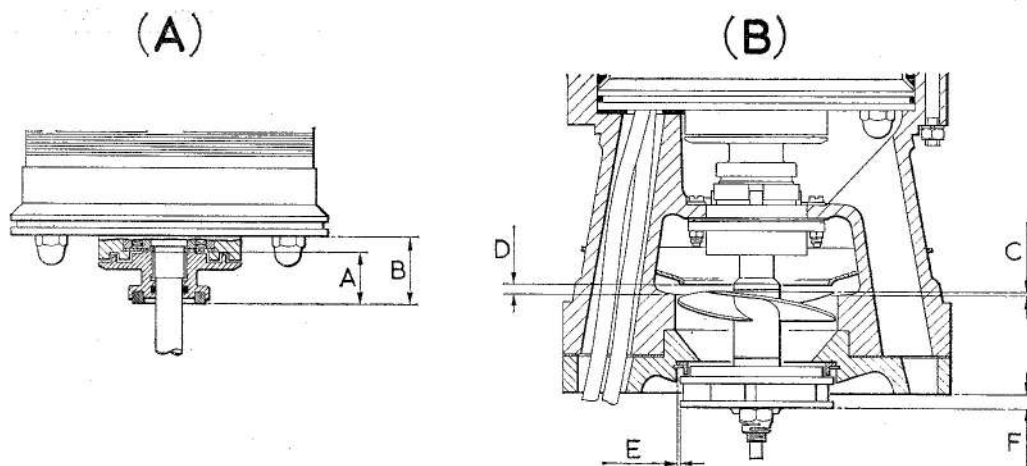

Fig. 8. Fits and clearance diagrams

### ASSEMBLING

(The numbers in brackets refer to the illustration quoted following the paragraph heading, unless otherwise indicated).

#### General

26. Maintain absolute cleanliness of the work bench and tools throughout the assembly of the pump. Retain the bearings in their wrappings until required for assembly. The special tools quoted in Table 1 or their equivalents should be used during the assembly of the pump whenever specified.

#### Motor unit

*Assembling the drive-end bearing (fig. 5)*

27. (1) Pre-select a bearing (18), that is a slide fit under thumb pressure both on the armature spindle and in the drive-end motor casing housing (15). Check that the bearing is smooth, running with no roughness of the tracks when the inner race is rotated by hand. Check that the bearing housing is perfectly clean and that the wall surface is free of score marks and burrs. Retain the armature assembly and the bearing and suitably mark both so that they can be paired together at a later assembly stage.

(2) Fit the drive-end bearing dust shield (17) and the selected bearing (18) into the housing in the drive-end casing (15).

(3) Fit the bearing retainer plate (16) over the bearing and secure with three round head screws (45) and spring washers (48).

*Assembling the commutator end bearing (fig. 5)*

28. (1) Pre-select an upper bearing (35) which is a slide fit under thumb pressure on the selected armature shaft (para. 27). Check that this bearing is smooth running with no roughness of the tracks when the inner race is rotated by hand.

(2) Assemble the selected bearing into the steel sleeve (37) using the special tools illustrated in Fig. 7.

(3) Fit the bearing and sleeve sub-assembly into the commutator-end motor casing (38). Ensure that the lugs on the sleeve (37) locate in the motor casing slots to prevent rotation of the assembly in the housing.

*Assembling the brush gear (fig. 5)*

29. (1) Place the lead distance washer (128) on one square-section support spindle of the brush-holder and carrier sub-assembly (122), with the flat edge of the washer towards the formed brush holder.

**Note . . .**

*If using the same carrier assembly previously fitted it should be aligned on re-assembly to the com-*

**RESTRICTED**

*mutator-end casing (38) with the marks made when dismantling. The distance washer (128) must therefore be assembled on the spindle which will be nearest to the recess in the motor casing rim through which the electric lead sub-assembly passes—the washer serves to displace these leads so that they do not foul the brush spring.*

- (2) Place a brush spring locating washer (129) on each spindle. Engage the central tongue of a brush spring (120) in the slot in each spindle.

**Note . . .**

*The working position of the brush spring requires between  $1\frac{1}{4}$  and  $1\frac{1}{2}$  turns of the spring from its free position, producing a working tension of 14/20 oz.*

- (3) Place a further spring locating washer (129) on each brush spring. Secure with split pins (121) by splaying the ends.

- (4) Refit the terminal screws (123) with a shakeproof washer (124) under the head of each from the inside of each bracket. Secure to each bracket with a locknut (125).

*Refitting the brush gear assembly to the commutator-end casing (fig. 5)*

30. (1) Replace the dust shield (22) in the recess in the back surface of the brush box assembly (39) and retain with a minimum quantity of Boscoprene Cement J.761.
- (2) Reposition the carrier assembly in the commutator-end casing (38), aligning (if the original assembly is being refitted) any marks made during dismantling.
- (3) Place the commutator-end bearing cover (24) in position on the motor casing and secure this and the brush carrier assembly to the casing with two screws (23) and spring washers (25).

*Assembling the armature to the drive-end casing (fig. 5)*

31. (1) Enter the armature shaft (19) through the bore of the paired bearing (18) (para. 27).

- (2) Fit an old thrower nut (11) or one with a damaged carbon and a number of shims (54) to act as spacers on the armature shaft and tighten against the inner race of the bearing using the special C-spanner.

**Note . . .**

*This is a temporary fitting to avoid possible damage to a new carbon during the assembly process.*

*Assembling the drive-end casing sub-assembly to the stator and commutator-end casing assemblies (fig. 5)*

32. (1) Position the motor casing and stator assembly (20) over the armature and locate the two fixed tie-bolts through the casing, at the same time threading the motor leads through the kidney shaped slot.

- (2) Secure with two dome nuts (53) and seal washers (52).

- (3) Carefully position the upper motor casing sub-assembly (para. 28) over the commutator-end of the armature, locating the armature shaft in the bore of the bearing and the fixed tie-rods of the stator assembly in the end casing. Take particular care not to scratch the rhodium-plated commutator on the brush boxes.

- (4) Securely clamp the assemblies together with tab-washers (42) and locknuts (41). Lock the washers by bending the narrow tabs against the motor casing and the broad tabs against a flat of the locknuts.

- (5) Place a plain washer (31) and a locknut (32) on the armature shaft and holding the thrower nut (11) with the special C spanner securely tighten the nut.

*Field lead positioning*

33. (1) Thread the two shunt connection leads (identifiable as the two of smallest diameter) through the small commutator-end casing rim slot together with one of the field coil leads.

- (2) Bring the second field coil lead out of the diametrically opposite end casing hole.

**RESTRICTED**

*Brush bedding (fig. 5)*

34. At this stage the pre-bedding of the brushes should be complete (para. 24), and should be followed by a motor run as follows:

- (1) Secure one field lead and one brush tag to each carrier terminal, securing both with spring washers (126) and locknuts (127).
- (2) Run the motor unit without load with the input supply set at 20V d.c. until the brushes are bedded over their full width of arc with at least 80 per cent of their face area contacting the commutator. The brush gear must be set in a position to giving minimum sparking at the commutator. Ensure that the brushes removed for examination are returned to their original brush boxes.

*Motor torque test (fig. 5)*

35. (1) Instal the motor unit in a tank recess surrounded by a suitable coolant maintained at a temperature of 20-25°C. It is suggested that an outer motor casing (44) should be set into the side wall of a small tank and the motor unit clamped in position.

(2) Connect the motor leads to a suitable d.c. power supply and with the input to the motor set at 26V d.c. run the motor on load for a short period of time, to allow the motor to warm up. Following this warming period, apply a load to the motor by means of a suitable dynamometer or calibrated fan SPE.14578 and check that the speed, torque loading and current consumption conform to the figures quoted as follows:

	Speed rev/min.	Torque oz./in.	Current con- sumption
Normal	5750 ± 100	72	18 (max)
High	6400 ± 100	91	25 (max)

(3) Adjust the brush assembly if necessary to bring the motor within the required limits of the torque test. With the motor removed from the tank recess and still running under load make a visual examination for the absence of sparking at the brushes.

(4) When the motor speed is correctly set, securely tighten the screws (23) and

apply a spot of air drying varnish to the end of each screw. Disconnect the electrical supply leads and remove the motor from the tank.

(5) Using a 250V standard insulation resistance tester, measure the insulation resistance of the motor, between the input leads and the casing, the reading obtained should not be less than 10 megohms.

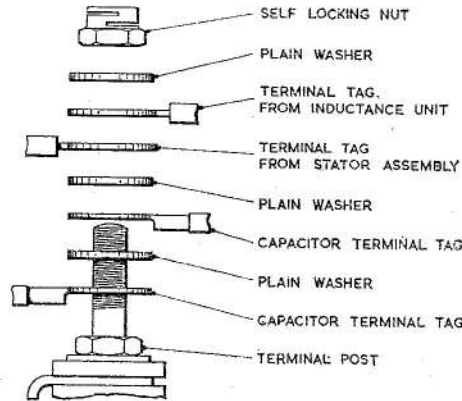

**Fig. 9. Exploded view of terminal assembly (suppression unit)**

*Assembling the suppression assembly (fig. 6)*

36. (1) If either of the terminal brackets (113) are damaged, refit new parts to the suppressor mounting bracket (90) using two snap-head rivets (112).

(2) Hold the insulation bush (110) in position under the top arm of the bracket (113), locating the spigot in the bracket. Place an insulation washer (109) and a plain washer (103) on top of the bracket arm.

(3) Insert a terminal stud (105) through the components and lock to the bracket (113) on the underside with a plain washer (114) and self-locking nut (111).

(4) Repeat sub-para. (2) and (3) of this paragraph for the second terminal post.

(5) Secure a capacitor (91) to the bracket in the position beneath the projecting arm carrying the inductance unit (115) fixing stud, with two cheese-head screws (100) and shakeproof washers (101).

**RESTRICTED**

**Note . . .**

*It is important that the contact area where each capacitor is fitted to the mounting bracket and also where the bracket is connected through spacers to the motor frame is thoroughly cleaned of protective finishes and the surfaces covered with a thin film of petroleum jelly to prevent corrosion. Clean and treat all capacitor mounting surfaces similarly.*

near side and the inductance unit stud uppermost, fit a lead through type capacitor (94) in the upper and lower positions of the left-hand support. Secure each with two cheese-head screws (100) and shakeproof washers (101).

(7) Fit a capacitor (99) in the upper position and a capacitor (102) in the lower position of the right-hand support. Secure each with two cheese-head screws (100) and shakeproof washers (101).

(6) With the capacitor (91) on the

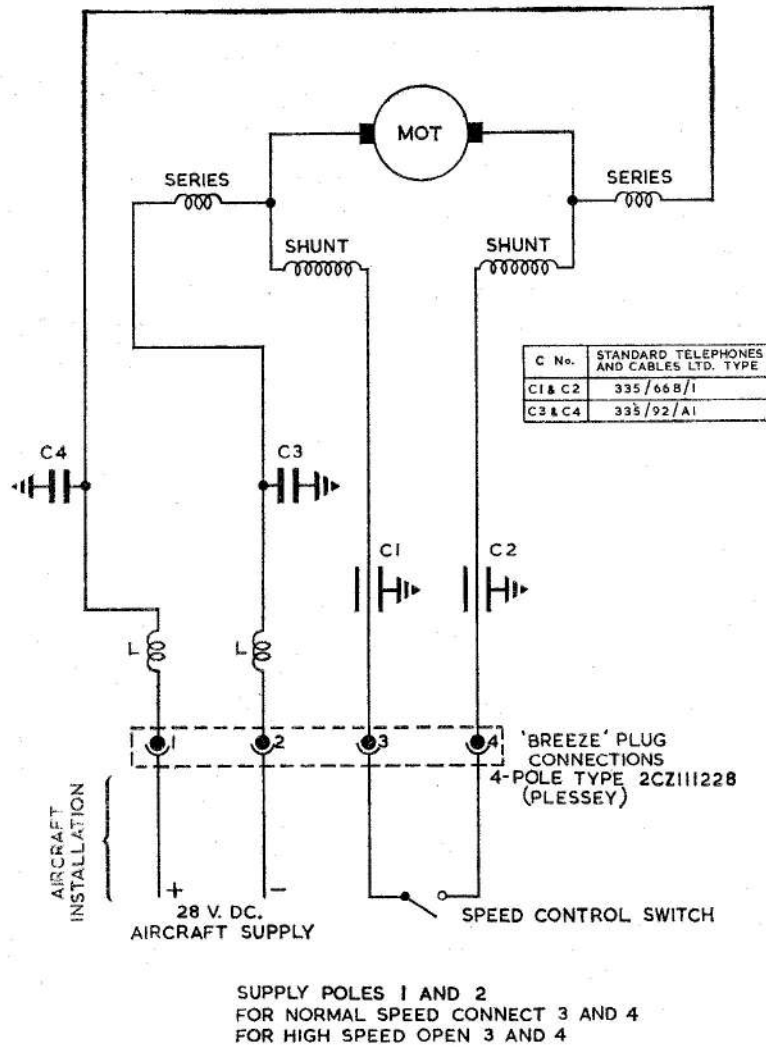

**Fig. 10. Circuit diagram: SPE.2009 series pumps**

**RESTRICTED**

(8) Place a mica washer (95) on the inductor unit stud in the suppressor bracket (90). Fit the inductance unit sub-assembly (115), a mica washer (95), a plain washer (116), the anti-vibration strut (98), a tab washer (96) and a lock-nut (97) in that order. Securely tighten the lock-nut after securing each arm of the anti-vibration strut (98) under a suppressor unit fixing screw.

(9) Connect the capacitor unit leads to the adjacent terminals, separating each tag with a plain washer (103). Take two suppressor leads and one inductor unit connection to each terminal assembly. Secure with a further plain washer (103) and self-locking nut (106). A diagrammatic arrangement of the terminal build-up is illustrated in Fig. 9 and the internal wiring of the pump assembly in Fig. 10.

(10) Using a 250V standard insulation resistance tester measure the insulation resistance between the centre-fixing stud and the inductor unit terminals, the reading obtained should be infinity.

*Fitting the suppression sub-assembly to the motor unit (fig. 5)*

37. (1) Secure the suppression network (30) to the commutator-end motor casing (34), spacing the unit from the motor casing with two spacers (36) and the earthing clamp block (26). Assemble the earthing clamp block adjacent to and along the edge of the cut-out in the commutator-end casing rim (38) to take the electrical lead assembly (21).

**Note . . .**

*Ensure that the contact surfaces between the suppressor network and motor end casing are clean and free of protective finishes.*

*Assembling the electrical-lead sub-assembly (fig. 5)*

38. (1) Thread the electric lead sub-assembly (21) through the stator and lower motor casing. Connect one of the two main supply leads (marked '1' and '2') to each inductor unit terminal. Secure with shakeproof washers (93, fig. 6) and lock-nuts (92).

(2) Using Fry's H.T.3 soft solder connect one of the two leads marked '3' and '4' to an end tag of each lead through suppressor (94) and a shunt

coil lead to the tag at the opposite end of the unit. Refer to the wiring diagram (fig. 10).

(3) Secure one series coil lead to each suppressor network terminal arrangement by removing the lock-nut (106, fig. 6) and plain washer (103, fig. 6) previously fitted. Tighten securely on replacement.

(4) Locate the lead assembly (21) in the rim slot of the motor end casing and clamp the lead assembly tightly across the metallic braided sleeves by securing the earthing clamp plate (27) to the earthing clamp block (26) with cheese-head screws (29) and shakeproof washers (28).

**Note . . .**

*Do not clamp the glass asbestos tape used to bind the two cable sheaths together.*

*Miscellaneous (fig. 1)*

39. Wire lock the dome nuts (53) using 22 SWG non corrodible steel locking wire.

**Pump unit**

*Replacing the thrower nut (fig. 5)*

40. (1) Remove the thrower nut (11) temporarily fitted (para. 31) using the special C spanner.

(2) Fit a new seal ring (10) in the internal groove of a new thrower nut assembly (11) and re-tighten the thrower nut.

(3) Using the tools illustrated in Fig. 11 check that the dimension from the face of the drive-end motor casing (15) to the face of the carbon gland in the thrower nut is as detailed in Table 3. This may be carried out as follows:—

(a) Using the tools illustrated set the clock gauge to zero reading.

(b) Using the knurled collar and clock assembly only, position it carefully on the carbon insert of the thrower nut allowing the gauge spindle to rest on the motor casing face. Read off on the dial the thickness of shim (54) required (if any), to correctly position the thrower nut.

**Note . . .**

*Take care not to damage the face of the carbon insert.*

**RESTRICTED**

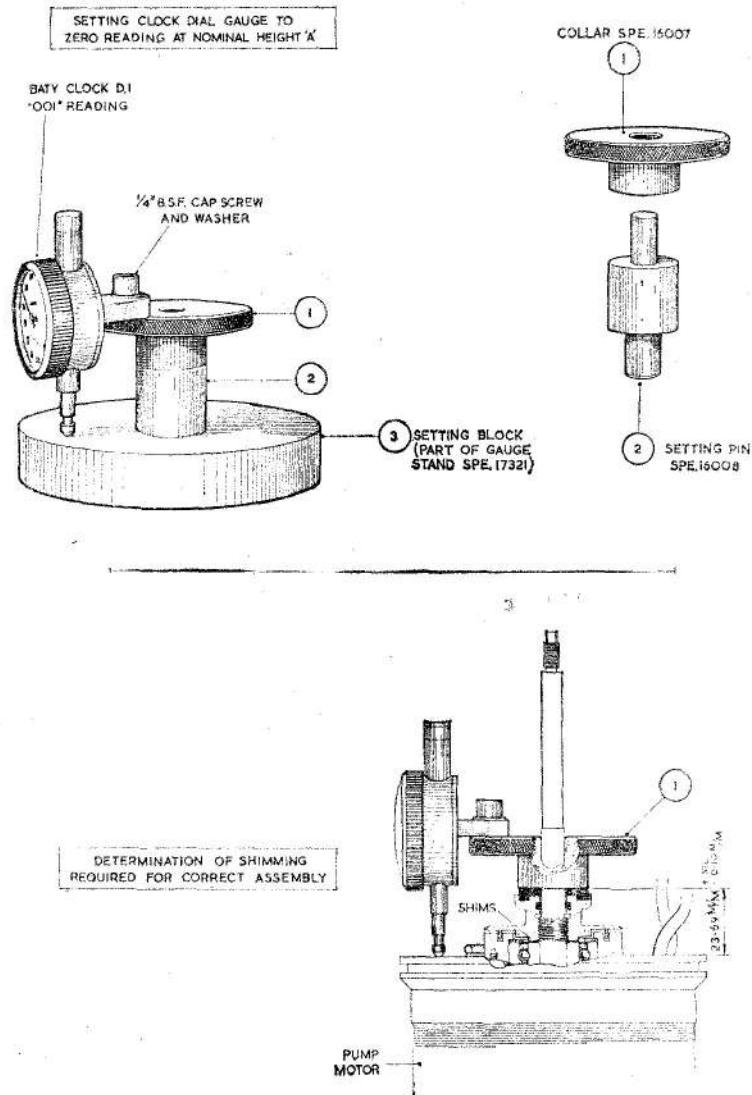

Fig. 11. Assembly of thrower nut/carbon gland seat

(c) Remove the thrower nut with the special C spanner. Select and fit shims (54) of the required total thickness.

(d) Smear the armature shaft (19) thread with Hermeticoll jointing compound, replace the thrower assembly and securely tighten.

(e) Recheck the height of the carbon seal face above the motor end casing as in sub-para. (3) (b) of this paragraph.

(4) Cradle the motor unit in vee-blocks and with a clock gauge check that the total eccentricity of the shaft measured at a point close to its end does not exceed 0.001 in.

*Fitting the upper base-assembly (fig. 4)*

41. (1) Renew any damaged studs (69,—1 off: 81,—2 off: 80,—4 off).

(2) Using the tools illustrated in Fig. 12 determine the correct thickness of shim (9) to be used between the bellows

**RESTRICTED**

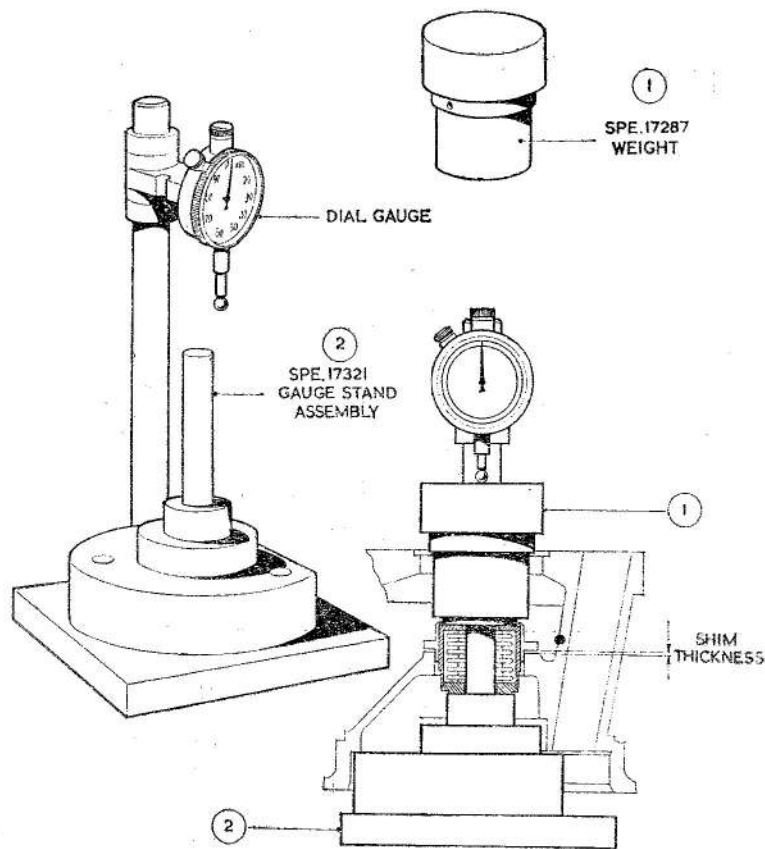

**Fig. 12. Tools for positioning the bellows gland sub-assembly**

housing sub-assembly (8) and the upper pump base (60) to position the bellows unit so that the loading on the final assembly is 18 ounces. Proceed as follows:—

(a) Position the bellows housing sub-assembly (8) in the upper pump base casting (60). The bellows housing must be easily moved by light pressure within the bore of the upper base casting and easily rotated to align the fixing holes.

(b) Place the upper base/bellows housing on the gauge stand assembly SPE.17321 with the bellows unit seal face contacting the tool surface.

**Caution . . .**

*Check that the tool surface is clean and free from burrs or*

*other foreign matter that might score the face of the bellows gland seal ring.*

(c) Place an 18-oz. weight SPE.17287 over the centre spigot of stand SPE.17321. Swing the clock gauge into position and set it to zero.

(d) Fully depress the weight with the fingers until the flange of the bellows housing contacts the upper base casting. The total indicated movement on the clock gauge is the thickness of shims (9) required to correctly position the bellows gland.

(e) Remove the weight assembly and pump base. Select shims (9) of correct total thickness  $+ 0.005$  in. compression allowance. Shims are available in thickness 0.006 in. and 0.030 in.

**RESTRICTED**

(f) Smear the shims with Wellseal jointing compound and position them between the bellows housing and the upper base. Secure the bellows housing assembly with the cheese-head screws (56), seal washers (57)—fitted under the screw heads, and self-locking nuts (58). The screws are inserted from the open end of the upper base.

(3) Space the vapour guide cone (59) from the upper base (60) with four long spacers (139) and one short (140). Secure in position with the hexagon head screws (135—2 off: 136—2 off and 137—1 off) and the self-locking nuts (141), fitting a plain washer (138) under the head of each screw. Before tightening locate the base on the vapour guide cone centralising gauge SPE.19546 (fig. 13). After tightening check that the height of the vapour guide cone mouth above the upper base flange is as detailed in Table 3.

*Assembling the motor unit to the upper pump base (fig. 5)*

42. (1) Fit a new rubber sealing ring (51) in the external groove of the drive-end casing (15). Lubricate this seal ring with a smear of Silicone grease MS.4, compound A.339 (Ref. No. 33C/9424829).

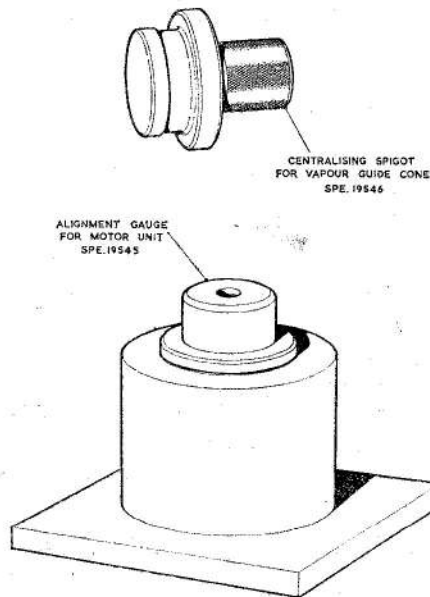

Fig. 13. Alignment and centralising gauges

(2) Position a new cable inlet seal washer (14, fig. 4) in the upper pump base.

(3) Locate the motor unit assembly on the dowel pin (133, fig. 4) in the upper base assembly, passing the motor leads down through the hollow pillar of the casting. Take care that the motor shaft does not foul and damage the bellows unit convolutions.

(4) Carefully position the pump base/motor unit assembly on the motor unit alignment gauge SPE.19545 (fig. 13), locating the motor shaft in the bore of the gauge.

(5) Wrap the corrugated stator cooling sleeve (43), round the motor unit and fit the outer casing (44). Place a new joint ring (50) in position, fit the clamping bolt ring (49) and insert the twelve bolts (46—11 off: 47—1 off) through the bolt ring and upper base casting. Assemble the clamping bolt ring with the larger diameter spigot compressing the joint ring.

(6) Fit twelve spring washers (13) and self-locking nuts (12) to secure motor unit to pump unit. Commencing with the nuts in line with the cable inlet seal washer (14, fig. 4) tighten diametrically opposite nuts in turn by degrees to ensure an even compression of the joint ring.

*Assembling the impeller helix (fig. 4)*

43. (1) Replace the distance piece (7) on the shaft.

(2) Select shims (6) to position the upper edge of the impeller helix (5) blades above the top face of the upper base casting flange as detailed in Table 3. Assemble the centrifugal impeller (63) and tighten the spindle end nut (73) to determine the position of the helix. When the correct shim thickness has been found, remove the end nut and the centrifugal impeller.

*Fitting the by-pass valve (fig. 4)*

44. (1) Check that the lapped surfaces of the by-pass valve plate (144) and the by-pass seating (132) are not damaged or scored.

**RESTRICTED**

(2) Smear the upper and side surfaces of the seating with 'Wellseal' jointing compound and position in the upper base recess.

(3) Prepare the volute plate (61) for fitting by smearing the upper face with 'Wellseal'. Also apply sealing compound to the lower face of the upper base.

(4) Place a new paper sealing washer (4) in position on the base studs after painting with 'Wellseal' jointing compound.

(5) Position the volute plate (61) over the studs. Before pressing into position insert the by-pass valve plate (144). Check that the valve plate hinges freely and secure the volute plate to the upper base casting (60) with three cheese-head screws (143) and spring washers (142).

*Assembling the centrifugal impeller (fig. 4)*

45. (1) Insert the floating impeller seal (62) in the volute plate and retain with the circlip (2).

(2) Complete the pump shaft assembly by pressing on the centrifugal impeller (63), locating the pin (3) in the hole in the stem of the impeller helix. Fit shims (70) between the centrifugal impeller

and the helix so that on tightening the shaft nut (73) the impeller projects beyond the lower face of the volute plate (61) as detailed in Table 3. Check that the radial clearance is as detailed in Table 3.

*Pressure testing the pump assembly*

46. (1) Bolt the blanking plate SPE.17412 (fig. 14) to the lower face of the volute plate fitting a gasket SPE.17413 (fig. 14) between the components. The motor supply leads should be housed in the closed tube of the blanking plate assembly.

(2) Connect the blanking plate union to an air supply. Gradually increase the applied air pressure from zero to 10 lb/in<sup>2</sup> and maintain the pressure for 1 minute. Air bubbles at the gland seal face will indicate leakage past the gland. If leakage is evident, the pump must be dismantled and the gland faces relapped. Re-assemble and repeat the test.

*Assembling the lower base (fig. 4)*

47. (1) Secure the fireproof cover assembly (76) to the lower base (65) with four round-head screws (75) and shakeproof washers (77).

(2) Replace the  $\frac{3}{4}$  in. B.S.P. pressure drain plug (146) and bonded seal washer (145).

(3) Smear the contact surfaces of the upper and lower base with 'Wellseal' jointing compound. Place a new paper seal washer (64) in position.

(4) Thread the electric lead sub-assembly (21) through the lower base boss and assemble the lower base on the studs of the upper base. Secure with seven lock-nuts (68) and spring washers (67).

*Assembling the electrical connection (fig. 4)*

48. (1) With reference to the wiring diagram in Fig. 10 connect the four motor leads, and the suppression leads to the appropriate pins on the Breeze plug.

(2) Secure the plug to the base casting with four screws (79) and shakeproof washers (78).

*Completing the pump assembly (fig. 4)*

49. (1) Wire lock the drilled upper base stud (69) with an approved locking seal.

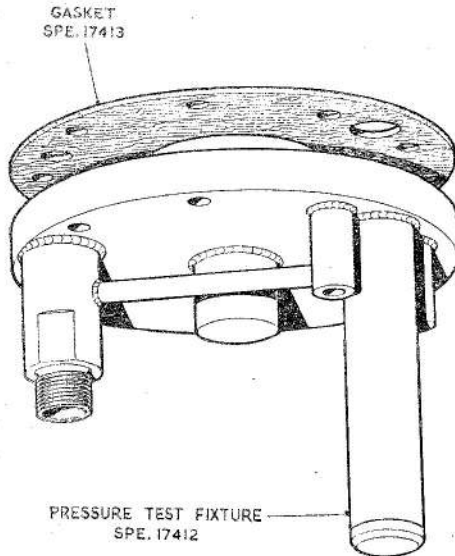

**Fig. 14. Tools for pressure testing the pump assembly**

**RESTRICTED**

(2) Place an aluminium jointing washer (74) on the central embossment of the lower base, refit the base cover (66) and secure in position with the  $\frac{3}{8}$  in. B.S.P. cover retaining plug (72) and a further washer (74).

(3) Place the filter assembly (55) in position around the upper base assembly and secure with two screws (134).

*Acceptance testing and wire locking (fig. 4)*

**50.** (1) The pump is now ready for acceptance testing and unless this is being carried out immediately, the whole unit should be enclosed in a polythene bag or other similar packing to prevent unnecessary ingress of dirt.

(2) After satisfactory completion of the acceptance tests, the two plugs (72) and (146) and the filter securing screws (134) should be wire-locked. The locking wire should be 22 S.W.G. non-corrodible steel and should pass round the outside of the fitting and locked in the direction in which the fitting is tightened. At least half-a-turn should be made and the end of the wire twisted at least three times.

(3) Use an approved seal to lock the drilled cover fixing bolt (47). Keep the sealing as close to the bolt as possible.

(4) If the pump is not to be used immediately, the delivery and gland drain outlets and the electrical connection should be plugged or tapped to prevent the ingress of dirt. Enclose the unit in a polythene bag and store in a moisture-free area away from excessive heat.

## TESTING

### General

**51.** The complete pump should be tested in accordance with the Schedule of Acceptance Tests detailed in para. 53-60. The pump should be rejected if it fails to meet the requirements of this test schedule.

### Test equipment

**52.** The universal fuel pump test rig is required to test these pump units, and should contain AVTUR fuel maintained at a temperature of 20-25°C.

## Schedule of Tests

### Gland leakage test

**53.** Fit the completed pump unit into the base of the fuel pump test rig and connect the appropriate fuel pipe hose to the pump delivery union. Connect the test rig electrical supply lead to the pump plug, and adjust the input to the pump motor to 29V d.c. With the pump primed and with a 12 in. head of fuel in the tank, superimpose air pressure at 10 lb/in<sup>2</sup> over the fuel. Close the fuel cock in the delivery line and run the pump ('no fuel flow') at normal speed for 15 minutes and for 5 minutes at high speed.

**54.** The maximum permissible leakage past the gland is 2 cc. per hour with the motor running and 1 cc. per hour with it stationary. Where leakage is in excess of this amount the pump should be dismantled and the carbon seal gland faces re-lapped. Re-assemble the pump and repeat the test. After satisfactory completion of this test, release the air pressure and open the fuel delivery cock.

### Note . . .

1 cc. = approx. 25 drops.

### Starting test

**55.** With the pump unit still connected to the test rig, adjust the input voltage to the pump motor to 18.5V d.c. Switch on the supply and with the motor switched to normal and then to high speed check that the motor starts immediately in both of the selected positions. Check the starting operation several times by interrupting the supply. Unsatisfactory starting of the pump motor should be investigated and the fault rectified.

### Endurance test

**56.** With a 12 in. head of fuel over the pump inlet, check the performance of the pump at each of the conditions detailed in Table 4. A period of time should be allowed for the pump to stabilise before checking its performance. Reject the pump if any appreciable change in performance is observed other than that caused by the initial warming period.

### Calibration test

**57.** Following the Endurance test, check that the pump performance conforms to the figures quoted in the Calibration Tables 5 and 6. The 'no delivery pressure' at the pump outlet should not exceed 28 lb/in.<sup>2</sup>

**RESTRICTED**

**TABLE 4**

**Endurance test**

Speed	Volts d.c.	Delivery pressure (lb./in. <sup>2</sup> )	Flow (g.p.h.)	Current—Amps (max.)
Normal	26	14	1000 (min.)	18
Normal	29	16.5	1000 (min.)	20
High	26	12.5	2000 (min.)	25
High	29	15.5	2000 (min.)	28

**TABLE 5**

**Calibration test (normal speed)**  
 Test at flows of 0, 400, 800, 1000, 1200, 1600 and 2000 g.p.h.

Volts d.c.	Flow (g.p.h.)	Delivery pressure (lb./in. <sup>2</sup> )	Current (amps)
29	1000	16.5 (min.)	20 (max.)
26	1000	14.0 (min.)	18 (max.)
25	1000	13.0 (min.)	17 (max.)

**TABLE 6**

**Calibration test (high speed)**  
 Test at flows of 0, 400, 800, 1200, 1600, 2000 and 2400 g.p.h.

Volts d.c.	Flow (g.p.h.)	Delivery pressure (lb./in. <sup>2</sup> )	Current (amps)
29	2000	15.5 (min.)	28 (max.)
26	2000	12.5 (min.)	25 (max.)
25	2000	12.0 (min.)	24 (max.)

when the pump is running at high speed with the input supply to the motor set at 29V d.c.

*Dry test*

**58.** Remove the pump unit from the test rig and run the pump 'dry' for a period of 2.5 minutes with the pump motor switch selected at its normal, and high speed positions. The current consumption should not exceed 8 A at normal speed, or 11 A at high speed.

**Note . . .**

*The 'dry' running test should be carried out immediately following the Calibration test to ensure that the seal faces are lubricated. Running the seal dry may*

*result in damage to the pump. Precautions should be taken to ensure that the pump is immersed in fuel before this test if there has been more than a few hours elapsed time since the previous test.*

*Bonding*

**59.** The electrical resistance measured between any two points of bond must not exceed 0.05 ohms.

*Insulation resistance test*

**60.** Using a standard insulation resistance tester measure the insulation resistance between the pins of the pump electrical plug and the casing, the reading obtained must not exceed 2 megohms.

**~~RESTRICTED~~**

TABLE 7

## Faults, possible causes and remedies

## (A) Motor unit only

Fault	Possible causes	Remedy
Sparking at commutator	(a) Brush sticking in brush box	Clean brush faces and inner surface of brush box. If necessary, rub sides of brush with grade 000 glasspaper. Remove minimum amount of carbon to ensure that brush slides easily in box.
	(b) Brush incorrectly bedded	Re-bed brush as detailed in assembly instructions.
	(c) Broken brush	If edge is chipped, re-bed or if excessive, fit new brush. Check commutator for high segments which might cause chipping.
	(d) Low brush spring pressure	Check that springs are locating correctly on the brushes and not off-set on to brush box. Check spring characteristics as detailed in Table 2.
	(e) Dirty commutator	Clean brushes and commutator with a petrol moistened cloth.
	(f) Brushes too short	Refer to Table 3 for minimum re-usable length. Rapid wear indicates commutation faults.
	(g) Loose or damaged brush box	Tighten all securing screws. Renew a damaged box.
	(h) Unequal current distribution between brushes	Check brush connections for tightness.
	(i) Commutator tracked, out of true or with mica insulation between segments standing proud of commutator surfaces.	Remove armature and diamond turn commutator. Check concentricity with shaft journals. Refer to Table 2.
	(j) Defective armature winding	Test armature by voltage drop method. Fit a new armature if fault is discovered.
	(k) High armature current	May be caused by loose connections, short circuit in armature or an overload.
Chattering brushes	High, low or loose commutator segments, proud micas, ridges or flats, on commutator	Dismantle and diamond turn commutator. Refer to Tables 2 and 3.

~~RESTRICTED~~

TABLE 7—(contd.)

Faults, possible causes and remedies—(contd.)

Fault	Possible causes	Remedy
Overheating	(a) Overload	Reduce load.
	(b) Low insulation resistance	Clean thoroughly. Dry windings (Table 2).
	(c) Faulty field assembly	Examine connections, sleeving etc. for damage.
Over-speeding	Weak field	Examine all connections. Check field assembly (Table 2). Renew if necessary.
Low torque	(a) Dirty commutator	Clean commutator and brushes with petrol moistened cloth. Check connections for tightness and cleanliness. Check field coils for continuity.
	(b) Excessive friction	Test armature for fouling. Check bearings. If fault persists, ascertain cause.
Motor runs too slowly	(a) Excessive friction	Refer to Low torque (c).
	(b) Faulty armature	Check by voltage drop method.
	(c) Overload	Reduce overload.
Motor fails to start	(a) Overload	Reduce load.
	(b) No supply	Check voltage at motor terminals.
	(c) Excessive friction	Refer to Low torque (c).
	(d) Short circuit in field assembly	If windings are damp, dry as detailed in Table 2. If windings are faulty, renew field assembly.
	(e) Open circuit	Remove armature and check by voltage drop method. Check field circuit for continuity.
	(f) Brushes not contacting commutator	Various: Refer to Sparking at commutator (a), (c), (d), (f) and (g).

~~RESTRICTED~~

TABLE 7—(contd.)

## Faults, possible causes and remedies—(contd.)

Fault	Possible causes	Remedy
(B) Complete pump assembly		
Gland leakage	(a) Bad finish between gland seal faces (b) Insufficient pressure between gland seal faces	Dismantle pump and re-lap gland seal faces. Check gland loading. If light reduce thickness of shims fitted between bellows housing and the upper pump base casting.
Excessive current consumption	(a) Excessive loading on bellows gland (b) Faulty motor unit (c) Fouling of impeller by foreign matter	Dismantle and check gland loading. If excessive, fit thicker shim. Refer to section (A) of this table. Dismantle pump base and examine for obstruction. Check that impeller is not fouling bore of volute plate. If components are undamaged, clean and re-assemble.
Low delivery pressure	Faulty motor	Refer to section (A) of this table.
Pressure surge	(a) Excessive loading on bellows gland (b) Tight or pre-loaded bearings.	See notes on excessive current. Dismantle. Check fits and ease or replace as necessary. Refer to Section (A) of this table.
Low or fluctuating amps.	(a) Impeller impedance (b) Faulty motor unit	Check for obstruction. Check for clearances. Refer to section (A) of this table.
Very high current consumption	Short circuit	Refer to section (A) of this table.

**RESTRICTED**

(

(

(

(

## Appendix 1

RECONDITIONING THE MOUNTING PLATE ASSEMBLY  
FOR SPE.2009 AND SPE.2009A SERIES PUMPS**General**

1. The mounting plate for the SPE.2009 and SPE.2009A series pumps is designed for bolting to a stud ring in the base of the aircraft fuel tank through 34 flange holes and carries a bolt ring for attachment of the fuel pump. A synthetic rubber joint ring cemented in a groove in the mounting flange effects the seal between the mounting plate and the fuel tank.

2. Dismantling the mounting plate assembly should be confined to the following points:—

(1) Removal of the joint ring (150, app. 1, fig. 1) for renewal after a two year installation period or if damaged.

(2) Removal of any damaged or corroded studs (152) the drain plug (156) and washer (157).

**Assembling**

3. (1) Replace any studs (152) removed from the mounting plate (151).

(2) Fit a new joint ring (150) in the flange groove in accordance with the following procedure:—

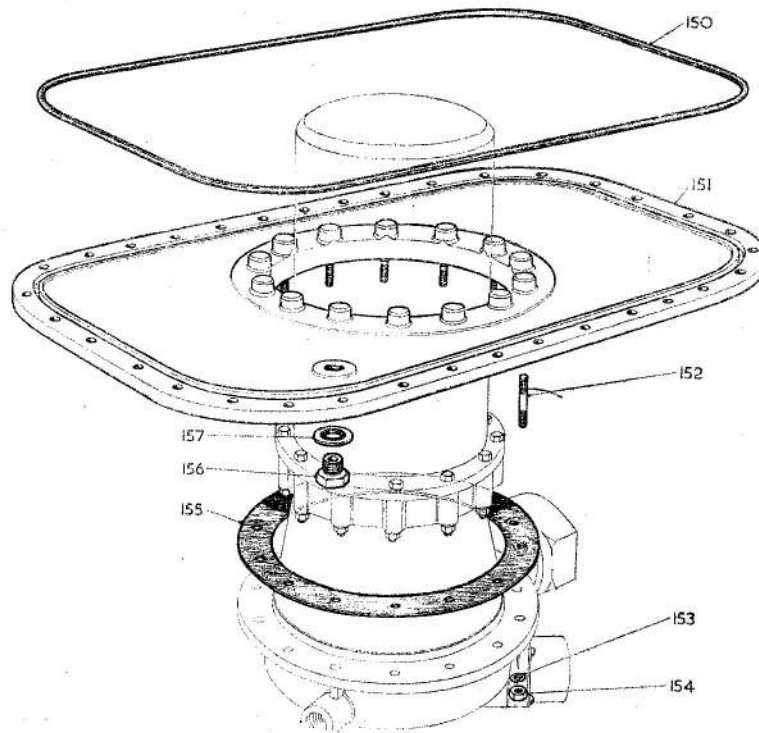

150 MOUNTING PLATE SEAL RING  
151 MOUNTING PLATE  
152 STUD  
153 2BA SPRING WASHER

154 2BA NUT  
155 PUMP/MOUNTING PLATE JOINT WASHER  
156 1/8 IN. B.S.P. PLUG  
157 BONDED SEAL WASHER

Fig. 1. Exploded view of mounting plate assembly

~~RESTRICTED~~

(a) Ensure that all traces of dried rubber cement have been removed from the groove.

(b) Remove flash from all corners of the new joint ring (150).

(c) Clean the contacting surface of the mounting plate with Boscoprene No. 6104 cleaner.

(d) Prime with Boscolite Primer 147A and allow to dry for at least 1 hour.

(e) Coat the groove with Boscoprene

Cement J.761, parts A and B. Allow to dry for at least  $\frac{1}{2}$  hour.

(f) Add a second coat of cement as in (e) above. Allow to dry  $\frac{1}{4}$  hour.

(g) Assemble the ring into the groove. Do not stretch the ring when assembling—the rubber must be pressed back as it is fed into the groove.

(h) Allow the assembly to cure for 24 hours.

(3) Fit the drain plug (156) with a new seal washer (157).

~~RESTRICTED~~

## Appendix 2

## RECONDITIONING SPE.2009 MK. 4 FUEL PUMPS

## LIST OF CONTENTS

	Para.		Para.
<i>General</i> ... ..	1	<b>Assembling</b>	
<b>Reconditioning</b>		<i>Detailed procedure</i> ... ..	4
<i>Tools and test equipment</i> ... ..	2	<b>Testing</b>	
<b>Dismantling</b>		<i>General</i> ... ..	5
<i>Detailed procedure</i> ... ..	3		

**General**

1. This appendix details the differences in the dismantling and re-assembly procedure for SPE.2009 Mk. 4 fuel pumps as compared with those given for SPE.2009 Mk. 5 in the basic chapter. Full details of differences between SPE.2009 pumps are given in A.P.4343D, Vol. 1, Book 2, Sect. 7. Although details are given for the repair of the Mk. 4 pump to its original standard, it is recommended that whenever possible, the pump is rebuilt to the latest modification standards.

**RECONDITIONING****Tools and test equipment**

2. All the tools listed in Table 1 of the basic chapter are required when servicing the SPE.2009 Mk. 4 pumps.

- (1) General—locking wire and electrical connection removal.
- (2) Separating and dismantling the lower base assembly.
- (3) Removing the impeller and impeller helix.
- (4) Separating the motor unit from the upper base.
- (5) Dismantling the upper base assembly.
- (6) Dismantling the motor unit—removing the suppression assembly.

(7) Dismantling the suppression network.

(8) Removing the brushes.

(9) Removing the armature and drive-end motor casing. Earlier design of the armature (19, fig. 5) fitted.

(10) Separating the armature from the drive-end motor casing. Generally as for the SPE.2009 Mk. 5 in the basic chapter but an earlier design of the bearing retainer plate (16) is fitted.

(11) Separating the commutator-end motor casing from the stator assembly.

(12) Dismantling the commutator-end casing. Generally as for the SPE.2009 Mk. 5 in the basic chapter but an earlier design of the upper bearing dust shield (22) is fitted.

**DISMANTLING****Detailed procedure**

3. Where no details are given under the stage headings in the following breakdown, reference should be made to the equivalent paragraph in the dismantling instructions in the basic chapter.

**ASSEMBLING****Detailed procedure**

4. Where no details are given under the stage headings in the following rebuild sequence, refer to the equivalent paragraph in the assembly instructions in the basic chapter.

**RESTRICTED**

(1) Motor unit—assembling the drive-end bearing. Generally as for the SPE.2009 Mk. 5 in the basic chapter, but an earlier design of the bearing retainer plate (16) is fitted. The armature used is also of earlier design and does not incorporate features introduced on Mk. 5 pumps to improve the mounting of the bearings.

(2) Assembling the commutator-end bearing. Basically as for the SPE.2009 Mk. 4 pump but an earlier design of the upper bearing dust shield (22) is fitted, suitable for use with the earlier design of the armature.

(3) Assembling the brush gear.

(4) Refitting the brush gear assembly to the commutator-end casing.

(5) Assembling the armature to the drive-end motor casing. An earlier design of the armature (19) is used on Mk. 4 pumps (refer to sub-para. (1) of this paragraph).

(6) Assembling the drive-end casing sub-assembly to the stator and commutator-end casing assemblies.

(7) Field lead positioning.

(8) Pre-bedding the brushes.

(9) Brush bedding: motor torque test.

(10) Assembling the suppression assembly.

(11) Fitting the suppression sub-assembly to the motor unit.

(12) Assembling the electrical-lead sub-assembly.

(13) Replacing the thrower nut.

(14) Fitting the upper base sub-assembly.

(15) Assembling the motor unit to the upper base.

(16) Assembling the impeller helix.

(17) Fitting the by-pass valve.

(18) Assembling the centrifugal impeller.

(19) Pressure testing the pump assembly.

(20) Assembling the lower base.

(21) Completing the pump assembly.

(22) Acceptance testing and wire-locking.

## TESTING

### General

5. The complete pump assembly must be tested in accordance with the Schedule of Tests detailed in para. 53-60 of the basic chapter.

~~RESTRICTED~~

## Appendix 3

## RECONDITIONING SPE.2009A MK. 4 &amp; 5 FUEL PUMPS

## LIST OF CONTENTS

	Para.		Para.
<i>General</i> ... ..	1	<b>Assembling</b>	
<b>Reconditioning</b>		<i>Detailed procedure</i> ... ..	4
<i>Tools and test equipment</i> ... ..	2	<b>Testing</b>	
<b>Dismantling</b>		<i>General</i> ... ..	5
<i>Detailed procedure</i> ... ..	3		

## LIST OF ILLUSTRATIONS

	Fig.
<i>Exploded view of suppression unit sub-assembly</i> ... ..	1
<i>Diagrammatic arrangement of suppression unit</i> ... ..	2
<i>Circuit diagram — SPE.2009A series fuel pumps</i> ... ..	3

**General**

1. This appendix details the differences in the dismantling and re-assembling procedure for SPE.2009A Mk. 4 and Mk. 5 fuel pumps by comparison with the information given for SPE.2009 Mk. 5 fuel pumps in the basic chapter. The SPE.2009A pump differs from the SPE.2009 only in the design of the radio interference suppression network fitted to the motor unit. Mk. 5 pumps incorporate improved mounting of the motor unit upper and lower bearings, and Mk. 4 pumps should always be re-built to this standard whenever possible.

**RECONDITIONING****Tools and test equipment**

2. All the tools listed in Table 1 of the basic chapter are required when overhauling SPE.2009A Mk. 4 and 5 pumps.

**DISMANTLING****Detailed procedure**

3. Where no details are given under the

stage headings in the following breakdown, refer to the equivalent paragraph in the dismantling instructions in the basic chapter.

- (1) General—locking wire and electrical connection.
- (2) Separating and dismantling the lower base assembly.
- (3) Removing the impeller and impeller helix.
- (4) Separating the motor unit from the upper base.
- (5) Dismantling the upper base.
- (6) Dismantling the motor unit—removing the suppression assembly. Basically as detailed in the main chapter for SPE.2009 Mk. 5 pumps but suppression assembly is of revised design.
- (7) Dismantling the suppression assembly (refer to app. 3, fig. 1).

~~RESTRICTED~~

178 RADIO INTERFERENCE SUPPRESSOR ASSEMBLY

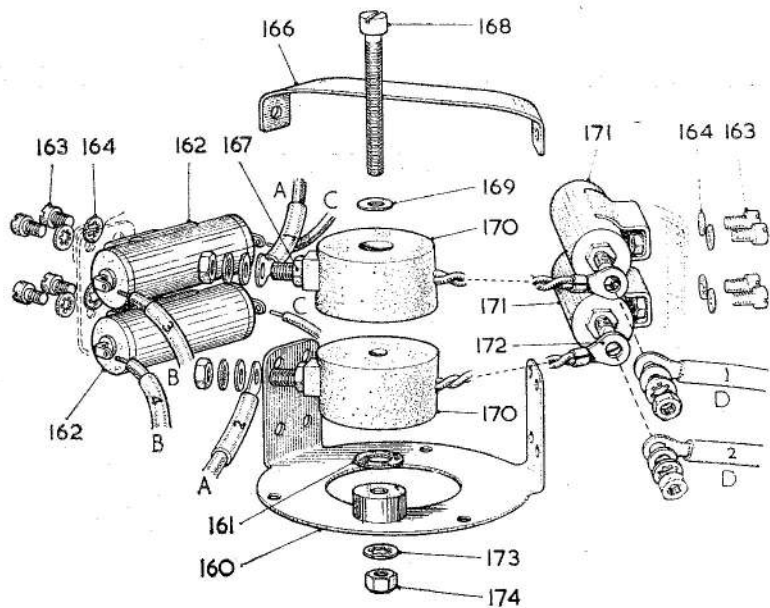

LEADS A - SUPPLY LEADS  
 LEADS B - SUPPLY LEADS  
 LEADS C - FROM STATOR ASSY. (SHUNT WINDING)  
 LEADS D - FROM STATOR ASSY. (SERIES WINDING)

ALL TERMINALS SECURED WITH:  
 PLAIN WASHER 175  
 SHAKEPROOF WASHER 176  
 THIN NUT 177

- |   |  |
|---|--|
| 160 CAPACITOR MOUNTING BRACKET SUB-ASSEMBLY | 170 COIL MOULDING ASSEMBLY               |
| 161 INSULATION (MICAGLASS) WASHER           | 171 CAPACITOR (SPE. 12055)               |
| 162 CAPACITOR (TYPE 355/66B/1)              | 172 TAG (2BA)-(COIL MOULDING LEADS)      |
| 163 CH. HD. SCREW (4BA)                     | 173 SHAKEPROOF WASHER (2BA)              |
| 164 SHAKEPROOF WASHER (4BA)                 | 174 THIN NUT (2BA)                       |
| 166 ANTI-VIBRATION STRUT                    | 175 PLAIN WASHER (2BA)                   |
| 167 THIN NUT (2BA)                          | 176 SHAKEPROOF WASHER                    |
| 168 CH. HD. SCREW (2BA)                     | 177 THIN NUT (2BA)                       |
| 169 PLAIN WASHER (2BA)                      | 178 SUPPRESSION ASSEMBLY (ITEMS 160-177) |

Fig. 1. Exploded view of suppression unit

(a) Individual capacitors (162—2 off (app. 3, fig. 1); 171—2 off) can be removed by unscrewing and removing the two cheese-head screws (163) and shakeproof washers (164) securing each unit to the bracket (160).

(b) Remove the coil assemblies (170) from the bracket (160) by removing the locknut (174) and shakeproof washers (173). The centre

screw (168) can be unscrewed from the coil support bush to release the coil assemblies, plain washer (160) and micaglass insulating washer (161).

(8) Removing the brushes.

(9) Removing the armature and drive-end motor casing. An earlier design of the armature is fitted to Mk. 4 units.

~~RESTRICTED~~

(10) Separating the armature from the drive-end motor casing. An earlier design of the bearing retainer plate (16, fig. 5) is fitted to Mk. 4 units.

(11) Separating the commutator-end motor casing from the stator assembly.

(12) Dismantling the commutator-end casing. An earlier design of the upper bearing dust shield (22) is fitted to Mk. 4 units.

## ASSEMBLING

### Detailed procedure

4. Where no details are given under the stage headings in the following re-build

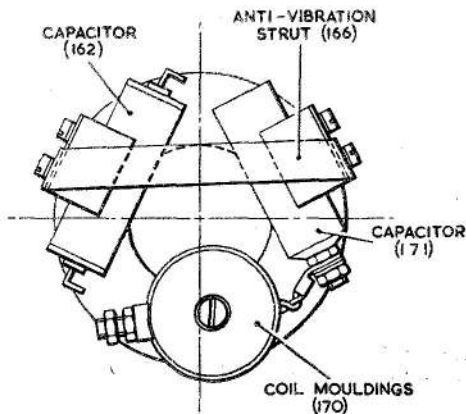

Fig. 2. Diagrammatic arrangement of suppression unit

sequence, refer to the equivalent paragraph in the assembly instructions in the basic chapter.

(1) Motor unit—assembling the drive-end bearing. On Mk. 4 units only an earlier design of the bearing retainer plate (16, fig. 5) and armature (19) are fitted. The latter does not incorporate features introduced into the Mk. 5 pump to improve the mounting of the bearings.

(2) Assembling the commutator-end bearing. On Mk. 4 units only an earlier design of the upper bearing dust shield (22) is fitted.

(3) Assembling the brush gear.

(4) Refitting the brush gear assembly to the commutator-end casing.

(5) Assembling the armature to the drive-end motor casing. An earlier design of the armature is fitted to Mk. 4 units and does not incorporate features to improve the mounting of the bearings.

(6) Assembling the drive-end casing sub-assembly to the stator and commutator-end assemblies.

(7) Field lead positioning.

(8) Pre-bedding the brushes.

(9) Brush bedding—motor torque test.

(10) Assembling the suppression assembly.

(a) Place an insulating washer (161, App. 3, fig. 1) on the coil support bush rivetted to the bracket (160).

(b) Position two coil moulding assemblies (170) on the washer with the terminal studs to the left hand side as indicated in App. 3, Fig. 2. Retain with the cheese-head screw (168) and plain washer (169). Lock the screw to the underside of the bracket with a shakeproof washer (173) and locknut (174).

(c) Secure two capacitors (162) to the left-hand arm of the bracket (App. 3, fig. 2) with cheese-head screws (163) and shakeproof washers (164).

(d) Secure two capacitors (171) to the right-hand arm of the bracket with cheese-head screws (163) and shakeproof washers (164).

(e) Connect the anti-vibration bracket (166) under one of the upper pair of capacitor unit fixing screws on each arm of the bracket.

(11) Fitting the suppression sub-assembly to the motor unit. Generally

**RESTRICTED**

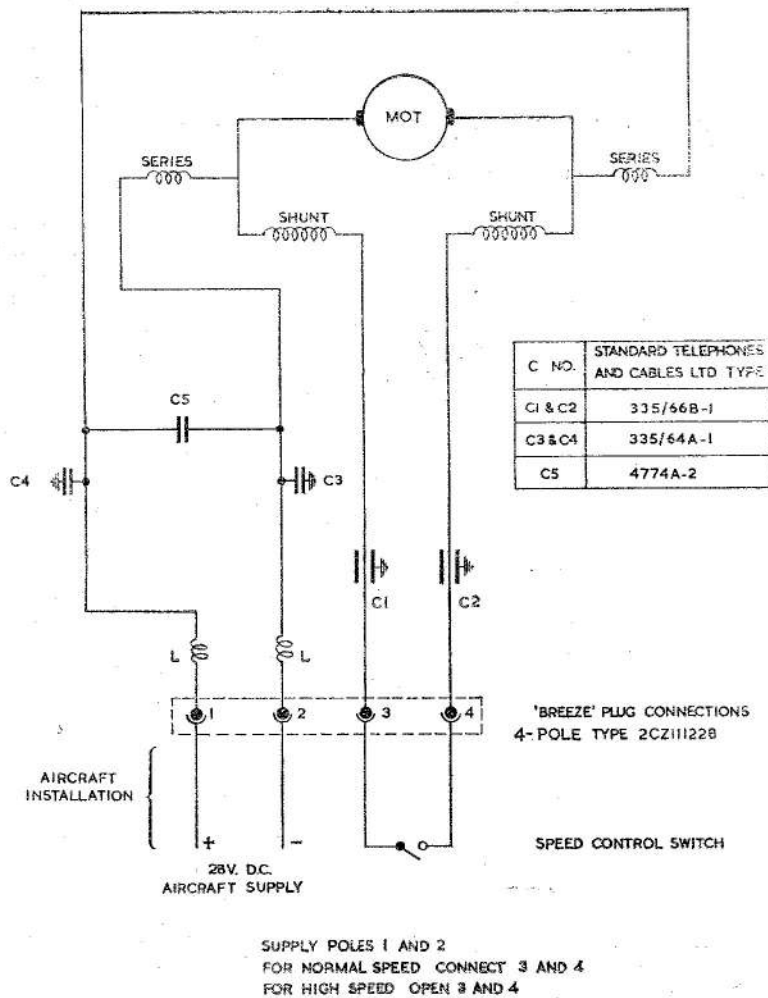

**Fig. 3. Circuit diagram: SPE.2009A series fuel pumps**

as described in the basic chapter but fit the suppression unit sub-assembly (178).

(12) Assembling the electric lead sub-assembly.

(a) Refer to the wiring diagram App. 3, Fig. 3. Thread the electric lead sub-assembly (21, fig. 2) through the stator and drive-end motor casing. Connect one of the two main supply leads (marked '1' and '2') to each coil assembly (170, App. 3, Fig. 1) terminal. Secure with a plain washer (175), shakeproof washer (176) and nut (177).

(b) Using Frys H.T.3 solder, connect one of two leads marked '3' and

'4' to an end tag of each capacitor (162). Connect a shunt lead to the tag at the opposite end of each unit.

(c) Secure one series winding connection and one coil tag (172) to the terminal of each capacitor unit (171). Secure with a plain washer (175), shakeproof washer (176) and thin nut (177).

(d) Locate the lead assembly in the rim slot of the motor end casing and clamp the lead assembly tightly across the metallic braid sleeves by securing the earthing clamp (27, fig. 5) to the clamp block (26) with cheese-head screws (29) and shakeproof washers (28).

**RESTRICTED**

**Note . . .**

*Do not clamp across the glass asbestos tape used to bind the two cable sheaths together.*

- (13) Replacing the thrower nut.
- (14) Fitting the upper base sub-assembly.
- (15) Assembling the motor unit to the upper base.
- (16) Assembling the impeller helix.
- (17) Fitting the by-pass valve.
- (18) Assembling the centrifugal impeller.

(19) Pressure testing the pump assembly.

(20) Assembling the lower base.

(21) Completing the pump assembly.

(22) Acceptance testing and wire locking.

**TESTING****General**

5. The complete pump assembly should be tested in accordance with the Schedule of Tests detailed in para. 53-60 of the basic chapter.

**RESTRICTED**

Faint, illegible text in the upper left quadrant of the page.

Faint, illegible text in the upper right quadrant of the page.

This file was downloaded  
from the RTFM Library.

Link: [www.scottbouch.com/rtfm](http://www.scottbouch.com/rtfm)

Please see site for usage terms,  
and more aircraft documents.

