

Do not destroy

## Chapter 46

## PUMP, FUEL, TYPE SPE.203 Mk. 2

## LIST OF CONTENTS

	Para.		Para.
<i>Introduction</i> ... ..	1	<i>General</i> ... ..	18
<b>Reconditioning</b>		<i>Brush holder assembly</i> ... ..	19
<i>Tools and test equipment</i> ... ..	3	<i>Assembling the brush gear</i> ... ..	20
<b>Dismantling</b>		<i>Assembling the upper bearing</i> ... ..	21
<i>General</i> ... ..	4	<i>Pre-bedding the brushes</i> ... ..	22
<i>Removing the top cover</i> ... ..	5	<i>Assembling the lower bearing</i> ... ..	23
<i>Withdrawing the impeller and seal assemblies</i> ... ..	6	<i>Motor speed setting</i> ... ..	24
<i>Withdrawing the motor unit</i> ... ..	7	<i>Brush bedding motor run</i> ... ..	25
<i>Dismantling the motor</i> ... ..	8	<i>Transferring the motor unit components to the pump body</i> ... ..	26
<b>Cleaning, examination and repair</b>		<i>Adjusting the shaft end loading</i> ... ..	27
<i>Cleaning</i> ... ..	9	<i>Assembling the seal and impeller</i> ... ..	28
<i>Examination</i>		<i>Completing the pump assembly</i> ... ..	29
<i>General</i> ... ..	11	<b>Testing</b>	
<i>Detailed procedure</i> ... ..	12	<i>General</i> ... ..	30
<b>Repair</b>		<i>Test equipment</i> ... ..	31
<i>Replacement of field coil brush leads</i> ... ..	13	<i>Schedule of Tests</i>	
<i>Repair of field coil lead insulation</i> ... ..	14	<i>Starting test</i> ... ..	32
<i>Armature</i> ... ..	15	<i>Gland leakage checks</i> ... ..	33
<i>Helicoil inserts</i> ... ..	16	<i>Proof and calibration checks</i> ... ..	34
<i>Removal of light surface corrosion and scores</i> ... ..	17	<i>Insulation resistance test</i> ... ..	35
<b>Assembling</b>		<i>Dry test</i> ... ..	36
		<i>Dismantling for inspection</i> ... ..	37

## LIST OF TABLES

	Table		Table
<i>Special tools and test equipment</i> ... ..	1	<i>tolerances</i> ... ..	3
<i>Detailed examination of components</i> ... ..	2	<i>Proof and Calibration tests</i> ... ..	4
<i>Schedule of fits, clearances and repair</i>		<i>Faults, possible causes and remedies</i> ... ..	5

## LIST OF ILLUSTRATIONS

	Fig.		Fig.
<i>Exploded view of pump and motor unit components</i> ... ..	1	<i>Circuit diagram—determination of brush gear geometric neutral axis</i> ... ..	5
<i>Brush spring pressure testing fixture</i> ... ..	2	<i>Running in fixture</i> ... ..	6
<i>Brush pre-bedding fixture</i> ... ..	3	<i>Shaft end-loading tools</i> ... ..	7
<i>Retardation fixture</i> ... ..	4		

~~RESTRICTED~~

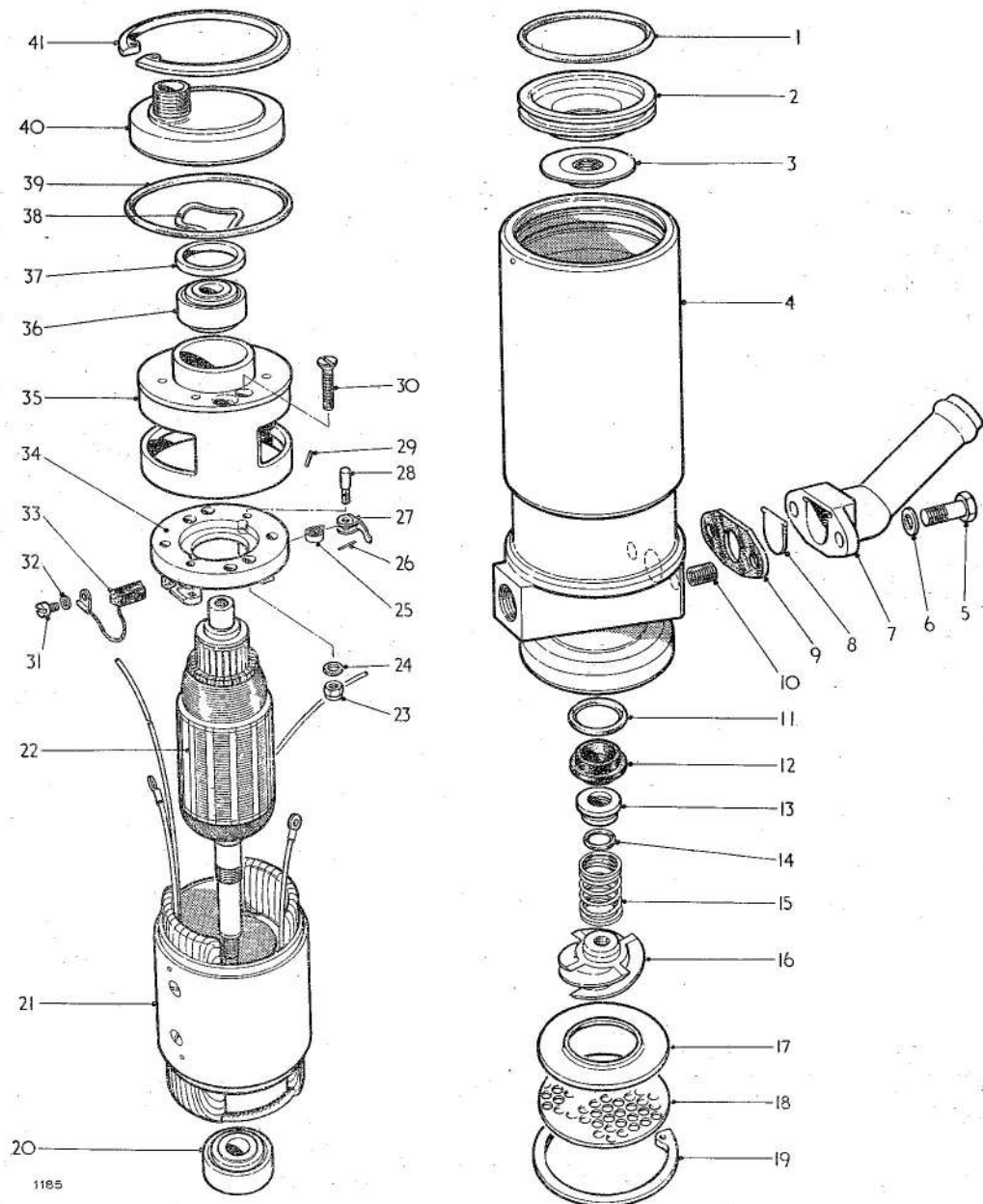

Fig. 1. Exploded view of pump and motor unit components

~~RESTRICTED~~

## Key to Fig. 1

1 'O' RING (13/16 in. i/d x 2 in. o/d x 3/32 in.)	23 4-B.A. SELF-LOCKING NUT	} BRUSH GEAR ASSEMBLY SECURING
2 LOWER BEARING HOUSING	24 4-B.A. PLAIN WASHER	
3 THROWER NUT	25 BRUSH SPRING	
4 PUMP BODY	26 SPINDLE SECURING WIRE	
5 10-32 UNF HEX. HD. BOLT	27 BRUSH FINGER	
	28 BRUSH SPRING SPINDLE	
6 2 B.A. WASHER	29 DOWEL PIN (MOTOR END CASING TO FIELD ASSEMBLY LOCKING)	
7 OUTLET CONNECTION ASSEMBLY	30 C/SK. HD. SCREW (BRUSH GEAR ASSEMBLY SECURING)	
8 FLAP VALVE	31 6-B.A. CH.HD. SCREW	} BRUSH SECURING
9 VALVE PLATE	32 6-B.A. SHAKEPROOF WASHER	
10 HELI-COIL INSERT (10-32 UNF x 0.380 in.)	33 BRUSH AND LEAD ASSEMBLY	
11 STATIONARY SEAL RING PACKING	34 BRUSH BOX CARRIER	
12 STATIONARY SEAL RING BODY	35 MOTOR END CASING ASSEMBLY	
13 ROTARY SEAL	36 UPPER BALL RACE	
14 'O' RING (5/16 in. i/d x 7/17 in. o/d x 1/6 in.)	37 THRUST RING	
15 SPRING (R.H.)	38 THRUST WASHER (3 off)	
16 IMPELLER HELIX	39 'O' RING (2 1/4 in. i/dia. x 2-7/16 in. o/dia. x 3/32 in.)	
17 VAPOUR GUIDE CONE	40 TOP COVER	
18 FILTER PLATE	41 BEVELLED CIRCLIP	
19 BEVELLED CIRCLIP		
20 LOWER BALL RACE		
21 FIELD ASSEMBLY		
22 ARMATURE ASSEMBLY		

## Introduction

1. The SPE.203 Mk. 2 fuel pump is designed to supply fuel under pressure to the aircraft engine driven pump and operates on a 26.5V d.c. aircraft supply. It is of the direct drive type with a single stage helical impeller and is completely submerged in the integral wing fuel tank. The pump is secured by metal straps to a structural member. Electrical and fuel delivery pipe connections are made within the tank.

2. Detailed instructions are given in this

chapter for the dismantling, repair, reconditioning and re-assembly of SPE.203 Mk. 2 pumps only. Later mark numbers will be covered by appendices to the chapter.

## RECONDITIONING

## Tools and test equipment

3. In addition to the standard bench tools, the special tools listed in Table 1 are required to overhaul SPE.203 Mk. 2 pumps. Details of the test equipment required are given in para. 31.

TABLE 1  
Special tools and equipment

Nomenclature	Part Number	Fig. No.
Circlip pliers (top cover and filter plate retaining)	Churchill 7065 Major	—
Special spanner (thrower nut and impeller removal and assembly)	T.2007	—
Brush spring pressure testing fixture	T.2092	2
Brush pre-bedding fixture	TD.198	3
Retardation fixture	T.1770	4
Special brush	SPE.20663	—
Locking piece	SPE.20306	—
Running-in fixture	T.2152	6
Calibrated fan	SPE.20483	—
Support block	T.2006/A	7
End-load fan	T.2006/B	7
Weights	T.2006/C-/F incl.	7

**RESTRICTED**

## DISMANTLING

### General

4. Refer to fig. 1. Ascertain whether the pump has been returned with a history sheet or other documents which will highlight points needing particular attention. Observe absolute cleanliness of workbench and tools. Use the special tools provided whenever specified.

### Removing the top cover

5. (1) Remove the bevelled circlip (41) from the pump body (4).
- (2) Withdraw the top cover (40). Discard the O-ring (39).
- (3) Remove the thrust washers (38) and thrust ring (37) located in the upper bearing housing.

### Withdrawing the impeller and seal assemblies

6. (1) Remove the bevelled circlip (19), filter plate (18), and vapour guide cone (17).
- (2) Use an Allen key in the upper end of the armature (22) to prevent shaft rotation and unscrew the impeller helix (16).
- (3) Remove the seal spring (15), rotary seal ring (13), stationary seal ring (12) and the stationary seal ring packing (11). Discard seal ring (11).
- (4) Withdraw and discard the seal ring (14) fitted in the internal groove of the rotary seal ring.
- (5) Remove the two bolts (5) and plain washers (6) to release the outlet connection assembly (7), valve plate (9) and flap valve (8).

### Withdrawing the motor unit

7. (1) Remove the cheesehead screws (31) and shakeproof washers (32) securing each brush assembly (33). Lift the brush fingers and withdraw the brushes.
- (2) Use an Allen key in the upper end of the armature to prevent shaft rotation and using the special key T.2007, unscrew the thrower nut (3) as far as possible.
- (3) Invert the pump and with the open upper end in the palm of the hand, push the motor unit carefully out of the casing by pressing on the lower end of

the armature shaft. After the first slight movement continue to release the thrower nut until it is free on the shaft. When the shaft is free of the thrower nut continue to apply even pressure to the end of the shaft until the motor unit is free of the pump body (4).

### Note . . .

*The lower bearing housing is not attached to the field assembly and may remain in the pump body when the motor unit is removed.*

- (4) Withdraw the armature assembly (22) from the end bearings, taking care not to damage the pole pieces of the field assembly.

### Dismantling the motor

8. (1) Separate the field assembly (21) from the motor end casing and upper ball race assembly, by removing pin (29). Do not attempt to further dismantle the field assembly.
- (2) Remove the self-locking nuts (23), plain washers (24) and countersunk head screws (30) securing the brush gear assembly to the motor end casing.
- (3) If it is necessary to dismantle the brush box assembly (see Table 2), remove the short length of copper wire (26) in each brush spring spindle (28). Tap the spindle out through the back of the brush box carrier (34) to release the brush spring (25) and finger (27). Do not attempt to further dismantle the brush carrier assembly.
- (4) Press the upper bearing (36) out of its housing in the motor end casing assembly (35).
- (5) If not withdrawn with the motor unit, press the lower bearing housing (2) out of the pump body (4) with any suitable drift. Discard the seal ring (1).
- (6) Press the lower bearing (20) out of its housing.

This completes the dismantling of the pump.

## CLEANING, EXAMINATION AND REPAIR

### Cleaning

9. The armature and field assembly should be cleaned with gasoline, no lead, using a bristle brush to dislodge all carbon deposits.

~~RESTRICTED~~

After cleaning, blow off surplus cleaning agent and allow the components to dry out for several hours, before completing the drying process in a ventilated oven at approximately 93 deg. C (200 deg. F).

**10.** All other parts other than the bearings and synthetic material or rubber components should be cleaned in a dry cleaning solvent or if excessively dirty in a heavy duty degreasant. After cleaning allow to dry out for 2 hours and complete the drying in a ventilated oven at approximately 93 deg. C (200 deg. F).

#### Examination

##### General

**11.** Examine all metal components visually for cracking, cleanliness, distortion, scoring,

denting, evidence of wear, deterioration of protective finishes (corrosion) serviceability of threads and thread inserts, security of sub-assemblies not dismantled (e.g. rivetting) and for deterioration due to overheating. Examine any re-usable rubber components and electric cable insulation for cleanliness, chafing, cracking, cuts, overheating, fluid soakage and general deterioration. All seal rings and locking devices must be renewed on re-assembly. It is also recommended that the bearings are renewed whenever the pump is overhauled.

##### Detailed procedure

**12.** Parts must be examined in accordance with Table 2 and checked for conformity with the Schedule of fits, clearances and repair tolerances detailed in Table 3.

**TABLE 2**

#### Detailed examination of components

Item	Inspection	Action if faulty
Armature	Insulation resistance to shaft. Use a 250-V insulation resistance tester Type C (Ref. No. 5G/152). Reading to be not less than 10 megohms.	Prolonged drying at 200 deg. F (93 deg. C) when thoroughly clean. Allow the armature to cool. Check that the insulation resistance is not less than 10 megohms. If below this figure, continue drying process. Cool. Re-check.
	Commutator for loose segments.	Reject for rewinding.
	Dirty commutator.	Clean with solvent (para. 9).
	Commutator for scoring and burnt segments.	Skim the commutator. The minimum permissible diameter for re-use is 19.5 mm (0.767 in.). The commutator to be true with shaft journals to within 0.001 in. (0.025 mm) total indicator reading. Undercut the micas 0.02 in. deep × 0.028/0.032 in. wide using a $\frac{3}{8}$ in. diameter cutter. Use very fine steel wool to rub off copper burrs.
	Fouling of the armature on the pole pieces of the field assembly.	Check shaft for concentricity and for excessive side play of bearings.
Short or open circuited conductors.	Clean the undercutting on the commutator. If still unsatisfactory, reject armature.	

~~RESTRICTED~~

TABLE 2—(contd.)

Item	Inspection	Action if faulty
	Armature shaft for concentricity.	Maximum eccentricity measured at ends of shaft 0.001 in. (0.025 mm) total indicator reading. The two bearing journals and the commutator must be concentric within 0.001 in. (0.025 mm) total indicator reading. If in excess, reject.
Field assembly	<p>Charring or other evidence of overheating.</p> <p>Resistance of windings:                      Shunt, 49.115 + 13% — nil ohms per coil.                      Series 0.080 + 10%, — nil ohms per coil.                      Total 98.390 + 13%, — nil.                      All measured at 20°C.</p> <p>Insulation resistance of coils to frame. Reading to be not less than 10 megohms.</p> <p>Condition of field coils.</p>	<p>Renew complete assembly.</p> <p>Renew complete assembly.</p> <p>Prolonged drying at 200 deg. F (93 deg. C) when thoroughly clean. Allow the assembly to cool. Check the insulation resistance. If below the minimum figure continue the drying process. Cool. Re-check.</p> <p>If the coils are damaged, renew the complete assembly. If the leads are damaged, cover with additional sleeving as detailed in para. 13-14.</p>
Brush gear	<p>Fit of brushes in brush boxes.</p> <p>Chipping.</p> <p>Frayed pigtail leads.</p>	<p>Brushes must slide freely in the brush boxes. Carbon dust collected in the corners of the brush boxes must be removed.</p> <p>Reject, or if very slight, re-bed.</p> <p>Reject.</p>
Brush springs	Spring pressure to be 0.16 lb. ± 0.016 lb. (66/80 g) on contact surface.	Adjust spring by rotating spring spindle.
Seal assembly	Scoring of seal faces.	If slight, relap to a mirror finish. If excessive, renew components as necessary.
Seal spring	Check characteristics. Load to be 1.25 lb. ± 5% at working length 0.708 in.	Reject.
Bearing pre-load washer	Washer to exert load of 7.75 lb. ± 15% when depressed to height of 0.035 in.	Reject.

~~RESTRICTED~~

TABLE 3

## Schedule of fits, clearances and repair tolerances

Part & description	Dimensions new	Permissible worn dimension for re-use	Clearance new	Permissible worn clearance for re-use	Remarks
MOTOR UNIT— BRUSH LENGTH overall	0.413 in. (10.5 mm.)	0.366 in. (9.3 mm.)	—	—	—
COMMUTATOR dia.	20.3 mm. 20.4 mm. (0.798 in.) (0.803 in.)	19.5 mm. (0.767 in.)	—	—	—
ARMATURE— END FLOAT	—	—	0.002 in. 0.003 in. (0.05 mm.) (0.075 mm.)	0.002 in. 0.003 in. (0.05 mm.) (0.075 mm.)	See assembly instructions for adjustment details
ARMATURE SHAFT IN DRIVE-END BALL-RACE shaft dia.  race bore	8.995 mm. 8.985 mm. (0.3541 in.) (0.3537 in.) 9.000 mm. 8.993 mm. (0.3543 in.) (0.3540 in.)	—	—	—	Inner race clamped to shaft on both faces
DRIVE-END BALL RACE IN HOUSING race dia.	26.000 mm. 25.993 mm. (1.0236 in.) (1.0233 in.)				

~~RESTRICTED~~

TABLE 3—(contd.)

Part & description	Dimensions new	Permissible worn dimension for re-use	Clearance new	Permissible worn clearance for re-use	Remarks
housing bore	26-009 mm. 26-019 mm. (1-0240 in.) 26-019 mm. (1-0240 in.) 26-019 mm. (1-0240 in.)				
ARMATURE SHAFT IN UPPER BALL RACE shaft dia.	8-995 mm. 8-985 mm. (0-3541 in.) 8-985 mm. (0-3537 in.)	—	—	—	—
race bore	9-000 mm. 8-993 mm. (0-3543 in.) 8-993 mm. (0-3540 in.)				
UPPER BALL RACE IN HOUSING race dia.	26-000 mm. 25-993 mm. (1-0236 in.) 25-993 mm. (1-0233 in.)	—	—	—	—
housing bore	26-000 mm. 26-01 mm. (1-0236 in.) 26-01 mm. (1-0240 in.)				

**Repair**

*Replacement of field coil brush leads*

13. (1) Cut back the damaged lead to within  $\frac{1}{2}$  in. of the coil, bare the ends of the old and the new P.T.F.E. insulated cable (19/0076 in.—white) for  $\frac{3}{8}$  in. and clean the wires. Interlock strands, twist half a turn and bind with one strand of wire from the cable.

(2) Solder the joint and coat with an

approved rubber sealant (e.g. P.R. 1005L). Cover the joint itself with a  $\frac{3}{8}$  in. long rubber sleeve and this sleeve and the leads on both sides of the joint with a 1 in. long sleeve.

*Repair of field coil lead insulation*

14. (1) If damaged to within 1 in. of the coil, cover the damaged area with a Helsyn rubber sleeve.

~~RESTRICTED~~

(2) If the damage is more than 1 in. from the coil, cover the whole lead with fibre glass sleeving and secure at each end with a 1 in. long rubber sleeve.

(3) In (1) and (2) above secure the sleeves with a suitable sealant (e.g. P.R.1005L).

#### Armature

**15.** (1) If scored, the commutator must be lightly skimmed ensuring that the final diameter is not less than that detailed in Table 3. The surface must be very fine and free from all tool marks. Check concentricity with shaft journals after machining. Eccentricity must not exceed 0.001 in. total indicator reading.

#### Note . . .

*Emery cloth and glass paper should not be used as particles of abrasive may become embedded in the soft copper and lead to very rapid brush wear.*

(2) After machining the commutator surface paint the surface for a distance of  $\frac{1}{16}$  in. from the riser with I.C.I. anti-tracking paint Ref. 338-2026 (Red).

(3) If after skimming the commutator the micas are found to be less than 0.35 mm (0.014 in) below the commutator surface, they must be undercut to the dimensions stated in Table 3. Check that no mica fragments have been left between the segments and remove all burrs from the segments by light application of very fine steel wool.

(4) Check that the armature runs true with the shaft throughout its length to within 0.001 in. total indicator reading.

#### Helicoil inserts

**16.** Thread inserts are positioned at the fixing positions for the outlet connection assembly (7). Examine each and if in need of replacement remove the insert with the special tool supplied by the insert manufacturer. To fit a new insert, lightly coat the outside of the insert with zinc chromate inhibiting compound to Spec. 369 (e.g. Cello-seal) and while the compound is still wet, screw in the new insert using the appropriate tool.

#### Removal of light surface corrosion and scores

**17.** (1) Light surface corrosion or scores may be removed with a polishing hone or grade 00 carborundum cloth.

(2) Clean off all traces of abrasive.

(3) Treat the affected areas with an approved anti-oxidant (e.g. Zix-O or alchromate solution) immediately.

### ASSEMBLING

#### General

**18.** Maintain absolute cleanliness of workbench and tools throughout the assembly of the pump. Retain the bearings in their wrappings until they are required for assembling. Check the availability of the special tooling required to assemble the pump (see Table 1). All un-anodised surfaces in contact with one another must be free from oxidation on assembly, and after cleaning must be immediately treated with an approved anti-oxidant (e.g. Zix-O or alchromate solution).

#### Brush holder assembly

**19.** (1) Position the brush spring (25) in the brush finger (27) and hold in position inside the brush holder.

(2) Insert the brush spring spindle (28) from the back of carrier (34) locating the centre arm of the spring in the spindle slot.

(3) Before locating the square section of the spring spindle in the holder, grip the end of the spindle and tighten the spring by twisting through 90 degrees. Locate the spindle square-section in the holder.

(4) Check the brush spring loading as follows:

(a) Fit a plug to the fixture T.2092 (fig. 2) of the same nominal diameter as the commutator (see Table 3). Fit the brush gear to the fixture and slip into the brush box the special fibre brush with centre conductor rod. This brush should be of the same dimensions as a new brush (33).

**RESTRICTED**

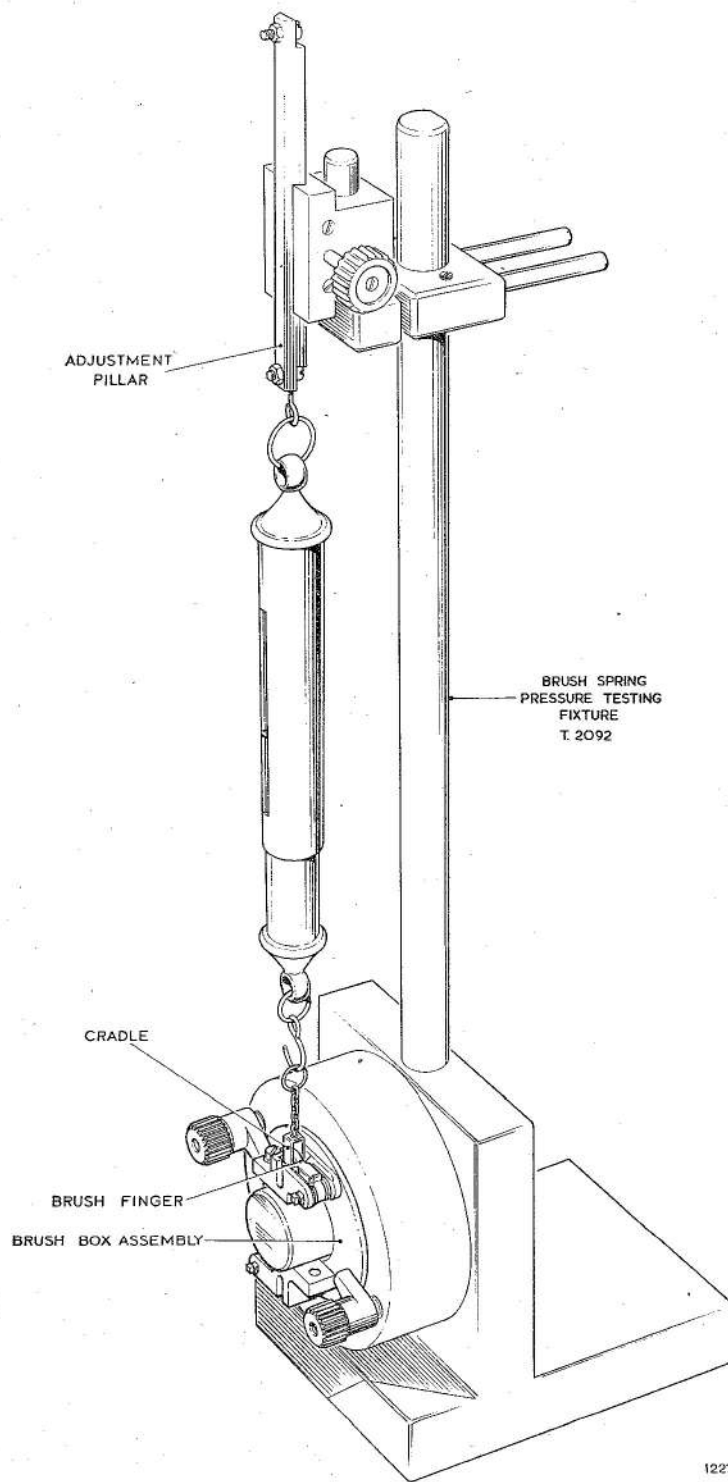

Fig. 2. Brush spring pressure testing fixture

~~RESTRICTED~~

(b) Hook the small cradle attached to a spring balance under the brush finger (27).

(c) Connect a battery and lamp between the brush carrier and centre plug so that when the spring balance is lifted the exact loading at which the brush spring finger lifts will be indicated by the lamp switching off.

(d) Tension each brush spring so that the load (indicated by the spring balance) is 0.16 lb.  $\pm$  10 per cent.

(5) If the spring pressure conditions are not satisfied, tighten the spring a further quarter of a turn and recheck. If the pressure is now excessive, reject the spring. Fit a new spring and recheck.

(6) When the spring pressure is set within the limits, insert a short length of 21 S.W.G. copper wire (26) through the spindle hole and bend back each end to lock.

(7) Repeat the above procedure for second brush spring.

#### Assembling the brush gear

20. (1) Position the brush gear assembly in the motor end casing assembly (35).

(2) Secure with two countersunk head screws (30), plain washers (24) and self-locking nuts (23).

#### Assembling the upper bearing

21. (1) Select a bearing (36) that is a firm slide fit under thumb pressure both on the armature shaft and in the motor end casing (35). Check that the bearing is smooth running with no roughness of the tracks when the inner race is rotated by hand.

#### Note . . .

*Retain the armature and suitably mark it so that it can be paired with the selected bearing at a later assembly.*

(2) Insert the selected bearing into the top casing.

#### Pre-bedding the brushes

22. (1) Assemble the top casing sub-assembly as para. 21 to the special

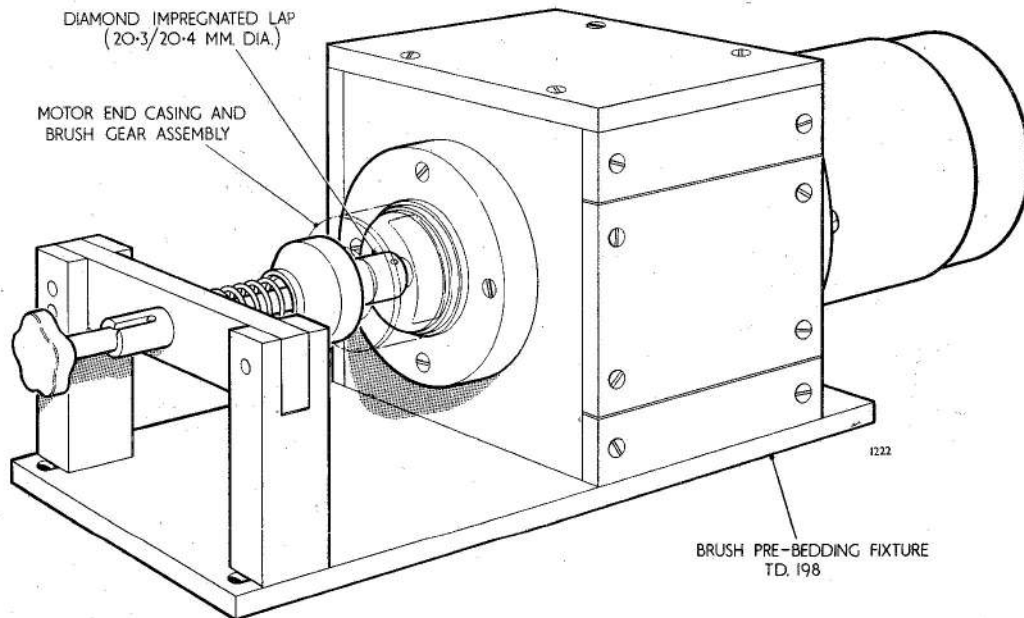

Fig. 3. Brush pre-bedding fixture

**RESTRICTED**

brush bedding fixture TD.198, fig. 3. Lift the brush fingers and insert a brush into each box. Secure with cheesehead screws (31) and shakeproof washers (32). Tighten the end cap of the brush bedding fixture.

(2) Connect a 26V d.c. supply to the slave motor and run for a minimum period of 2 minutes or until the brushes are bedded over their full width of arc with at least 80 per cent of their face areas making contact with the diamond impregnated lap. The running time will depend in part on the length of time that the lap has been in use.

(3) Remove the brush gear assembly from the fixture, taking care not to chip the brushes. Remove each brush and identify it with the box in which it was fitted.

(4) Clean out all carbon dust from the brush boxes with dry compressed air.

#### Assembling the lower bearing

23. (1) Select a bearing (20) that is a firm press fit under thumb pressure both on the armature shaft (22) previously selected (para. 21) and in the lower

bearing housing (2). Check that the bearing is smooth running with no roughness of the tracks when the inner race is rotated by hand.

(2) Suitably identify the selected bearing with its housing. Press the bearing onto the drive-end of the selected armature assembly.

#### Motor speed setting

24. (1) The motor speed must be set by finding its geometric neutral axis. To determine the geometric neutral axis, proceed as detailed below.

#### Note . . .

*On SPE.203 Mk. 2 pumps the lower bearing housing is not attached to the field assembly and the motor unit cannot be handled as a separate assembly. Use must be made of a fixture to hold the parts in their correct positional relationship during the determination of the brush gear geometric neutral axis.*

(2) Assemble the field assembly (21) with the field coil leads uppermost into

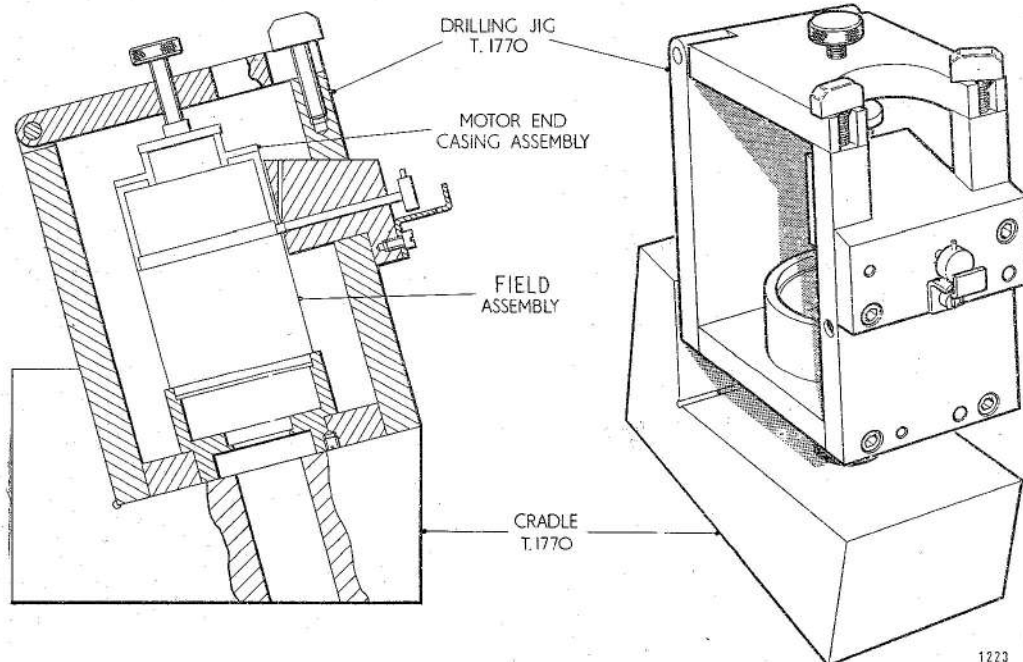

Fig. 4. Retardation fixture

**RESTRICTED**

the retardation fixture T.1770 (fig. 4). Carefully pass the armature assembly through the bore of the field assembly and locate the bearing in the fixture housing.

(3) Carefully position the motor end casing and brush gear assembly on the field assembly and rotate until the small slot in the lower edge of the top motor end casing assembly (35) is in line with the locking key in the central block of the fixture. Press this key forward into the slot to lock the end casing in position.

(4) Position a thrust ring (37) and three thrust washers (38) on the upper bearing (36) of the motor unit. Lower the hinged top plate of the fixture and secure with the two screws. Tighten the central knurled thumbscrew so that the retaining plate is tight against the top face of the motor end casing.

(5) Insert a special brush SPE.20663 in one brush box and the locking piece SPE.20306 in the opposite box. Secure the special brush with a cheesehead screw (31) to the brush terminal tapping. Note that the end of the locking piece must locate in a commutator slot to prevent rotation of the armature.

(6) Connect up the circuit as illustrated in fig. 5 with the field leads connected to the oscilloscope and with the resisted input across the special brush as indicated.

(7) Switch the oscilloscope time base to a frequency much higher than the 2.5V supply frequency so that a rectangular trace is obtained on the oscilloscope. Slacken the fixture thumbscrew slightly so that the field assembly can be rotated until the trace attains maximum amplitude (vertical displacement) or overload. Manipulate the Y

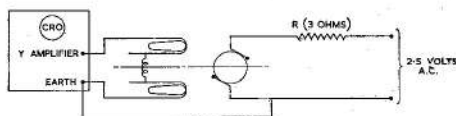

Fig. 5. Circuit diagram—determination of brush gear geometric neutral axis

amplifier gain control bringing the amplitude of the trace to just below overload. If overload is not obtained the Y amplifier should be set at full gain and left at this setting.

(8) Rotate the field assembly until the narrowest possible line is displayed on the oscilloscope. Continue rotation until the width of line increases, reverse the direction of rotation and continue until the narrowest line is again obtained. Mark the position of the field assembly relative to the top motor end casing (35).

(9) Rotate the armature through 90 degrees and determine the geometric neutral axis at the new position by the method detailed in sub-para. (7)-(8). Mark the motor casing in line with the original datum on the field assembly. Repeat twice more at 90 degree intervals of armature rotation. Align the original datum on the field assembly with the mean of the four marks on the motor casing.

(10) Repeat the process detailed in sub-para. (7)-(9) with the positions of the special brush SPE.20663 and the locking piece SPE.20306 reversed. Align the original datum on the field assembly with the mean of the two means now marked on the motor end casing. Remove the special brush and locking strip.

(11) Ensure that the relative position of the field assembly and top motor end casing are not altered. Transfer fixture T.1770 to the angled cradle, withdraw the locking key of the fixture and drill through the guide block hole into the field assembly to a depth of 7 mm (0.275 in) using a  $\frac{1}{16}$  in. diameter drill. Fit the pin (29) and finish flush with the field casing diameter.

(12) If necessary turn the field assembly through exactly 180 degrees to avoid drilling into the existing dowel pin hole.

#### Brush bedding motor run

25. (1) Carefully remove the motor unit components from the fixture T.1770 and

**RESTRICTED**

transfer to the running-in fixture T.2152 (fig. 6). Take care not to damage the armature assembly which is free within the field and end casing assembly. Ensure that the thrust ring and washers are in position when the end thumbscrew of the fixture is used to clamp the components together.

(2) Return the brushes removed after pre-bedding (para. 22) to their original boxes as indicated by the identification marks. Secure the brushes and field coil leads with cheesehead screws (31) and shakeproof washers (32).

(3) Run the motor on no load at 17-18V d.c. input until the brushes bed over their full width of arc with at least

80 per cent of their face area making contact with the commutator. Remove the brushes, clean out all carbon dust with dry compressed air, and refit.

**Note . . .**

*Ensure that the brushes are returned to their correct brush boxes after cleaning.*

(4) Using the calibrated fan SPE. 20483 run the motor unit on load for 20 minutes at 26.5V d.c. input. Check that the motor speed is not less than 6970 rev./min. and that current consumption does not exceed 2.75A. No adjustment of the brush box position to attain this performance is permissible.

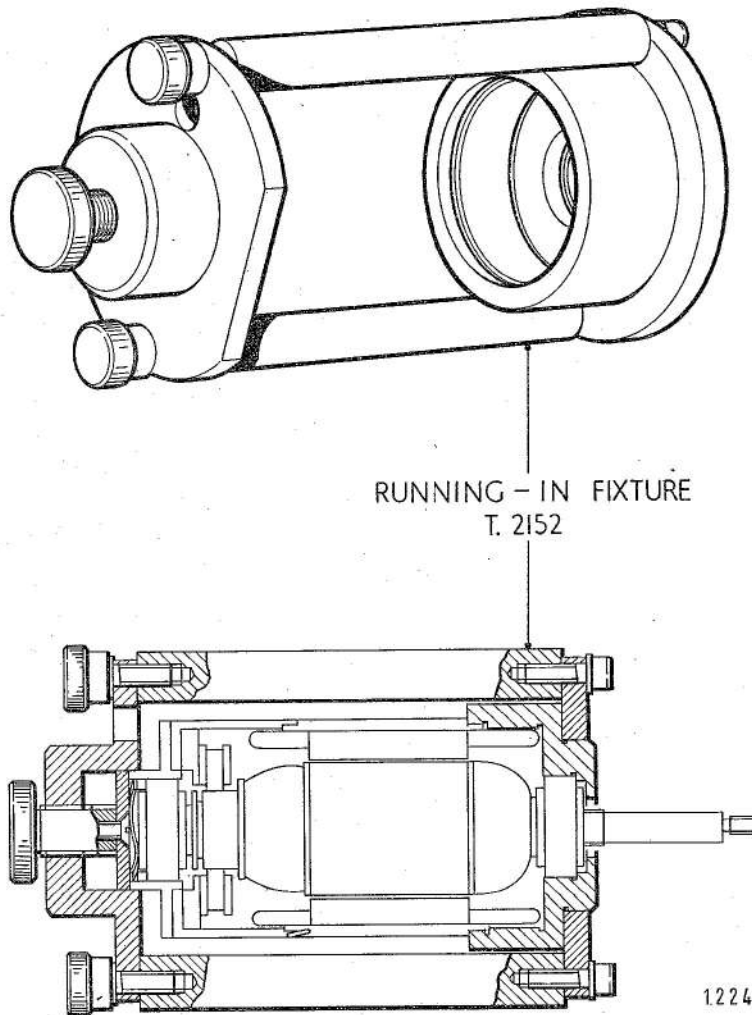

**Fig. 6. Running in fixture**

**RESTRICTED**

(5) With the motor unit still running under load make a visual check of the sparking at the brushes. Commutation is satisfactory if either continuous or intermittent blue sparking or no sparking is observed. Sparking in which there are intermittent or continuous yellow flashes is unacceptable.

#### Transferring the motor unit components to the pump body

26. (1) Carefully remove the motor unit components from the fixture T.2152 but identify each to ensure that they are all built into the same pump unit. Keep the armature in position if possible, but if removing, first withdraw the brushes from the brush holders.
- (2) Thread the mains supply leads (length 5ft. 3 in.) through the motor end casing and solder to the loop connections on the field assembly (21) using a high melting point solder.
- (3) Fit a new seal ring (1) in the lower bearing housing (2).
- (4) Fit the bearing housing (2) to the

bearing on the armature shaft and loosely assemble the thrower nut (3).

(5) Invert the motor end casing and field assembly so that it stands on the upper bearing housing. Carefully lower the armature assembly through the bore of the field and brush gear assemblies, locating the end of the shaft in the bore of the upper bearing. Take care not to damage the armature laminations on the pole pieces of the field assembly or to score the commutator on the brush boxes.

(6) Lift the brush fingers (27) and slip the brushes back into the boxes.

(7) Draw the mains supply leads tight so that they are taut within the motor end casing.

(8) Lubricate the lower bearing housing seal ring (1) with a smear of Silicone MS4 compound A.339 (Ref. No. 33C/9424829). Carefully lower the pump body (4) over the motor unit assembly until the lower bearing housing is located.

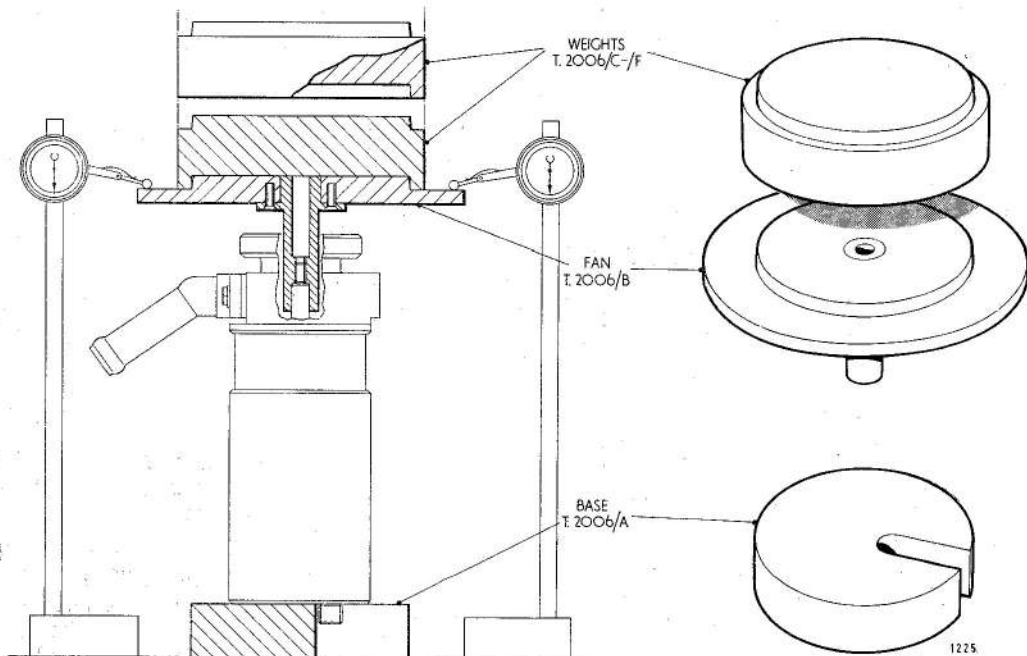

Fig. 7. Shaft end-loading tools

**RESTRICTED**

### Adjusting the shaft end loading

27. (1) Fit a special thrust ring (37) that has been reduced in thickness to approximately 0.080 in.

(2) Position three thrust washers (38) on this special thrust ring, fit a top cover (40) and retain with the circlip (41).

(3) Invert the pump assembly, standing on the block T.2006/A to give clearance to the electrical conduit union on the top cover.

(4) Screw the fan T.2006/B on to the impeller thread of the motor shaft. Arrange two dial gauges diametrically opposite to one another as illustrated in fig. 7, so that they register near the outer edge of the fan.

(5) Zero the dial gauges. Use the weights T.2006/C/D/E/F in combination to apply a load of 32-34 lb. to the face of the fan and check the true axial movement under this load (indicated by identical deflection of both dial gauges). The required axial movement is 0.002 in./0.003 in.

(6) Let the true axial movement obtained using the special thrust ring (sub-para. 1) be X. Then to obtain the required 0.002 in./0.003 in. axial movement a thrust ring (37) should be machined to a thickness equal to A in. + (X - 0.0025 in.). Where A is the actual thickness of the special thrust ring.

Example:

A (thickness of special thrust ring) ... 0.077 in.  
X (total axial movement under load 32/34 lb.) ... 0.024 in.  
Then thickness of thrust ring to be fitted = 0.077 in. + (0.024 in. - 0.0025 in.) = 0.0985 in.

(7) Remove the top cover and special thrust ring. Retain the thrust washers (38).

(8) Fit a new seal ring (39) in the internal groove of the pump body (4). Smear with Silicone MS4 compound A.339.

(9) Fit a thrust ring (37) machined to the thickness determined in sub-para. (6). Re-position the three thrust washers (38), replace the top cover (40) and retain with the circlip (41).

(10) Invert the pump, replace and zero the dial gauges. Check that under a load of 32-34 lb. the true axial movement of the shaft is 0.002 in./0.003 in.

(11) Add additional weights T.2006/C/D/E or /F until a true axial movement of at least 0.015 in. is obtained to ensure that the thrust washers (38) are not compressed solidly.

(12) Remove the fan T.2006/B. Use the special spanner T.2007 to securely tighten the thrower nut (3).

### Assembling the seal and impeller

28. (1) Fit the stationary seal ring packing (11) to the stationary seal ring body (12).

(2) Using a collet-type tool to hold the components, position so that the packing ring seats in the central recess of the pump body.

(3) Fit a new 'O' ring (14) in the internal groove of the rotary seal ring (13), lightly smearing with Silicone MS4 compound A.339. Insert the seal ring and position the spring (15) over the rotary seal ring (13) so that it bottoms against the shoulder and locates the components on the shaft.

(4) Screw on the impeller helix (16), locating the seal spring over its central spigot, until it bottoms against the shaft shoulder.

### Completing the pump assembly

29. (1) Position the vapour guide cone (17) and filter plate (18) and retain with the circlip (19).

(2) Position a flap valve (8) in the shaped recess of the outlet connection (7). Position a valve plate (9) on the pump body (4) and secure the outlet connection sub-assembly to the pump body with the two hexagon head bolts (5) and plain washers (6).

Note . . .

*The outlet connection should be assembled so that the outlet tube is angled upwards.*

(3) The pump is now ready for acceptance testing (para. 32-35). If this testing is not to be carried out immediately, fit transit plugs to the gland drain, inlet, outlet and electrical supply union.

~~RESTRICTED~~

**TESTING****General**

**30.** The complete pump must be tested in accordance with the Schedule of Tests detailed in para. 32-35. The pump must be rejected if it fails to comply with these tests.

**Test equipment**

**31.** The pump should be tested using the Universal test rig 5G/3494, modified to allow the pump to be strapped to a support member within and close to the bottom of the tank. All tests are to be carried out using AVTUR fuel (Spec. D.Eng.R.D.2482). Fuel temperature must be maintained between 15 deg. C and 28 deg. C and a fuel head as specified maintained above the base of the pump inlet flange.

**Schedule of tests***Starting test*

**32.** With the pump fully primed under a 12 in. head of fuel and the test circuit delivery valve closed, the pump must start satisfactorily when 12V d.c. is applied for a maximum time of 3 seconds. If the pump starts satisfactorily, switch off and repeat the test four times. If the pump fails to start it must be rejected.

*Gland leakage checks*

**33.** With the pump stationary and fully primed under a 9 in. head of fuel, apply a superimposed air pressure of 10 lb/in<sup>2</sup>. for 15 minutes over the fuel. Repeat this test with 29V d.c. applied to the motor unit and with the test circuit delivery valve closed. During both tests observe for:

- (a) fuel leakage from the gland drain.
- (b) external leakage of fuel.

The maximum allowable leakage from the gland drain during the period of the stationary test is 0.25 cc and during the period of the running test 0.5 cc. Any other external leakage is not permissible.

*Proof and calibration tests*

**34.** (1) Run the pump for 1 hour under a 9 in. head of fuel at 24V d.c. input and with the test circuit flow control valve set at 300 gal/hr. Record the motor current at the beginning and end

of the test and check that it is within the limits specified in Table 4.

(2) Adjust the voltage to 26.5V d.c. and maintain the flow at 300 gal/hr. Record the motor current and delivery pressure and check that they are within the limits specified in Table 4.

(3) Adjust the voltage to 29.0V d.c. and maintain the flow at 300 gal/hr. Run the pump for 1 hour under these conditions and record the motor current at the beginning and end of the test run, and check that it is within the limits specified in Table 4.

*Insulation resistance test*

**35.** Using an insulation resistance tester Type C, measure the insulation resistance between each supply lead and the pump casing. The minimum reading obtained must be not less than 0.5 megohm.

*Dry test*

**36.** The pump must be mounted clear of fuel and run for 5 minutes only on an applied voltage of 29.0V d.c. Record the current consumption at the beginning and end of the test, and check that it is not greater than 2.0A finally.

*Dismantling for inspection*

**37.** Dismantling must be reduced to an absolute minimum in the case of a pump which has satisfactorily completed the above tests. No attempt should be made to break joints already thoroughly tested. Should the authorised inspector consider that a major strip for examination is necessary, the pump on rebuild must be subjected to a repeat of all the above tests.

**TABLE 4****Proof and calibration tests**

Volts (d.c.)	Flow (gal/hr.)	Delivery pressure (lb/in <sup>2</sup> .)	Current A (max)
24.0	300		3.0
26.5	300	2.0	3.5
29.0	300		4.0

**~~RESTRICTED~~**

**TABLE 5**

**Faults, possible causes and remedies**

**Motor Unit only:**

Fault	Possible cause	Remedy
Sparking at commutator.	(1) Brush sticking in brush guides.	Clean brush faces and inner surfaces of brush box. If brush still sticks rub sides lightly with grade 000 glasspaper.
	(2) Brush incorrectly bedded.	See assembly instructions.
	(3) Insufficient brush spring pressure.	Check that the brush spring fingers are locating correctly on the ends of the brush and are not lodged on the brush boxes. Check spring characteristics (see Table 2).
	(4) Badly chipped brush.	Renew. Check that the reason for chipping is not a high commutator segment.
	(5) Brushes too short.	See Table 3 for permissible worn dimension for re-use.
	(6) Dirty commutator.	See Table 2.
	(7) Unequal current distribution between brushes.	Check for loose connections or pigtail leads.
	(8) Loose brush box.	Renew.
	(9) Proud micas.	
	(10) Shoulders or flats on commutator.	See Tables 2 and 3.
	(11) Excessive commutator eccentricity.	
	(12) High armature current.	Check security of connections. If caused by overload, a weak field or short circuit, renew parts as necessary.
	(13) Faulty armature winding.	Check by voltage drop method. Renew if fault confirmed.
Low torque.	(1) Excessive friction.	Check that the armature is not fouling the field laminations.
	(2) Open circuit or high resistance in the field circuit.	Check connection for tightness and windings for continuity.
	(3) Dirty commutator.	See Table 2.

~~RESTRICTED~~

TABLE 5—(contd.)

Fault	Possible cause	Remedy
Overheating.	(1) Low insulation resistance.	Blow out all carbon dust with dry compressed air. Dry for prolonged period at 200 deg. F (93 deg. C). Allow to cool. Check that insulation resistance is not less than 0.5 megohms. If below this figure continue drying process.
	(2) Faulty field circuit.	Examine all connections for cleanliness and tightness.
	(3) Faulty bearings.	Check fits (Table 3).
High motor speed.	Weak field.	Check all connections.
Low motor speed.	(1) Faulty armature winding.	Check by voltage-drop method. Renew if fault confirmed.
	(2) Excessive friction.	See Low torque (1).
Motor fails to start.	(1) No supply.	Check voltage to mains supply leads.
	(2) Excessive friction.	See Low Torque (1).
	(3) Open circuit.	Remove armature and check by voltage-drop method. Check field circuit for continuity.
	(4) Short circuit in field coils.	If due to dampness, dry out as detailed in Table 2. If for other reasons, renew the field assembly.
	(5) Brush not bedded properly.	See "Sparking at Brushes".

**Complete pump**

Dismantling and re-assembling the pump and motor unit to rectify any fault should be carried out in accordance with the instructions detailed in para. 5-29.

Gland leakage.	(1) Bad finish between seal faces.	Remove and relap.
	(2) Cracked stationary seal ring body.	Renew.

~~RESTRICTED~~

TABLE 5—(contd.)

Fault	Possible cause	Remedy
Excessive motor current.	(1) Faulty motor unit.	Check conditions of brushes and commutator (see Table 2 and 3).
	(2) Fouling of impeller by foreign matter.	Dismantle and examine for obstructing material. If undamaged, clean and refit.
	(3) Faulty bearings: pump is stiff to turn and an intermittent jerky resistance is felt when pump shaft is rotated.	Check that the bearings are free turning. Dismantle pump and renew if necessary.
Excessive current consumption but armature free to turn and pump will not start.	Faulty coils.	Check field coils for continuity.
Very high current consumption.	Short circuit.	Check insulation resistance between one pole and motor frame. Check leads for chafing.
Low or fluctuating current consumption.	Dirty commutator and brushes.	Dismantle and clean. Re-bed brushes on re-assembly.
	Grease leakage from commutator end bearing making brushes 'stick'.	Renew faulty bearing. Clean the brushes and commutator.
Low delivery pressure.	Faulty motor.	Check motor speed and brush gear setting. Adjust if necessary.
	Impeller impedance.	Examine for obstruction. Check clearance.
Pressure surge.	Tight or pre-loaded bearings.	Check fits (Table 3). Renew as necessary.
Low insulation resistance.	Dampness in motor windings.	Prolonged drying of armature and field at 200 deg. F (93 deg. C).

**RESTRICTED**

This file was downloaded  
from the RTFM Library.

Link: [www.scottbouch.com/rtfm](http://www.scottbouch.com/rtfm)

Please see site for usage terms,  
and more aircraft documents.

