

CANCELLEDDo NOT DESTROY
A.P.4343D, Vol. 6, Book 2, Sect. 7, Chap. 9
A.L.134, Nov. 65

Chapter 9

PUMP, FUEL, ADEL TYPE 70373

LIST OF CONTENTS

	Para.		Para.
<i>Introduction</i>	1	<i>Repair</i>	8
<i>Tools and test equipment</i>	2	<i>Assembling</i>	11
<i>Dismantling</i>	3	Testing	
Cleaning, inspection and repair		<i>Motor</i>	12
<i>Cleaning</i>	4	<i>Pump</i>	15
<i>Examination</i>	5		

LIST OF TABLES

	Table
<i>Performance test</i>	1
<i>Calibration test</i>	2

LIST OF ILLUSTRATIONS

	Fig.
<i>Section view of pump and motor</i>	1
<i>Exploded view of motor</i>	2
<i>Slinger remover</i>	3
<i>Shim installation details</i>	4

Introduction

1. A general description of the Adel Type 70373 fuel booster pump is given in A.P. 4343D, Vol. 1, Book 2, Sect. 7, Chap. 9.

Tools and test equipment

2. Apart from the normal hand tools generally used, the only special tools are two slinger removers (fig. 3), manufactured from strip steel.

Dismantling

3. The pump should be removed in the following sequence:—

(1) Cut the locking wire, remove the three screws, washers and throat from the pump body. Remove and discard

the packing. Remove the shims and record their thickness.

(2) Wedge the impeller with a piece of hardwood and remove the self-locking nut and plain washer. Remove the wedge and withdraw the impeller from the armature shaft. Remove the key from the keyway in the shaft.

(3) Remove the shims from between the impeller and driver and record their thickness. Remove the driver, spring and rotating seal from the armature shaft.

(4) Remove and discard the packing from the armature shaft. Remove the stationary seal and discard its packing.

~~RESTRICTED~~

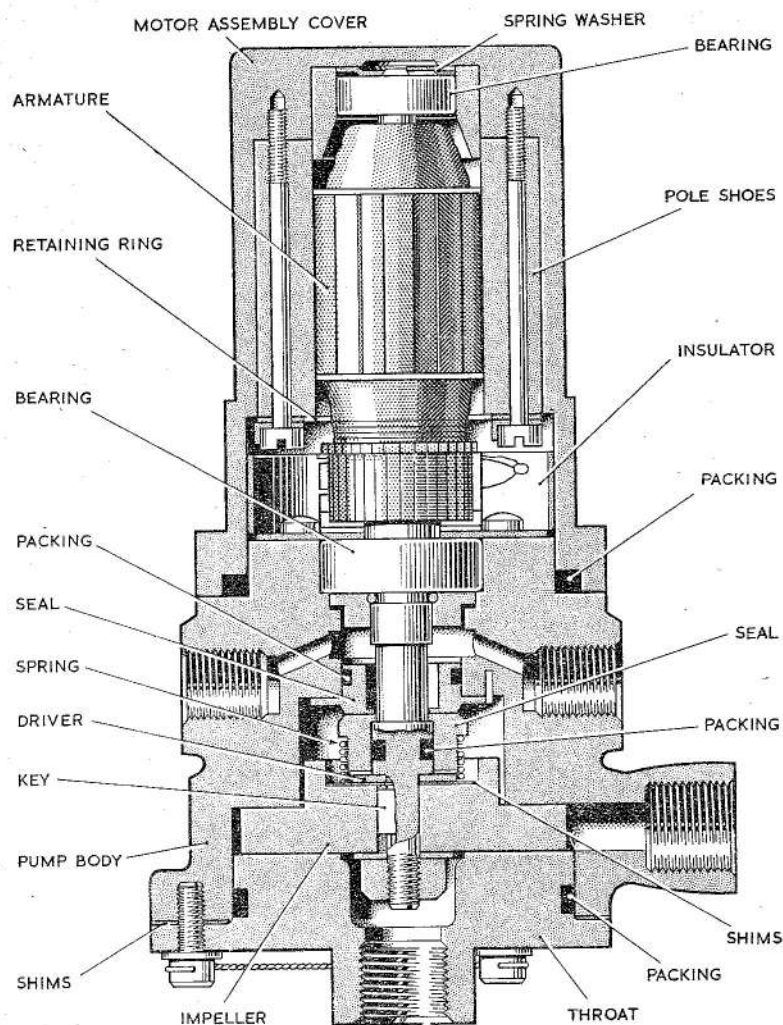

Fig. 1. Section view of pump and motor

Note . . .

If any difficulty is experienced in removing the stationary seal, it can be left to follow the removal of the armature assembly from the pump body.

(5) Cut the locking wire, remove the four screws and plain washers and lift the cover from the pump body. Remove and discard the packing from between the cover and pump body. Remove the insulator and loading spring washer from within the cover.

(6) Disconnect the leads; remove the retaining ring and grommet and with-

draw the leads from the pump body.

(7) Remove the four screws from the brush holder plate assembly and lift the armature assembly complete (fig. 2) from the pump body.

(8) Remove the cotter pins, brush springs and brushes from the brush plate assembly. Mark each brush so that it can be refitted into its same brush holder.

(9) Remove the slinger, using the tool shown in fig. 3. Remove the retaining ring. Using the appropriate bearing extractor, remove the bearings. Lift off the plate assembly.

~~RESTRICTED~~

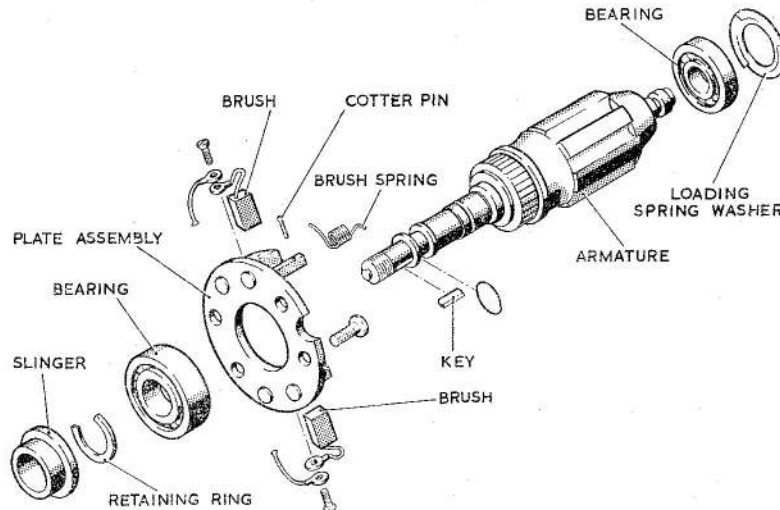

Fig. 2. Exploded view of motor

CLEANING, INSPECTION AND REPAIR

Cleaning

4. Wash all non-electric parts, except bearings, in a lead-free gasoline and dry thoroughly with clean dry compressed air or a lint free cloth. Stubborn obstructions should be removed from bores and crevices using a stiff bristle brush. Remove all surface dirt from electrical parts using a clean lint free cloth moistened with lead-free gasoline.

Examination

5. Visually examine all metallic parts for breaks, cracks, scoring, corrosion, distortion, worn plating, pitting, stripped or crossed threads or any other defects.

Pump

6. Examine the inner surfaces of the throat and pump body for nicks, deep scratches or roughness which might indicate fouling of the impeller caused by worn bearings or distorted pump assembly. Examine the stationary and rotating seals under magnification for condition of contact areas. Examine the seal retaining pin for signs of damage.

Motor

7. Examine the armature for burned or

scratched laminations and any other signs of visible damage. Examine the armature shaft in the vicinity of the bearings for signs of heating or wear. Examine the brush holder plate for security of its parts and freedom from damage. Examine the brushes for burnt, scratched, chipped or unevenly worn armature contact surfaces.

Repair

8. Replace all parts which are cracked, worn, distorted or damaged beyond repair. All packings must be replaced at each overhaul. It is recommended that all bearings be changed at each overhaul.

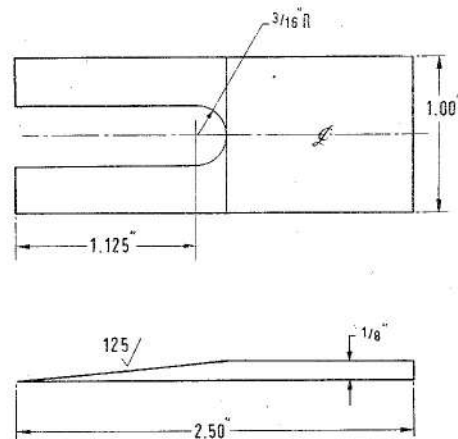

Fig. 3. Slinger remover

RESTRICTED

9. The commutator, if worn or scored, may be skimmed to a diameter of not less than 0.69 in. The minimum permissible brush length is 0.1 in.

10. If the seal retaining pin is damaged it should be removed from the body with a pair of long nosed pliers, the hole cleaned and a new pin lightly tapped into position. Minor imperfections may be removed from non-critical, non-mating surfaces of the throat, cover and pump body by polishing with aluminium oxide abrasive cloth, provided that not more than 0.002 in. of material is removed from the polished surface.

Assembling

11. (1) Fit the brush plate, bearing, retaining ring and slinger on to the armature shaft. Fit the brushes into the holders from which they were removed. Fit the brush springs and secure with cotter pins.

(2) Position the armature assembly in the pump body. Turn the brush plate until the cut out section is directly above the internal passageway for the leads and secure the assembly to the pump body with four screws.

(3) Slide the retaining ring and grommet down over the leads. Thread the leads into the aperture, and through the internal passage in the pump body. Insert the grommet in the aperture and secure it with the retaining ring. Connect the white lead to the negative brush holder and the black lead to the positive brush holder.

(4) Pack the bearing bore in the cover with grease XG275. Fit the loading spring washer, insulator and new packing in the cover. Fit the bearing to the armature shaft, mount the cover on the pump body and secure in position using four screws and plain washers.

(5) Bed the brushes and test the motor as detailed in para. 12-14.

(6) After testing wire lock the motor cover retaining screws.

(7) Support the motor assembly, with the pump body uppermost, between the padded jaws of a vice. Fit new packing to the stationary seal and fit the seal on the armature shaft engaging one of the cuts around the seal shoulder with the seal retaining pin. Fit new packing in the groove of the armature shaft. Fit the rotating seal over the packing and fit the driver.

(8) Calculate the shim thickness required to give a clearance of 0.004-0.006 in. between the impeller and the counter bore of the body (fig. 4). Impeller clearances are obtained with the armature shaft end play taken up toward the impeller end. To calculate the shim thickness proceed as follows:—

(a) Determine the end play of the armature assembly.

(b) Measure the distance from the exposed face of the driver, to the horizontal face of the body counter-bore (dimension A, fig. 4). Measure the distance between the parallel flat

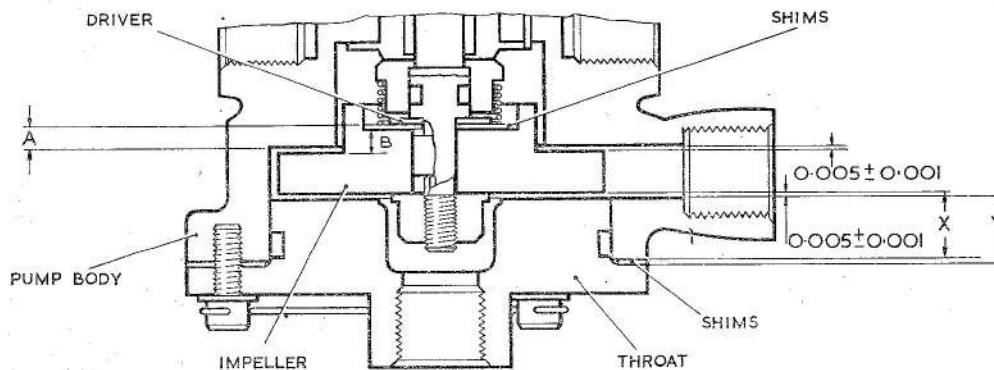

Fig. 4. Shim installation details

RESTRICTED

faces of the impeller (dimension B, fig. 4). Subtract dimension B from dimension A and add 0.005 in. to the difference.

(c) To allow for shaft end play, subtract the amount recorded in step (a) from that obtained in step (b). The result will be the shim thickness required. A shim of less than 0.002 in. should not be used.

(9) Fit the spring over the rotating seal. Fit the required thickness of shims. Fit the impeller key in the armature shaft keyway. Fit the impeller and secure with a plain washer and self locking nut.

(10) Calculate the shim thickness required to provide a clearance of 0.004-0.006 in. between the impeller and throat (fig. 4). To calculate the shim thickness required proceed as follows:—

(a) Measure the distance from the lower face of the impeller to the bottom face of the pump body (dimension X, fig. 4).

(b) Measure the depth of the throat (dimension Y, fig. 4), subtract this dimension from that obtained in (a) and add 0.005 in. to the difference.

(c) To allow for armature shaft end play, add to the result obtained in (b) the amount of shaft end play obtained in sub-para (7) (a). The result is the required shim thickness.

(11) Fit the shims to the mounting flange of the throat. Fit new packing in the throat groove. Fit the throat in the pump body and secure with washers and screws. Wire lock the three screws together.

TESTING

Motor

Brush bedding

12. Connect the motor to a d.c. power supply and run the motor on no load with the voltage adjusted to give 6,800 rev/min (approx. 15V). The motor should be run for approximately 4 hours.

Performance

13. Connect the motor to a suitable test rig and ensure that the figures detailed in table 1 are obtained.

TABLE 1
Performance test

Torque (oz in)	Speed (rev/min)	Current amps
0	10,000	1.0 max.
7	6,700	3.5 max.

Insulation resistance test

14. Remove the motor assembly cover and lift the negative brush from the earthed brush holder. Using a 250V insulation resistance tester, test between the black lead and frame; a reading of not less than 5000 ohm should be obtained.

Pump

15. Install the pump in the universal test rig 5G/3494. Connect the motor to a 27V d.c. supply and run the unit at 0.9 gal/min for approximately 10 minutes to allow the motor temperature to stabilize.

Note . . .

The test fluid temperature must not exceed 100 deg. F.

Calibration

16. Run the pump to give the output detailed in Table 2 and ensure that the current does not exceed 3A.

TABLE 2
Calibration test

Flow gal/min	Pressure lb/in ²	Current amps	Voltage volts
0	2.3	3 (max)	27
0.9	14.5	3 (max)	27

Leakage

17. During the calibration test there must be no leakage at the drain ports. After the test maintain the pump inlet pressure at 3 lb/in² for 5 min and ensure that there is no leakage at the shaft seal.

RESTRICTED

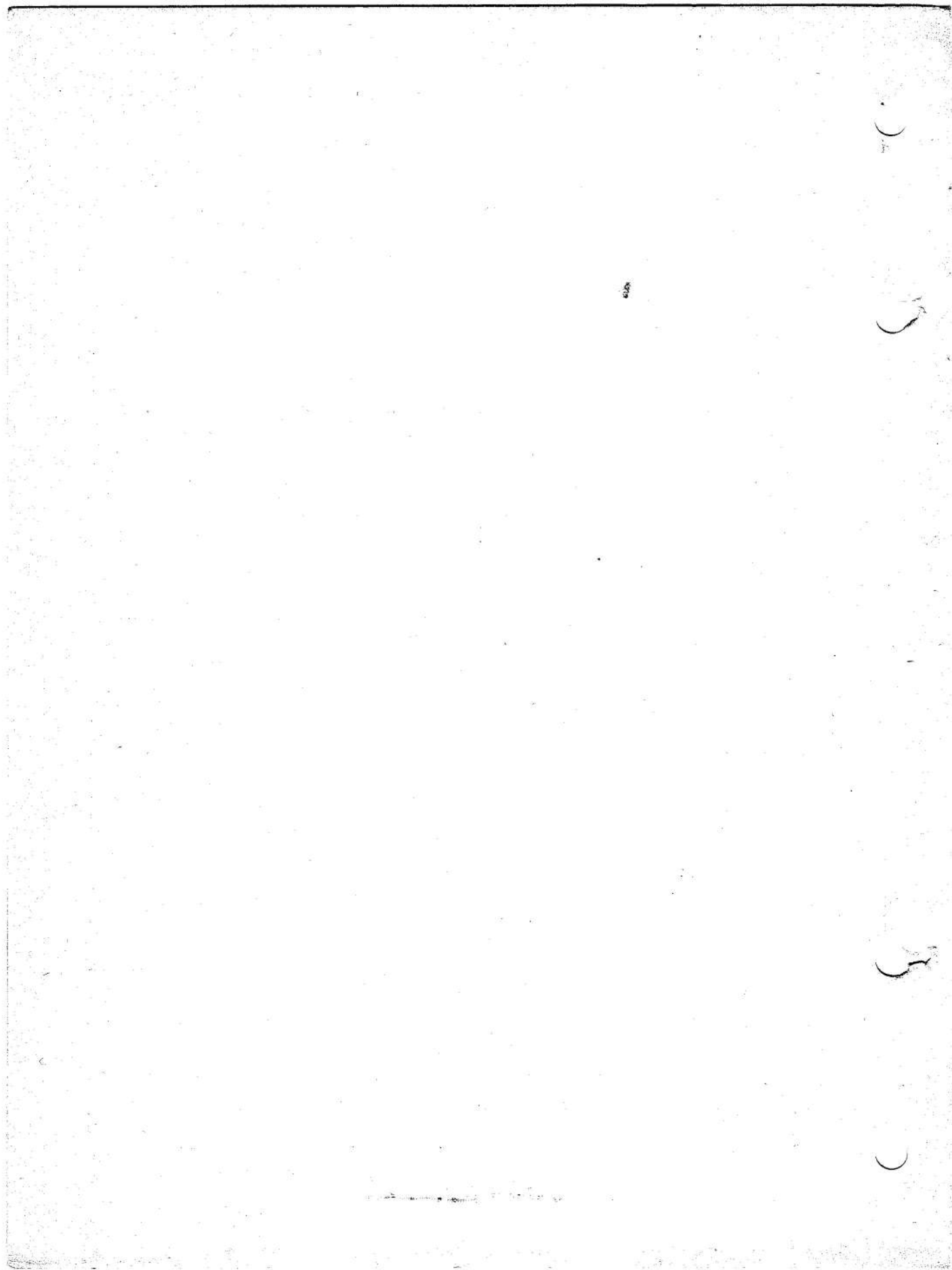

This file was downloaded
from the RTFM Library.

Link: www.scottbouch.com/rtfm

Please see site for usage terms,
and more aircraft documents.

